

202844 Evenflo[®] Automatic Pressure Control

306479E
ENG

The Evenflo[®] Automatic Pressure Control prevents initial surging when the gun is triggered, permitting the operator to maintain a perfectly even spray coating. The control admits air to the pump as the gun is triggered, and shuts off and exhausts air from the pump as the gun trigger is released. With the pump's relax-a-valve in the automatic position (see separate pump instruction manual), the exhausting air opens the relax-a-valve, permitting material to discharge through the drain back tube until pressure in the hose and pump is relieved.

175 psi (12 bar) Maximum Working Pressure



Important Safety Instructions

Read all warnings and instructions in this manual.
Save these instructions.

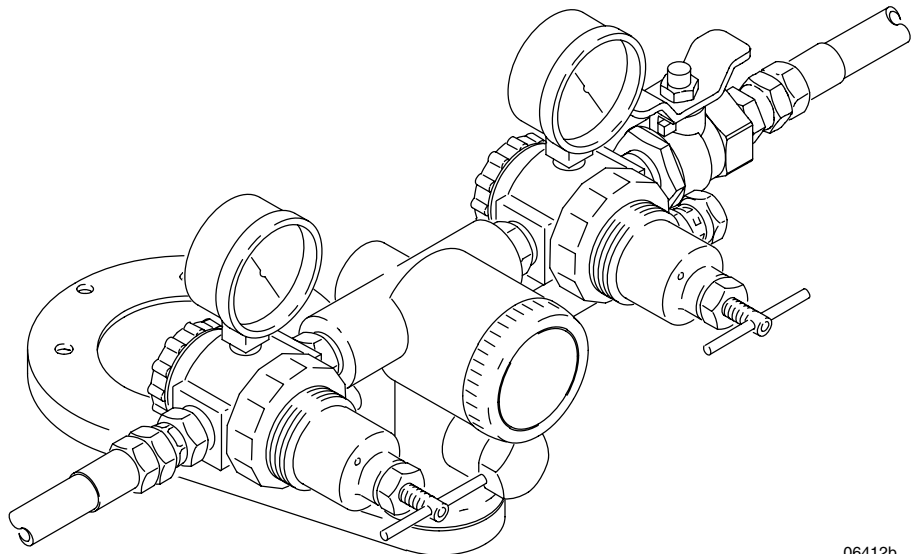

06412b

Table of Contents

Warnings	2	Parts List	7
Operation	4	Graco Warranty	8
Service	6	Graco Information	8
Parts Drawing	7		

Symbols

Warning Symbol





This symbol alerts you to the possibility of serious injury or death if you do not follow the instructions.

Caution Symbol



This symbol alerts you to the possibility of damage to or destruction of equipment if you do not follow the instructions.

 WARNING	
 INSTRUCTIONS	<p>EQUIPMENT MISUSE HAZARD</p> <p>Equipment misuse can cause the equipment to rupture or malfunction and result in serious injury.</p> <ul style="list-style-type: none"> • This equipment is for professional use only. • Read all instruction manuals, tags, and labels before operating the equipment. • Use the equipment only for its intended purpose. If you are not sure, call your Graco distributor. • Do not alter or modify this equipment. • Check equipment daily. Repair or replace worn or damaged parts immediately. • Handle hoses carefully. Do not pull on hoses to move equipment. • Route hoses away from traffic areas, sharp edges, moving parts, and hot surfaces. Do not expose Graco hoses to temperatures above 66°C (150°F) or below -40°C (-40°F). • Comply with all applicable local, state, and national fire, electrical, and safety regulations.
	<p>PRESSURIZED EQUIPMENT HAZARD</p> <p>Spray from the gun, hose leaks, or ruptured components can splash fluid in the eyes or on the skin and cause serious injury.</p> <ul style="list-style-type: none"> • Do not stop or deflect leaks with your hand, body, glove or rag. • Tighten all fluid connections before operating the equipment • Check the hoses, tubes, and couplings daily. Replace worn, damaged, or loose parts immediately.

Installation

Note: Numbers and letters in parenthesis in the text refer to callouts in Fig. 1 and the parts drawing.

1. Mount the Evenflo® Control. (See Fig. 1.)
 - a. To mount the Evenflo® Control to the pump, use screws (28) to attach the mounting plate (38) to the pump base. Remove the screw (31) and lockwasher (32) from the control (1), and position the control over the small hole of the plate. Secure the control to the plate with the screw and lockwasher.
 - b. To mount the Evenflo® Control directly to a covered drum, remove the screw (31) and lockwasher (32) from the control (1), and mount it directly to the cover
2. Connect the ball valve (26) and the air supply hose (24) to the right hand regulator (A). Connect the other end of the hose to the pump's air inlet.
3. Connect an air supply hose to the 1/2 npt(f) air inlet fitting (35).
4. Connect an air atomizing hose (C) between the 3/8 npt(f) swivel union of the left hand regulator (B) and your spray gun.

Operation

Since this control will function only as part of the complete spray outfit, the operation of the Evenflo® valve is explained in the instruction manual for the complete spray outfits

Note: When spraying light fluids, the ball valve (26), may be used to regulate the pump speed. Adjust the right hand air regulator (A) to a higher pressure than necessary to operate the pump and regulate the speed of the pump by the operation of the ball valve handle. The ball valve also provides a quick shutoff to the air pump.

By-pass Valve Adjustment

1. With the air supplied to the pump and the spray gun, and the pump relax-a-valve set in the automatic position, open the by-pass valve (2) four full turns from the closed position. See Fig. 1.
2. Point the spray gun into the drum and trigger the gun. If the pump does not operate, release the trigger and close the by-pass valve 1/4 turn.
3. Repeat this process until the pump operates when the gun is triggered.

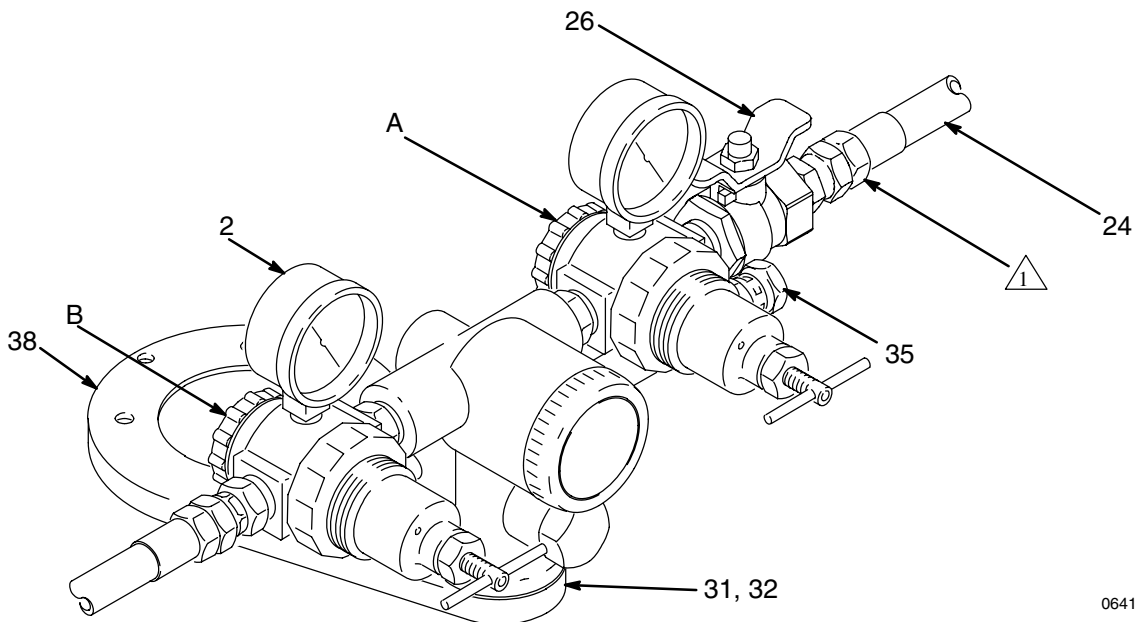

Fig. 1

06412b

Troubleshooting

Note: Check all possible solutions before disassembling the control.

Problem	Probable Cause	Remedy
The Evenflo® delivers an insufficient air to the pump when the spray gun is open.	The air supply is insufficient.	Check the hose for obstructions or leaks. Open the master air valve. Remove, clean and oil the filter screen.
	The right-hand regulator is set too low.	Loosen the locknut and turn the regulator T-handle clockwise to increase pressure.
	The right-hand regulator is inoperative.	See manual 308167 for air regulator service.
	The by-pass valve is open too far.	Adjust, as explained on page 4.
	The left-hand air regulator is set too low.	Loosen the locknut, and turn the regulator T-handle counterclockwise to decrease pressure.
	The left-hand regulator is inoperative.	See manual 308167 for air regulator service.
	The atomizing air hose is clogged.	Clear.
	The ball valve is set too lean.	Open.
	The air hose to the pump is clogged.	Clear.
	The Evenflo® valve is inoperative.	Oil the filter screen and service.
Air escapes continuously through the exhaust port while the gun is open.	The valve seal, seat, stem, or spring is broken or worn.	Replace.
The unloading action is sluggish.	The small hole in the piston (19) is clogged.	Service.
	The piston or o-ring (9) is seized.	Service.
	The by-pass valve is turned too far inward.	Adjust.
The air pressure drops excessively when the gun is triggered.	The filter screen is clogged.	Remove, clean, and oil the filter screen.
	The main air pressure is too low.	Check air supply.
	The by-pass valve is closed too far.	Adjust.

Service

Daily Maintenance

Relieve the air pressure to the Evenflo[®], and shut off the main valve. Each day, clean the filter screen (10) and add light oil to the filter cavity in the housing (13). See the parts drawing on page 7.

Evenflo[®] Valve Service

1. Unscrew the cap (20) from the housing (13) and remove the spring (12). Place a screwdriver in the slot of the stem (14) and unscrew the nut (3) from the opposite end. See the parts drawing on page 7.
2. Grip the flats on the nose of the piston (19) with pliers and pull the piston out from the housing, freeing the seal (23).
3. Disassemble the valve; clean the valve thoroughly in a non-flammable solvent, and blow-dry the valve. Inspect all parts for wear or damage. Inspect the rubber seat (15). Do not remove the seat (unless replacement is necessary. If the seat must be replaced, tuck the new seat into the housing with a smooth blunt instrument, being careful not to damage it. Pay special attention to the housing at points of contact with the piston seal (9), the valve seal (23), the plunger valve (16), and the stem (14).
4. Lubricate the inner parts and surfaces with light oil, and reassemble the valve in reverse order of disassembly.

Parts

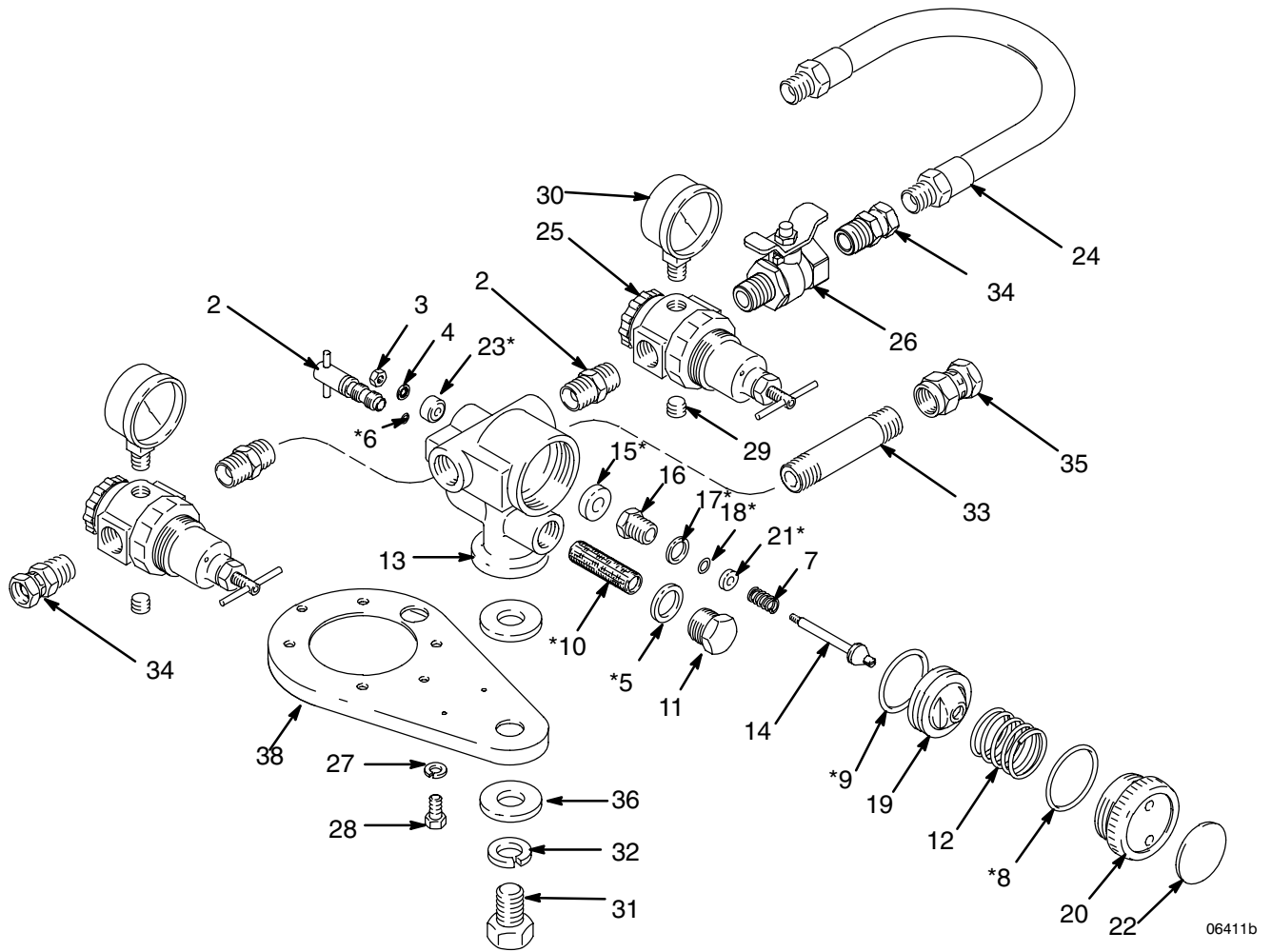

Parts List

Ref. No.	Part No.	Description	Qty.	Ref. No.	Part No.	Description	Qty.
1	202843	EVENFLO VALVE® includes items 2-23	1	24	214652	HOSE, air; cpld 3/8 npt(m); 1/2" ID; 18" (457 mm) long	1
2	202864	. STEM, by-pass valve	1	25	104266	AIR REGULATOR (See manual 308167 for parts)	2
3	100072	. NUT, hex; no. 6-32	1	26	107142	BALL VALVE	1
4	100272	. LOCKWASHER, int. shkprf; no. 6	1	27	100016	LOCKWASHER, 1/4	4
5*	150647	. GASKET, copper	1	28	100333	SCREW, hex hd cap; 1/4-20 x 12	4
6*	154741	. O-RING, nitrile rubber	1	29	100721	PLUG, pipe; 1/4" slotted	2
7	156200	. SPRING, compression	1	30	100960	GAUGE, air pressure; 0-200 psi (0-14 bar) range	2
8*	156594	. O-RING, nitrile rubber	1	31	100995	SCREW, hex hd cap; 3/4-16 x 1"	1
9*	156633	. O-RING, nitrile rubber	1	32	101015	LOCKWASHER, spring; 3/4"	1
10*	156939	. STRAINER, 100 mesh	1	33	101353	NIPPLE, pipe; 1/2 npt; 4" (102 mm) long	1
11	156944	. NUT, strainer	1	34	158256	UNION, adapter, 3/8 npt(m) x 3/8 npsm(f) swivel	2
12*	157633	. SPRING, compression	1	35	155865	UNION, female adapter; 1/2 npt(f)	1
13	158331	. HOUSING	1	36	156306	WASHER	2
14	158482	. STEM	1	37	158491	NIPPLE	2
15*	158483	. SEAT, plunger valve	1	38	159058	PLATE, mounting	1
16	158484	. VALVE, plunger	1				
17*	158485	. GASKET, copper	1				
18*	158486	. O-RING, nitrile rubber	1				
19	158487	. PISTON	1				
20	158488	. CAP	1				
21*	158489	. WASHER	1				
22	158580	. PLATE, instruction	1				
23*	159340	. SEAL, valve	1				

* Recommended tool box spare parts. Keep these spare parts on hand to reduce down time

Graco Standard Warranty

Graco warrants all equipment manufactured by Graco and bearing its name to be free from defects in material and workmanship on the date of sale by an authorized Graco distributor to the original purchaser for use. With the exception of any special, extended, or limited warranty published by Graco, Graco will, for a period of twelve months from the date of sale, repair or replace any part of the equipment determined by Graco to be defective. This warranty applies only when the equipment is installed, operated and maintained in accordance with Graco's written recommendations.

This warranty does not cover, and Graco shall not be liable for general wear and tear, or any malfunction, damage or wear caused by faulty installation, misapplication, abrasion, corrosion, inadequate or improper maintenance, negligence, accident, tampering, or substitution of non-Graco component parts. Nor shall Graco be liable for malfunction, damage or wear caused by the incompatibility of Graco equipment with structures, accessories, equipment or materials not supplied by Graco, or the improper design, manufacture, installation, operation or maintenance of structures, accessories, equipment or materials not supplied by Graco.

This warranty is conditioned upon the prepaid return of the equipment claimed to be defective to an authorized Graco distributor for verification of the claimed defect. If the claimed defect is verified, Graco will repair or replace free of charge any defective parts. The equipment will be returned to the original purchaser transportation prepaid. If inspection of the equipment does not disclose any defect in material or workmanship, repairs will be made at a reasonable charge, which charges may include the costs of parts, labor, and transportation.

THIS WARRANTY IS EXCLUSIVE, AND IS IN LIEU OF ANY OTHER WARRANTIES, EXPRESS OR IMPLIED, INCLUDING BUT NOT LIMITED TO WARRANTY OF MERCHANTABILITY OR WARRANTY OF FITNESS FOR A PARTICULAR PURPOSE.

Graco's sole obligation and buyer's sole remedy for any breach of warranty shall be as set forth above. The buyer agrees that no other remedy (including, but not limited to, incidental or consequential damages for lost profits, lost sales, injury to person or property, or any other incidental or consequential loss) shall be available. Any action for breach of warranty must be brought within two (2) years of the date of sale.

Graco makes no warranty, and disclaims all implied warranties of merchantability and fitness for a particular purpose in connection with accessories, equipment, materials or components sold but not manufactured by Graco. These items sold, but not manufactured by Graco (such as electric motors, switches, hose, etc.), are subject to the warranty, if any, of their manufacturer. Graco will provide purchaser with reasonable assistance in making any claim for breach of these warranties.

In no event will Graco be liable for indirect, incidental, special or consequential damages resulting from Graco supplying equipment hereunder, or the furnishing, performance, or use of any products or other goods sold hereto, whether due to a breach of contract, breach of warranty, the negligence of Graco, or otherwise.

FOR GRACO CANADA CUSTOMERS

The parties acknowledge that they have required that the present document, as well as all documents, notices and legal proceedings entered into, given or instituted pursuant hereto or relating directly or indirectly hereto, be drawn up in English. Les parties reconnaissent avoir convenu que la rédaction du présente document sera en Anglais, ainsi que tous documents, avis et procédures judiciaires exécutés, donnés ou intentés à la suite de ou en rapport, directement ou indirectement, avec les procédures concernées.

Graco Information

For the latest information about Graco products, visit www.graco.com.

TO PLACE AN ORDER, contact your Graco distributor or call to identify the distributor closest to you:

Phone: 612-623-6921 or **Toll Free:** 1-800-328-0211 **Fax:** 612-378-3505

*All written and visual data contained in this document reflects the latest product information available at the time of publication.
Graco reserves the right to make changes at any time without notice.*

Original instructions. This manual contains English. MM 306479

Graco Headquarters: Minneapolis

International Offices: Belgium, China, Japan, Korea

GRACO INC. P.O. BOX 1441 MINNEAPOLIS, MN 55440-1441

Copyright 1996, Graco Inc. is registered to ISO 9001

www.graco.com

Revised 05/2011