

Instructions-Parts List



19 liter (5 gallon)
120 liter (30 gallon)
200 liter (55 gallon)

Ram-Mounted Pumps

308027ZAD
EN

Use to transfer or dispense sealants, adhesives, or other medium- to high-viscosity fluids. For professional use only. Not approved for use in European explosive atmosphere locations.



Important Safety Instructions

Read all warnings and instructions in this manual.
Save these instructions.

Table of Contents

Warnings	2
List of Models	4
Setup	5
Installation	13
Operation	16
PLC Interface Service	23
Parts	26
Dimensions	63
Technical Data	64
Graco Standard Warranty	66
Graco Information	66

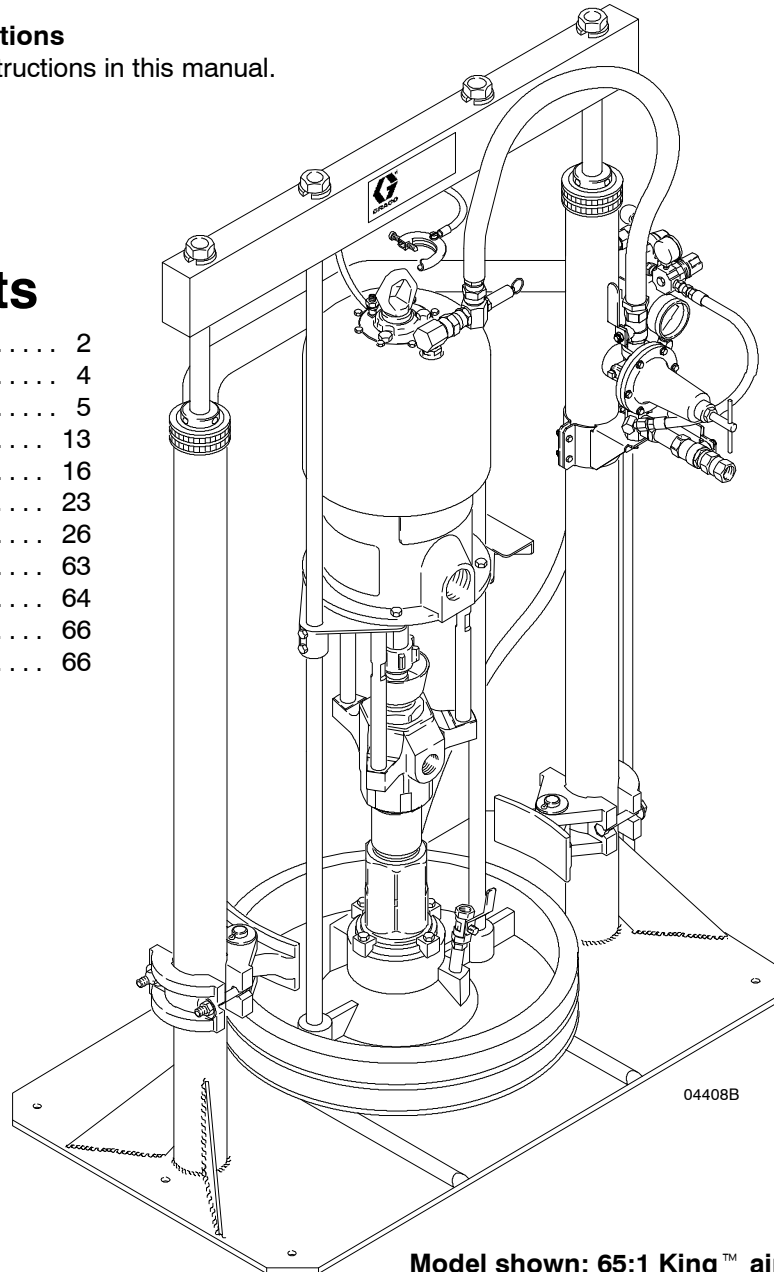

Model shown: 65:1 King™ air motor with
Check-Mate™ 800 pump lower

Symbols

Warning Symbol



This symbol alerts you to the possibility of serious injury or death if you do not follow the instructions.

Caution Symbol



This symbol alerts you to the possibility of damage to or destruction of equipment if you do not follow the instructions.

WARNING



INSTRUCTIONS

EQUIPMENT MISUSE HAZARD

Equipment misuse can cause the equipment to rupture or malfunction and result in serious injury.

- This equipment is for professional use only.
- Read all instruction manuals, tags, and labels before you operate the equipment.
- Use the equipment only for its intended purpose. If you are not sure, call your Graco distributor.
- Do not alter or modify this equipment. Use only Graco parts and accessories.
- Check equipment daily. Repair or replace worn or damaged parts immediately.
- Do not exceed the maximum working pressure stated on the equipment or in the **Technical Data** for your equipment. Do not exceed the maximum working pressure of the lowest rated component in your system.
- Use fluids and solvents that are compatible with the equipment wetted parts. See the **Technical Data** section of all equipment manuals. Read the fluid and solvent manufacturer's warnings.
- Wear hearing protection when you operate this equipment.
- Comply with all applicable local, state, and national fire, electrical, and safety regulations.



MOVING PARTS HAZARD

Moving parts, such as the priming piston and ram plate, can pinch or amputate your fingers.

- Keep clear of all moving parts when you start or operate the pump.
- Keep hands and fingers away from the priming piston during operation and whenever the pump is charged with air.
- Keep your hands away from the ram plate and the lip of the drum while the ram is operating.
- Before you service the equipment, follow the **Pressure Relief Procedure** on page 16 to prevent the equipment from starting unexpectedly.



TOXIC FLUID HAZARD

Hazardous fluid or toxic fumes can cause serious injury or death if splashed in the eyes or on the skin, inhaled, or swallowed.

- Know the specific hazards of the fluid you are using.
- Store hazardous fluid in an approved container. Dispose of hazardous fluid according to all local, state, and national guidelines.
- Always wear protective eyewear, gloves, clothing, and respirator as recommended by the fluid and solvent manufacturer.

! WARNING



SKIN INJECTION HAZARD

Spray from the spray gun/dispense valve, leaks, or ruptured components can inject fluid into your body and cause extremely serious injury, including the need for amputation. Fluid splashed in the eyes or on the skin can also cause serious injury.

- Fluid injected into the skin might look like just a cut, but it is a serious injury. **Get immediate surgical treatment.**
- Do not point the gun/valve at anyone or at any part of the body.
- Do not put your hand or fingers over the spray tip/nozzle.
- Do not stop or deflect leaks with your hand, body, glove or rag.
- Do not “blow back” fluid; this is not an air spray system.
- Always have the tip guard and the trigger guard on the gun when spraying.
- Check the gun diffuser operation weekly. See the gun manual.
- Be sure the gun/valve trigger safety operates before you spray/dispense.
- Lock the gun/valve trigger safety when you stop spraying/dispensing.
- Follow the **Pressure Relief Procedure** on page 16 if the spray tip/nozzle clogs and before you clean, check, or service the equipment.
- Tighten all fluid connections before you operate the equipment.
- Check the hoses, tubes, and couplings daily. Replace worn or damaged parts immediately. Do not repair high pressure couplings; you must replace the entire hose.
- Fluid hoses must have spring guards on both ends to help protect them from rupture caused by kinks or bends near the couplings.



FIRE AND EXPLOSION HAZARD

Improper grounding, poor ventilation, open flames, or sparks can cause a hazardous condition and result in a fire or explosion and serious injury.

- Ground the equipment and the object being sprayed or dispensed to. See **Ground the System** on page 5.
- If there is any static sparking or you feel an electric shock while using this equipment, **stop spraying/dispensing immediately.** Do not use the equipment until you identify and correct the problem.
- Provide fresh air ventilation to avoid the buildup of flammable fumes from solvents or the fluid being sprayed/dispensed to.
- Keep the spray/dispense area free of debris, including solvent, rags, and gasoline.
- Electrically disconnect all equipment in the spray/dispense area.
- Extinguish all open flames or pilot lights in the spray/dispense area.
- Do not smoke in the spray/dispense area.
- Do not turn on or off any light switch in the spray/dispense area while operating or if fumes are present.
- Do not operate a gasoline engine in the spray/dispense area.

List of Models

55 Gallon Models

Model No. (Parts page)	Air Motor	Pump Lower	Ratio	Maximum Fluid Working Pressure	Maximum Input Pressure
223816 (26)	Monark®	Check-Mate™ 450	10:1	125 bar, 12.5 MPa (1800 psi)	10 bar, 1 MPa (150 psi) (Air)
223817* (28)	President®	Check-Mate™ 450	20:1	250 bar, 25.0 MPa (3600 psi)	10 bar, 1 MPa (150 psi) (Air)
253018* (28)	President®	Check-Mate™ 450	20:1	250 bar, 25.0 MPa (3600 psi)	10 bar, 1 MPa (150 psi) (Air)
234369* (28)	President®	Check-Mate™ 450 Tuffstack	20:1	250 bar, 25.0 MPa (3600 psi)	10 bar, 1 MPa (150 psi) (Air)
234120* (30)	President®	Check-Mate™ 450	46:1	320 bar, 32.0 MPa (4600 psi)	7 bar, 0.7 MPa (100 psi) (Air)
247156* (30)	President®	Check-Mate™ 450	46:1	320 bar, 32.0 MPa (4600 psi)	7 bar, 0.7 MPa (100 psi) (Air)
234121* (30)	Monark®	Check-Mate™ 200	23:1	290 bar, 29.0 MPa (4140 psi)	12 bar, 1.2 MPa (180 psi) (Air)
247155* (30)	Monark®	Check-Mate™ 200	23:1	290 bar, 29.0 MPa (4140 psi)	12 bar, 1.2 MPa (180 psi) (Air)
257589* (30)	FireBall 425 Pump		50:1	276 bar, 28 MPa (4000 psi)	5.5 bar, 0.55 MPa (80 psi) (Air)
570114 (32)	NXT 700	Check-Mate™ 450	20:1	138 bar, 13 MPa (2000 psi)	7 bar, 0.7 MPa (100 psi) (Air)
965572 (34)	NXT 2200	Check-Mate™ 450	40:1	276 bar, 28 MPa (4000 psi)	7 bar, 0.7 MPa (100 psi) (Air)
234371* (36)	Bulldog®	Check-Mate™ 2100	12:1	83 bar, 8.3 MPa (1200 psi)	7 bar, 0.7 MPa (100 psi) (Air)
234376* (38)	Viscount II®	Check-Mate™ 2100	1.6:1	165 bar, 16.5 MPa (2400 psi)	104 bar, 10.4 MPa (1500 psi) (Hydraulic)
234372 (40)	King™	Check-Mate™ 2100	24:1	165 bar, 16.5 MPa (2400 psi)	7 bar, 0.7 MPa (100 psi) (Air)
234373 (40)	King™	Check-Mate™ 800 Ink	65:1	448 bar, 44.8 MPa (6500 psi)	7 bar, 0.7 MPa (100 psi) (Hydraulic)
234374* (44)	Bulldog™	Check-Mate™ 800	31:1	214 bar, 21.4 MPa (3100 psi)	7 bar, 0.7 MPa (100 psi) (Hydraulic)
253482 (46)	Bulldog™	Dura-Flo 600	41:1	138 bar, 13 MPa (2000 psi)	7 bar, 0.7 MPa (100 psi) (Air)
234377* (54)	Senator®	Check-Mate™ 800	19:1	132 bar, 13.2 MPa (1900 psi)	7 bar, 0.7 MPa (100 psi) (Hydraulic)
234378* (56)	Viscount II®	Check-Mate™ 800	4.33:1	448 bar, 44.8 MPa (6500 psi)	104 bar, 10.4 MPa (1500 psi) (Hydraulic)



NOTE: Ram Mounting Kit 224829 is available to mount a Check-Mate™ 200 Pump on a 200-liter (55 gal.) Ram. See pages 58 to 61.

Setup

Ground the System

⚠ WARNING

FIRE AND EXPLOSION HAZARD
Improper grounding could cause static sparking, which could cause a fire or explosion. To reduce the risk of property damage or serious injury, follow the grounding instructions below.

The following grounding instructions are minimum requirements for a system. Your system may include other equipment or objects that must be grounded. Check your local electrical code for detailed grounding instructions for your area and type of equipment. Your system must be connected to a true earth ground.

- **Pump:** Check the ground wire and clamp. See Fig. 1. To install, loosen the grounding lug locknut (W) and washer (X). Insert one end of a 1.5 mm² (12 ga) minimum ground wire (Y) into the slot in the lug (Z), and tighten the locknut securely. Connect the other end of the wire to a true earth ground.

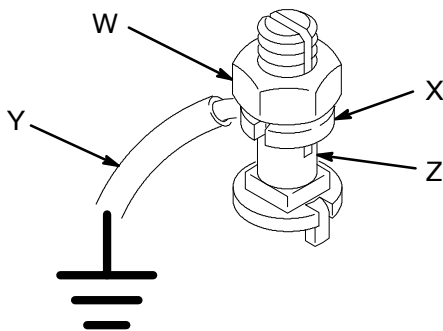

0864

Fig. 1

- **Air compressors and hydraulic power supplies:** Follow the manufacturer's grounding recommendations.
- **Air, fluid, and hydraulic hoses connected to the pump:** Use only electrically conductive hoses with a maximum of 150 m (500 ft) combined hose length to ensure grounding continuity. Check the electrical resistance of air and fluid hoses at least once a week. If the total resistance to ground exceeds 29 megohms, replace the hose immediately.
NOTE: Use a meter that is capable of measuring resistance at this level.
- **Spray gun / dispense valve:** Connect to a properly grounded fluid hose and pump.
- **Fluid supply container:** Follow the local code for grounding.
- **Object being sprayed / dispensed to:** Follow the local code for grounding.
- **All solvent pails used when flushing:** Follow the local code for grounding. Use only metal pails, which are conductive. Do not place the pail on a non-conductive surface, such as paper or cardboard, which interrupts the grounding continuity.

To maintain grounding continuity when flushing or relieving pressure, always hold a metal part of the gun/dispense valve firmly to the side of a grounded metal pail, then trigger the gun/dispense valve.

Typical Setup

KEY

- | | |
|--|--|
| A Pump | P Electrically conductive fluid whip hose |
| B Ram | R Gun/valve swivel |
| C Ram plate | S Gun or dispense valve |
| D Electrically conductive air supply hose | T Ram air regulator |
| E Main air bleed valve (required, for pump and ram) | U Ram director valve |
| F Air manifold | V Air release valve |
| G Pump air regulator | W Air line drain valve |
| H Pump air bleed valve (required, for pump) | Y Ground wire (required) |
| J Air line filter | <i>See page 5 for installation instructions.</i> |
| K Bleed-type air valve (for accessories) | AA Safety valve |
| L Fluid drain valve (required) | CC Vent valve |
| M Fluid pressure regulator | DD Pump Runaway Valve (location shown) |
| N Electrically conductive fluid hose | |

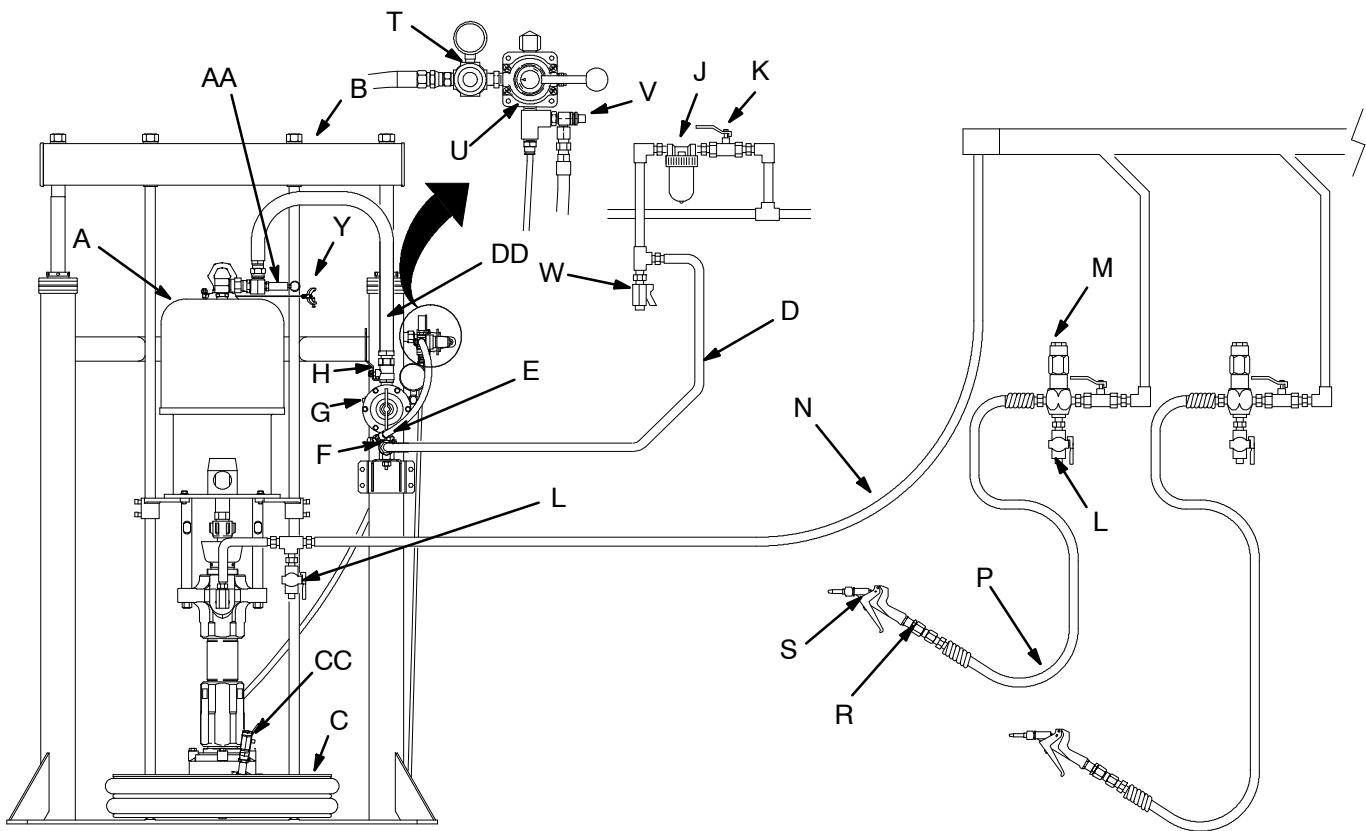

5097B

Fig. 2

Setup

NOTE: Numbers and letters in parentheses in the text refer to the callouts in the figures and the Parts Drawings.

Accessories are available from Graco. Make certain all accessories are sized and pressure-rated to meet your system requirements.

Fig. 2 is only a guide for selecting and installing system components and accessories. Contact your Graco distributor for assistance in designing a system to suit your particular needs.

Air Line Components and Accessories

See Fig. 2.

WARNING

A main air bleed valve (E), pump air bleed valve (H), and fluid drain valve (L) are required. These accessories help reduce the risk of serious injury, including fluid injection and splashing of fluid in the eyes or on the skin, and injury from moving parts if you are adjusting or repairing the pump.

The main air bleed valve (E) shuts off and relieves the air to the pump and ram. The ram holds pressure if the ram director valve (U) is in the horizontal (neutral) position. To relieve air pressure in the ram, close the main air bleed valve (E), and move the director valve (U) to DOWN. The ram will slowly drop.

The pump air bleed valve (H) relieves air trapped between it and the pump after the air is shut off. Trapped air can cause the pump to cycle unexpectedly. Install the valve close to the pump.

The fluid drain valve assists in relieving fluid pressure in the displacement pump, hose, and gun. Triggering the gun might not be sufficient for relieving pressure.

- **Main air bleed valve (E)**
Required in your system to shut off the air supply to the pump and ram (see **WARNING** at left). When closed, the valve bleeds off all air in the ram and pump, and the ram slowly lowers. Be sure the valve is easily accessible from the pump and is installed **upstream** from the air manifold (F).
- **Pump air bleed valve (H)**
Required in your system to relieve air trapped between it and the air motor when the valve is closed (see **WARNING** at left). Be sure the valve is easily accessible from the pump, and is installed **downstream** from the air regulator (G).
- **Air regulator (G)**
Controls pump speed and outlet pressure by adjusting the air pressure to the pump. Install the regulator close to the pump, but **upstream** from the pump air bleed valve.
- **Air manifold (F)**
Has a swivel air inlet. Mounts to the cart and provides ports for connecting lines to air-powered accessories.
- **Air line filter (J)**
Removes harmful dirt and moisture from the compressed air supply.
- **Second bleed-type air valve (K)**
Isolates air line accessories for servicing. Install upstream from all other air line accessories.
- **Ram air regulator (T)**
Controls air pressure to the ram.
- **Ram director valve (U)**
Controls raising and lowering of the ram.
- **Air release valve (V)**
Opens and closes flow of air to assist raising the ram plate (C) out of an empty drum.
- **Vent valve (CC)**
Bleeds air from under the ram plate (C) to assist in priming the pump and lowering the ram plate into the drum.

Setup

Some pumps require assembly. To install the pump and other components on the ram, follow the instructions at right for **Senator and Bulldog Pumps** or on page 10 for **President and Monark Pumps**. To mount a Check-Mate 200 Pump on a ram, install the 224829 Mounting Kit (see pages 58 to 61).

Location

Position the ram so the air regulators for the pump and the ram are easily accessible. Ensure that there is sufficient overhead clearance when the ram is fully raised. See the Dimensional Drawing in the separate ram manual 306934, supplied.

Using the holes in the ram base as a guide, drill holes for 1/2 in. (13 mm) anchors.

Check that the ram base is level in all directions. If necessary, level the base using metal shims. Secure the base to the floor using 13 mm (1/2 in.) anchors that are long enough to prevent the ram from tipping.

Air and Fluid Hoses

Be sure all air hoses (D) and fluid hoses (N, P) are properly sized and pressure-rated for your system. Use only electrically conductive hoses. Fluid hoses must have spring guards on both ends. Use of a short whip hose (P) and a swivel (R) between the main fluid hose (N) and the gun/valve (S) allows freer gun/valve movement.

Fluid Line Accessories

Install the following accessories in the locations shown in Fig. 2, using adapters as necessary:

- **Fluid drain valve (L)**
Required in your system to relieve fluid pressure in the hose and gun/valve (see **WARNING** on page 7). Screw the drain valve into the open branch of a tee mounted in the fluid line. Install the drain valve pointing down, but so the handle points up when opened.
- **Fluid regulator (M)**
Controls fluid pressure to the gun/valve and dampens pressure surges.
- **Gun or dispense valve (S)**
Dispenses the fluid. The gun shown in Fig. 2 is a dispensing gun for highly viscous fluids.
- **Gun swivel (R)**
Allows freer gun/valve movement.

Assembly Procedure

Senator and Bulldog Pumps

1. Install the gasket or o-ring (6) from Mounting Kit 222776 on the ram plate (P). See Fig. 3.
2. Lower the pump (2) onto the ram plate (P), and secure it with the four lugs (5) and screws (4). Secure the pump to the mounting plates (Q) with the screws and washers (R) included with the ram.
3. Install the drum clamps (17) on the cylinders of the ram (1) to hold the drum steady (55 gal. drum models).
4. Install the air regulation kit (7): Insert the air manifold stud in the hole on the ram mounting bracket (S), and secure it with washers and nut (T). Connect the air regulation kit hose (U) to the pump air inlet.
5. **Check-Mate 450 and 200 Pumps:** Screw the bushing (24) into the elbow (21), and screw the elbow onto the pump outlet fitting so the bushing faces straight up.
Check-Mate 2100 Pumps: Screw the swivel end of the outlet adapter (25) onto the pump outlet fitting so the rigid end of the adapter faces straight up.
6. Connect one end of the air hose (20) to the 1/4 npt(f) port of the air manifold. Connect the other end to the swivel adapter (BB) to the ram air regulator (see Fig. 3).

Setup

- △1 For Check-Mate 450 or 200 only
- △2 For Check-Mate 2100 only
- △3 For Check-Mate 450 or 200, use Gasket 184086.
For Check-Mate 2100, use O-ring 109495.

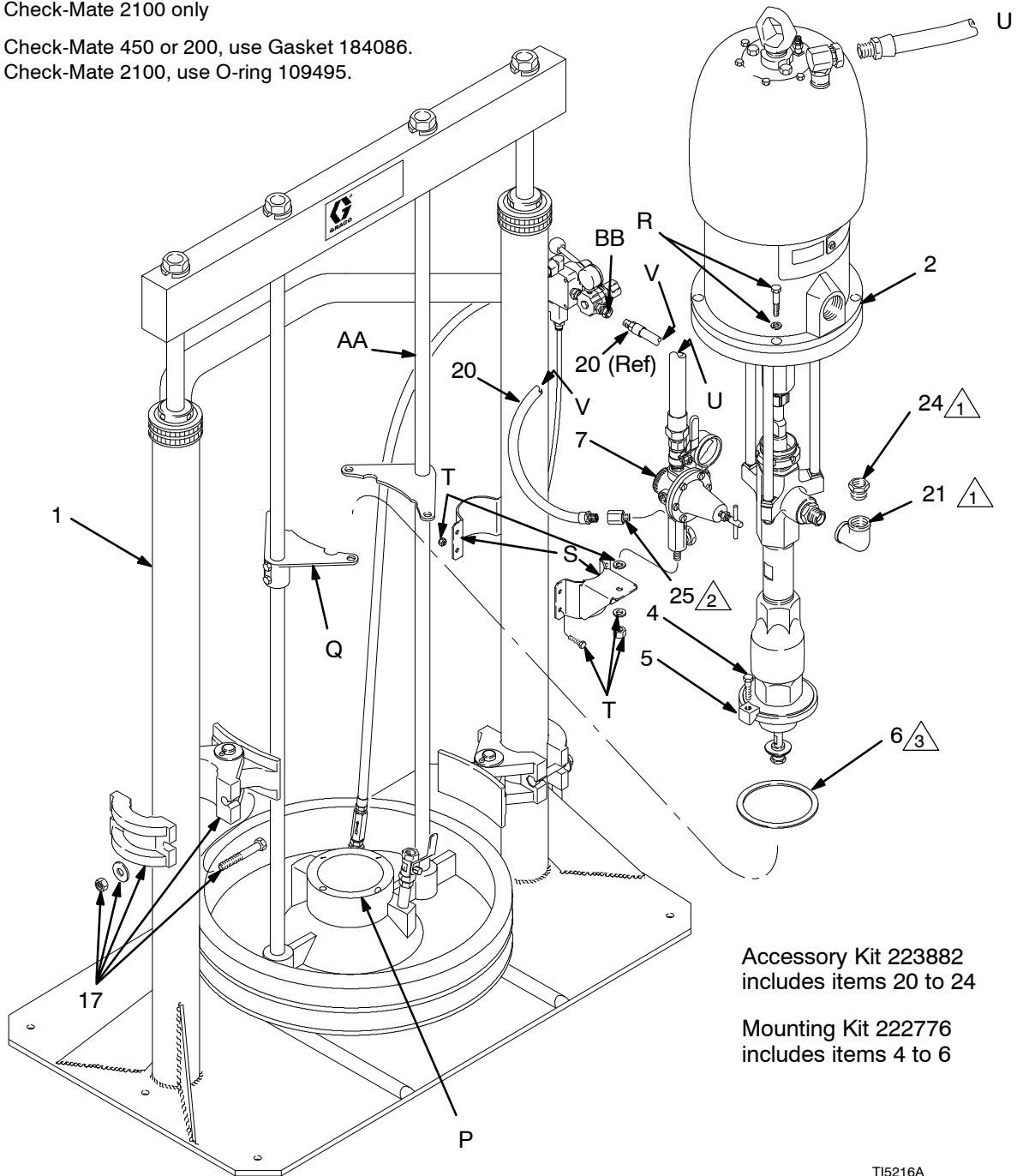

TI5216A

Fig. 3

Setup

President and Monark Pumps

1. Install the gasket (6) from Mounting Kit 222776 on the ram plate (P). See Fig. 4.
2. Install the pump mounting plate (32) onto the ram plates (Q) with the hardware included in Mounting Kit 224829.

NOTE: Fig. 4 shows the plate (32) being installed for a President pump. The mounting plate is positioned differently for a Monark pump. See the correct position in the **Parts Drawing** on page 26.

3. Lower the pump (2) onto the ram plate (P), and secure it with the four lugs (5) and screws (4). Secure the pump to the mounting plate (32) with the supplied hardware.
4. Install the drum clamps (17) on the cylinders of the ram (1) to hold the drum steady.
5. Screw the air inlet adapter (22) from the Accessory Kit 223881 into the pump air inlet. Use 3/8 npt(m) adapter 162505 for Monark pumps. Use 1/2 npt(m) nipple 100122 for President pumps.
6. Install the air regulation kit (7): Connect the non-swivel end of the 90° union (13) to the nipple (22) at the pump air inlet.
7. For Monark pumps, screw the bushing (24) into the elbow (21), then screw the elbow onto the pump outlet fitting so the bushing faces straight up. See the correct position in the **Parts Drawing** on page 26.
8. For Monark pumps, screw the 1/8 npt(m) end of adapter (23) into a 1/8 npt(f) port of the air manifold (8).
9. For President pumps, screw the 1/4 npt male end of 90° swivel union (44) into a 1/4 npt(f) port of the air manifold (8).
10. Connect one end of the air hose (20) to the swivel adapter (23 for Monark) or 90° swivel union (44 for President) at the air manifold (8). Connect the other end to the swivel adapter (BB) to the ram air regulator.

Setup

- 1 Use Gasket 184086 with these pumps.
- 2 The mounting plate (32) is shown being installed for a President pump. The plate is positioned differently for a Monark pump; See the **Parts Drawing** on page 26 for the correct position.

Model 223817 shown

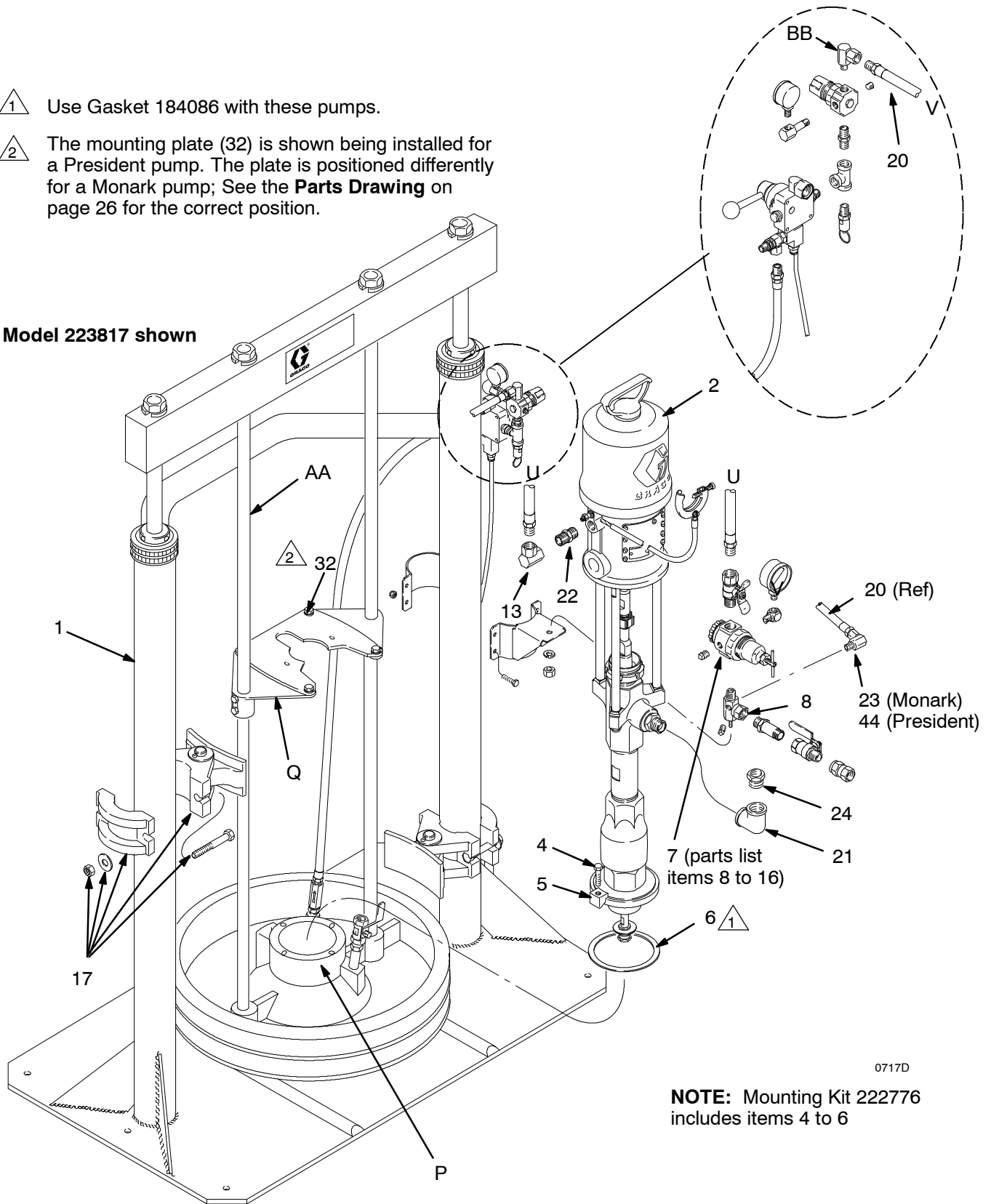

Fig. 4

0717D

NOTE: Mounting Kit 222776 includes items 4 to 6

Installation

Connecting Power to the PLC Interface

Perform the following procedure to connect the power to the junction box panel.

 **WARNING**



ELECTRIC SHOCK HAZARD
Do not connect the junction box panel to a power source unless you are a trained electrician. Failure to follow standard procedures or to observe the necessary precautions could result in serious bodily injury or equipment damage.

 **CAUTION**

If power and grounding connections are not done properly, the equipment may be damaged and the warranty will be voided.

NOTE: Have a qualified electrician connect the junction box to a grounded electrical source that has the following required service ratings:

Description	Requirements
Vac:	120
Hz:	50/60
Phase:	1
Circuit Breaker	5 Amp

To connect the junction box panel to the electrical source, do the following:

 **WARNING**



ELECTROCUTION HAZARD
Installing and servicing this equipment requires access to parts which could cause an electric shock or other serious injury. Have only qualified electricians access the control assembly.

1. Shut off system power at the main circuit breaker.
2. Remove the cover from the junction box panel.
3. Locate the PLC power terminals KS102 and KS100 on the terminal strip inside the junction box panel. See Fig. 5. For more information, refer to **Electrical Diagram** on page 14 .
4. Using the upper wire duct on the left-hand side of the junction box panel, string two 14 AWG wires inside the box from the electrical power source.

5. Connect the two 14 AWG wires to power terminals KS102 (L1, hot) and KS100 (L2, neutral) in the junction box panel.
6. Seal the area where wires entered the junction box panel.
7. Replace the cover on the junction box panel.

PLC Interface (253482 and 253701 only)

The junction box panel includes the following system components. For additional information, refer to the **Electrical Diagram** on page 14.

- System Pressurized lamp is lit when air pressure is supplied to the system; the lamp is extinguished when the air supply is depressurized. This occurs after the Pump On button has been pushed and the pumps turned on.
- Pump Active lamp is lit when the air supply is turned on to the pumps; the lamp is extinguished when the pumps are inactive, thus turned off. This is activated by the Pump On pushbutton.
- Air Pressure On lamp is lit when air pressure to the system is turned on; the lamp is extinguished when air pressure to the system is shutoff.
- Ram Ready lamp is lit when the drum is in position; the lamp is extinguished when the drum is not in position.
- Pump Ready lamp is lit when the pumps are primed and ready for operation; the lamp is extinguished when the pumps are not ready for operation.
- Prime Pump pushbutton turns on the pumps, for priming. When the pumps are primed, the Pump Ready lamp turns on. The switch is not used when the Pump Ready lamp is lit. The Pump Active light will blink.
- Pump Reset pushbutton resets the pumps to an active state. When the pumps are reset, the Pump Active lamp turns off. The switch is not used when the Pump Active lamp is lit. The Pump Ready light is on.
- Pump On pushbutton turns the pumps on and off. When the pumps are turned on, the Pump Active lamp also turns on. When the pumps are turned off, the Pump Active lamp also turns off.
- Bulk Supply Depressurization button opens the depressurization valve to lower the fluid pressure.
- Auto Mode On/Off switch puts the system into or out of automatic operation.

Installation

Connecting Power to the PLC Interface (continued)

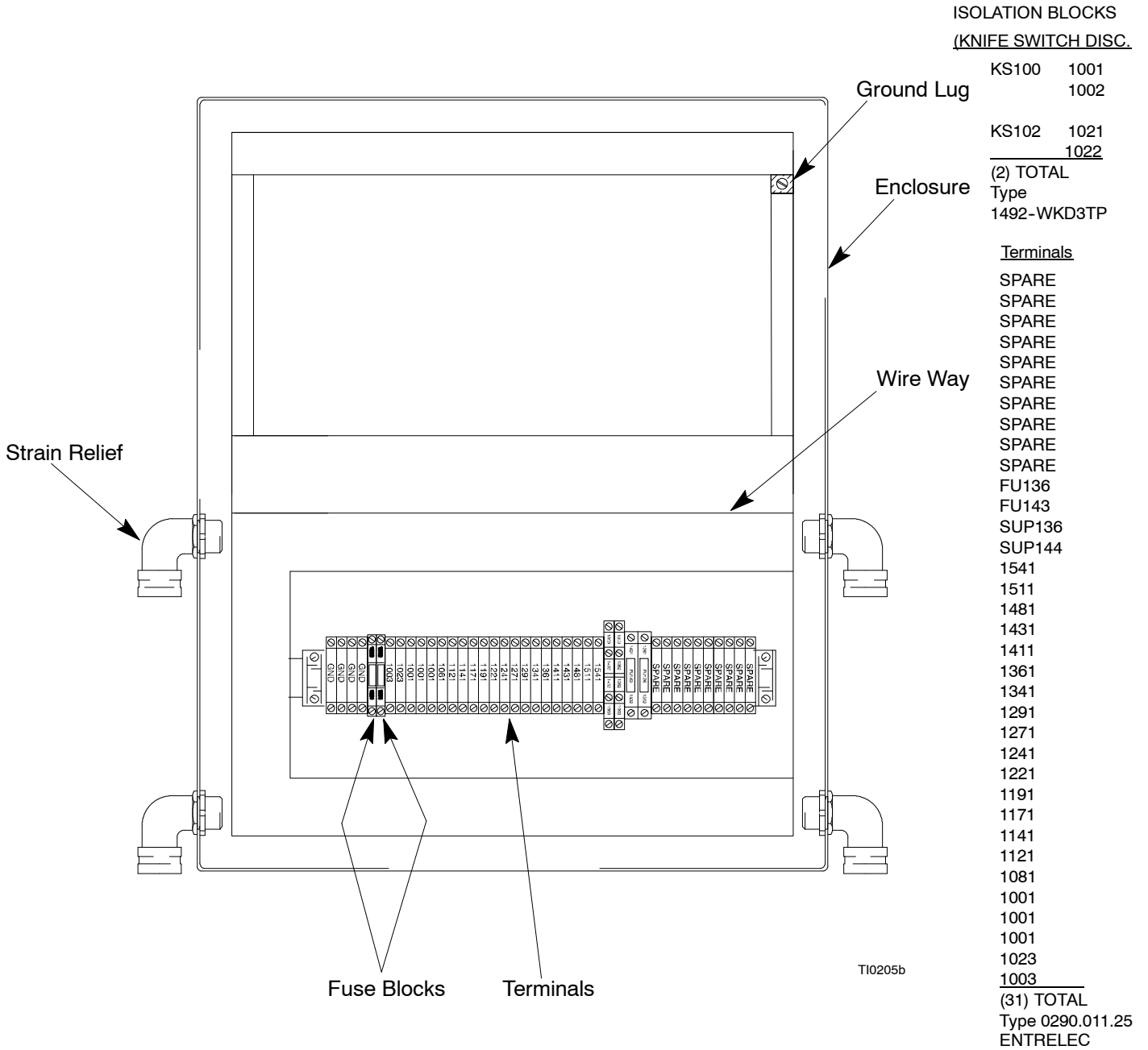
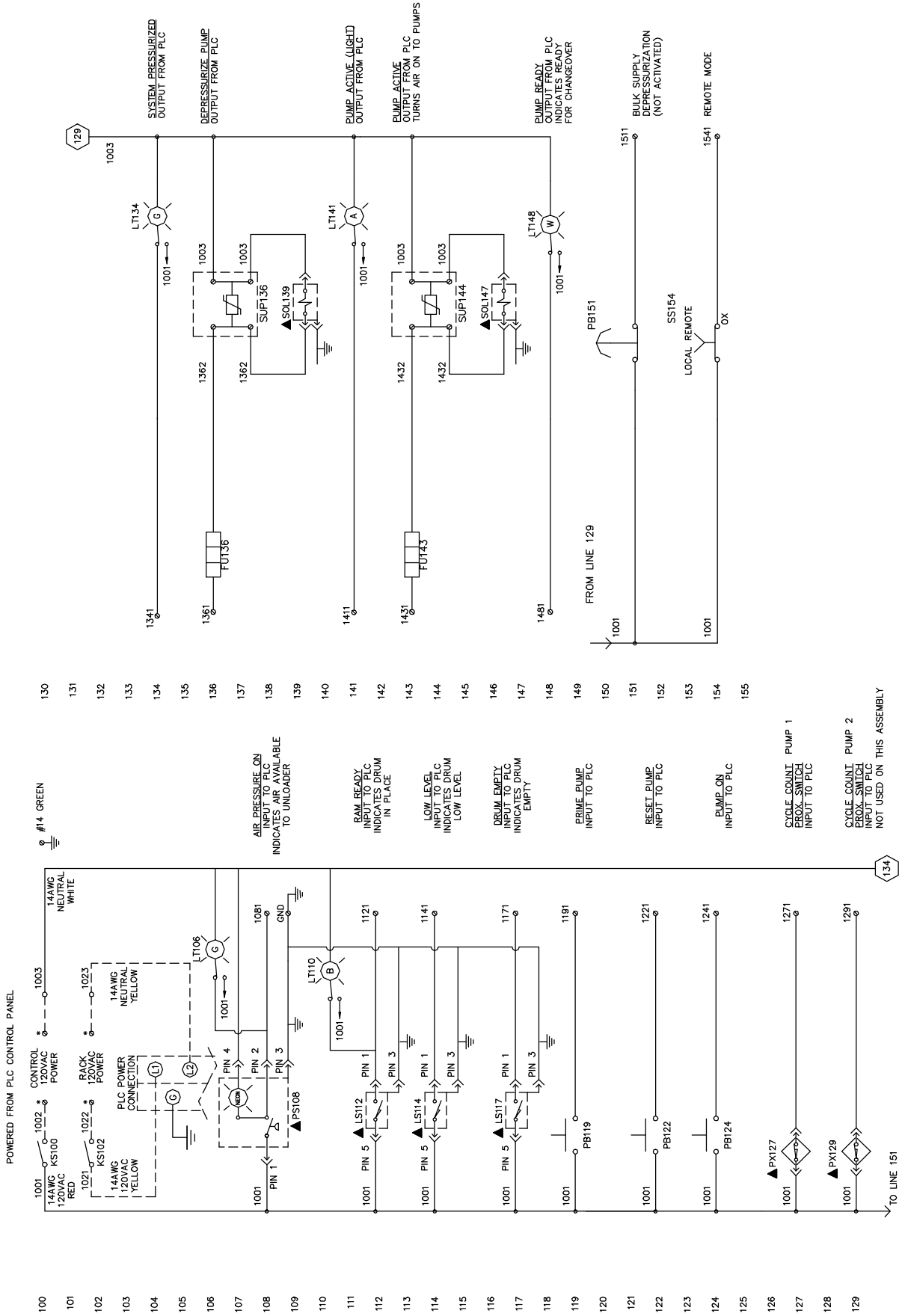
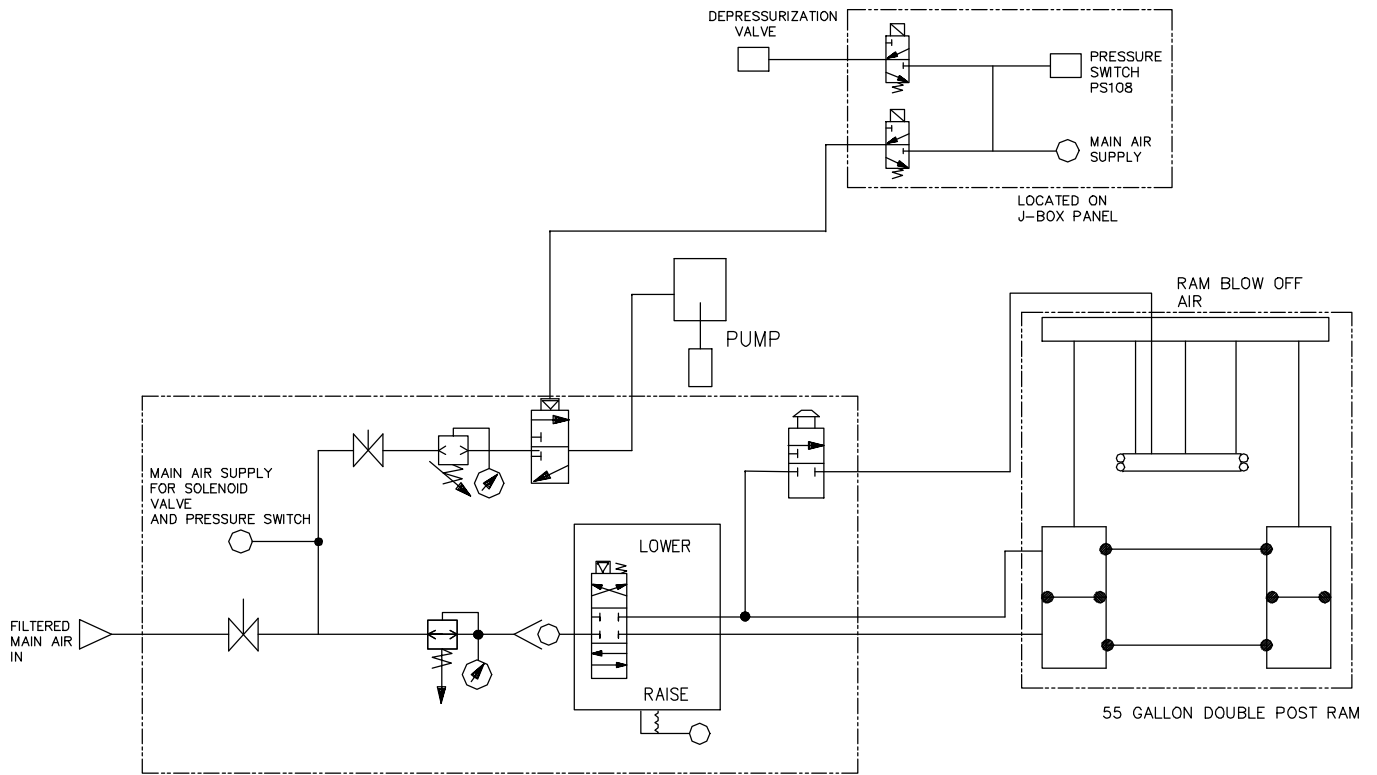

Fig. 5

Installation



Installation



Operation

Pressure Relief Procedure

WARNING



SKIN INJECTION HAZARD

The system pressure must be manually relieved to prevent the system from starting or spraying/dispensing accidentally. Fluid under high pressure can be injected through the skin and cause serious injury. To reduce the risk of an injury from injection, splashing fluid, or moving parts, follow the **Pressure Relief Procedure** whenever you

- Are instructed to relieve the pressure
- Stop spraying or dispensing
- Check or service any of the system equipment
- Install or clean the spray tip or nozzle

1. Lock the gun/valve trigger safety.
2. Close the pump air bleed valve (H, required in your system).
3. Shut off the main air bleed valve (E, required in your system). Set the ram director valve (U) to DOWN. The ram will slowly drop.
4. Unlock the gun/valve trigger safety.
5. Hold a metal part of the gun/valve firmly to the side of a grounded metal pail, and trigger the gun/valve to relieve pressure.
6. Lock the gun/valve trigger safety.
7. Open the drain valve (required in your system) and/or the pump bleeder valve (DD), having a container ready to catch the drainage.
8. Leave the drain valve open until you are ready to spray/dispense again.

If you suspect that the spray tip/nozzle or hose is completely clogged, or that pressure has not been fully relieved after following the steps above, very slowly loosen the tip guard retaining nut or hose end coupling and relieve pressure gradually. Then loosen it completely. Then clear the tip/nozzle or hose.

Starting and Adjusting the Ram

1. See Fig. 7. Close all air regulators and air valves.
2. Open the main air bleed valve (E), and set the ram air regulator (T) to 2.8 bar, 0.26 MPa (40 psi). Pull up on the director valve (U) handle so the arrow points to UP, and let the ram raise to its full height.
3. Set a full drum of fluid on the ram base, slide it back against the tube stop, and center it under the ram plate (C). Use the drum clamps (17) to center, hold, and properly align the drum with the ram.
4. Remove the drum cover, and smooth the surface of the fluid with a straightedge.
5. If drum has a plastic liner, pull it over edge of drum. Secure liner with duct tape wrapped around circumference of drum.

WARNING



MOVING PARTS HAZARD

Moving parts can pinch or amputate your fingers. When the pump is operating and when raising or lowering the ram, keep your fingers and hands away from the pump intake, ram plate, and lip of the drum.

NOTE: Do not use drums that have side bungs or large dents with this ram. Rough bung openings or large dents will damage the wipers or stop the ram plate, resulting in a runaway pump.

6. Push down on the director valve handle so the arrow points to DOWN, lower the ram until the ram plate is about to enter the drum, and set the valve to neutral. Reposition the drum as necessary so the wipers do not hit the drum lip, and open the vent valve (CC) on the ram plate.
7. Set the director valve to DOWN, and continue to lower the ram until fluid appears at the vent valve (CC). Set the director valve to neutral, and close the vent valve.

Operation

Starting and Adjusting the Ram (*continued*)

Adjusting the Low Limit Switch

NOTE: When the low limit switch is activated, the pumps are normally turned off automatically by a customer-supplied control, and a second set of pumps begin pumping.

8. Adjust the low limit switch as follows:

- a. At the junction box panel (see Fig. 8), set the RAM POSITION switch to LOWER, allowing the follower plate to activate the lower limit switch.

- b. Verify that the follower plate lowers to the limit set point: a level between 1–4 in. (25.4–101.6 mm) from the bottom of the drum.
- c. Adjust the low limit switch to activate at the level defined in step 8.b. See Fig. 6.

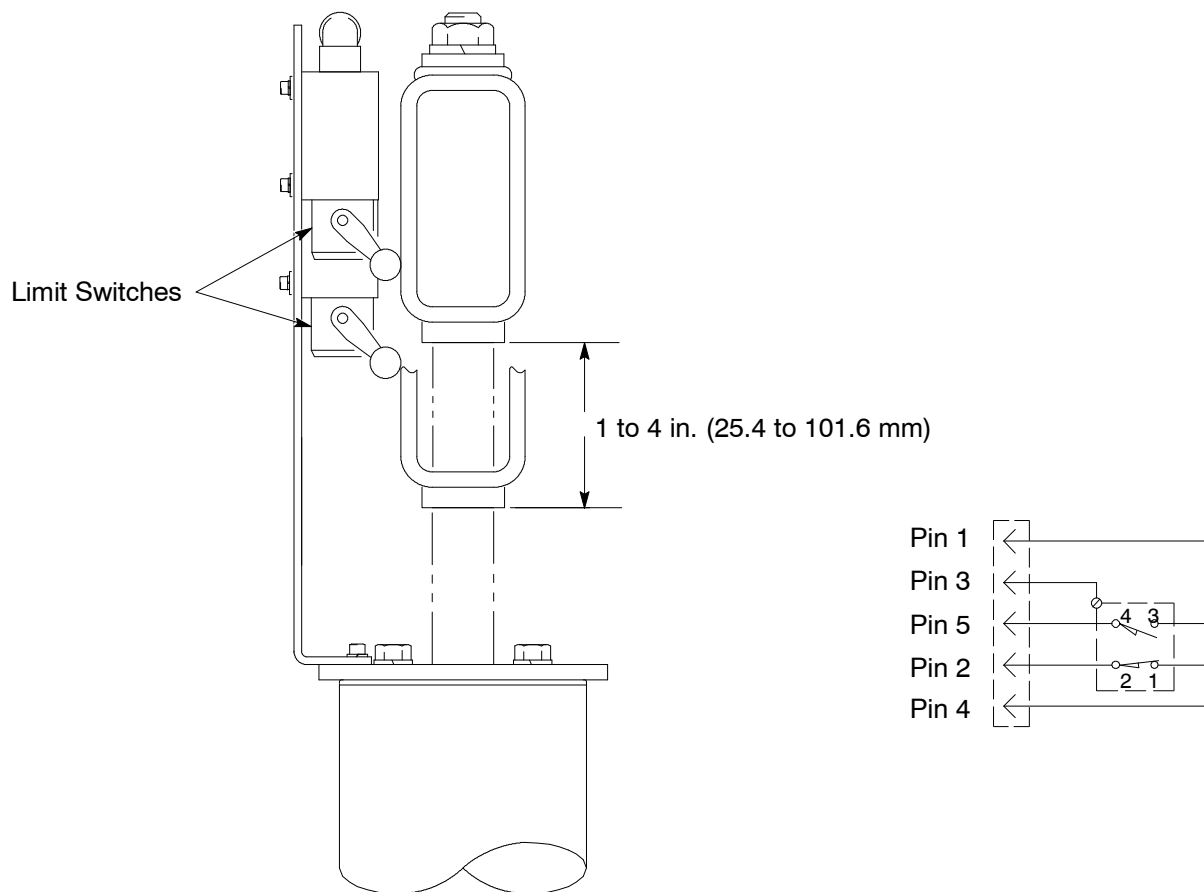

Fig. 6

TI0200

Operation

Model 236472 shown

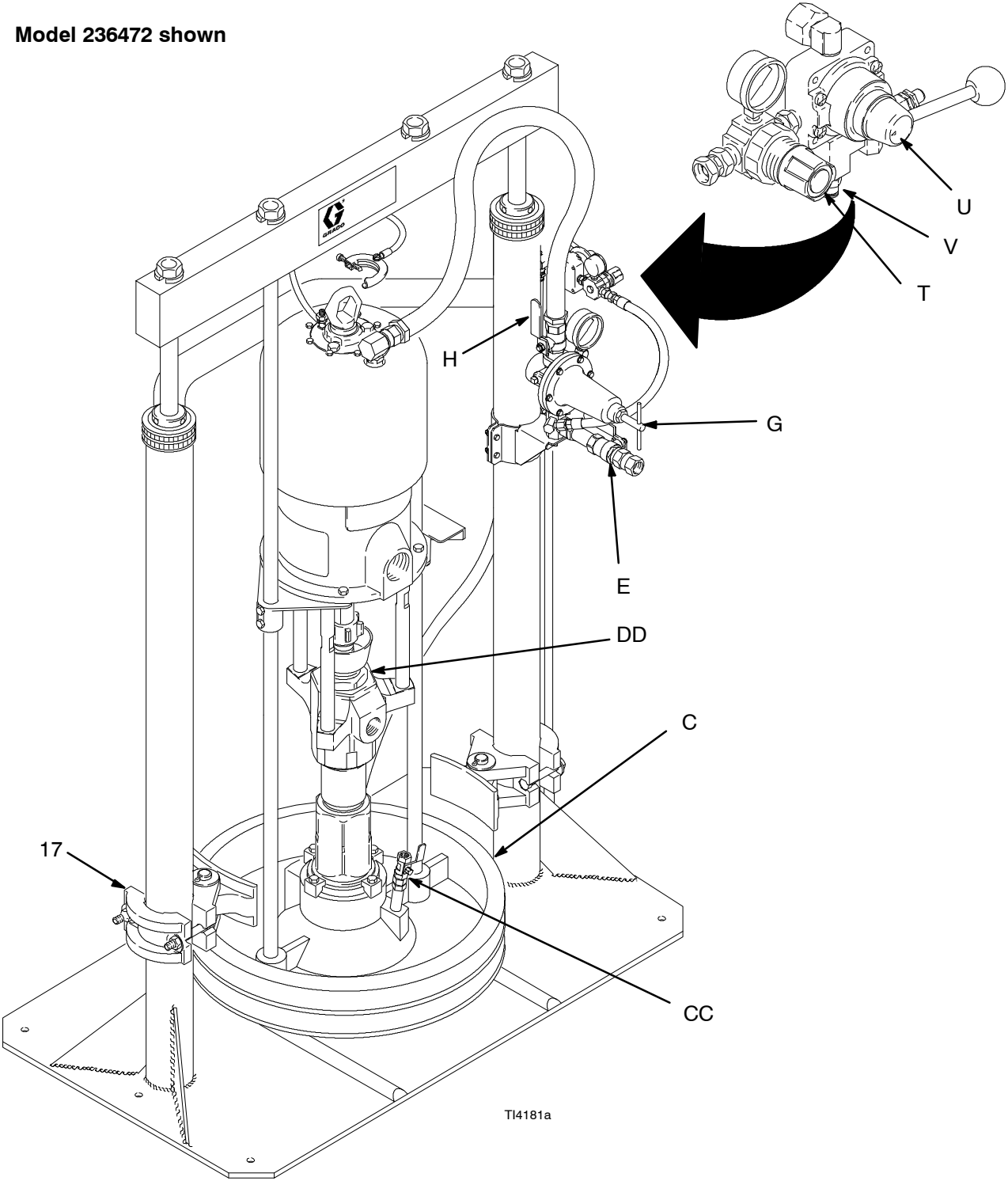

Fig. 7

Operation

Starting and Adjusting the Pump

1. Be sure the pump air regulator (G) is closed. Set the ram air regulator (T) to about 3.5 bar, 0.35 MPa (50 psi). Set the director valve (U) to DOWN. See Fig. 7.
2. Start the pump as explained in the separate pump instruction manual.
3. Keep the director valve (U) set to DOWN while the pump is operating.

NOTE: Increase air pressure to the ram if the pump does not prime properly with heavier fluids. If fluid is forced out around the top wiper, ram pressure is too high, and the air pressure should be decreased.

Changing Drums

⚠ WARNING

MOVING PARTS HAZARD
Moving parts can pinch or amputate your fingers. When the pump is operating and when raising or lowering the ram, keep your fingers and hands away from the pump intake, ram plate, and lip of the drum.



1. Stop pump.
2. Close pump air bleed valve (H).
3. Before raising wiper plate, locate push button on air release valve (V) .

4. Set director valve (U) to UP to raise wiper plate. At the same time, carefully equalize pressure in drum by operating air release valve.
5. Raise wiper plate until it is completely out of drum.
6. Remove empty drum.
7. Inspect wiper plate and, if necessary, remove any remaining material or material build-up.
8. Place full drum on ram base.
9. Lower the ram and adjust the position of the drum relative to the ram plate, as explained under **“Starting and Adjusting the Ram”** on page 16.

Shutdown and Care of the Pump

1. Set the director valve (U) to neutral.

⚠ WARNING

To reduce the risk of serious injury whenever you are instructed to relieve pressure, always follow the **Pressure Relief Procedure** on page 16.

2. **Relieve the pressure.**
3. Follow the pump shutdown instructions in your separate pump manual.

Operation

PLC Interface Switches and Indicators

Use the table and Fig. 8 when operating the switches and reading the indicator on the junction box panel.

Button/Switch	What it Does
PRIME PUMP pushbutton	<ul style="list-style-type: none"> Primes both displacement pumps with material, making the pumps ready to operate. Lights PUMP READY light.
PUMP RESET pushbutton	<ul style="list-style-type: none"> Restarts the pumps after the pumps were turned off. Lights PUMP ACTIVE light
PUMP ON pushbutton	<ul style="list-style-type: none"> Activates the pumps. Deactivates the pumps.
Bulk Supply Depressurization pushbutton	<ul style="list-style-type: none"> Opens the depressurization valve to lower the fluid supply pressure.
AUTO MODE ON/OFF switch	<ul style="list-style-type: none"> Places fluid dispensing system into Automatic or Manual mode.

Indicator	Indicator Light is	Meaning
SYSTEM PRESSURIZED light	ON	System is pressurized.
	OFF	System is depressurized.
PUMP ACTIVE light	ON	Pumps are active; air is available to the pumps.
	OFF	Pumps are inactive; air is unavailable to the pumps.
AIR PRESSURE ON light	ON	Air pressure is available to the pumps for use.
	OFF	Air pressure is not available to the pumps for use.
RAM READY light	ON	Follower plate is ready for use.
	OFF	Follower plate is not ready for use.
PUMP READY light	ON	Pumps are primed and ready to use.
	OFF	Pumps are not ready to use.

Operation

PLC Interface Switches and Indicators (continued)

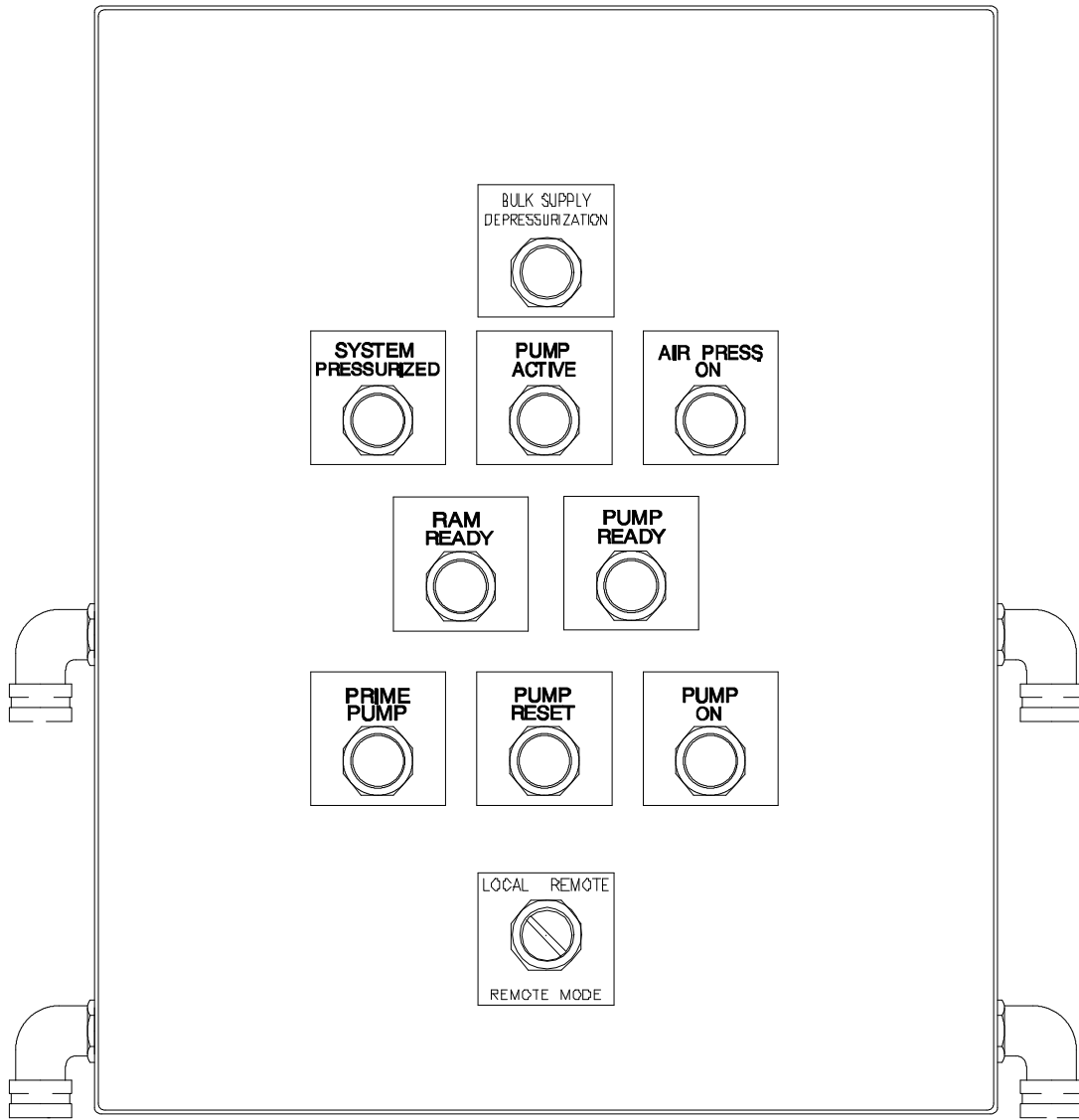

T10203

195320 Panel Shown

Fig. 8

PLC Interface Service

This part of the manual provides information about the following junction box panel components:

- Indicator light and pushbutton switch replacement
- Light bulb replacement
- Fuse replacement
- Surge suppressor replacement

NOTE: Refer to **PLC Interface Parts** on page 53 while servicing the junction box panel.

Indicator Light and Pushbutton Switch Removal

⚠ WARNING

ELECTROCUTION HAZARD
Installing and servicing this equipment requires access to parts which could cause an electric shock or other serious injury. Have only qualified electricians access the control assembly.

1. Shut off power to the junction box panel.
2. At the junction box panel, remove the cover from the junction box panel.
3. Disconnect the lead wires from the terminals on the switch. For wiring information, refer to the **Electrical Diagram** on page 14. If necessary, label the wires to facilitate reconnection after replacing the component.
4. Loosen two screws which clamp the fixture to the cover. Rotate and remove the outer ring on the defective component counterclockwise to remove the light lens or switch. Separate the parts and remove them from the cover.

Indicator Light and Pushbutton Switch Replacement

1. Reverse steps 2 through 4 in the previous paragraph.

2. For wiring information, refer to the **Electrical Diagram** on page 14.
3. Reapply power to the junction box panel.
4. Verify that the replaced component operates correctly.
5. Return the system to current readiness condition.

Light Bulb Removal

Remove the light bulb as follows:

⚠ WARNING

ELECTROCUTION HAZARD
Installing and servicing this equipment requires access to parts which could cause an electric shock or other serious injury. Have only qualified electricians access the control assembly.

1. Shut off power to the junction box panel.
2. Unscrew and remove the indicator light lens.
3. Gently press and rotate the bulb counterclockwise, 1/4-in. of a turn, unlocking the bulb from its socket. Remove the bulb from the socket.

Light Bulb Replacement

Replace the light bulb as follows:

1. Insert the light bulb in the socket.
2. Gently press and rotate the bulb clockwise, 1/4-in. of a turn to lock the bulb in its socket.
3. Replace the lens.
4. Reapply power to the junction box panel.
5. Verify that the light bulb operates correctly.
6. Return the system to current readiness condition.

PLC Interface Service

Fuse Removal

Remove the fuse as follows:

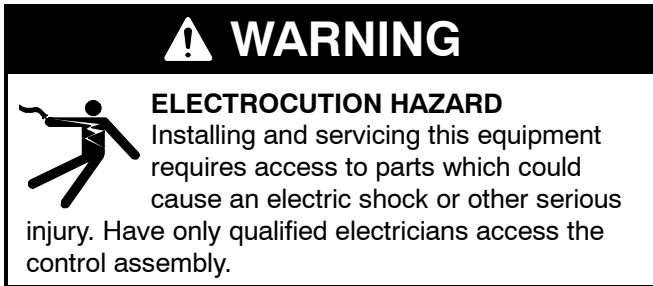

1. Shut off power to the junction box panel.
2. At the junction box panel, remove the cover from the junction box panel.
3. Locate the failed fuse on the terminal strip. Reference Fig. 8 for the fuse terminal identification.
4. Carefully remove the fuse from the fuse holder.

Fuse Replacement

Replace the fuse as follows:

NOTE: Check the new fuse to ensure that it matches the amp rating of the failed fuse.

1. Press both ends of the new fuse evenly into place in the fuse holder. See Fig. 8.
2. Reinstall the cover on the junction box panel.
3. Reapply power to the junction box panel.
4. Verify that the fuse operates correctly.
5. Return the system to current readiness condition.

PLC Interface Troubleshooting

Problem	Cause(s)	Solution(s)
Power from PLC control panel is ON, but no indicator lights are lit at junction box panel.	The knife switch disconnect contacts (KS100 and KS102) are open.	Check the PLC power connections at customer's site.
	One or more fuses blown.	Replace the blown fuse(s). Check FU136 and FU143 located inside the knife switch disconnect blocks.
	Voltage limit to circuits in junction box panel was exceeded.	Check the surge suppressors SUP136 and SUP144. Replace if required. Reset power to unit.

PLC Interface Service

Surge Suppressor Removal

Remove the surge suppressor as follows:

⚠ WARNING

ELECTROCUTION HAZARD
Installing and servicing this equipment requires access to parts which could cause an electric shock or other serious injury. Have only qualified electricians access the control assembly.

1. Shut off power to the junction box panel.
2. At the junction box panel, remove the cover off the junction box panel.
3. Locate the failed surge suppressor on the terminal strip. Reference Fig. 8 for the surge suppressor terminal identification.
4. Remove the two screws and surge suppressor from the terminal strip.

Surge Suppressor Replacement

Replace the surge suppressor as follows:

1. Install the new surge suppressor into place on the terminal strip using the two screws. See Fig. 8.
2. Reinstall the cover on the junction box panel.
3. Reapply power to the junction box panel.
4. Verify that the new surge suppressor operates correctly.
5. Return the system to current readiness condition.

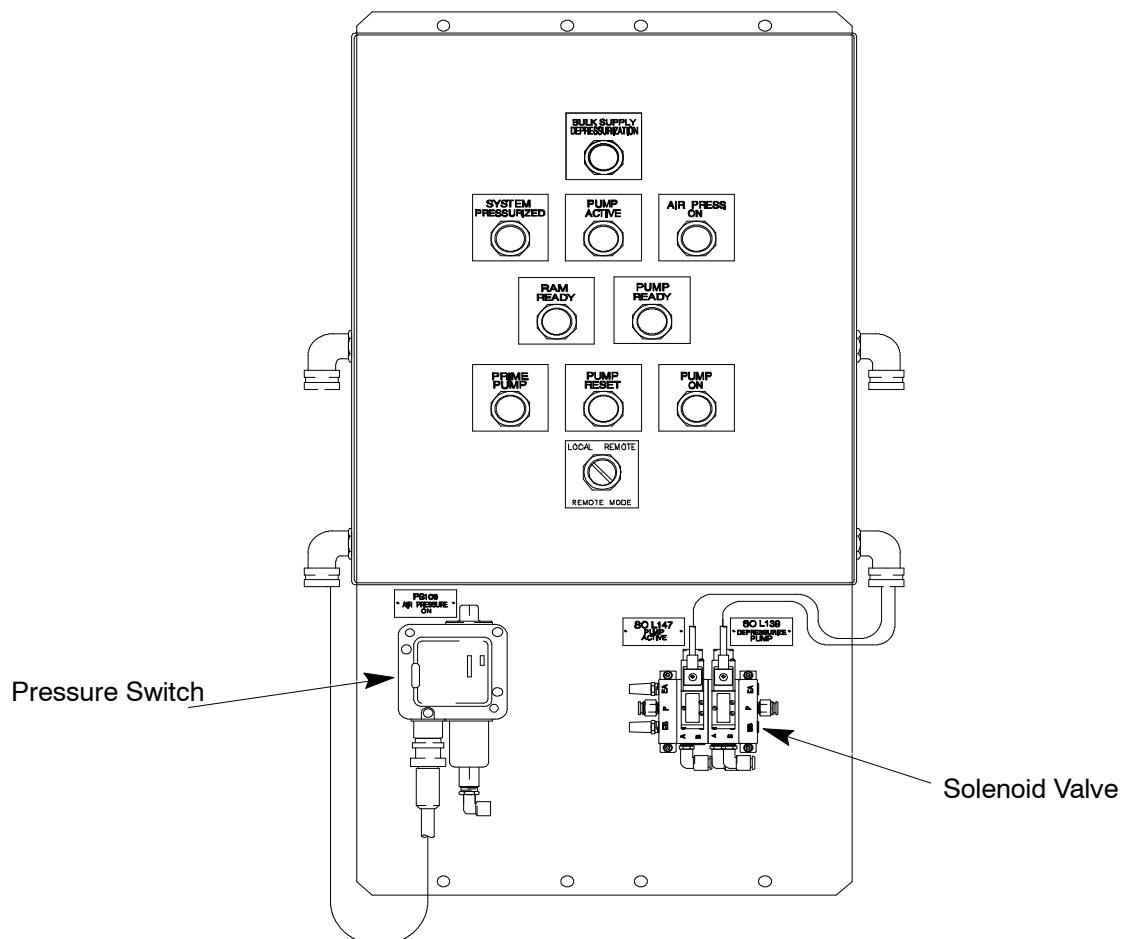

Fig. 9

T10196

PLC Interface Accessory Kit Service

This part of the manual provides information about the following PLC interface accessory kit components:

- Valve assembly bank replacement
- Pressure switch assembly replacement

Valve Assembly Bank Replacement

Remove the valve assembly bank that is mounted below the junction box panel as follows:

NOTE: The valve assembly bank has two solenoids (SOL139 and SOL147) that are used as switches to control pump operation. SOL139 depressurizes the pumps. SOL147 turns air on to the pumps.

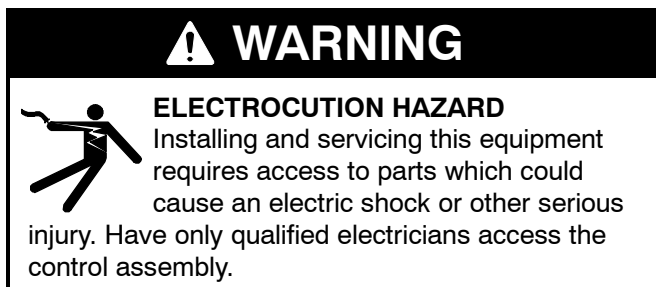

1. Shut off power to the junction box panel.

Valve Assembly Removal

2. At the junction box panel, remove the cover off the junction box panel.
3. Locate the valve assembly (203) that is attached to the mounting plate (201) below the junction box panel (217). See Fig. 9.
4. Disconnect the two cables (216) from the terminal strip inside the junction box panel (217) for the valve assembly (203) bank. For wiring information, refer to the **Electrical Diagram** on page 14.
5. Remove four cap screws (205), the lock washers (206), and the valve assembly (203) from the mounting plate (201).

Valve Assembly Replacement

6. Install the new valve assembly (203) on the mounting plate (201) using the four cap screws (205) and lock washers (206). See Fig. 9.
7. Reconnect the two cables (216) on the terminal strip inside the junction box panel (217) for the valve assembly (203) bank. For wiring information, refer to the **Electrical Diagram** on page 14.

This part of the manual provides information about the following PLC interface accessory kit components:

- Valve assembly bank replacement
- Pressure switch assembly replacement

Valve Assembly Bank Replacement

Remove the valve assembly bank that is mounted below the junction box panel as follows:

NOTE: The valve assembly bank has two solenoids (SOL139 and SOL147) that are used as switches to control pump operation. SOL139 depressurizes the pumps. SOL147 turns air on to the pumps.

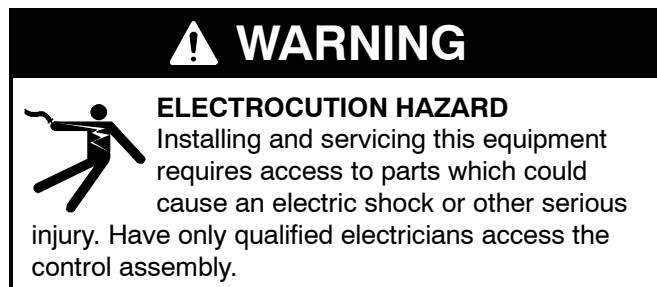

1. Shut off power to the junction box panel.

Valve Assembly Removal

2. At the junction box panel, remove the cover off the junction box panel.
3. Locate the valve assembly (203) that is attached to the mounting plate (201) below the junction box panel (217). See Fig. 9.
4. Disconnect the two cables (216) from the terminal strip inside the junction box panel (217) for the valve assembly (203) bank. For wiring information, refer to the **Electrical Diagram** on page 14.
5. Remove four cap screws (205), the lock washers (206), and the valve assembly (203) from the mounting plate (201).

Valve Assembly Replacement

6. Install the new valve assembly (203) on the mounting plate (201) using the four cap screws (205) and lock washers (206). See Fig. 9.
7. Reconnect the two cables (216) on the terminal strip inside the junction box panel (217) for the valve assembly (203) bank. For wiring information, refer to the **Electrical Diagram** on page 14.

Parts

Model 223816, Series B 10:1 Ratio Monark Pump

Ref No.	Part No.	Description	Qty	Ref No.	Part No.	Description	Qty
1	207279	RAM, drum, 200 liter (55 gal.) See 306934 for parts	1	20	200033	. HOSE; neoprene; 1/4 in. (6 mm) ID; coupled 1/4 npt (mbe); 1.8 m (6 ft) long	1
2	222770	10:1 RATIO MONARK PUMP See 308017 for parts	1	21	112040	. ELBOW, fluid outlet, 90°; 3/4 npt(fbe)	1
3	222776	KIT, mounting; Includes items 4 to 6	1	22	162505	. ADAPTER, air inlet; 3/8 npt(m) x 1/2 npt(f) swivel; for use with Monark Pump only	1
4	102637	. SCREW, cap, hex hd; 3/8-16 unc-2a x 38 mm (1.5 in.) long	4		156684	. ADAPTER, air inlet; 1/2 npt(m) x 1/2 npt(f) swivel; not used on this pump	1
5	276025	. LUG	4				
6	184086	. GASKET; PTFE	1				
7	223815	AIR REGULATION KIT Includes items 8 to 16	1	23	208434	. ADAPTER, swivel, straight; 1/8 npt(m) x 1/4 npsm(f) swivel	1
8	162376	. MANIFOLD, air, swivel; 1/2 npt(m) x 1/2 npt(f) swivel; three 1/8 npt(f) ports	1	24	100896	. BUSHING; 3/4 npt(m) x 1/2 npt(f)	1
9	100960	. GAUGE, air pressure; 0-14 bar, 0-1.4 MPa (0-200 psi)	1	30	224829	RAM MOUNTING KIT Includes items 31 to 37; additional kit parts are not used with this pump; see page 59 for complete list	1
10	100840	. ELBOW, street, 90°; 1/4 npt(m x f)	1				
11	107142	. VALVE, bleed-type; 1/2 npt(m x f)	1	31	100133	. WASHER, spring lock; 3/8 in. (9.5 mm)	4
12	158491	. NIPPLE; 1/2 npt	1				
13	155470	. UNION, adapter; 1/2 npt(m) x 1/2 npsm(f) swivel	1	32	184140	. PLATE, mounting, pump	1
14	104266	. AIR REGULATOR See 308167 for parts	1	33	100101	. CAPSCREW, hex hd; 3/8-16 unc-2a x 1 in. (25 mm) long	4
15	100721	. PLUG, pipe, headless; 1/4 npt	1	34	100016	. LOCKWASHER, spring; 1/4 in. (6.3 mm)	2
16	104765	. PLUG, pipe, headless; 1/8 npt	2	36	102313	. CAPSCREW, hex hd; 1/4-20 x 1-3/4 in. (45 mm)	2
17	206537	CLAMP, drum (set of two)	1				
18	223881	KIT, accessory, ram Includes items 19 to 24	1	37	102025	. NUT, hex; 1/4-20	2
19	155541	. ADAPTER, swivel, 90°; 1/4 npt(m) x 1/4 npsm(f) swivel; not used on this pump	1				

Parts

Model 223817, Series C
Model 253018, Series A
Model 234369, Series A
20:1 Ratio President Pump

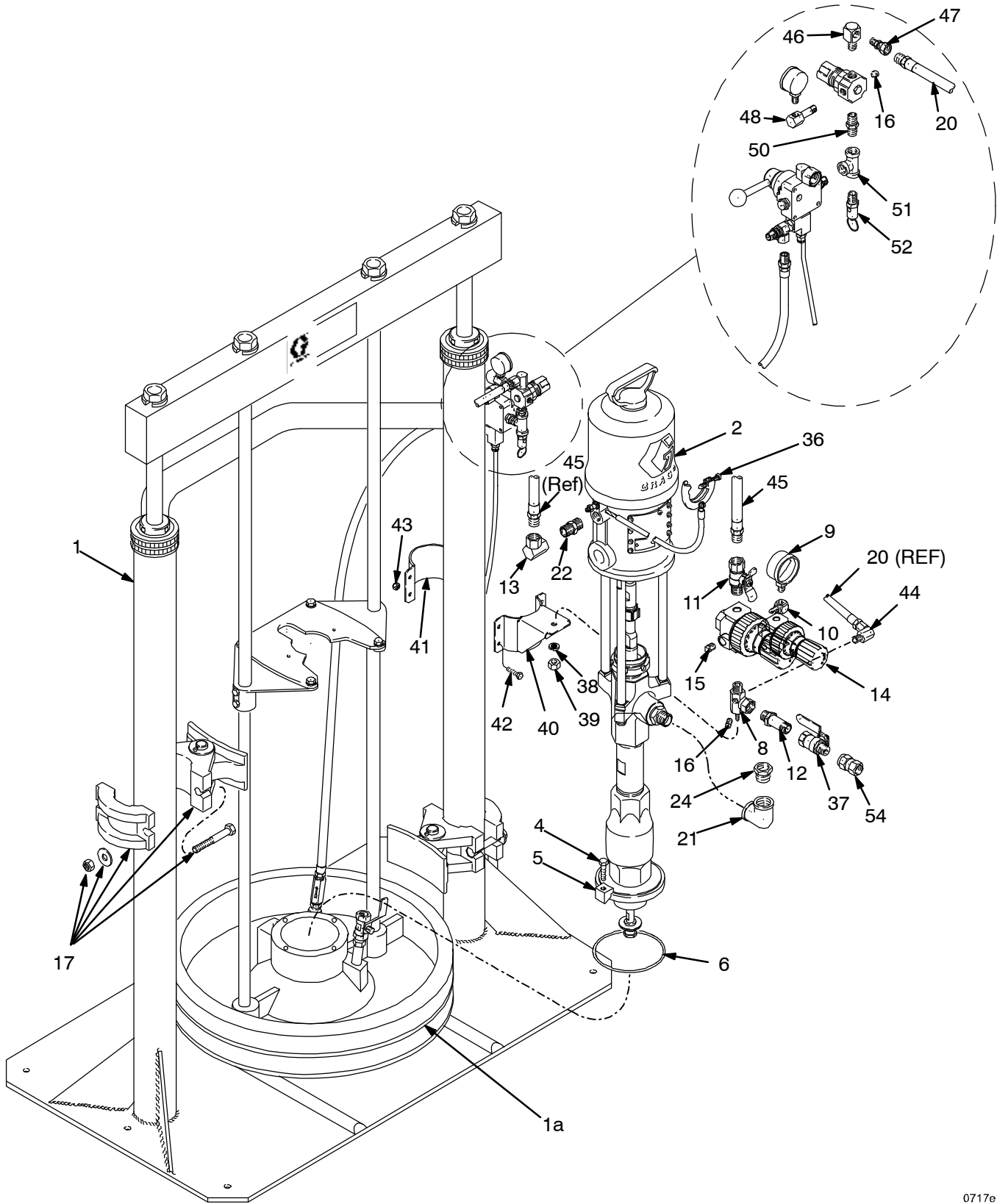

0717e

Parts

Model 223817, Series C
Model 253018, Series A
Model 234369, Series A
20:1 Ratio President Pump

Ref No.	Part No.	Description	Qty	Ref No.	Part No.	Description	Qty
1	207279	RAM, drum, 200 liter (55 gal.) See parts in 306934	1	21	112040	ELBOW, fluid outlet, 90°; 3/4 npt(fbe)	1
1a	248088	PLATE, ram (Model 234369 only)	1	22	100122	NIPPLE, close; 1/2 npt(m x 2)	1
	C56135	PLATE, 200 liter (55 gal.) ram; PTFE (Model 253018 only)	1	24	100896	BUSHING; 3/4 npt(m) x 1/2 npt(f)	1
2	222768	20:1 RATIO PRESIDENT PUMP (Models 223817 and 253018 only) See 308017 for parts	1	34	100016	LOCKWASHER, spring; 1/4 in. (6.3 mm)	2
	246933	20:1 RATIO PRESIDENT PUMP (Model 234369 only) See 308017 for parts	1	35	100270	CAPSCREW, hex hd; 1/4-20 x 5/8 in. (16 mm)	2
4	102637	SCREW, cap, hex hd; 3/8-16 unc-2a x 38 mm (1.5 in.) long	4	36	237569	GROUND WIRE	1
5	276025	LUG	4	37	113269	VALVE, bleed type; red handled; 1/2 npt(m x f)	1
6	109495	O-RING; fluoroelastomer	1	38	100322	WASHER, lock	2
8	206205	MANIFOLD, air, swivel; 1/2 npt(m) x 3/4 npsm	1	39	100131	NUT, hex; 3/8-16 unc-2b	1
9	100960	GAUGE, air pressure; 0-14 bar, 0-1.4 MPa (0-200 psi)	1	40	237962	BRACKET, welded	1
10	100840	ELBOW, street, 90°; 1/4 npt(m x f)	1	41	190747	BRACKET, ram	1
11	107142	VALVE, bleed-type; 1/2 npt(m x f)	1	42	100021	SCREW, cap; 1/4-20 unc-2a	4
12	190864	NIPPLE, reducing; 1/2 npt x 3/4 npt	1	43	102040	NUT, lock; 1/4-20 unc-3b	4
13	157416	UNION, swivel, 90°; 1/2 npt x 1/2 npsm	1	44	155541	UNION, swivel, 90°; 1/4 npt x 1/4 npsm	1
14	104266	AIR REGULATOR See 308167 for parts	1	45	205418	HOSE, coupled; buna n/pvc; 1/2 in. (13 mm) ID; 1.8 m (6 ft.) long	1
15	100509	PLUG, pipe; 1/4 nptf	1	46	187357	ELBOW, street	1
16	100403	PLUG, pipe; 1/8 nptf	2	47	156823	UNION, swivel	1
17	206537	CLAMP, drum (set of two)	1	48	160701	ELBOW, street, 90°; 1/8 npt(m x f)	1
20	109123	HOSE, coupled; buna-n; 1/4-18 npt(m x 2); 1/4 in. (6 mm) ID; 18.0 in. (0.46 m) long	1	50	156971	NIPPLE; 1/4 npt	1
				51	104984	TEE; 1/4 npt(f)	1
				52	113286	VALVE, safety; 1/4 npt(m); 10.4 bar, 1.04 MPa (150 psi)	1
				54	155865	UNION, adapter, swivel; 1/2 npt(f) x 1/2 npsm(f)	1

Parts

Model 234120, Series A

46:1 Ratio President Pump

Model 247156, Series A

46:1 Ratio President Pump, PTFE

Model 257589

50:1 Ratio FireBall 425 Pump

Model 234121, Series A

23:1 Ratio Monark Pump

Model 247155, Series A

23:1 Ratio Monark Pump, PTFE

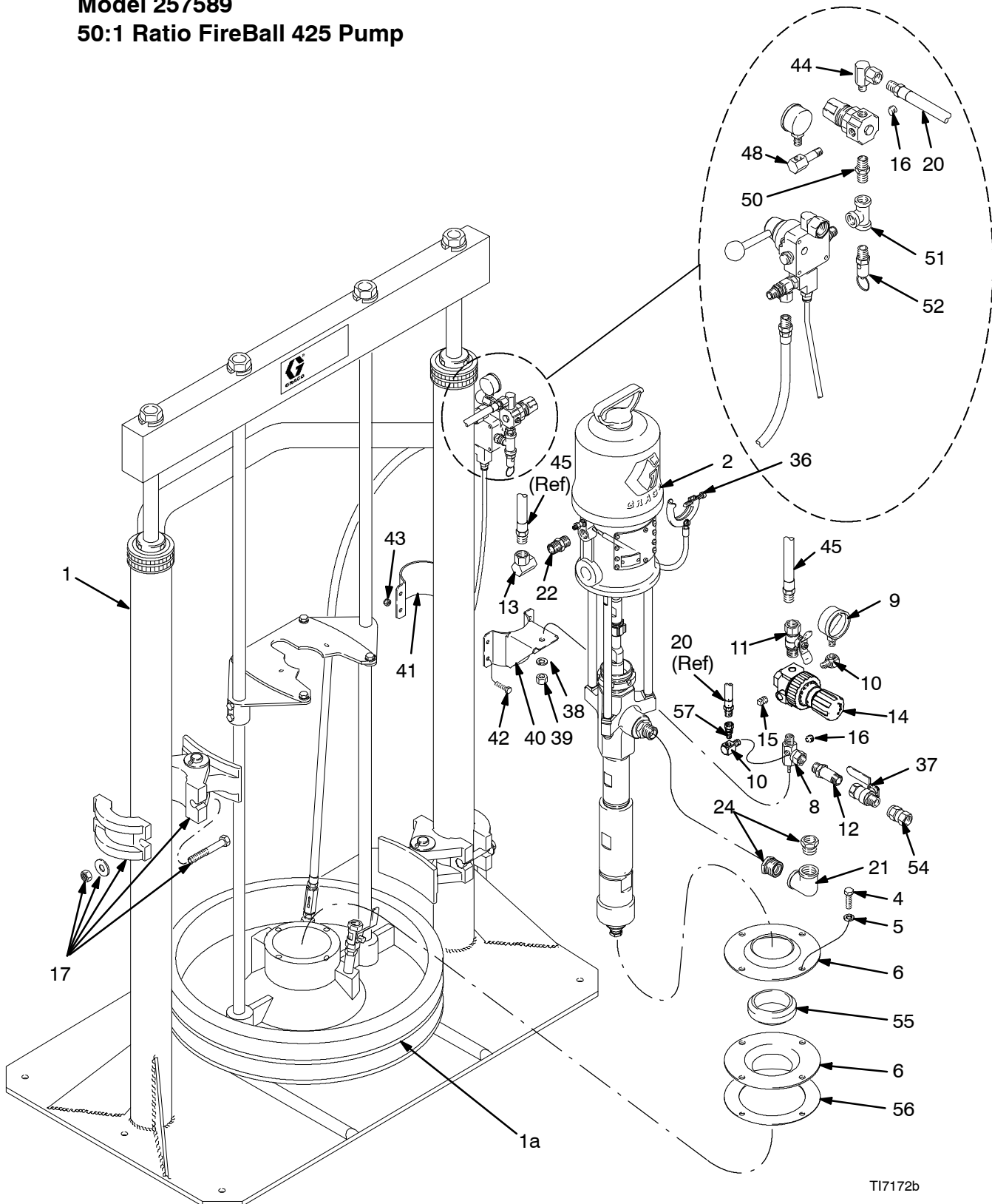

TI7172b

Parts

Model 234120, Series A 46:1 Ratio President Pump

Model 247156, Series A 46:1 Ratio President Pump, PTFE

Model 257589 50:1 Ratio FireBall 425 Pump

Model 234121, Series A 23:1 Ratio Monark Pump

Model 247155, Series A 23:1 Ratio Monark Pump, PTFE

Ref No.	Part No.	Description	Qty	Ref No.	Part No.	Description	Qty
1	215335	RAM, drum, 200 liter (55 gal.) See parts in 306934	1	22	100122	NIPPLE, close; 1/2 npt(m x 2) (Model 234120 only)	1
1a	238929	PLATE, ram, 200 liter (55 gal.) (234120, 234121, 257589 only)	1		159239	NIPPLE, pipe; 1/2 x 3/8npt (Model 234121 only)	1
	C56135	PLATE, ram, 200 liter, (55 gal.), PTFE (247155, 247156 only)	1	24	100896	BUSHING; 3/4 npt(m) x 1/2 npt(f)	2
2	237205	46:1 RATIO PRESIDENT PUMP (234120 only) See 308080 for parts	1	34	100016	LOCKWASHER, spring; 1/4 in. (6.3 mm)	2
	222907	46:1 RATIO PRESIDENT PUMP (247156 only) See 308200 for parts	1	35	100270	CAPSCREW, hex hd; 1/4-20 x 5/8 in. (16 mm)	2
	205395	50:1 RATIO FireBall 425 PUMP (257589 only) See 306674 for parts	1	36	237569	GROUND WIRE	1
	222782	23:1 RATIO MONARK PUMP (234121 only) See 308080 for parts	1	37	113269	VALVE, bleed type; red handled; 1/2 npt(m x f)	1
	222839	23:1 RATIO MONARK PUMP (247155 only) See 308200 for parts	1	38	100322	WASHER, lock	2
4	100004	SCREW, cap, hex hd; 3/8-16 unc-2a x 32 mm (1.25 in.) long	4	39	100131	NUT, hex; 3/8-16 unc-2b	1
5	100133	WASHER, lock; 3/8	4	40	237962	BRACKET, welded	1
6	162789	PLATE, seal	2	41	190747	BRACKET, ram	1
8	206205	MANIFOLD, air, swivel; 1/2 npt(m) x 3/4 npsm	1	42	100021	SCREW, cap; 1/4-20 unc-2a	4
9	100960	GAUGE, air pressure; 0-14 bar, 0-1.4 MPa (0-200 psi)	1	43	102040	NUT, lock; 1/4-20 unc-3b	4
10	187357	ELBOW, street, 90°; 1/4 npt(m x f)	2	44	155541	UNION, swivel, 90°; 1/4 npt x 1/4 npsm	1
11	107142	VALVE, bleed-type; 1/2 npt(m x f)	1	45	205418	HOSE, coupled; buna n/pvc; 1/2 in. (13 mm) ID; 1.8 m (6 ft.) long	1
12	190864	NIPPLE, reducing; 1/2 npt x 3/4 npt	1	48	160701	ELBOW, street, 90°; 1/8 npt(m x f)	1
13	157416	UNION, swivel, 90°; 1/2 npt x 1/2 npsm	1	50	156971	NIPPLE; 1/4 npt	1
14	104266	AIR REGULATOR See 308167 for parts	1	51	104984	TEE; 1/4 npt(f)	1
15	100509	PLUG, pipe; 1/4 nptf	1	52	113286	VALVE, safety; 1/4 npt(m); 10.4 bar, 1.04 MPa (150 psi)	1
16	100403	PLUG, pipe; 1/8 nptf	2		116643	VALVE, safety; 1/4 npt(m); 6.2 bar, .62 MPa (90 psi) (257589 only)	1
17	206537	CLAMP, drum (set of two)	1	54	155865	UNION, adapter, swivel; 1/2 npt(f) x 1/2 npsm(f)	1
20	109123	HOSE, coupled; buna-n; 1/4-18 npt(m x 2); 1/4 in. (6 mm) ID; 18.0 in. (0.46 m) long	1	55	161452	SEAL, follow plate	1
21	112040	ELBOW, fluid outlet, 90°; 3/4 npt(fbe)	1	56	162788	GASKET	1
				57	156823	UNION, swivel	1

Parts

Model 570114, Series A 20:1 Ratio Check-Mate Pump

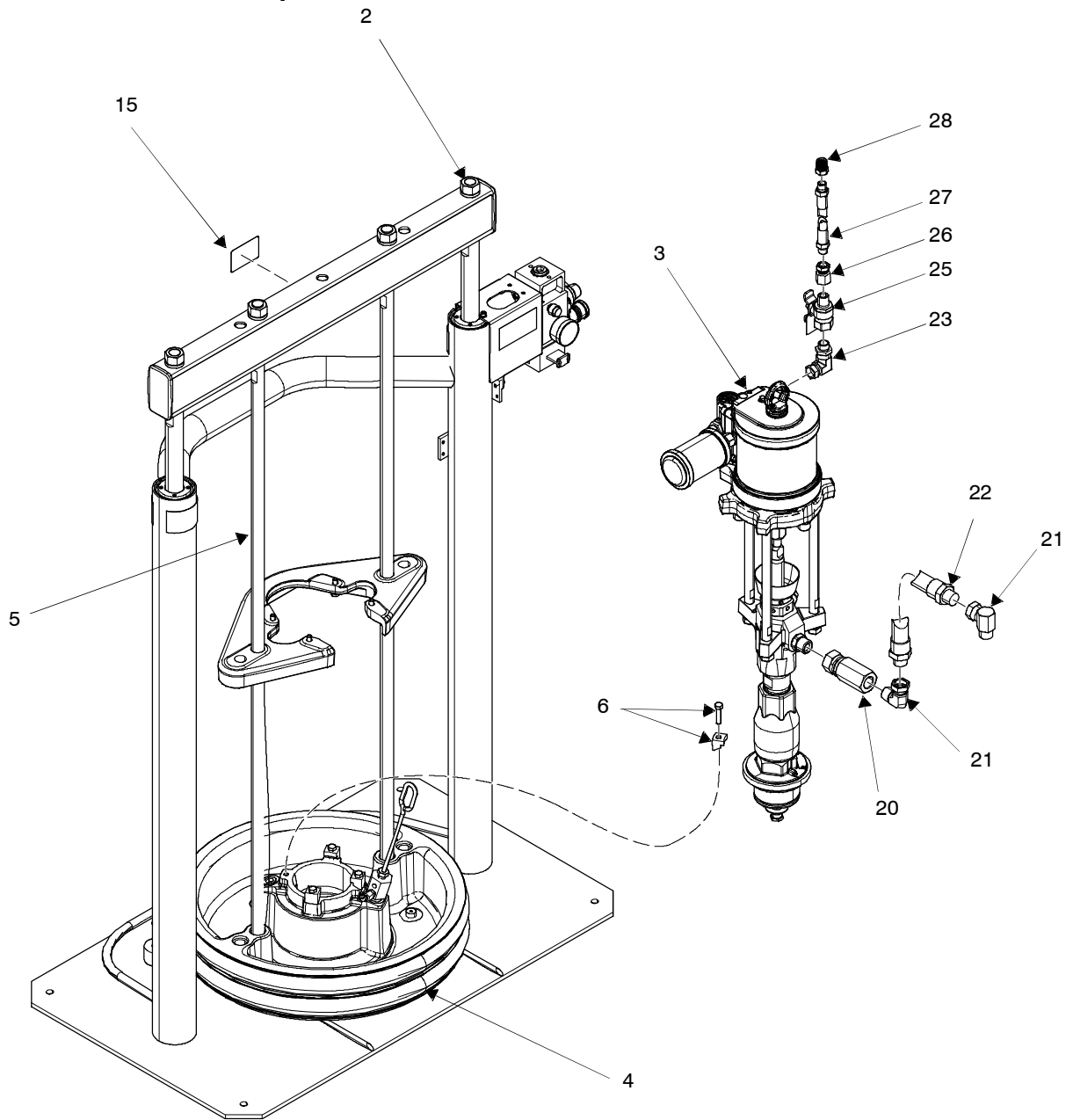

Parts

Model 570114 20:1 Ratio Check-Mate Pump

Ref No.	Part No.	Description	Qty
2	24C769	RAM, 3" int air, (no pump reg)	1
3	P20LCS	PUMP, 20:1 700/060 l cs s	1
4	255319	PLATE, wiper 55gal epdm	1
5	257299	KIT, d200, 200l, 700-1800	1
6	255392	KIT, mounting, cm lower	1
6a	102637	SCREW	1
6b	276025	CLAMP	1
6c	109495	O-RING	1
7	206537	CLAMP, drum, set of 2 (not shown)	1
9	100132	WASHER, flat (not shown)	4
10	100464	SCREW, lag (not shown)	4
15	292735	ARTWORK, identification	1
17	070408	SEALANT, pipe, sst	1
20	220179	VALVE, check	1
21	160327	FITTING, union adapter, 90 deg	2
22	236422	HOSE, coupled 61220	1
23	100122	NIPPLE, close	2
24	157416	FITTING, swivel, union, 90 deg	1
25	107142	VALVE, ball, vented	1
26	161077	FITTING, union, adapter, straight	1
27	214651	HOSE, coupled 61209	1
28	158212	BUSHING	1
31	237569	WIRE, assy, 25 ft	1
32	070182	TAPE, electrical	1
33	206994	FLUID, tsl 8 oz bottle	1

Parts

Model 96572, Series A 40:1 Ratio Check-Mate Pump

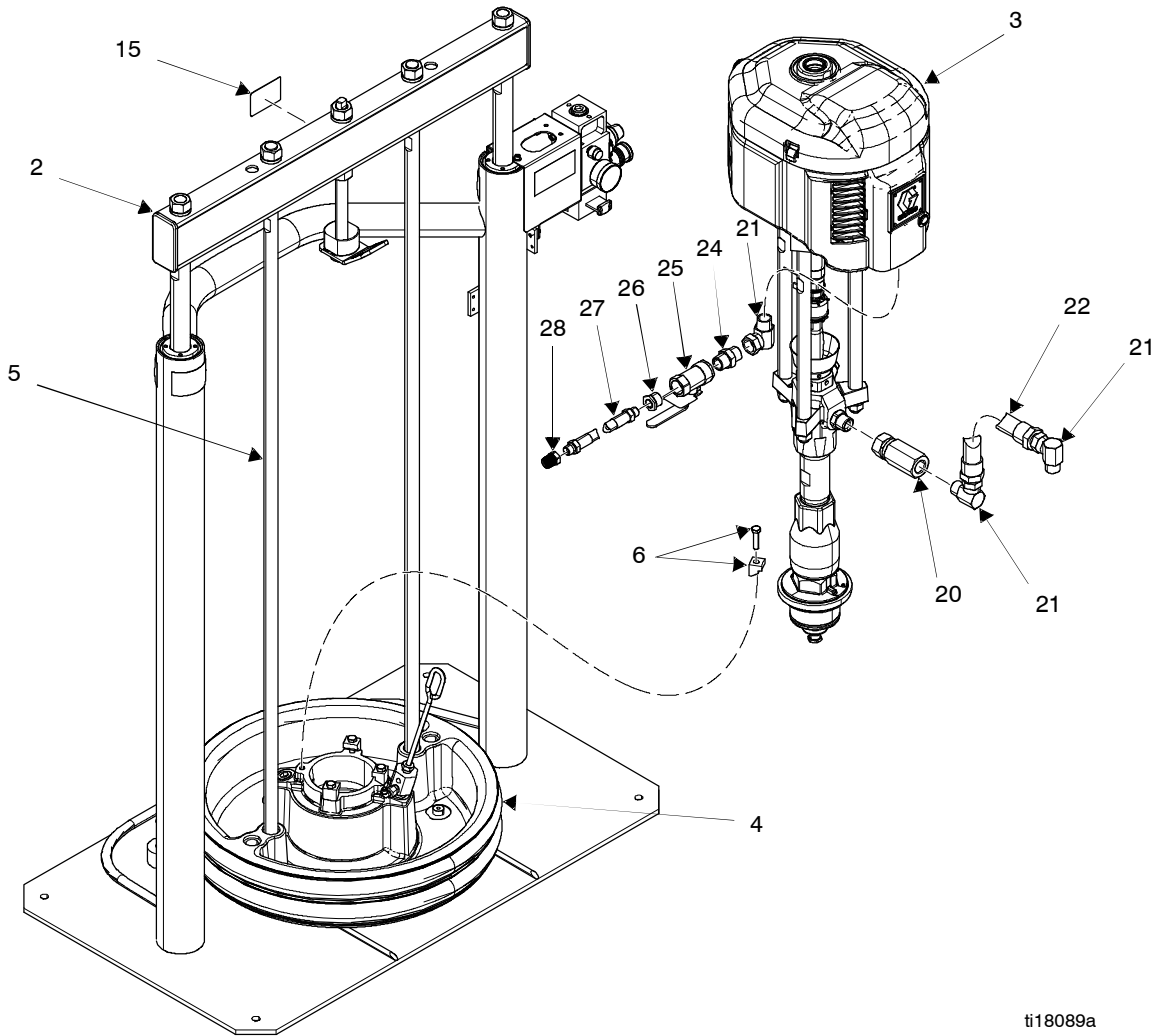

ti18089a

Parts

Model 965572, Series A 40:1 Ratio Check-Mate Pump

Ref No.	Part No.	Description	Qty
2	24C769	RAM, 3" int air, (no pump reg)	1
3	P40LCS	PUMP, 40:1 2200/100 cs sd	1
4	255319	PLATE, wiper 55gal epdm	1
5	255305	KIT, mounting nxt 3in 55gal	1
6	255392	KIT, mounting, cm lower	1
7	206537	CLAMP, drum, set of 2	1
9	100132	WASHER, flat	4
10	100464	SCREW, lag	4
15	292735	ARTWORK, identification	1
17	070408	SEALANT, pipe, sst	1
20	220179	VALVE, check	1
21	160327	FITTING, union adapter, 90 deg	3
22	236422	HOSE, coupled, 61220	1
24	C20487	FITTING, nipple, hex	1
25	113332	VALVE, ball, vented, .750	1
26	100505	BUSHING, pipe	1
27	214651	HOSE, coupled, 61209	1
28	158212	BUSHING	1
31	237569	WIRE, assy, 25 ft	1
32	070182	TAPE, electrical	1
33	206994	FLUID, tsl 8 oz bottle	1

Parts

Model 234371, Series A 12:1 Ratio Bulldog Pump

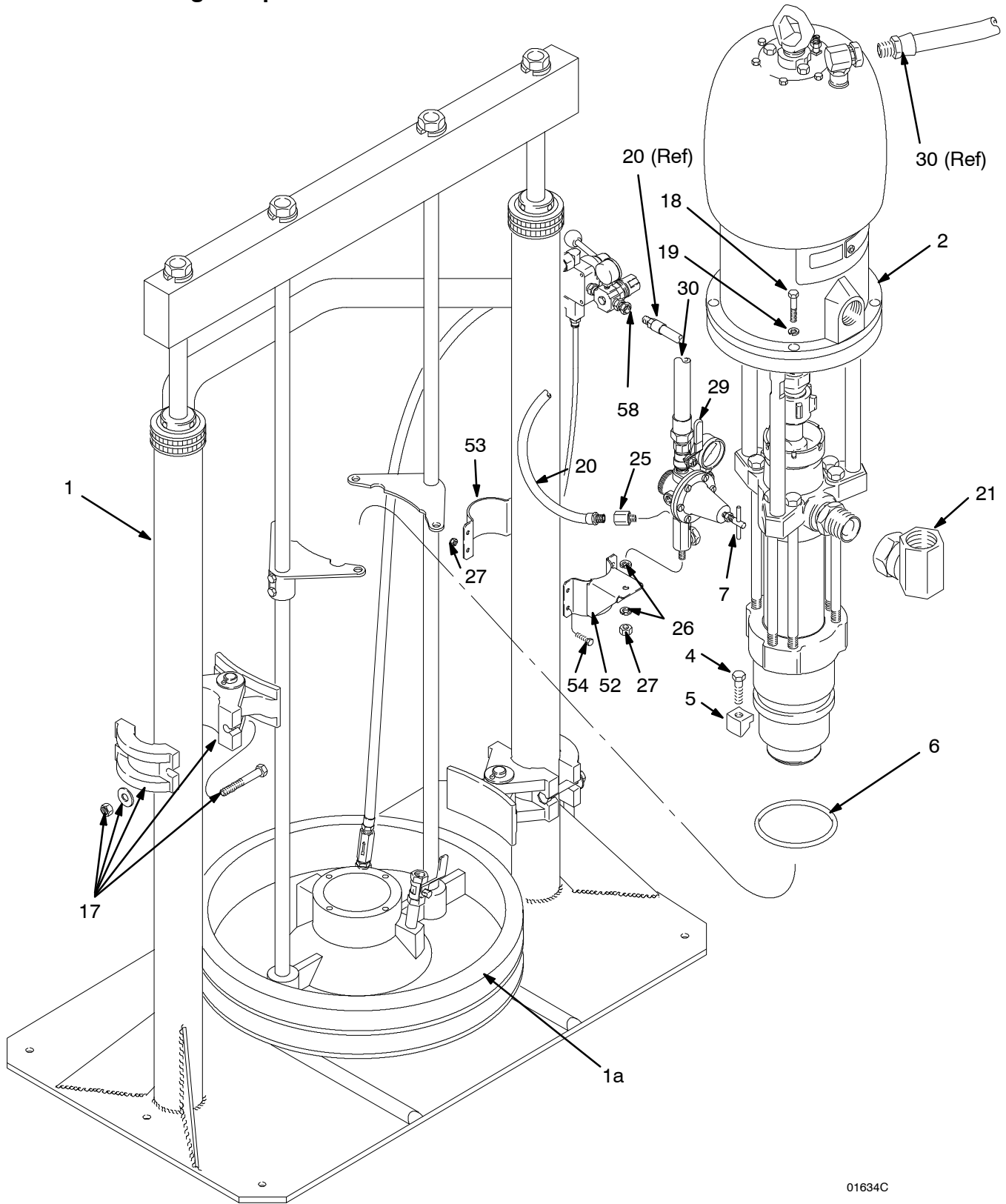

01634C

Parts

Model 234371, Series A 12:1 Ratio Bulldog Pump

Ref No.	Part No.	Description	Qty	Ref No.	Part No.	Description	Qty
1	207279	RAM, drum, 200 liter (55 gal.) See parts in 306934	1	21	109512	ADAPTER, fluid outlet, 90°; 1-1/2 npt(f) x 1-1/2 npsm(f) swivel	1
1a	248088	PLATE, ram; used in place of standard ram plate on Model 234371 only.	1	25	159840	ADAPTER, swivel, 90°; 1/4 npt(m) x 1/4 nps(f) swivel	1
2	246935	12:1 RATIO BULLDOG PUMP, (Model 234371 only) See 308149 for parts	1	26	100322	WASHER, lock	2
4	102637	SCREW, cap, hex hd; 3/8-16 unc-2a x 38 mm (1.5 in.) long	4	27	100131	NUT, hex; 3/8-16unc-2b	1
5	276025	LUG	4	29	113269	VALVE, bleed type; red handled; 1/2 npt(m x f)	1
6	109495	O-RING; fluoroelastomer	1	30	238088	HOSE, coupled; 3/4-14 npt(m x 2); 66.0 in. (1.68 m) long	1
7	238724	AIR REGULATOR See 308168 for parts	1	52	237962	BRACKET, welded	1
17	206537	CLAMP, drum (set of two)	1	53	190747	BRACKET, ram	1
18	100101	SCREW, hex hd cap; 3/8-16 x 1 in. (25.4 mm) long	4	54	100021	SCREW, cap; 1/4-20unc-2a	4
19	100133	WASHER, spring lock; 3/8 in. (9.5 mm)	4	55	102040	NUT, lock; 1/4-20unc-3b	4
20	109123	HOSE, coupled; buna-n; 1/4-18 npt (m x 2); 1/4 in. (6 mm) ID; 18.0 in. (0.46 m) long	1	58	113344	UNION, swivel; 1/2 npt(m) x 3/4 npsm(f)	1

Parts

Model 234376, Series B
Viscount II 2100 Pump

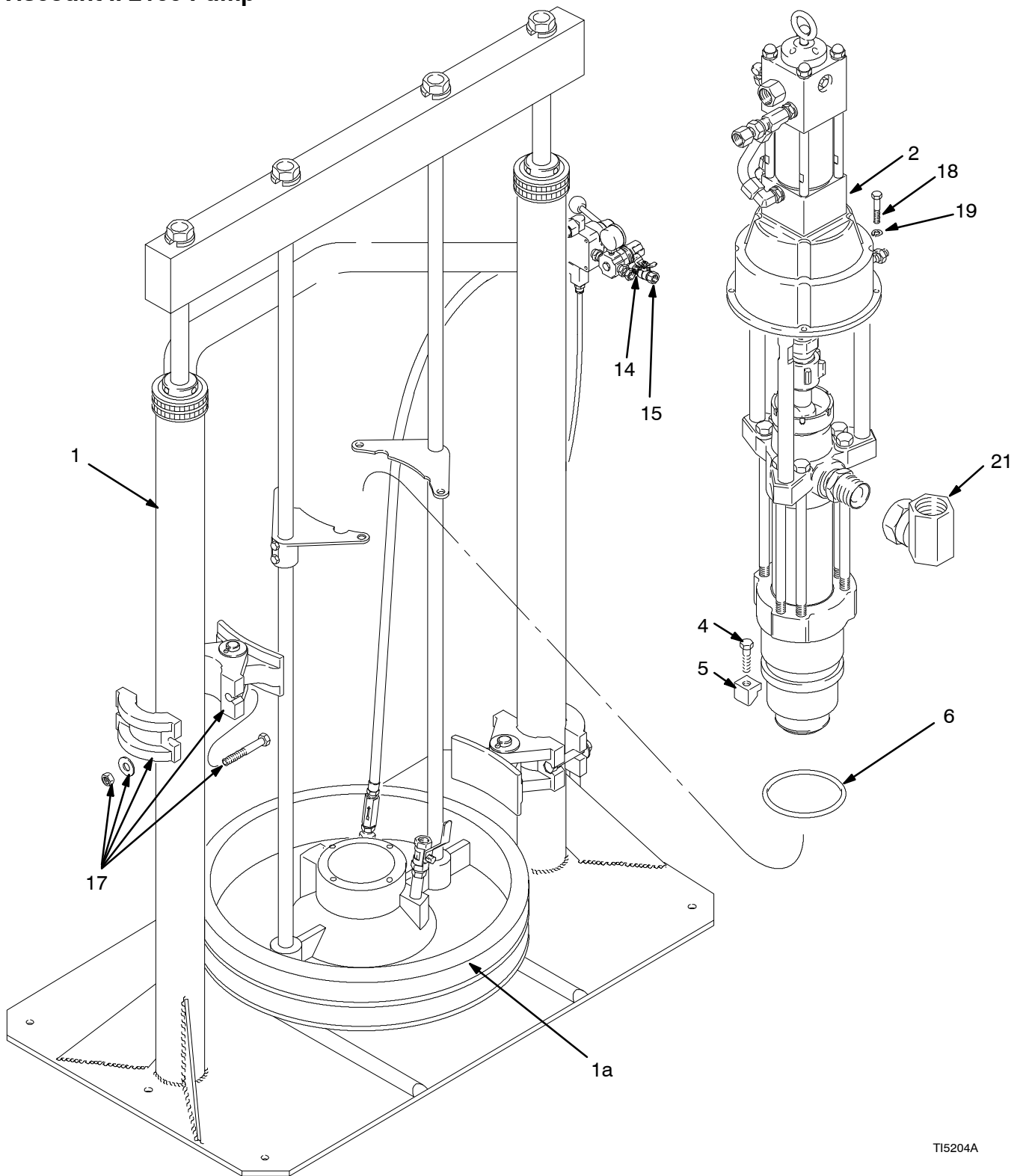

TI5204A

Parts

Model 234376, Series B Viscount II 2100 Pump

Ref No.	Part No.	Description	Qty	Ref No.	Part No.	Description	Qty
1	207279	RAM, drum, 200 liter (55 gal.) See parts in 306934	1	6	109495	O-RING; fluoroelastomer	1
1a	248088	PLATE, ram; used in place of standard ram plate.	1	14	156971	NIPPLE, short	1
2	246937	PUMP, Viscount/Checkmate See 308149 for parts	1	15	110223	VALVE, vented 2 way	1
4	102637	SCREW, cap, hex hd; 3/8-16 unc-2a x 38 mm (1.5 in.) long	4	17	206537	CLAMP, drum (set of two)	1
5	276025	LUG	4	18	100101	SCREW, hex hd cap; 3/8-16 x 1 in. (25.4 mm) long	4
				19	100133	WASHER, spring lock; 3/8 in. (9.5 mm)	4
				21	109512	ADAPTER, fluid outlet, 90°; 1-1/2 npt(f) x 1-1/2 npsm(f) swivel	1

Parts

Model 234372, Series A 24:1 Ratio King Pump

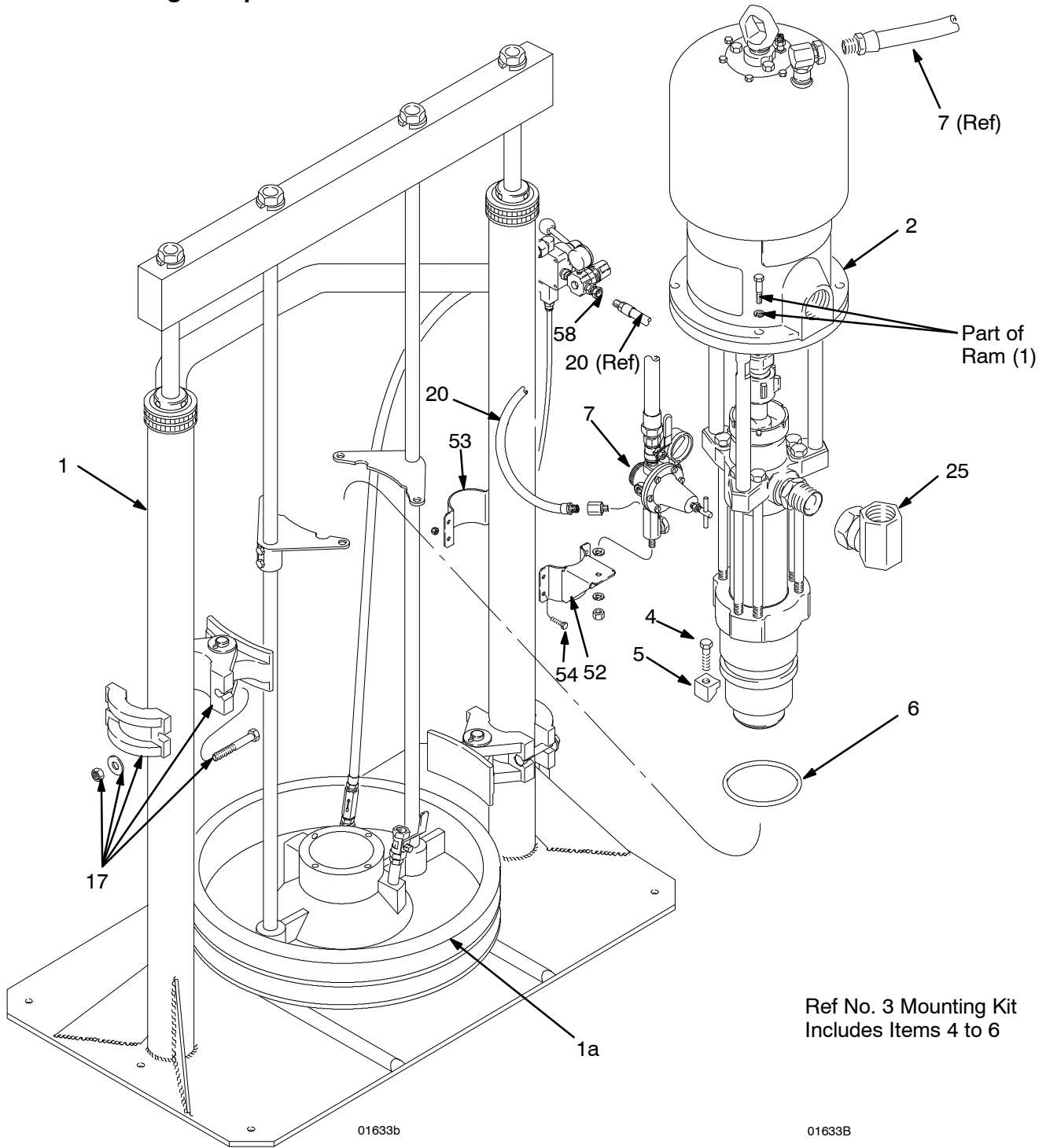

Parts

Model 234372, Series A 24:1 Ratio King Pump

Ref No.	Part No.	Description	Qty	Ref No.	Part No.	Description	Qty
1	207279	RAM, drum, 200 liter (55 gal.) See 306934 for parts	1	17	206537	CLAMP, drum (set of two)	1
1a	248088	PLATE, ram; used in place of standard ram plate on Model 234372 only.		18	223882	KIT, accessory, ram Includes items 19 to 24	1
	238929	PLATE, ram; used in place of standard ram plate on Model 235836 only.	1	19	155541	. ADAPTER, swivel, 90°; 1/4 npt(m) x 1/4 nps(f) swivel	1
2	246936	24:1 RATIO KING PUMP (Model 234372 only) See 308149 for parts	1	20	200115	. HOSE; neoprene; 1/4 in. (6 mm) ID; coupled 1/4 npt (mbe); 1.2 m (4 ft) long	1
3	222776	KIT, mounting; Includes items 4 to 6	1	24	100896	. BUSHING; 3/4 npt(m) x 1/2 npt(f)	1
4	102637	. SCREW, cap, hex hd; 3/8-16 unc-2a x 38 mm (1.5 in.) long	4	25	109512	ADAPTER, fluid outlet, 90°; 1-1/2 npt(f) x 1-1/2 npsm(f) swivel	1
5	276025	. LUG	4	52	237962	BRACKET, welded	1
6	109495	. O-RING; fluoroelastomer	1	53	190747	BRACKET, ram	1
7	238032	AIR REGULATION KIT See 308168 for parts	1	54	100021	SCREW, cap; 1/4-20 unc-2a	4
8	238088	HOSE, coupled; 3/4-14 npt(m x 2); 66 in. (1.68 m) long	1	55	102040	NUT, lock; 1/4-20 unc-3b	4
				58	156823	UNION, swivel; 1/4 npt(m) x 1/4 npsm(f)	1

Parts

Model 234373, Series A 65:1 Ratio King Pump

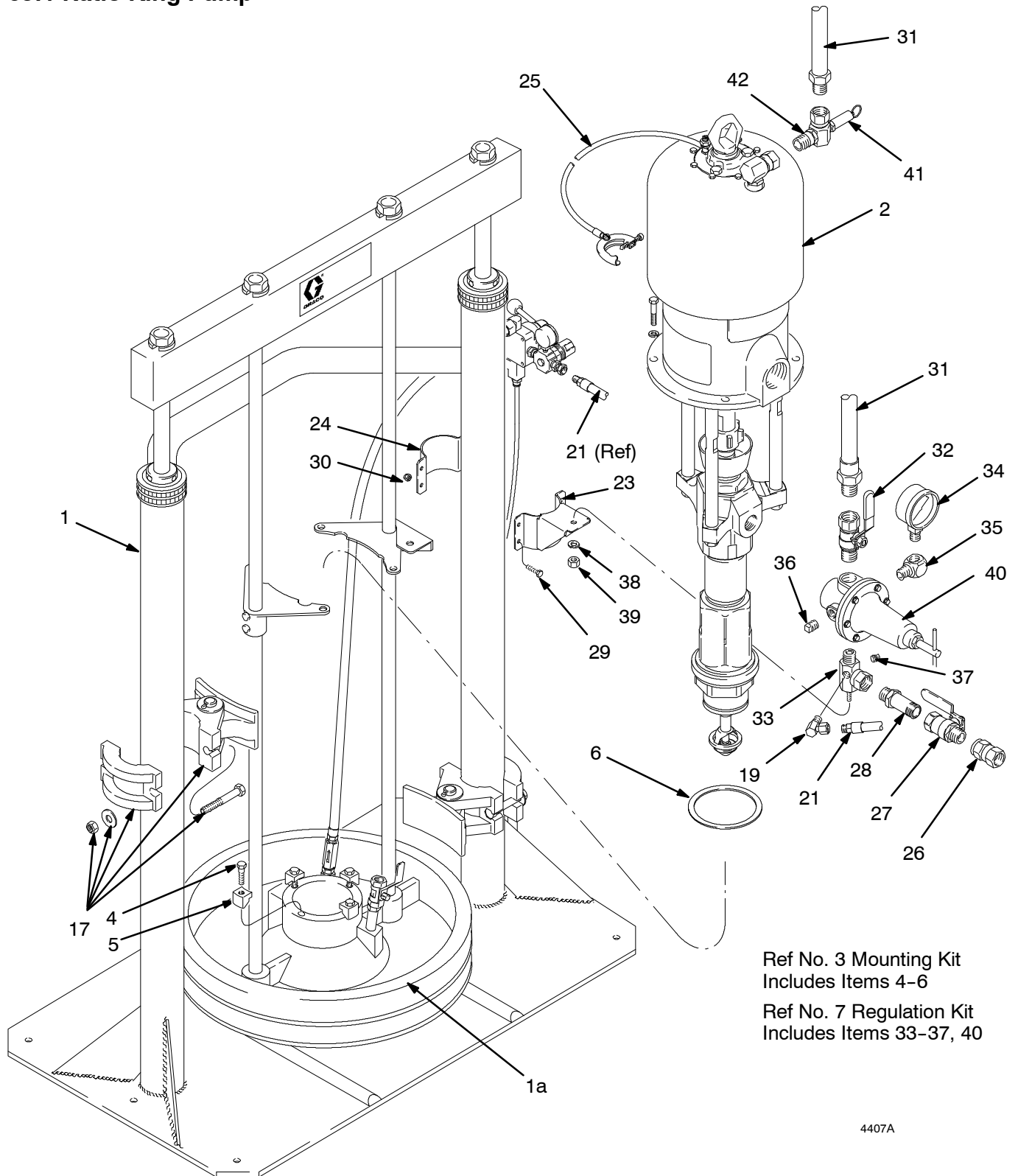

Ref No. 3 Mounting Kit
Includes Items 4-6
Ref No. 7 Regulation Kit
Includes Items 33-37, 40

4407A

Parts

Model 234373, Series A 65:1 Ratio King Pump

Ref No.	Part No.	Description	Qty	Ref No.	Part No.	Description	Qty
1	207279	RAM, drum, 200 liter (55 gal.) See 306934 for parts	1	24	190747	BRACKET	1
1a	248088	PLATE, ram; used in place of standard ram plate on Model 234373 only.	1	25	237569	GROUND WIRE	1
2	246942	65:1 RATIO KING PUMP (Model 234373 only) See 308351 for parts	1	26	156172	SWIVEL; 3/4 npt(m) x 3/4 npsm(f)	1
3	222776	KIT, mounting; Includes items 4-6	1	27	113218	AIR VALVE, bleed-type; 3/4 npt(m x f)	1
4	102637	. SCREW, cap, hex hd; 3/8-16 unc-2a x 38 mm (1.5 in.) long	4	28	157129	FITTING, nipple, pipe; 3/4 npt	1
5	276025	. LUG	4	29	100021	SCREW; 1/4-20 unc-3a; 1.25 in. (31 mm) long	4
6	109495	. O-RING; fluoroelastomer	1	30	102040	NUT, hex, locking; 1/4-20 unc-3b	4
7	238704	AIR REGULATION KIT Includes items 33-37, 40 See 308168 for parts	1	31	238088	HOSE, coupled; 3/4-14 npt(m x 2); 66 in. (1.68 m) long	1
17	206537	CLAMP, drum (set of two)	1	32	107141	BLEED VALVE; 3/4 npt(m x f)	1
19	155541	ADAPTER, swivel, 90°; 1/4 npt(m) x 1/4 npsm(f) swivel	1	33	207675	MANIFOLD, air; 3/4 npsm(f)	1
20	206994	THROAT SEAL LIQUID; 8 oz (0.5 liter); not shown	1	34	100960	GAUGE, air	1
21	109123	HOSE, air assist	1	35	100840	ELBOW, street; 90°; 1/4 npt(m x f)	1
23	237962	BRACKET	1	36	100509	PLUG, pipe, sq hd; 1/4 npt	1
				37	100403	PLUG, pipe; 1/8 npt	1
				38	100322	WASHER, lock, internal tooth; 3/8 in.	2
				39	100131	NUT, hex; 3/8-16	1
				40	207755	AIR REGULATOR See 308168 for parts	1
				41	103347	VALVE, safety; 100 psi	1
				42	192171	FITTING, union, adapter, 90°	1

Parts

Model 234374, Series A 31:1 Ratio Bulldog Pump

Ref No.	Part No.	Description	Qty	Ref No.	Part No.	Description	Qty
1	241252	RAM, drum, 200 liter (55 gal.) PVC See 306934 for parts	1	23	237962	BRACKET	1
1a	248088	PLATE, ram; used in place of standard ram plate on Model 234374 only.	1	24	190747	BRACKET	1
2	237261	31:1 RATIO BULLDOG PUMP (Model 918552 only)	1	25	237569	GROUND WIRE	1
	246940	31:1 RATIO BULLDOG PUMP See 308351 for parts	1	26	156172	SWIVEL; 3/4 npt(m) x 3/4 npsm(f)	1
3	222776	KIT, mounting; Includes items 4 to 6	1	27	113218	AIR VALVE, bleed-type; 3/4 npt(m x f)	1
4	102637	. SCREW, cap, hex hd; 3/8-16 unc-2a x 38 mm (1.5 in.) long	4	28	157129	FITTING, nipple, pipe; 3/4 npt	1
5	276025	. LUG	4	29	100021	SCREW; 1/4-20 unc-3a; 1.25 in. (31 mm) long	4
6	109495	. O-RING; fluoroelastomer	1	30	102040	NUT, hex, locking; 1/4-20 unc-3b	4
7	238704	AIR REGULATION KIT See 308168 for parts	1	31	238088	HOSE, coupled; 3/4-14 npt(m x 2); 66 in. (1.68 m) long	1
13	110300	ELBOW, street, pipe	1	32	107141	BLEED VALVE; 3/4 npt(m x f)	1
16	109123	HOSE, coupled, 18 in.	1	33	207675	MANIFOLD, air; 3/4 npsm(f)	1
17	206537	CLAMP, drum (set of two)	1	34	100960	GAUGE, air	1
19	155541	ADAPTER, swivel, 90°; 1/4 npt(m) x 1/4 npsm(f) swivel	1	35	100840	ELBOW, street; 90°; 1/4 npt(m x f)	1
20	206994	THROAT SEAL LIQUID; 8 oz (0.5 liter); not shown	1	36	100509	PLUG, pipe, sq hd; 1/4 npt	2
				37	100403	PLUG, pipe; 1/8 npt	1
				38	100322	WASHER, lock, internal tooth; 3/8 in.	2
				39	100131	NUT, hex; 3/8-16	1
				40	110318	AIR REGULATOR See 308168 for parts	1

Parts

Model 253482, Series A
41:1 Ratio Bulldog Pump

Model 253701, Series A
20:1 Ratio King Pump

Parts drawing continued on page 66
 Parts list continued on page 67

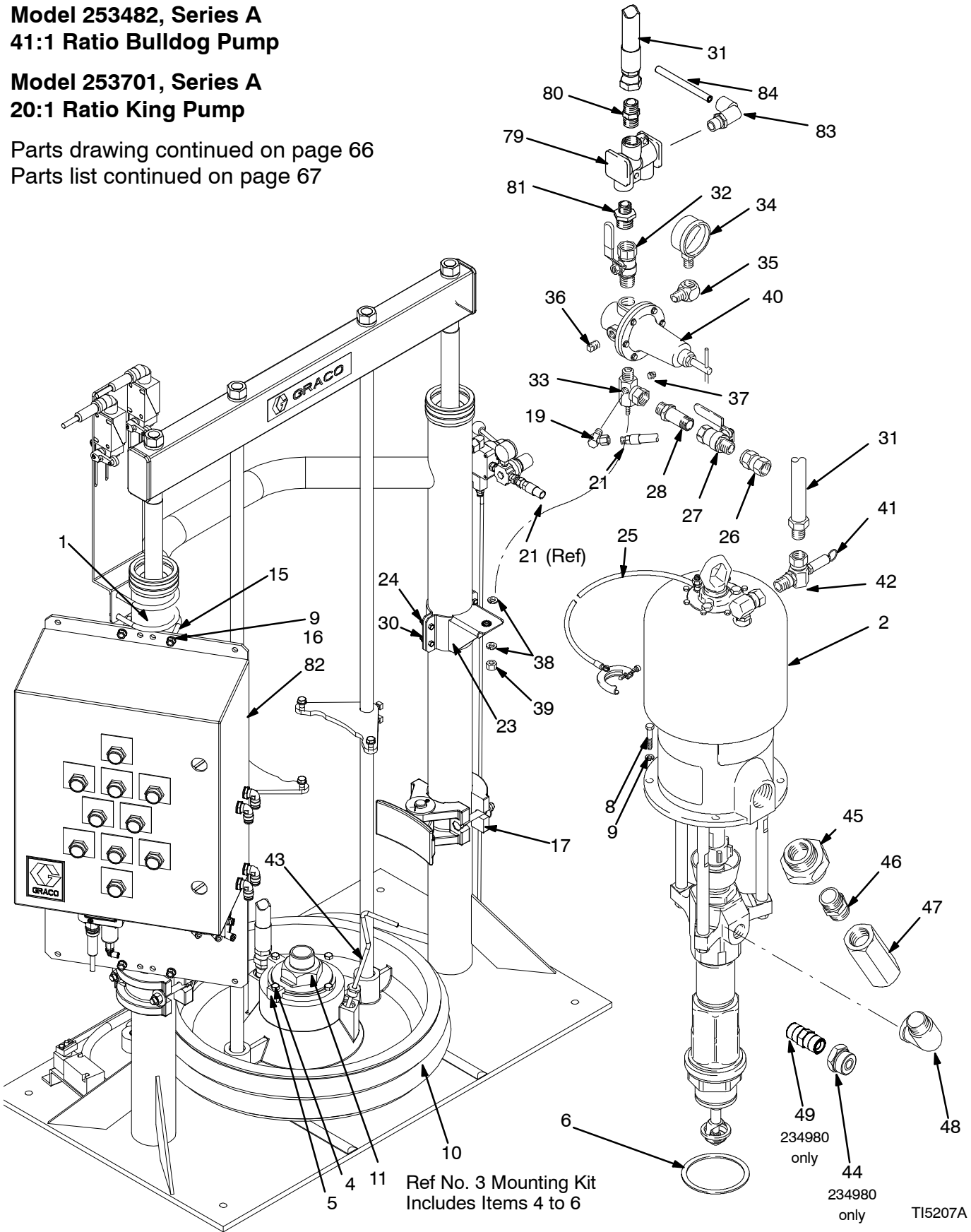

Parts

Model 253482, Series A 41:1 Ratio Bulldog Pump

Model 253701, Series A 20:1 Ratio King Pump

Parts drawing continued on page 66

Parts list continued on page 67

Ref No.	Part No.	Description	Qty	Ref No.	Part No.	Description	Qty
1	207279	RAM, drum, 200 liter (55 gal.) See 306934 for parts	1	32	107141	BLEED VALVE; 3/4 npt(m x f)	1
2	222833	20:1 RATIO KING PUMP (253701 only)	1	33*	207675	MANIFOLD, air; 3/4 npsm(f)	1
	237634	41:1 RATIO BULLDOG PUMP (253482 only)	1	34*	100960	GAUGE, air	1
3	222776	KIT, mounting; Includes items 4 to 6	1	35*	100840	ELBOW, street; 90°; 1/4 npt(m x f)	1
4	102637	. SCREW, cap, hex hd; 3/8-16 unc-2a x 38 mm (1.5 in.) long	4	36*	100509	PLUG, pipe, sq hd; 1/4 npt	1
5	276025	. LUG	4	37*	100403	PLUG, pipe; 1/8 npt	1
6	109495	. O-RING; fluoroelastomer	1	38	100322	WASHER, lock, internal tooth; 3/8 in.	2
7	238704	AIR REGULATION KIT See 308168 for parts	1	39	100131	NUT, hex; 3/8-16	1
8	100101	SCREW	4	40*	207755	AIR REGULATOR See 308168 for parts	1
9	100133	WASHER	4	41	103347	VALVE, safety, 75 psi (253482 only)	1
10	C56135	PLATE, 55gal, PTFE	1	42	192171	FITTING, union, adapter, 90° (253482 only)	1
11	190737	CYLINDER, intake (253482 only)	1	43	237771	HANDLE, bleed	1
17	206537	CLAMP, drum (set of two)	1	44	C19661	FITTING, nipple, reducing; 1-1/4 in. npt(m) by 1 in. npt(m)	1
19	155541	ADAPTER, swivel, 90°; 1/4 npt(m) x 1/4 npsm(f) swivel	1	45	521975	FITTING, union, pipe; 1-1/4 in. npt	1
20	206994	THROAT SEAL LIQUID; 8 oz (0.5 liter); not shown	1	46	C20490	FITTING, nipple, hex; 1-1/4 in. npt	1
21	109123	HOSE, air assist	1	47	521850	VALVE, check	1
23	237962	BRACKET	1	48	C38324	FITTING, elbow, street, 90°; 1-1/4 in. npt(m x f)	1
24	190747	BRACKET	1	49	175013	NIPPLE, pipe; 3/4-14 npt(m) (253482 only)	1
25	237569	GROUND WIRE	1		C20892	ADAPTER, hex hd (253701 only)	1
26	156172	SWIVEL; 3/4 npt(m) x 3/4 npsm(f)	1	79	104632	VALVE, piloted	1
27	113218	AIR VALVE, bleed-type; 3/4 npt(m x f)	1	80	113344	SWIVEL, union assy.	1
28	157129	FITTING, nipple, pipe; 3/4 npt	1	81	157191	FITTING, adapter (1/2npt x 3/4npt)	1
29	100021	SCREW; 1/4-20 unc-3a; 1.25 in. (31 mm) long	4	83	128863	FITTING, elbow, air line	1
31	C12034	HOSE, coupled; 3/4-14 npt(m x 2); 66 in. (1.68 m) long	1	84	C12509	TUBING, air,	50 ft

* Included in Repair Kit 238704.

Parts

Model 253482, Series A (continued from page 64)
41:1 Ratio Bulldog Pump

Model 253701, Series A (continued from page 64)
20:1 Ratio King Pump

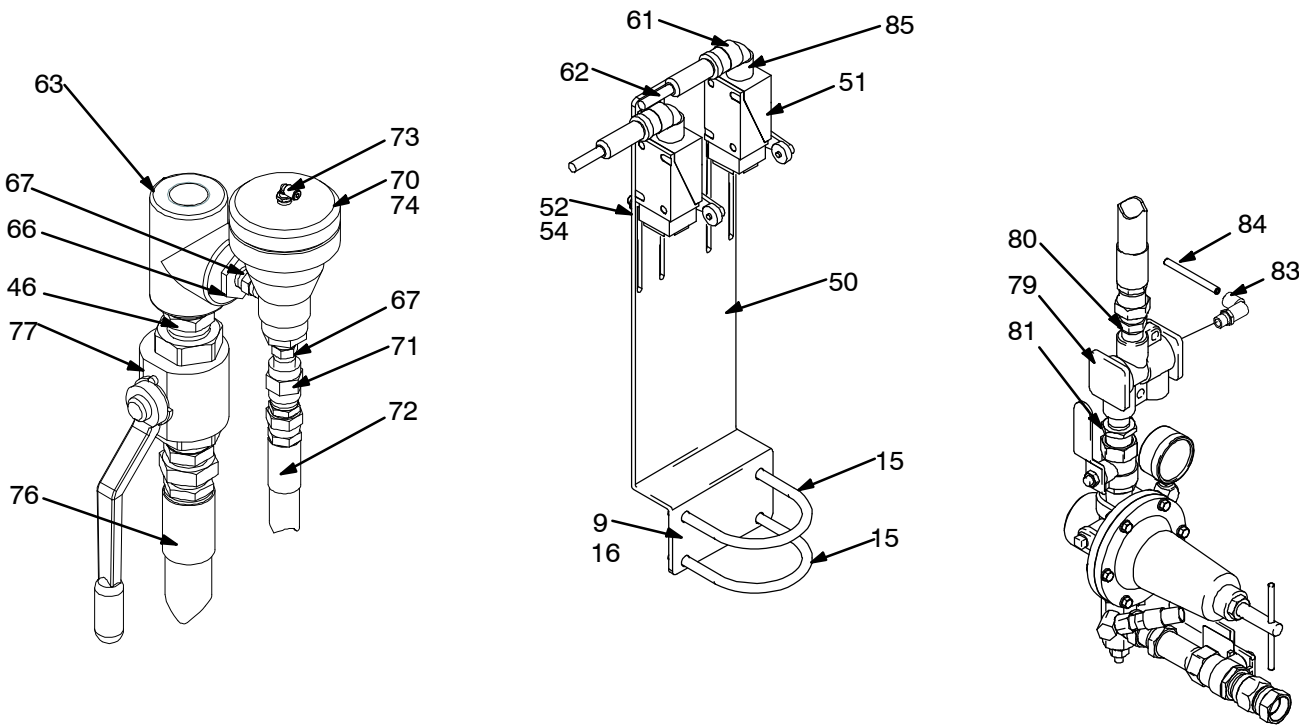
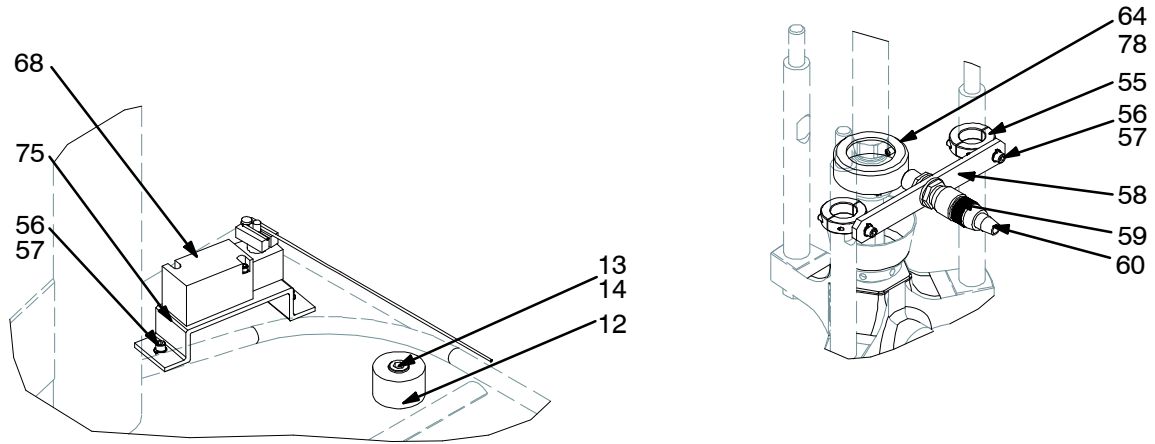

Parts

Model 253482, Series A (continued from page 65) 41:1 Ratio Bulldog Pump

Model 253701, Series A (continued from page 65) 20:1 Ratio King Pump

Ref No.	Part No.	Description	Qty	Ref No.	Part No.	Description	Qty
12	C32467	STOP, drum	2	67	C20485	FITTING, nipple, hex	2
13	C38185	WASHER, lock	2	68	195356	KIT, accessory	1
14	C19853	SCREW, cap, socket HD	2	69	C19871	SCREW, machined	2
15	515998	BOLT, U, 3 1/2 x 3/8-16	4	70	918537	APPLICATOR, ball seat, 1/2 port, 60:1	1
16	100307	NUT, hex	8	71	158556	COUPLING, hex pipe	1
50	15H662	BRACKET, limit switch	1	72	234558	HOSE, coupled	1
51	C07560	SWITCH, limit w/ arm	2	73	C19391	FITTING, elbow	2
52	C19197	WASHER, plain	8	74	C19254	PLUG, pipe, flush 1/4 in.	1
54	551787	SCREW, cap, socket head	8	75	15H686	BRACKET, limit switch	1
55	617337	COLLAR clamp	2	76	234428	HOSE, coupled	1
56	C19209	WASHER, lock	4	77	118854	VALVE, ball, high pressure	1
57	C19800	SCREW, cap, socket HD	4	78	C19363	SCREW	1
58	617338	BRACKET, mounting	1	79	104632	VALVE, piloted	1
59	517455	SWITCH, 18mm proximity	1	80	113344	SWIVEL, union assy.	1
60	C56572	CABLE	1	81	157191	FITTING, adapter (1/2npt x 3/4npt)	1
61	C07431	CONNECTOR, sealed (253482 only)	2	82	243255	KIT, accessory PLC	1
62	C07435	CONNECTOR, sealed (253482 only)	2	83	128863	FITTING, elbow, air line	2
63	C19491	FITTING, tee, 1-1/4 npt(f)	1	84	C12509	TUBING, air,	50 ft
64	196510	HOUSING, coupling nut (253701 only)	1	85	C20175	LOCKNUT, conduit	2
65	119417	SCREW, set, allen, 1/4-20 x 5/8	1				
66	C19660	FITTING, 1-1/4 x 1/2	1				

Parts

243255, PLC Interface Accessory Kit

Ref No.	Part No.	Description	Qty	Ref No.	Part No.	Description	Qty
201	195330	PLATE, mounting	1	211	C07434	CORD, 5-pin; 6 ft long	1
202	C55568	SWITCH, pressure; 1/4 in. npt	1	212	C19407	FITTING, tube; 1/4T x 1/8P	2
203	115440	VALVE, assembly	1	213	103219	PLUG, pipe; 1/8 npt	1
204	128863	ELBOW, male	3	214	C19391	ELBOW, 90 degree, tube; 1/4P x 1/4T	1
205	111714	SCREW, S.H.C.; CS PL #4-40x 5/8	4	215	C19264	PLUG, pipe; 1/4 npt	2
206	103739	WASHER, lock; CS PL #4	4	216	C20536	CABLE, 2 cond.	8 ft
207	102313	SCREW, S.H.C.; CS PL #4-20x1.75L	2	217	195320	PANEL, junction box; see page 52	1
208	101345	NUT, hex; CS PL 1/4-20	2	218	C07435	CONNECTOR, sealed (not shown)	3
209	100016	WASHER, lock; CS PL 1/4	2	219	C12509	TUBE; 1/4 in.; nylon	50 ft
210	517449	MUFFLER	2				

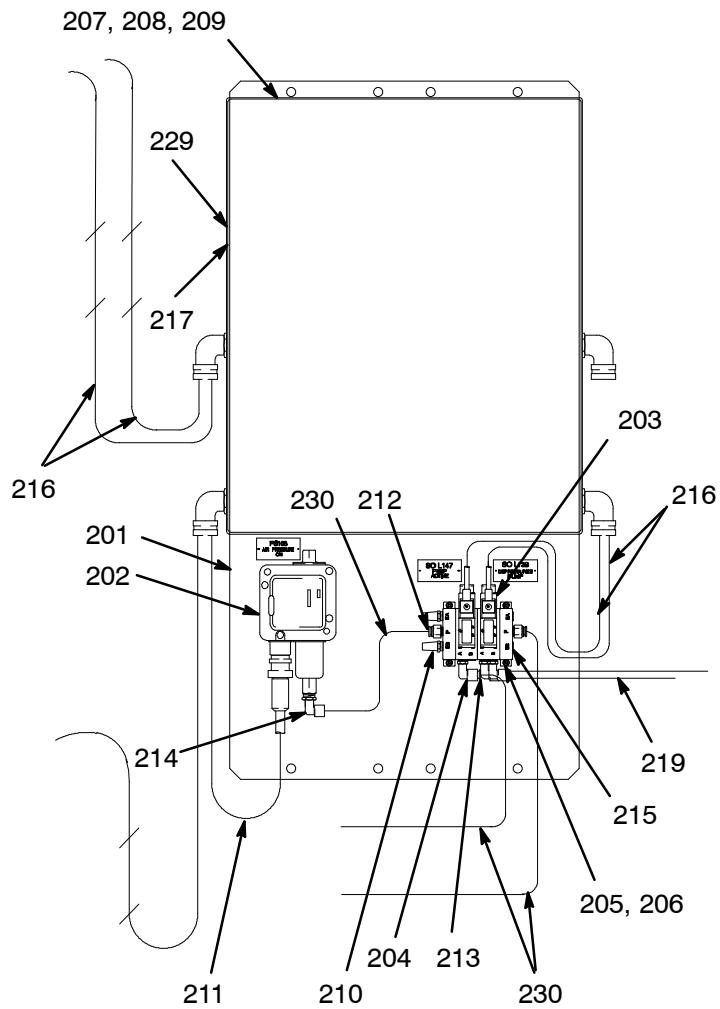

T10196

Parts

Part No. 195320, PLC Interface Panel

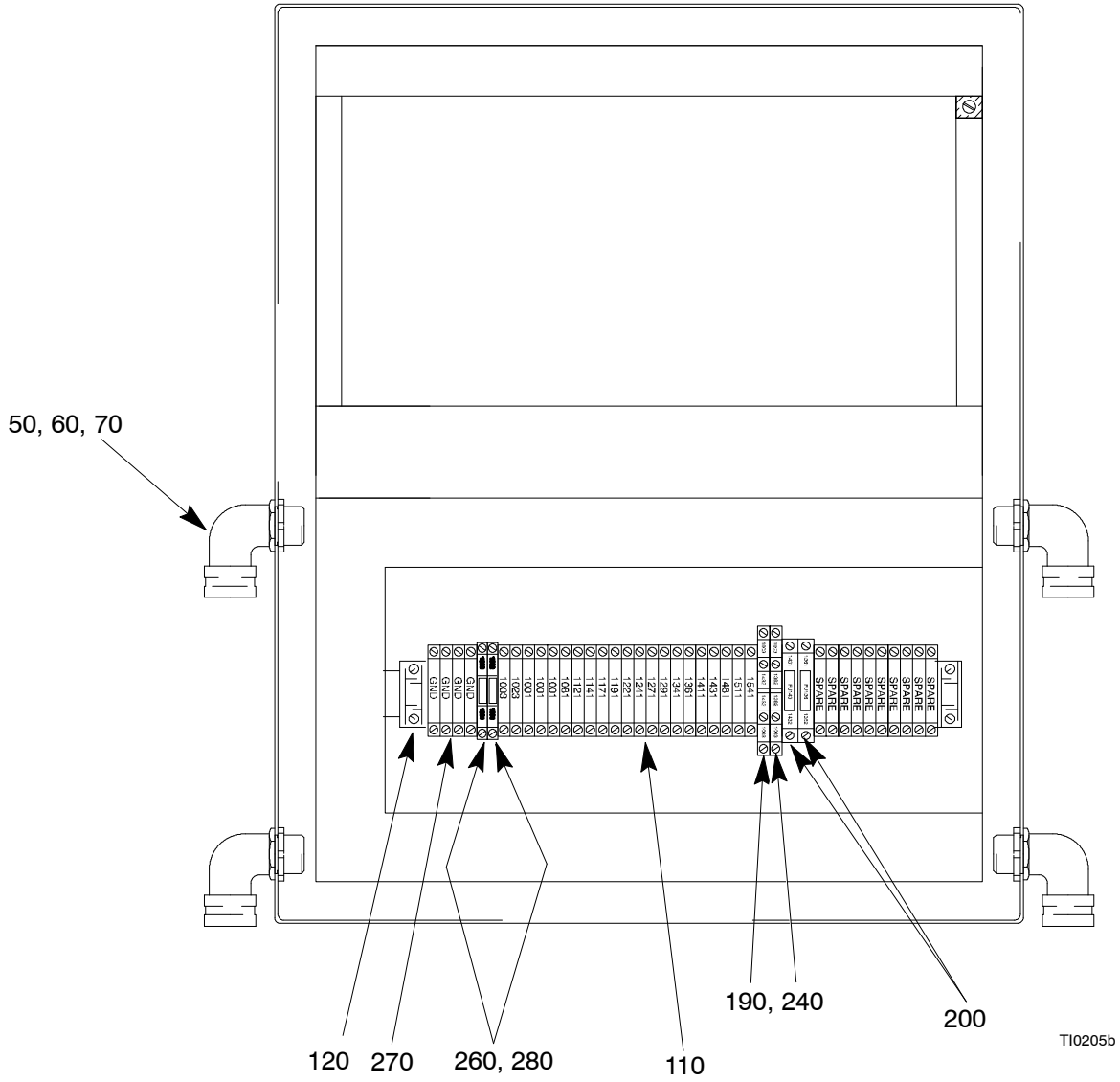

Parts

Part No. 195320, PLC Interface Panel

Ref No.	Symbol	Description	Remark	U.L. File No.	Qty
290		P-N 90 DEG. CORD GRIP DB-1090			4
280		A-B PB 800T-XD2			1
270	PB	A-B PB 800T FX 9A1			1
260	SS	A-B SS 800T-H2A			1
250		BARRIER ENTRELEC 02910.422.10			1
240					
230	FU	BUSS FUSS GDC-250 MA 5 X 20 mm			2
220		GND ENTRELEC 0290.019.05		E160646	4
210	DISC	ENTRELEC 0290.041.03	K5100, 102	E40735	2
200	FU	ENTRELEC FUSE BLOCK 0115.662.22	FU136, 143	E40735	2
190	SUP	A-B SUPPRESSOR 1492-WD4SS	SUP136, 144	E40735	2
180	PB	A-B PB #800T-A2D1 (BLACK)	PB119, 122		2
170	PB	A-B PB #800T-A2D1 (GREEN)	PB124		1
160	LT	A-B LIGHT WHITE #800T-PT16W	LT148	E14840-NKCR	1
150	LT	A-B LIGHT BLUE #800T-PT16B	LT110	E14840-NKCR	1
140	LT	A-B LIGHT AMBER #800T-PT16A	LT141	E14840-NKCR	1
130	LT	A-B LIGHT GREEN #800T-PT16G	LT134, 106	E14840-NKCR	2
120		A-B JUMPER 0291.103.24			AR
110		TERMINAL ENTRELEC 0290.011.25		E40735	31
70		T & B SEAL RING 5262			8
60		T & B LOCKNUT 141			8
50		P-N 90 DEG. CORD GRIP DB-890			4

Parts

Model 234377, Series A 19:1 Ratio Senator Pump

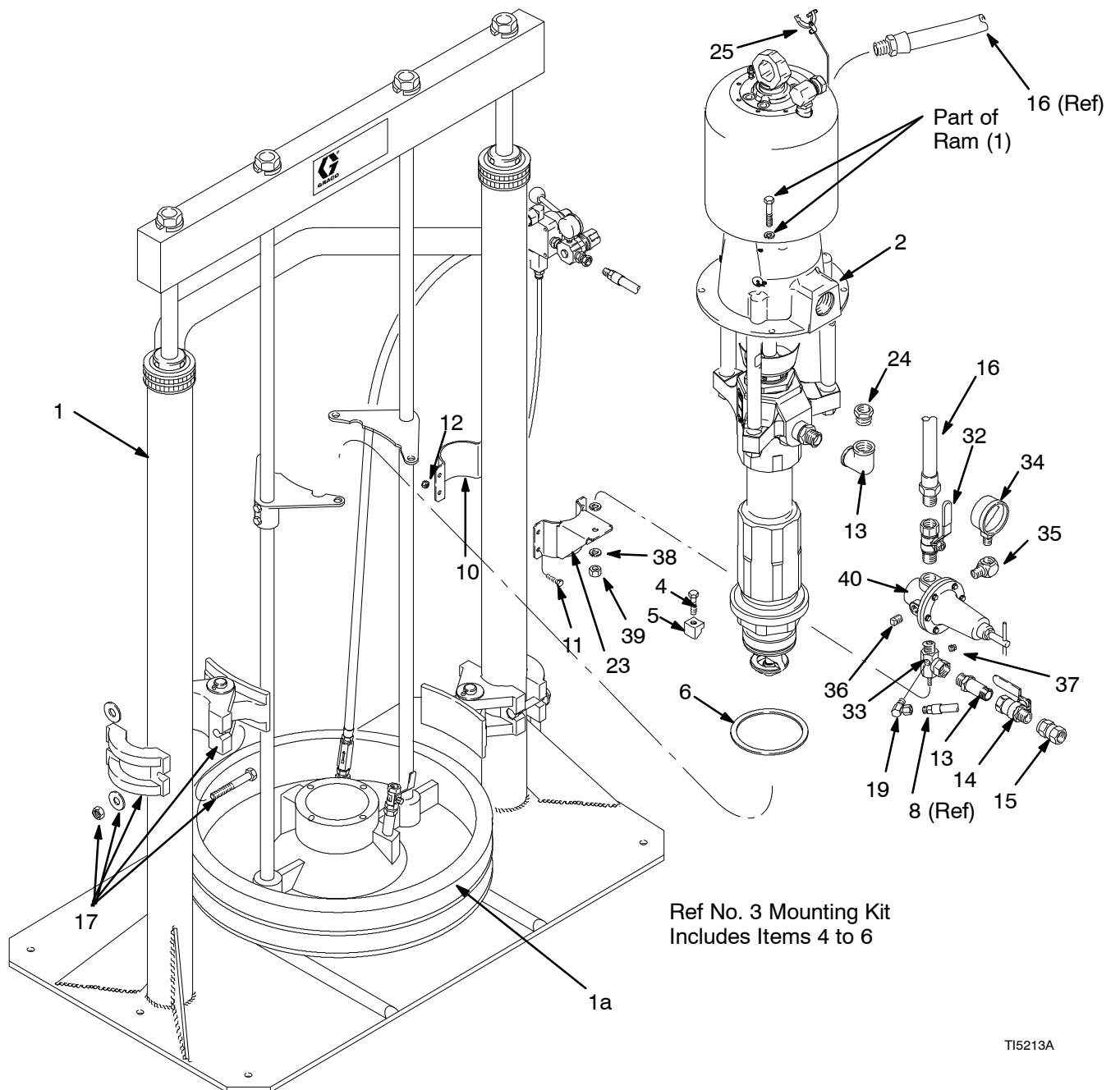

TI5213A

Parts

Model 234377, Series A 19:1 Ratio Senator Pump

Ref No.	Part No.	Description	Qty	Ref No.	Part No.	Description	Qty
1	241252	RAM, drum, 200 liter (55 gal.) PVC See 306934 for parts	1	23	237962	BRACKET	1
1a	248088	PLATE, ram; used in place of standard ram plate	1	24	190747	BRACKET	1
2	246941	19:1 RATIO Senator PUMP See 308351 for parts	1	25	237569	GROUND WIRE	1
3	222776	KIT, mounting; Includes items 4 to 6	1	26	156172	SWIVEL; 3/4 npt(m) x 3/4 npsm(f)	1
4	102637	. SCREW, cap, hex hd; 3/8-16 unc-2a x 38 mm (1.5 in.) long	4	27	113218	AIR VALVE, bleed-type; 3/4 npt(m x f)	1
5	276025	. LUG	4	28	157129	FITTING, nipple, pipe; 3/4 npt	1
6	109495	. O-RING; fluoroelastomer	1	29	100021	SCREW; 1/4-20 unc-3a; 1.25 in. (31 mm) long	4
7	238704	AIR REGULATION KIT See 308168 for parts	1	30	102040	NUT, hex, locking; 1/4-20 unc-3b	4
13	110300	ELBOW, street, pipe	1	31	238088	HOSE, coupled; 3/4-14 npt(m x 2); 66 in. (1.68 m) long	1
16	109123	HOSE, coupled, 18 in.	1	32	107141	BLEED VALVE; 3/4 npt(m x f)	1
17	206537	CLAMP, drum (set of two)	1	33	207675	MANIFOLD, air; 3/4 npsm(f)	1
19	155541	ADAPTER, swivel, 90°; 1/4 npt(m) x 1/4 npsm(f) swivel	1	34	100960	GAUGE, air	1
20	206994	THROAT SEAL LIQUID; 8 oz (0.5 liter); not shown	1	35	100840	ELBOW, street; 90°; 1/4 npt(m x f)	1
				36	100509	PLUG, pipe, sq hd; 1/4 npt	2
				37	100403	PLUG, pipe; 1/8 npt	1
				38	100322	WASHER, lock, internal tooth; 3/8 in.	2
				39	100131	NUT, hex; 3/8-16	1
				40	207755	AIR REGULATOR See 308168 for parts	1

Parts

Model 234378, Series B
Viscount II 800 Pump

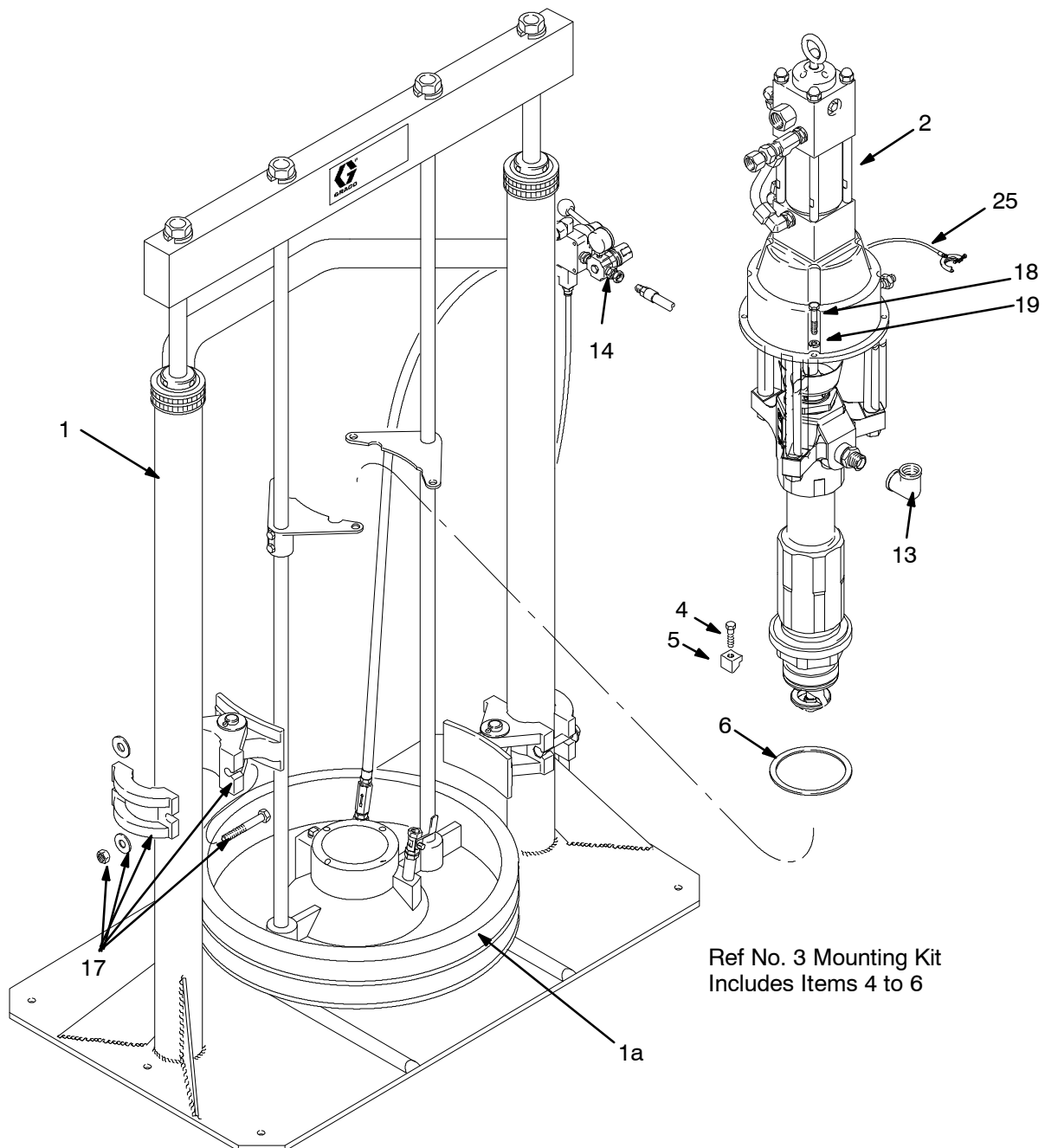

Ref No. 3 Mounting Kit
Includes Items 4 to 6

Parts

Model 234378, Series B Viscount II 800 Pump

Ref No.	Part No.	Description	Qty	Ref No.	Part No.	Description	Qty
1	207279	RAM, drum, 200 liter (55 gal.) See 306934 for parts	1	6	109495	. O-RING; fluoroelastomer	1
1a	248088	PLATE, ram; used in place of standard ram plate	1	13	110300	ELBOW, street, pipe	1
2	246938	PUMP, Viscount/Checkmate	1	14	156971	NIPPLE, short	1
3	222776	KIT, mounting; Includes items 4 to 6	1	17	206537	CLAMP, drum (set of two)	1
4	102637	. SCREW, cap, hex hd; 3/8-16 unc-2a x 38 mm (1.5 in.) long	4	18	100101	SCREW, hex hd cap; 3/8-16 x 1 in. (25.4 mm) long	4
5	276025	. LUG	4	19	100133	WASHER, spring lock; 3/8 in. (9.5 mm)	4
				20	206994	THROAT SEAL LIQUID; 8 oz (0.5 liter); not shown	1
				25	237569	GROUND WIRE	1

Parts

224829 Ram Mounting Kit, used with 23:1 Ratio Monark Pump, Model 222782

NOTE: Parts included in Mounting Kit 224829 are listed on page 59. Kits 223881, 223815, and 206537 must also be ordered to create the assembly pictured below. See page 10 for further information.

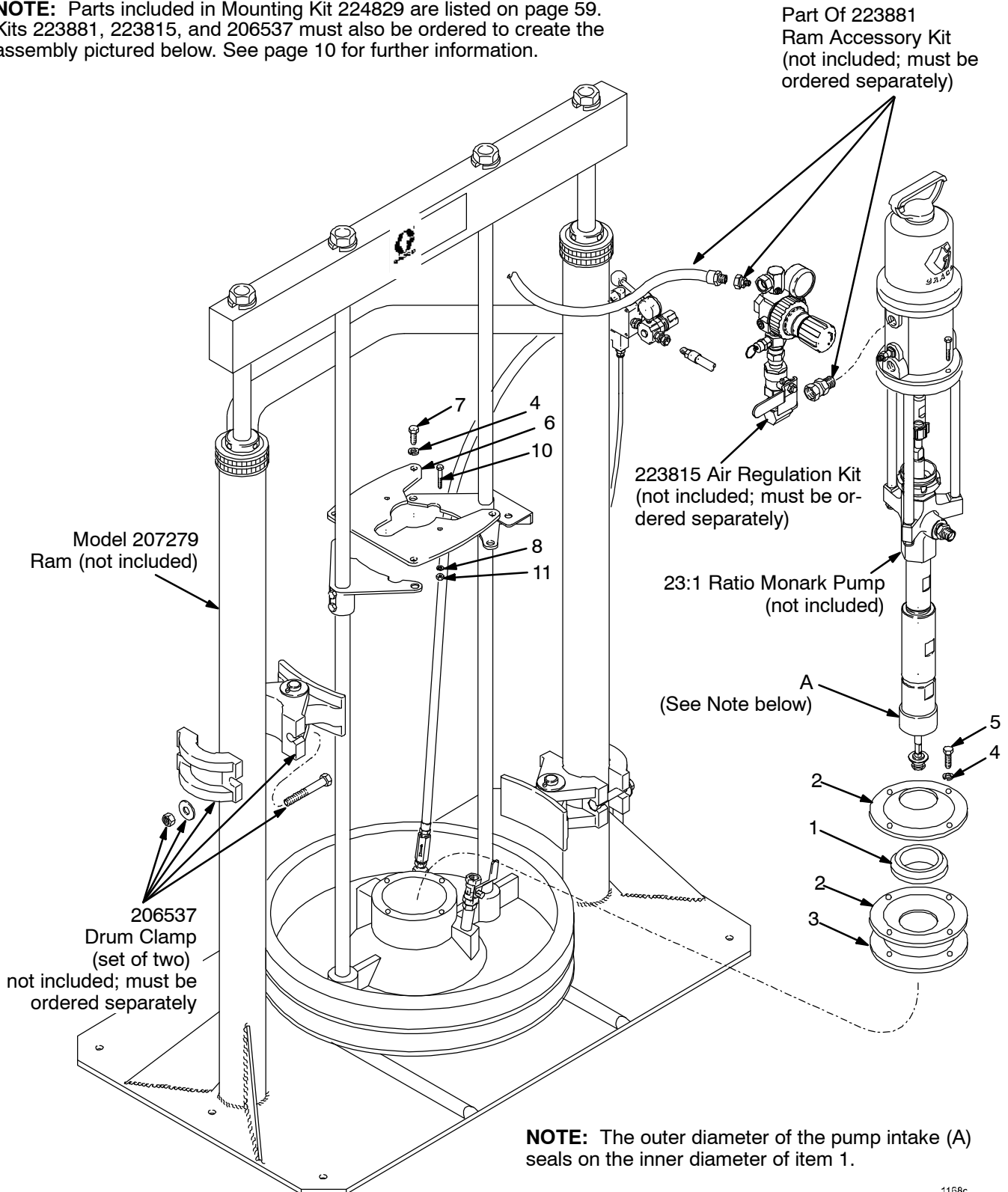

1168c

Parts

224829 Ram Mounting Kit, used with 23:1 Ratio Monark Pump, Model 222782

Ref No.	Part No.	Description	Qty	Ref No.	Part No.	Description	Qty
1	161452	SEAL, ram plate	1	9**	100270	CAPSCREW, hex hd; 1/4-20 x 5/8 in. (16 mm)	2
2	162789	PLATE, seal	2				
3	162788	GASKET; cork	1	10*	15B588	CAPSCREW, hex hd; 1/4-20 x 1-3/4 in. (45 mm)	2
4	100133	LOCKWASHER; 3/8 in. (9.5 mm)	8				
5	100004	CAPSCREW, hex hd; 3/8-16 x 1-1/4 in. (31 mm) long	4	11*	102025	NUT, hex; 1/4-20	2
6	184140	PLATE, mounting, pump	1	*	Used on Monark pumps only.		
7	100101	CAPSCREW, hex hd; 3/8-16 unc-2a x 1 in. (25 mm) long	4	**	Used on President pumps only.		
8	100016	LOCKWASHER, spring; 1/4 in. (6.3 mm)	2				

Parts

224829 Ram Mounting Kit, used with 46:1 Ratio President Pump, Model 222783

NOTE: Parts included in Mounting Kit 224829 are listed on page 61. Kits 223881, 223815, and 206537 must also be ordered to create the assembly pictured below. See page 10 for further information.

Ram 207279 includes pump mounting plate 162225. Replace Mounting Plate 162225 with item 6 (Mounting Plate 184140) when you mount this pump.

Part of 223881
Ram Accessory Kit
(not included; must be
ordered separately)

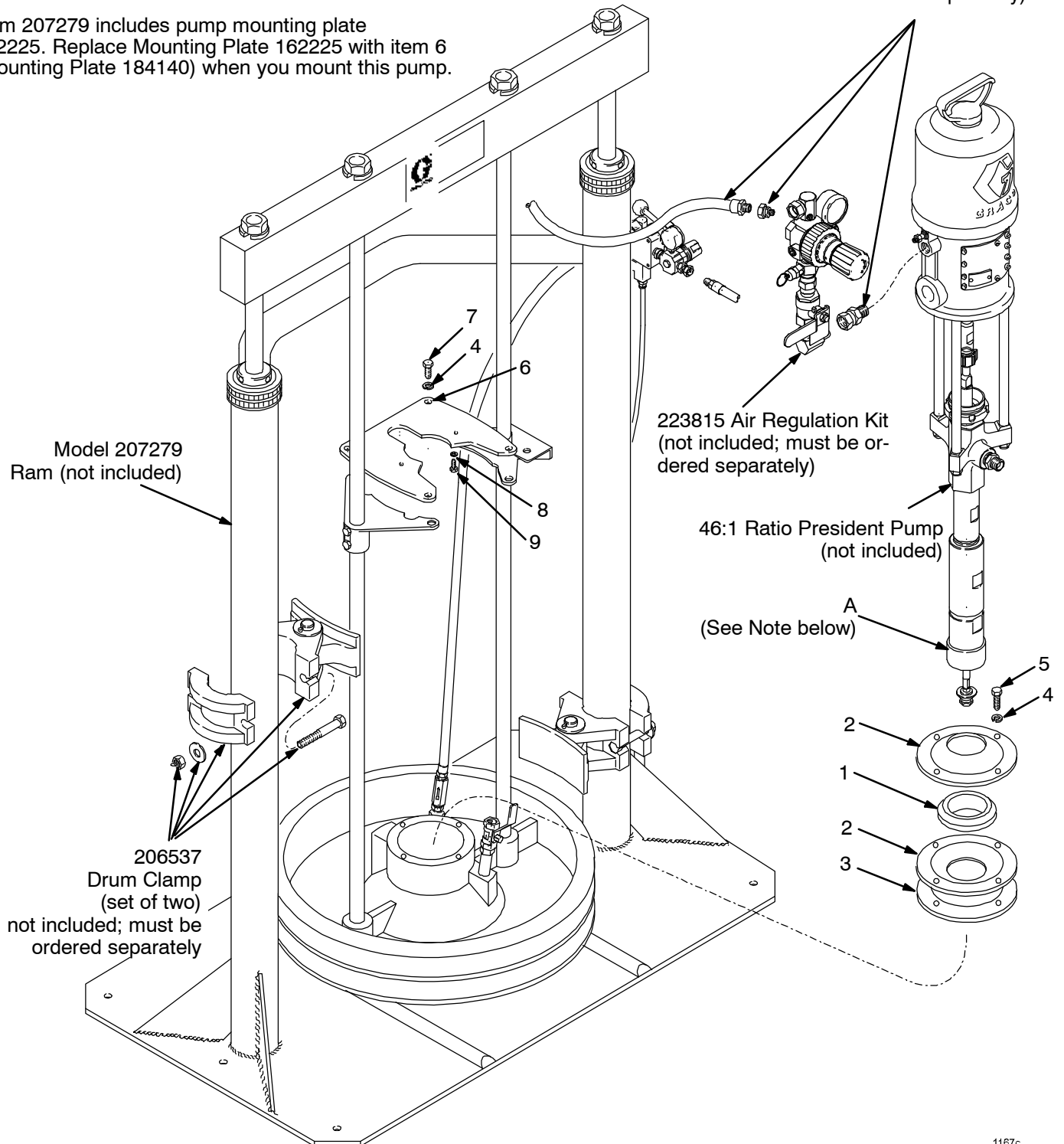

NOTE: The outer diameter of the pump intake (A) seals on the inner diameter of item 1.

1167c

Parts

224829 Ram Mounting Kit, used with 46:1 Ratio President Pump, Model 222783

Ref No.	Part No.	Description	Qty	Ref No.	Part No.	Description	Qty
1	161452	SEAL, ram plate	1			1/4 in. (6.3 mm)	2
2	162789	PLATE, seal	2	9**	100270	CAPSCREW, hex hd; 1/4-20 x 5/8 in. (16 mm)	2
3	162788	GASKET; cork	1				
4	100133	LOCKWASHER; 3/8 in. (9.5 mm)	8	10*	15B588	CAPSCREW, hex hd; 1/4-20 x 1-3/4 in. (45 mm)	2
5	100004	CAPSCREW, hex hd; 3/8-16 x 1-1/4 in. (31 mm) long	4	11*	102025	NUT, hex; 1/4-20	2
6	184140	PLATE, mounting, pump	1				
7	100101	CAPSCREW, hex hd; 3/8-16 unc-2a x 1 in. (25 mm) long	4				
8	100016	LOCKWASHER, spring;					

* Used on Monark pumps only.

** Used on President pumps only.

Dimensions

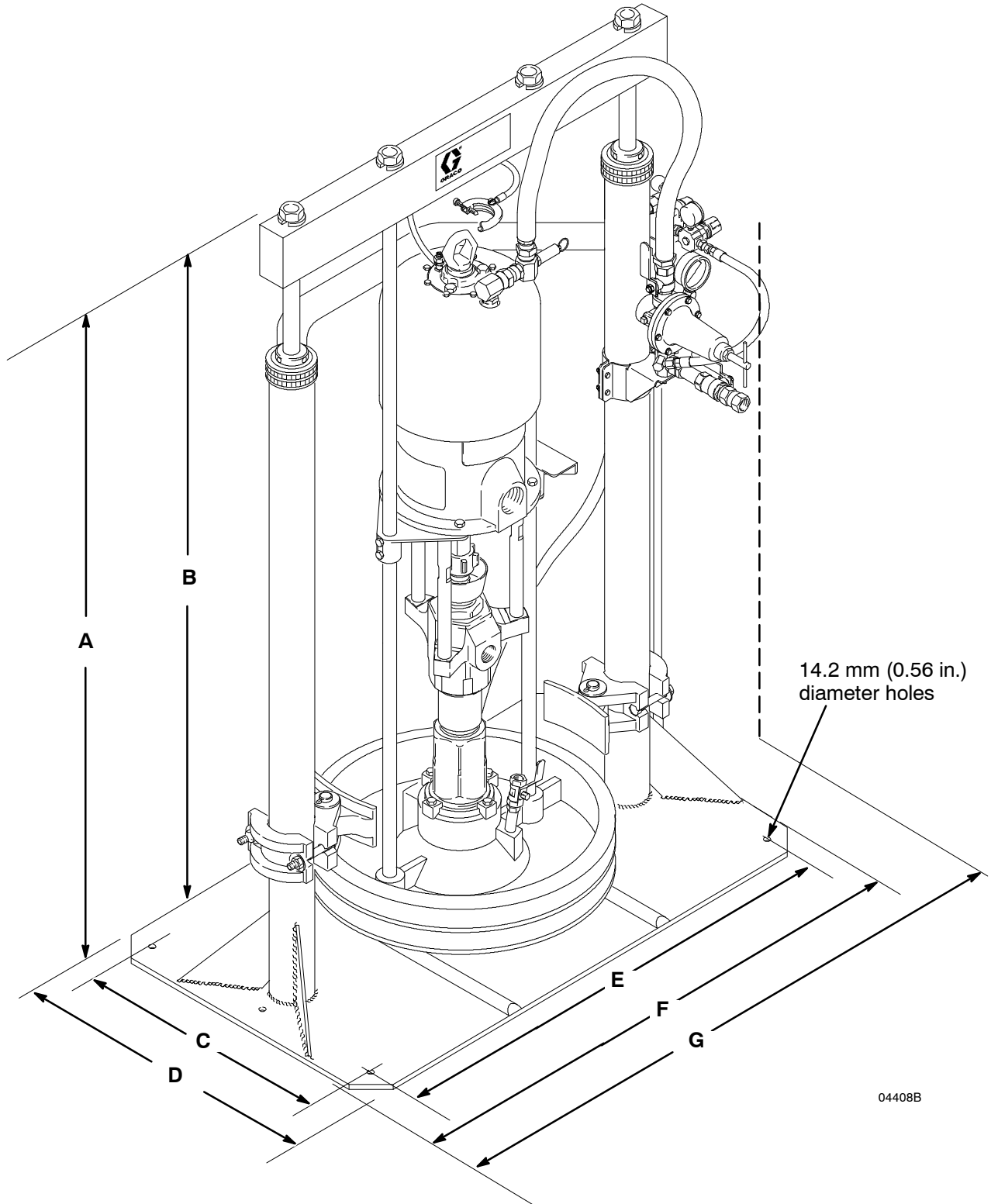

04408B

Pump Model	A (raised)	B (lowered)	C	D	E	F	G
All	2663 mm (104.8 in.)	1707 mm (67.2 in.)	533 mm (21 in.)	635 mm (25 in.)	965 mm (38 in.)	1067 mm (42 in.)	1111 mm (43.74 in.)

Technical Data

Model No.	Air Motor	Air Pressure of Sound Tests (25 cycles/min)	* Sound Pressure Level	** Sound Power Level
223816 234121 247156	Monark®	10 bar, 1 MPa (150 psi)	96 dBa	112 dBa
223817 253018 234369 234120 247155	President®	10 bar, 1 MPa (150 psi)	98 dBa	113 dBa
257589	FireBall 425 Pump	10 bar, 1 MPa (150 psi)	98 dBa	113 dBa
570114	Check-Mate	7 bar, 0.7 MPa (100 psi)	---	---
965572	Check-Mate	7 bar, 0.7 MPa (100 psi)	---	---
234377	Senator®	7 bar, 0.7 MPa (100 psi)	93 dBa	108 dBa
234374	Bulldog®	7 bar, 0.7 MPa (100 psi)	94 dBa	109 dBa
234371	Bulldog®	7 bar, 0.7 MPa (100 psi)	94 dBa	109 dBa
234373	King™	6.3 bar, 0.63 MPa (90 psi)	98 dBa	113 dBa
234372 253701	King™	6.3 bar, 0.63 MPa (90 psi)	98 dBa	113 dBa
253482	Bulldog™	7 bar, 0.7 MPa (100 psi)	94 dBa	109 dBa

* Sound pressure level was measured in accordance with Cagi Pneurop, 1969.

** Sound power level was measured in accordance with ISO 3744, 1981.

Technical Data

Maximum air input pressure (ram) 10 bar, 1.0 MPa (150 psi)
Maximum fluid working pressure and air input pressure (pump) See page 4.
Wetted parts (fluid outlet fittings) zinc or cadmium-plated carbon steel
Wetted parts (pump) See separate pump instruction manual.
Mobilux® is a registered trademark of the Mobile Oil Corporation.

Graco Standard Warranty

Graco warrants all equipment manufactured by Graco and bearing its name to be free from defects in material and workmanship on the date of sale to the original purchaser for use. With the exception of any special, extended, or limited warranty published by Graco, Graco will, for a period of twelve months from the date of sale, repair or replace any part of the equipment determined by Graco to be defective. This warranty applies only when the equipment is installed, operated and maintained in accordance with Graco's written recommendations.

This warranty does not cover, and Graco shall not be liable for general wear and tear, or any malfunction, damage or wear caused by faulty installation, misapplication, abrasion, corrosion, inadequate or improper maintenance, negligence, accident, tampering, or substitution of non-Graco component parts. Nor shall Graco be liable for malfunction, damage or wear caused by the incompatibility of Graco equipment with structures, accessories, equipment or materials not supplied by Graco, or the improper design, manufacture, installation, operation or maintenance of structures, accessories, equipment or materials not supplied by Graco.

This warranty is conditioned upon the prepaid return of the equipment claimed to be defective to an authorized Graco distributor for verification of the claimed defect. If the claimed defect is verified, Graco will repair or replace free of charge any defective parts. The equipment will be returned to the original purchaser transportation prepaid. If inspection of the equipment does not disclose any defect in material or workmanship, repairs will be made at a reasonable charge, which charges may include the costs of parts, labor, and transportation.

THIS WARRANTY IS EXCLUSIVE, AND IS IN LIEU OF ANY OTHER WARRANTIES, EXPRESS OR IMPLIED, INCLUDING BUT NOT LIMITED TO WARRANTY OF MERCHANTABILITY OR WARRANTY OF FITNESS FOR A PARTICULAR PURPOSE.

Graco's sole obligation and buyer's sole remedy for any breach of warranty shall be as set forth above. The buyer agrees that no other remedy (including, but not limited to, incidental or consequential damages for lost profits, lost sales, injury to person or property, or any other incidental or consequential loss) shall be available. Any action for breach of warranty must be brought within two (2) years of the date of sale.

Graco makes no warranty, and disclaims all implied warranties of merchantability and fitness for a particular purpose in connection with accessories, equipment, materials or components sold but not manufactured by Graco. These items sold, but not manufactured by Graco (such as electric motors, switches, hose, etc.), are subject to the warranty, if any, of their manufacturer. Graco will provide purchaser with reasonable assistance in making any claim for breach of these warranties.

In no event will Graco be liable for indirect, incidental, special or consequential damages resulting from Graco supplying equipment hereunder, or the furnishing, performance, or use of any products or other goods sold hereto, whether due to a breach of contract, breach of warranty, the negligence of Graco, or otherwise.

FOR GRACO CANADA CUSTOMERS

The parties acknowledge that they have required that the present document, as well as all documents, notices and legal proceedings entered into, given or instituted pursuant hereto or relating directly or indirectly hereto, be drawn up in English. Les parties reconnaissent avoir convenu que la rédaction du présente document sera en Anglais, ainsi que tous documents, avis et procédures judiciaires exécutés, donnés ou intentés à la suite de ou en rapport, directement ou indirectement, avec les procédures concernées.

Graco Information

For the latest information about Graco products, visit www.graco.com.

TO PLACE AN ORDER, contact your Graco distributor or call to identify the nearest distributor.

Phone: 612-623-6921 **or Toll Free:** 1-800-328-0211 **Fax:** 612-378-3505

All written and visual data contained in this document reflect the latest product information available at the time of publication. Graco reserves the right to make changes at any time without notice.

For patent information, see www.graco.com/patents.

Original instructions. This manual contains English. MM 308027

Graco Headquarters: Minneapolis
International Offices: Belgium, China, Japan, Korea

GRACO INC. AND SUBSIDIARIES • P.O. BOX 1441 • MINNEAPOLIS MN 55440-1441 • USA

Copyright 2002, Graco Inc. All Graco manufacturing locations are registered to ISO 9001.

www.graco.com

Revised June 2021