

Air Filters, Lubricators, and Kits

308169W

EN

Maximum Temperature Range 40 - 150° F (4 - 65° C)



Important Safety Instructions

Read all warnings and instructions in this manual before using the equipment. Save these instructions.

Air Filters



217074

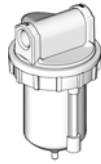

106148

106149

106150 (shown)

112859



110146

Air Lubricators

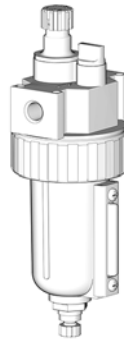

214848



214849
237212



110148

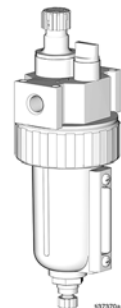

214847

Air Filter-Regulators-Lubricators

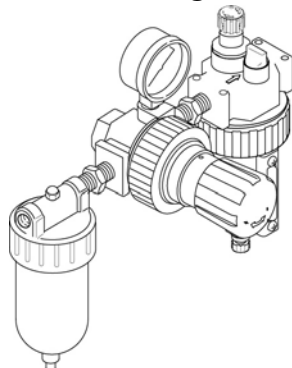

110150 (shown)

217072

217073

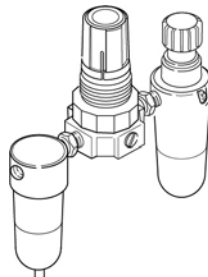

110149

Integral Filters-Regulators

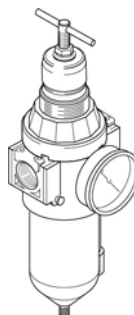

15C955

246947

246948

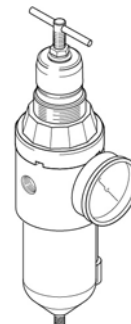

246946

Models

Air Filters

Model	Maximum SCFM	Pump/System Application	Inlet/Outlet	Maximum Working Pressure psi (bar)	Bowl Capacity oz (ml)	Drain Style	Filter Micron
110146	22 (0.62)	Husky 715, Prince, Fast-Flo, Fast-Ball	1/4 npt	300 (21)	1 (30)	Manual	20
106148	80 (2.3)	President, Fire-Ball, Monark	3/8 npt	250 (17.5)	4.4 (132)	Automatic	40
106149	130 (3.7)	Bulldog, Senator, Glutton	1/2 npt	250 (17.5)	7.2 (216)	Manual	40
217074	106 (3.0)	Bulldog, Senator, Glutton	1/2 npt	250 (17.5)	8 (240)	Manual	40
106150	250 (7.0)	King	3/4 npt	250 (17.5)	16 (480)	Manual	40
112859	350 (10.0)	Premier	1 npt	250 (17.5)	16 (480)	Manual	40

Air Lubricators

Model	Maximum SCFM	Pump/System Application	Inlet/Outlet	Maximum Working Pressure psi (bar)	Bowl Capacity oz (ml)	Series
110148	12 (0.34)	Husky, Prince, Fast-Flo, Fast-Ball	1/4 npt	300 (21)	1 (30)	A
214847	60 (1.7)	President, Fire-Ball, Monark	3/8 npt	250 (17.5)	4.9 (147)	B
214848	184 (5.2)	Bulldog, Senator, Glutton	1/2 npt	250 (17.5)	6.1 (183)	B
214849	290 (8.1)	King	3/4 npt	250 (17.5)	16 (480)	A
237212	320 (9.2)	Premier	1 npt	250 (17.5)	16 (480)	A

Air Filter-Regulator-Lubricator Kit (F-R-L)

Model	Includes			GAUGE	Pump/System Application	Inlet/Outlet	Maximum WPR* psi (bar)	Series
	FILTER	REGULATOR	LUBRICATOR					
110149	110146	110318	110148	110319	Husky 715, Prince, Fast-Flo, Fast-Ball	1/4 npt	300 (21)	A
110150	106148	110234	214847	101689	President, Fire-Ball, Monark, Standard	3/8 npt	250 (17.2)	B
217072	106149	104266	214848	101689	Bulldog, Senator, Glutton, Husky 1030	1/2 npt	250 (17.2)	A
217073	106150	207755	214849	101689	King	3/4 npt	250 (17.2)	A

Integral Filter-Lubricators

Model	FILTER	GAUGE	Pump/System Application	Inlet/Outlet	Maximum WPR* psi (bar)
246946	15C956	C36260	Husky 205, 307, 515/716	1/4 npt	250 (17.2)
246947	15C955	C36260	Husky 1040, 1590, and 2150	1/2 npt	250 (17.2)
246948	15C955	C36260	Husky 3275	3/4 npt	250 (17.2)
15C955	n/a	n/a	n/a	1/2 npt	250 (17.2)

Installation

Model 110149

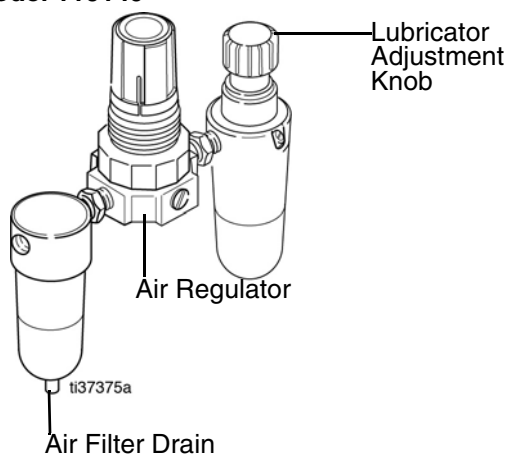

Model 110150
217072
217073 (shown)

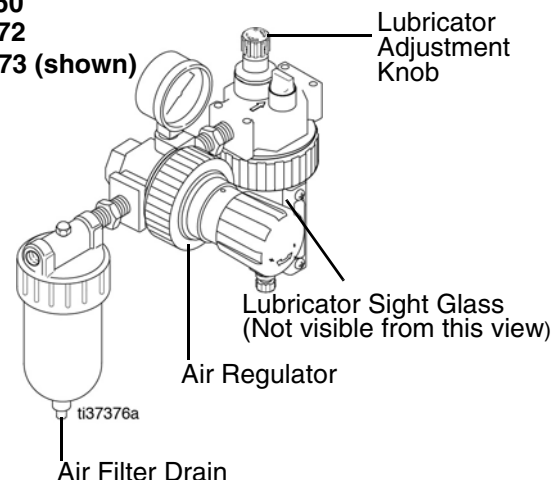

Before installing any air line components, blow out the pipe line to remove scale and other debris. Use pipe compound or tape sparingly and only on male threads.

Install the components in the pipe line so that the flow is in the direction of the arrow stamped on the body.

Locate the air line component(s) as close as possible to the equipment it serves

Install the air filter upstream from the regulator and/or lubricator.

To provide the user with a variety of assembly options, a bleed-type master air valve is not included with FRL's. See **Accessories** on page 13, to order this valve. Another bleed-type master air valve can be installed upstream from the FRL to isolate it for servicing.

Mounting Air Accessories

Use a bracket to mount the air accessories to a wall or cart. Do not hang the accessories directly off the air motor inlet, which could be damaged from the weight and operating stress.

Air Filter

Clean the air filter regularly to maximize filtering efficiency and to avoid excessive pressure drop. Drain contaminants from the bowl before reaching the baffle level. Open the drain to drain the bowl or fully relieve pressure and remove the bowl. Use household soap and water or denatured alcohol for cleaning. Use compressed air to blow out the filter body. Wash the filter element and blow it out from the inside. Clean the sight glass, which may attack or weaken it. If the sight glass appears damaged by the solvent, replace it immediately.

An automatic drain accessory, Part No. 106151, is available for most filters, except for Model 110146, 106148, and 106149. Part No. 127711 is available for Models 106148 and 106049. To install the drain, fully relieve system pressure, then remove the o-ring and bowl. Remove the drain from the bowl and replace it with the automatic drain. Reassemble.

<p>To reduce the risk of serious bodily injury, including skin injection, splashing fluid in the eyes or on the skin, or injury from the pump starting unexpectedly, be sure your system includes a bleed-type master air valve. Install the air valve between the FRL outlet and the device the FRL is serving. When relieving system air pressure, close the bleed-type master air valve to fully relieve air pressure.</p>				



Regulator

The regulator reduces the air supply pressure to a specified, constant downstream pressure to maximize equipment performance. Preset pressures can be locked in. See manual 308167 or 308168 (supplied with the FRL's) for complete air regulator information.

Lubricator

The lubricator meters oil into the moving air stream to lubricate air operated motors. A manual adjustment in the housing sets the oil drip rate into the air stream, which can be monitored through a sight glass on most lubricators. One or two drops of oil a minute is a common adjustment. Use Graco motor oil, Part No. 202659. All lubricators, except Model 110148, can be refilled with the system pressurized. However, always relieve the system pressure before removing the bowl for any reason.

Service

				
<p>Relieve air and fluid pressure before servicing the regulator, filter, or lubricator.</p> <p>To reduce the risk of serious bodily injury, fluid injection, splashing in the eyes or skin, injury from moving parts, always open the bleed-type master air pressure and trigger the gun or dispense valve and open any fluid drain valves to relieve fluid pressure.</p>				

1. Disassemble the component. Refer to the illustrations on pages 4 and 5.
2. Use household soap and water or denatured alcohol for cleaning. Wipe the parts clean with a clean, soft, dry rag. Use compressed air to blow dirt and contaminants out of the lubricator or filter body.
3. Inspect all parts for wear or damage. Replace damaged parts. Use all parts supplied with the kit.

NOTE: The chart identifies the available repair kits for the air filters and lubricators covered in this manual. The cutaway drawings shown on pages 6 and 7 show the contents of the kits.

Repair Kits

Lubricator Repair Kits

Lubricator 214849, 237212

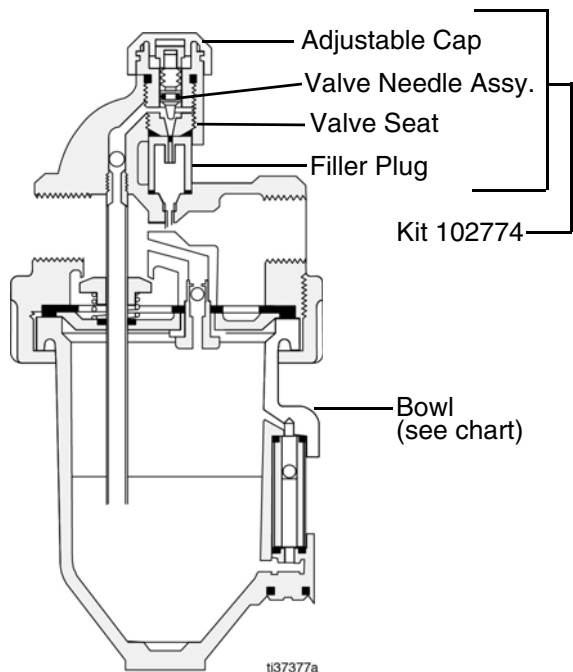

For Lubricator	Kit No.	Description
214848 (Series A)	102774	Repair Kit
214849	102774	Repair Kit

Lubricator 214847, 214848 Series B

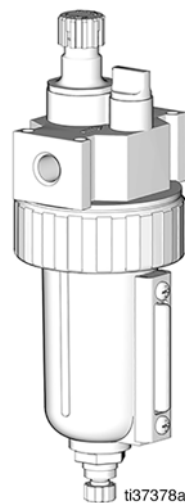

For Lubricator	Kit No.	Description
214847	24U962	Fill Cap Kit
	24U963	Lubricator Service Kit
21848, Series B	17B710	Lubricator Service Kit
	17B709	Lubricator Knob Kit

Filter Elements & Bowl Seals

For Filter	Kit No.	Description	Bowl Seal Part No.
106148	24X967	3/8 in., 40 micron filter element	-----
106149, Series B	17B708	1/2 in., 5 micron filter element	107306
106150	106204	3/4 in., 40 micron filter element	104023
112859	-----	1 in., 40 micron filter element	-----
110146	111690	1/4 in., 20 micron filter element	N/A

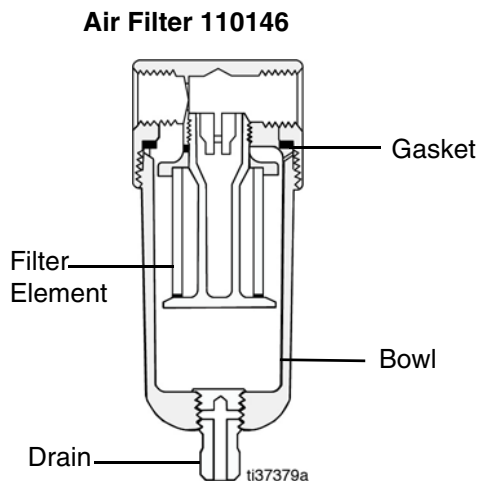

Sight Glass Kits

For Filter	Kit No.	Description
106148	104991	3/8 in. sight glass
106149, Series A	104992	1/2 in. sight glass
106149, Series B	17B706	1/2 in. sight glass
106150	104993	3/4 in. sight glass
112859	104993	1/2 in. sight glass
217074	106197	1/2 in. sight glass

Air Filter 106148, 106149, 106150, 112859, 217074

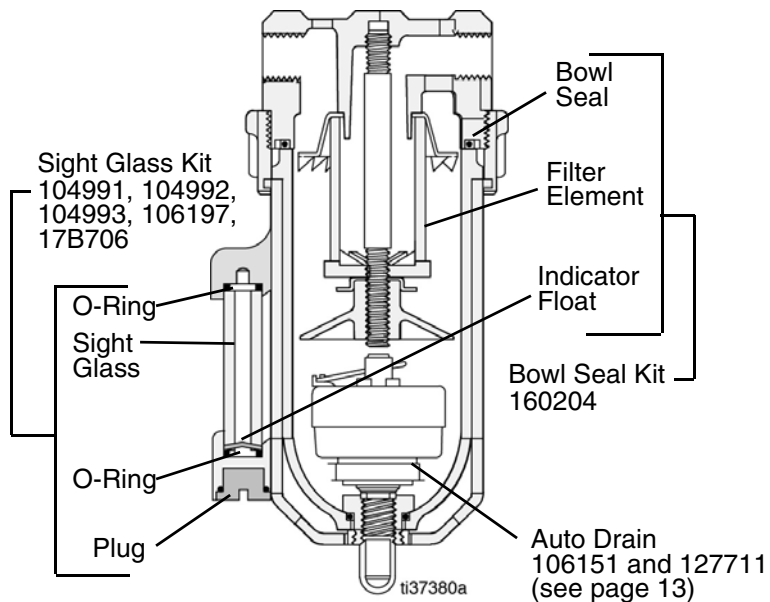

Filter Bowl Replacement Kits with Seal

For Filter	Kit No.	Description
116521	116672	3/4 in. port, bowl w/sight glass
15C955	116672	1/2 in. port, bowl w/sight glass
15C956	248085	1/4 in. port, bowl w/sight glass

Filter Element Kit with Gasket

For Filter	Kit No.	Description
116521	116635	3/4 in. 40 micron filter element
15C955	116635	1/2 in. 40 micron filter element
15C956	248087	1/4 in. 40 micron filter element

Regulator Repair Kit

For Filter	Kit No.	Description
116521	116634	3/4 in. valve and diaphragm
15C955	116634	1/2 in. valve and diaphragm
15C956	248086	1/4 in. valve and diaphragm

Recycling and Disposal

End of Product Life

At the end of a product's useful life, recycle it in a responsible manner.

Parts

Model 110149, Series A
Includes items 1-5

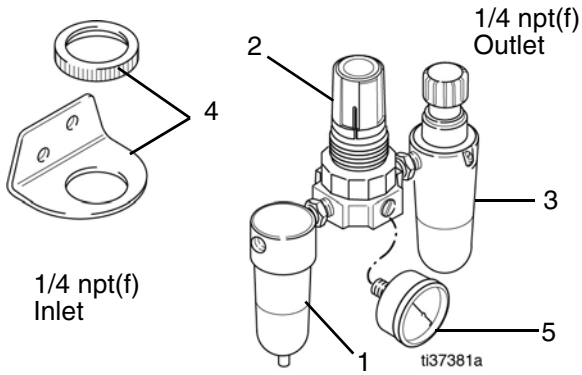

Ref	Part No.	Description	Qty
1	110146	FILTER	1
2	110318	REGULATOR (see 308167)	1
3	110148	LUBRICATOR	1
4	110321	MOUNTING BRACKET	1
5	126032	GAUGE, pressure, 1/8 NPT	1

Model 110150, Series B
Includes items 1-5

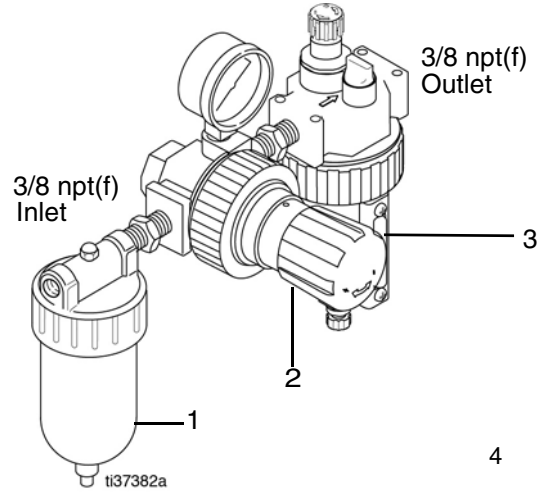

Ref	Part No.	Description	Qty
1	106148	FILTER	1
2	110234	REGULATOR (see 308167)	1
3	214847	LUBRICATOR	1
4	101689	1/4 IN. GAUGE	1

Model 217072, Series A; Includes items 1-5

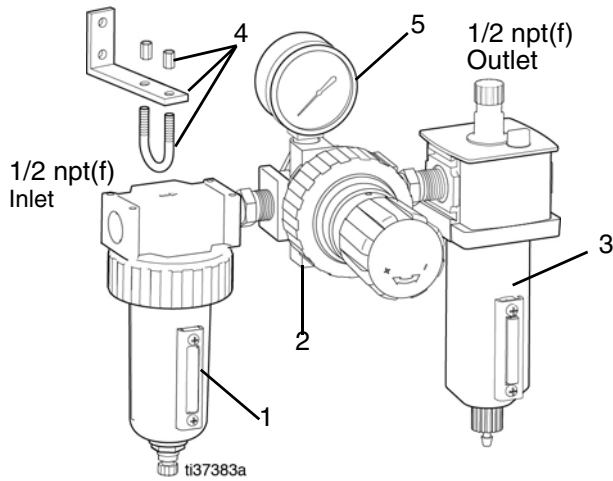

Ref	Part No.	Description	Qty
1	106149	FILTER	1
2	104266	REGULATOR (see 308167)	1
3	214848	LUBRICATOR	1
4	106145	MOUNTING BRACKET	2
5	101689	GAUGE	1

Model 246946

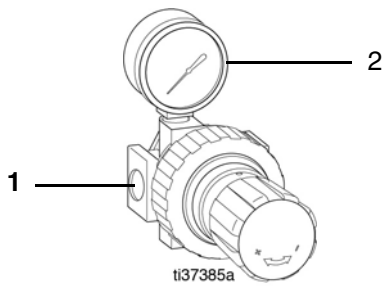

Ref	Part No.	Description	Qty
1	15C956	REGULATOR, filter, air 1/4 npt	1
2	C36260	GAUGE, pressure, air	1

Model 217073, Series A; Includes items 1-5

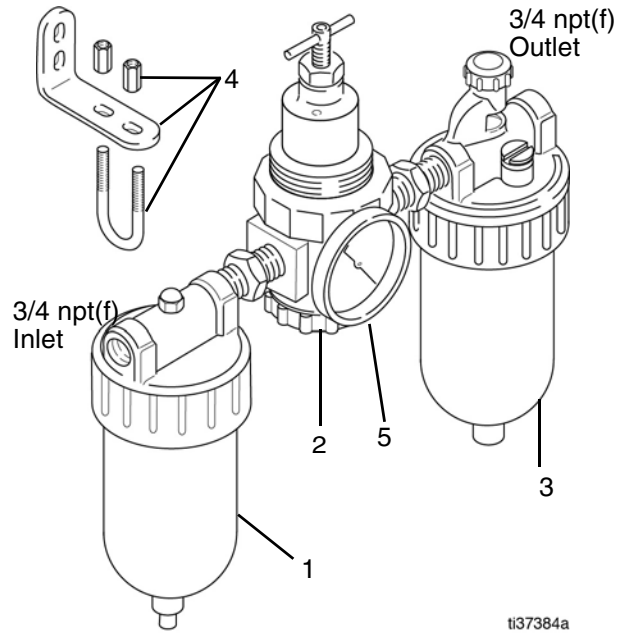

Ref	Part No.	Description	Qty
1	106150	FILTER	1
2	207755	REGULATOR (see 308167)	1
3	214849	LUBRICATOR	1
4	106145	MOUNTING BRACKET	2
5	101689	GAUGE	1

Model 15C955, 246947, and 246948

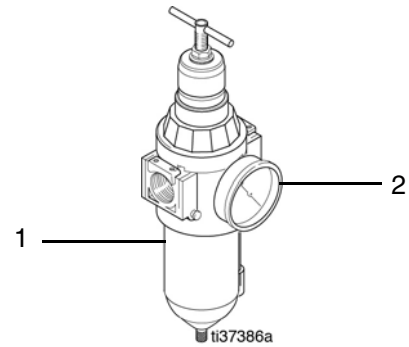

Ref	Part No.	Description	Qty
1	15C955	REGULATOR, filter, air 1/2 npt Model 246947	1
	116521	REGULATOR, filter, air 3/4 npt Model 246948	1
2	C36260	GAUGE, pressure, air Models 246947 and 246948 only	1

Integral Filter-Regulators

Models 15C955,
246947, 246948

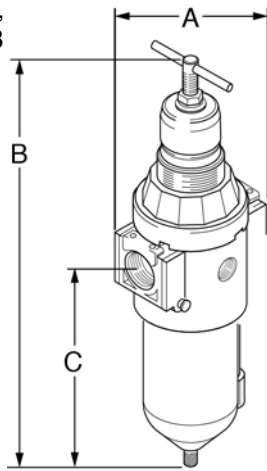

Model 246946

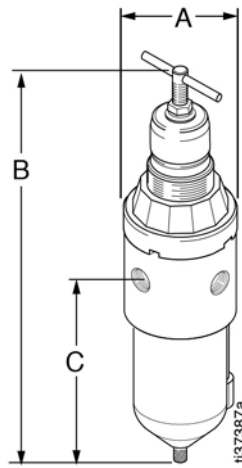

Model	Inlet/Outlet	Width (A) in. (mm)	Height (B) in. (mm)	Height (C) in. (mm)
246946	1/4 npt	2-3/8 (60.32)	9.563 (242.87)	4.938 (125.41)
246947	1/2 npt	3.375 (85.73)	11.375 (288.93)	6.5 (165)
246948	3/4 npt	3.375 (85.73)	11.375 (288.93)	6.5 (165)

Filter-Regulator- Lubricators

Model	Inlet/Outlet	Width (A) in. (mm)	Height (B) in. (mm)	Height (C) in. (mm)	Depth (D) in. (mm)	Height (E) in. (mm)
110149	1/4 npt	5.1 (130)	5.1 (130)	3.5 (89)	1.6 (40)	3.5 (89)
110150	3/8 npt	8.8 (222)	9.6 (244)	5.4 (137)	4.1 (105)	6.9 (177)
217072	1/2 npt	8.1 (206)	11.9 (302)	7.7 (196)	3.3 (83)	7.3 (185)
217073	3/4 npt	15.8 (400)	13 (330)	7.8 (197)	5.0 (127)	7.8 (197)

Model 110149

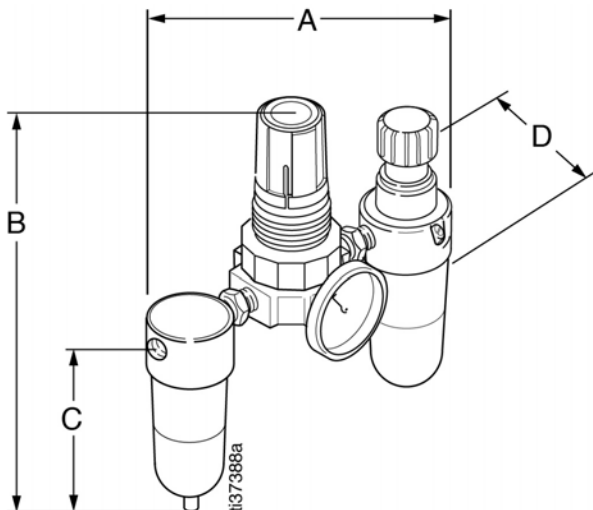

Model 110150, 217072, 217073 (shown)

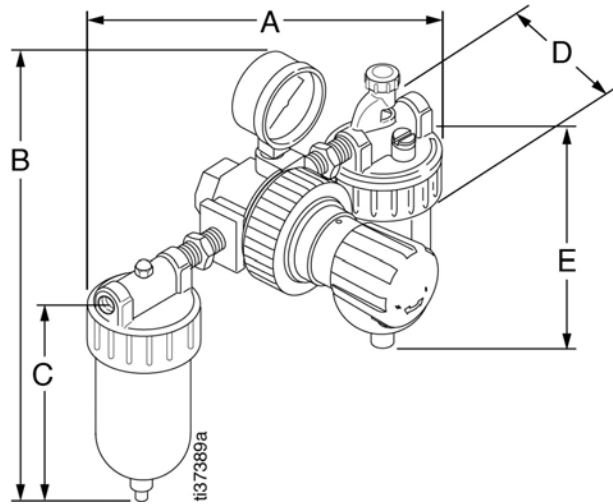

Accessories

Gauges

Model	Air Pressure Range	Inlet	Type of Case	Dial Diameter	Style	Glass P/N
160430	0-100 psi (7 bar)	1/4 npt	Black	2 in. (51 mm)	1	102019
101689	0-200 psi (14 bar)	1/4 npt	Black	2 in. (51 mm)	1	102019
101180	0-200 psi (14 bar)	1/4 npt	Chrome	2 in. (51 mm)	1	102019
101689	0-200 psi (14 bar)	1/4 npt	Chrome	2 in. (51 mm)	2	102019

Style 1 (Bottom Inlet)

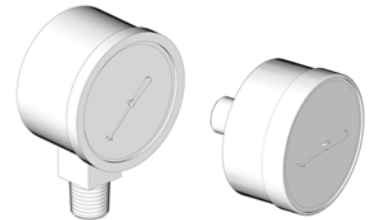

Style 2 (Back Inlet)

Bleed Type Master Air Valve

Part No.	Description
107141	3/4 npt (m x f)
107142	1/2 in. npt (m x f)
110223	1/4-18 npt (fbe)
110224	3/8-18 npt (fbe)
110225	1/2-14 npt (fbe)
110226	3/4-14 npt (fbe)

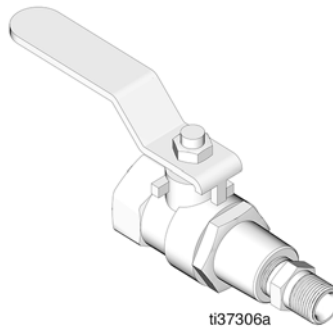

106151 and 127711 AUTOMATIC DRAINS

Installs in place of standard drain for automatic drain. 106151 is used with 106150, 112859 and 217074. 127711 is used with 106148 or 106149, Series B.

NOTE: There is not an auto drain for Model 110146 or 106149, Series A.

202659 AIR MOTOR OIL

For use in lubricators.



114598 MOUNTING BRACKET

Includes two brackets and is used for 1 in. pipe.

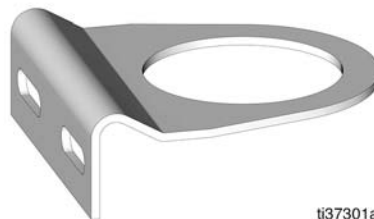

Dimensions

Air Filter

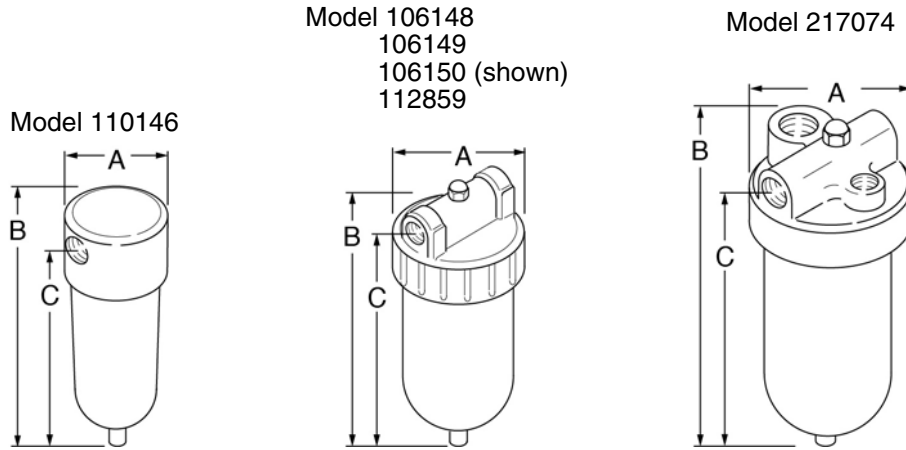

Model	Inlet/Outlet	Width (A) in. (mm)	Height (B) in. (mm)	Height (C) in. (mm)
110146	1/4 npt	1.6 (40)	4.0 (102)	3.6 (91)
106148	3/8 npt	2.5 (64)	6.0 (143)	3.1 (79)
106149	1/2 npt	3.3 (83)	7.7 (196)	7.0 (178)
217074	1/2 npt	3.0 (76)	7.5 (191)	6.6 (168)
106150	3/4 npt	4.0 (102)	8.8 (222)	7.8 (198)
112859	1 npt	4.5 (114)	8.8 (222)	7.9 (201)

Lubricators

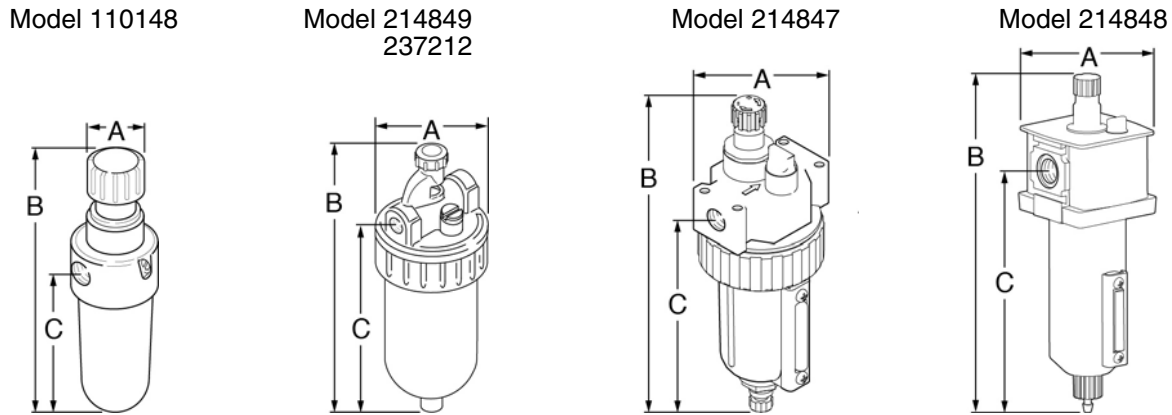

Model	Inlet/Outlet	Width (A) in. (mm)	Height (B) in. (mm)	Height (C) in. (mm)
110148	1/4 npt	1.5 (39)	5.0 (126)	3.0 (76)
214847	3/8 npt	3.24 (82)	7.93 (201)	6.95 (177)
214848, Series B	1/2 npt	2.9 (74)	9.9 (251)	7.3 (184)
214849	3/4 npt	4.0 (103)	9.9 (251)	7.3 (184)
237212	1 npt	4.0 (103)	9.9 (251)	7.3 (184)

Air Filter Flow Curves

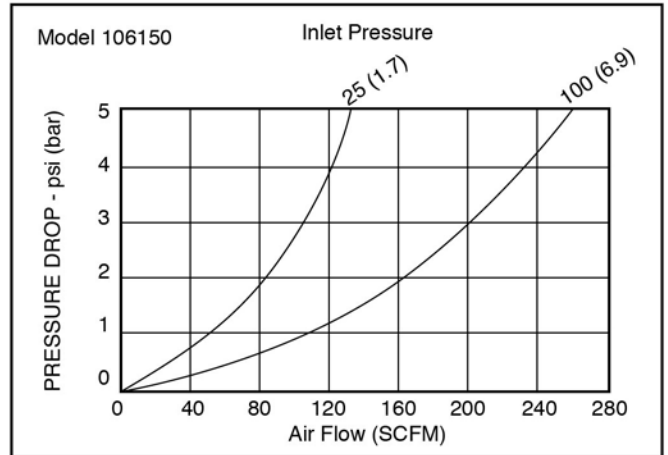
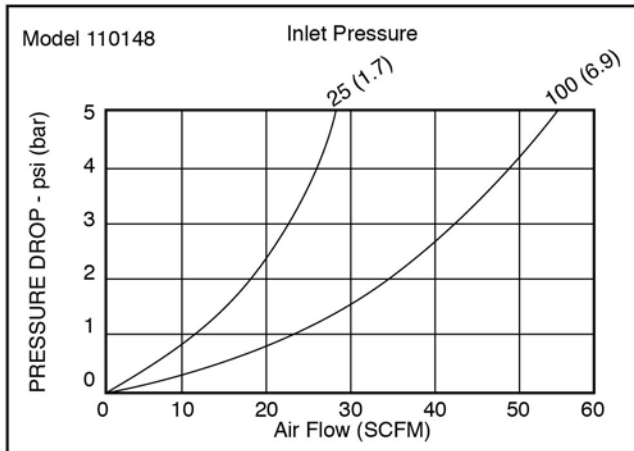
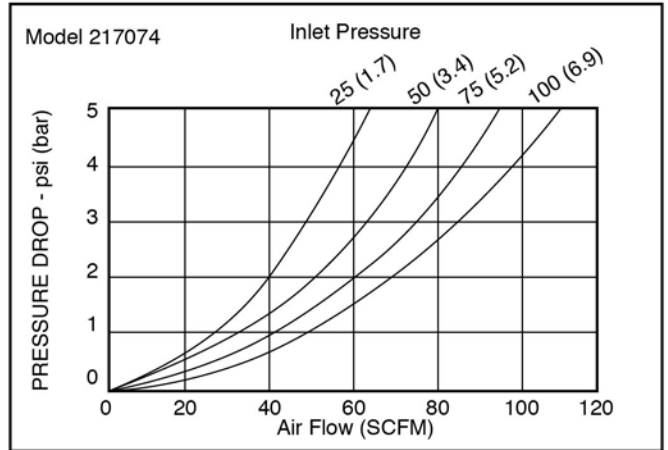
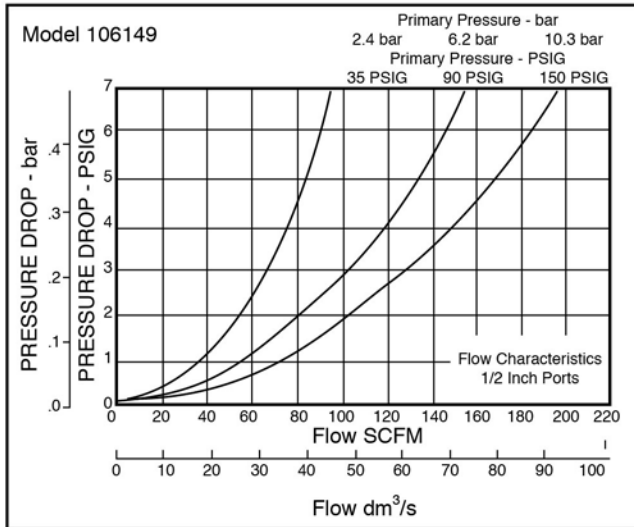
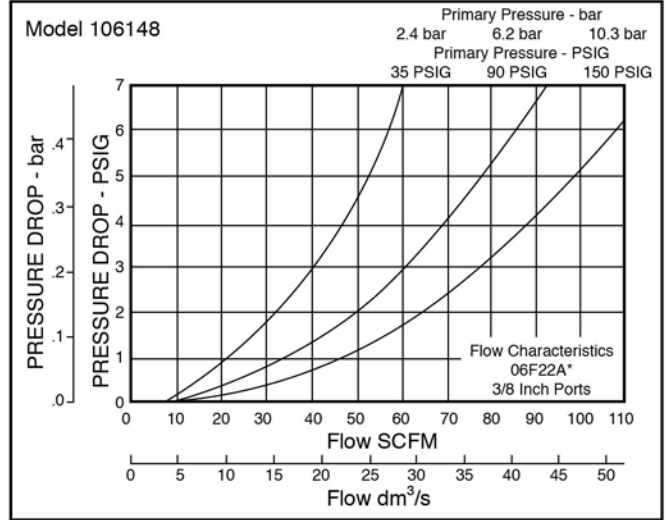
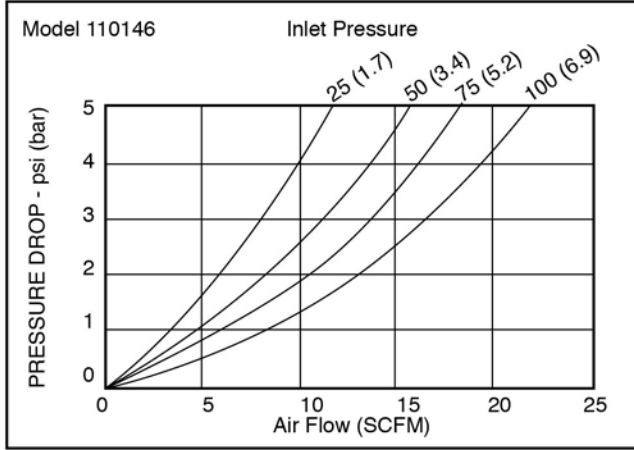

ti24362a

California Proposition 65

CALIFORNIA RESIDENTS

 **WARNING:** Cancer and reproductive harm – www.P65warnings.ca.gov.

Graco Standard Warranty

Graco warrants all equipment referenced in this document which is manufactured by Graco and bearing its name to be free from defects in material and workmanship on the date of sale to the original purchaser for use. With the exception of any special, extended, or limited warranty published by Graco, Graco will, for a period of twelve months from the date of sale, repair or replace any part of the equipment determined by Graco to be defective. This warranty applies only when the equipment is installed, operated and maintained in accordance with Graco's written recommendations.

This warranty does not cover, and Graco shall not be liable for general wear and tear, or any malfunction, damage or wear caused by faulty installation, misapplication, abrasion, corrosion, inadequate or improper maintenance, negligence, accident, tampering, or substitution of non-Graco component parts. Nor shall Graco be liable for malfunction, damage or wear caused by the incompatibility of Graco equipment with structures, accessories, equipment or materials not supplied by Graco, or the improper design, manufacture, installation, operation or maintenance of structures, accessories, equipment or materials not supplied by Graco.

This warranty is conditioned upon the prepaid return of the equipment claimed to be defective to an authorized Graco distributor for verification of the claimed defect. If the claimed defect is verified, Graco will repair or replace free of charge any defective parts. The equipment will be returned to the original purchaser transportation prepaid. If inspection of the equipment does not disclose any defect in material or workmanship, repairs will be made at a reasonable charge, which charges may include the costs of parts, labor, and transportation.

THIS WARRANTY IS EXCLUSIVE, AND IS IN LIEU OF ANY OTHER WARRANTIES, EXPRESS OR IMPLIED, INCLUDING BUT NOT LIMITED TO WARRANTY OF MERCHANTABILITY OR WARRANTY OF FITNESS FOR A PARTICULAR PURPOSE.

Graco's sole obligation and buyer's sole remedy for any breach of warranty shall be as set forth above. The buyer agrees that no other remedy (including, but not limited to, incidental or consequential damages for lost profits, lost sales, injury to person or property, or any other incidental or consequential loss) shall be available. Any action for breach of warranty must be brought within two (2) years of the date of sale.

GRACO MAKES NO WARRANTY, AND DISCLAIMS ALL IMPLIED WARRANTIES OF MERCHANTABILITY AND FITNESS FOR A PARTICULAR PURPOSE, IN CONNECTION WITH ACCESSORIES, EQUIPMENT, MATERIALS OR COMPONENTS SOLD BUT NOT MANUFACTURED BY GRACO. These items sold, but not manufactured by Graco (such as electric motors, switches, hose, etc.), are subject to the warranty, if any, of their manufacturer. Graco will provide purchaser with reasonable assistance in making any claim for breach of these warranties.

In no event will Graco be liable for indirect, incidental, special or consequential damages resulting from Graco supplying equipment hereunder, or the furnishing, performance, or use of any products or other goods sold hereto, whether due to a breach of contract, breach of warranty, the negligence of Graco, or otherwise.

FOR GRACO CANADA CUSTOMERS

The Parties acknowledge that they have required that the present document, as well as all documents, notices and legal proceedings entered into, given or instituted pursuant hereto or relating directly or indirectly hereto, be drawn up in English. Les parties reconnaissent avoir convenu que la rédaction du présente document sera en Anglais, ainsi que tous documents, avis et procédures judiciaires exécutés, donnés ou intentés, à la suite de ou en rapport, directement ou indirectement, avec les procédures concernées.

Graco Information

For the latest information about Graco products, visit www.graco.com.

For patent information, see www.graco.com/patents.

TO PLACE AN ORDER, contact your Graco distributor or call to identify the nearest distributor.

Phone: 612-623-6928 **or Toll Free:** 1-800-533-9655, **Fax:** 612-378-3590

*All written and visual data contained in this document reflects the latest product information available at the time of publication.
Graco reserves the right to make changes at any time without notice.*

Original instructions. This manual contains English. MM 308169

Graco Headquarters: Minneapolis

International Offices: Belgium, China, Japan, Korea

GRACO INC. AND SUBSIDIARIES • P.O. BOX 1441 • MINNEAPOLIS MN 55440-1441 • USA
Copyright 1991, Graco Inc. All Graco manufacturing locations are registered to ISO 9001.

www.graco.com
Revision W, November 2020