

6:1 Fire-Ball[®] 425 Pump

308608M

EN

For pumping non-corrosive and non-abrasive oils and lubricants only. For professional use only.

Not approved for use in European explosive atmosphere locations.

Model 238108, Series D

1100 psi (7.6 MPa, 76 bar) Maximum Working Pressure

180 psi (1.2 MPa, 12 bar) Maximum Air Input Pressure



Important Safety Instructions

Read all warnings and instructions in this manual before using the equipment.
Save these instructions.

Related Manuals

Manual in English	Description
308201	Pump Runaway Valve

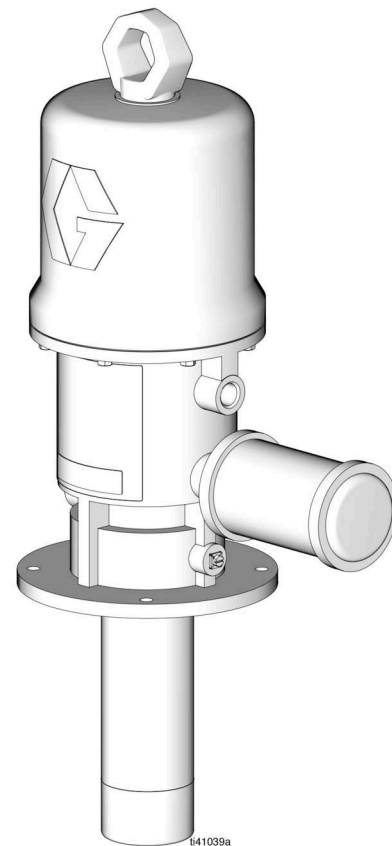









Contents







Related Manuals	1
Warnings	3
Typical Installation	5
Installation	6
System Accessories	6
Grounding	7
Mounting	7
Cover Mount	7
Wall Mount	7
Operation	8
Pressure Relief Procedure	8
Start Up and Adjustment	8
Recycling and Disposal	10
End of Product Life	10
Troubleshooting	11
Repair	12
Air Motor and Throat	12
Disassembly	12
Reassembly	15
Displacement Pump	16
Disassembly	16
Intake Valve	16
Displacement Pump	16
Reassembly	16
Parts	17
Displacement Pump	17
Model 238108, Series D	17
Parts List	17
Air Motor	18
Parts List	19
Performance Charts	20
Dimensions	21
Model 238108 Pump, Series D	21
Mounting Hole Layout	21
Technical Specifications	22
California Proposition 65	23
Graco Standard Warranty	24

Warnings

The following warnings are for the setup, use, grounding, maintenance, and repair of this equipment. The exclamation point symbol alerts you to a general warning and the hazard symbols refer to procedure-specific risks. When these symbols appear in the body of this manual or on warning labels, refer back to these Warnings. Product-specific hazard symbols and warnings not covered in this section may appear throughout the body of this manual where applicable.

 WARNING	
 	<p>EQUIPMENT MISUSE HAZARD Misuse can cause death or serious injury.</p> <ul style="list-style-type: none"> Do not operate the unit when fatigued or under the influence of drugs or alcohol. Do not exceed the maximum working pressure or temperature rating of the lowest rated system component. See Technical Specifications in all equipment manuals. Use fluids and solvents that are compatible with equipment wetted parts. See Technical Specifications in all equipment manuals. Read fluid and solvent manufacturer's warnings. For complete information about your material, request Safety Data Sheets (SDSs) from distributor or retailer. Turn off all equipment and follow the Pressure Relief Procedure when equipment is not in use. Check equipment daily. Repair or replace worn or damaged parts immediately with genuine manufacturer's replacement parts only. Do not alter or modify equipment. Alterations or modifications may void agency approvals and create safety hazards. Make sure all equipment is rated and approved for the environment in which you are using it. Use equipment only for its intended purpose. Call your distributor for information. Route hoses and cables away from traffic areas, sharp edges, moving parts, and hot surfaces. Do not kink or over bend hoses or use hoses to pull equipment. Keep children and animals away from work area. Comply with all applicable safety regulations.
    	<p>SKIN INJECTION HAZARD High-pressure fluid from dispensing device, hose leaks, or ruptured components will pierce skin. This may look like just a cut, but it is a serious injury that can result in amputation. Get immediate surgical treatment.</p> <ul style="list-style-type: none"> Do not point dispensing device at anyone or at any part of the body. Do not put your hand over the fluid outlet. Do not stop or deflect leaks with your hand, body, glove, or rag. Follow the Pressure Relief Procedure when you stop dispensing and before cleaning, checking, or servicing equipment. Tighten all fluid connections before operating the equipment. Check hoses and couplings daily. Replace worn or damaged parts immediately.

WARNING

	<p>TOXIC FLUID OR FUMES HAZARD</p> <p>Toxic fluids or fumes can cause serious injury or death if splashed in the eyes or on skin, inhaled, or swallowed.</p> <ul style="list-style-type: none"> • Read Safety Data Sheets (SDSs) to know the specific hazards of the fluids you are using. • Store hazardous fluid in approved containers, and dispose of it according to applicable guidelines.
	<p>PRESSURIZED ALUMINUM PARTS HAZARD</p> <p>Use of fluids that are incompatible with aluminum in pressurized equipment can cause serious chemical reaction and equipment rupture. Failure to follow this warning can result in death, serious injury, or property damage.</p> <ul style="list-style-type: none"> • Do not use 1,1,1-trichloroethane, methylene chloride, other halogenated hydrocarbon solvents or fluids containing such solvents. • Do not use chlorine bleach. • Many other fluids may contain chemicals that can react with aluminum. Contact your material supplier for compatibility.
 	<p>FIRE AND EXPLOSION HAZARD</p> <p>When flammable fluids are present in the work area, such as gasoline and windshield wiper fluid, be aware that flammable fumes can ignite or explode. To help prevent fire and explosion:</p> <ul style="list-style-type: none"> • Use equipment only in well-ventilated area. • Eliminate all ignition sources, such as cigarettes and portable electric lamps. • Ground all equipment in the work area. • Keep work area free of debris, including rags and spilled or open containers of solvent and gasoline. • Do not plug or unplug power cords or turn lights on or off when flammable fumes are present. • Use only grounded hoses. • Stop operation immediately if static sparking occurs or you feel a shock. Do not use equipment until you identify and correct the problem. • Keep a working fire extinguisher in the work area.
 	<p>MOVING PARTS HAZARD</p> <p>Moving parts can pinch, cut or amputate fingers and other body parts.</p> <ul style="list-style-type: none"> • Keep clear of moving parts. • Do not operate equipment with protective guards or covers removed. • Equipment can start without warning. Before checking, moving, or servicing equipment, follow the Pressure Relief Procedure and disconnect all power sources.
	<p>PERSONAL PROTECTIVE EQUIPMENT</p> <p>Wear appropriate protective equipment when in the work area to help prevent serious injury, including eye injury, hearing loss, inhalation of toxic fumes, and burns. Protective equipment includes but is not limited to:</p> <ul style="list-style-type: none"> • Protective eyewear, and hearing protection. • Respirators, protective clothing, and gloves as recommended by the fluid and solvent manufacturer.

Typical Installation

The typical installation shown in FIG. 1 is only a guide for selection and installation of a pump. It is not an actual system design. Contact your Graco representative or Graco distributor for assistance in the design of a suitable system.

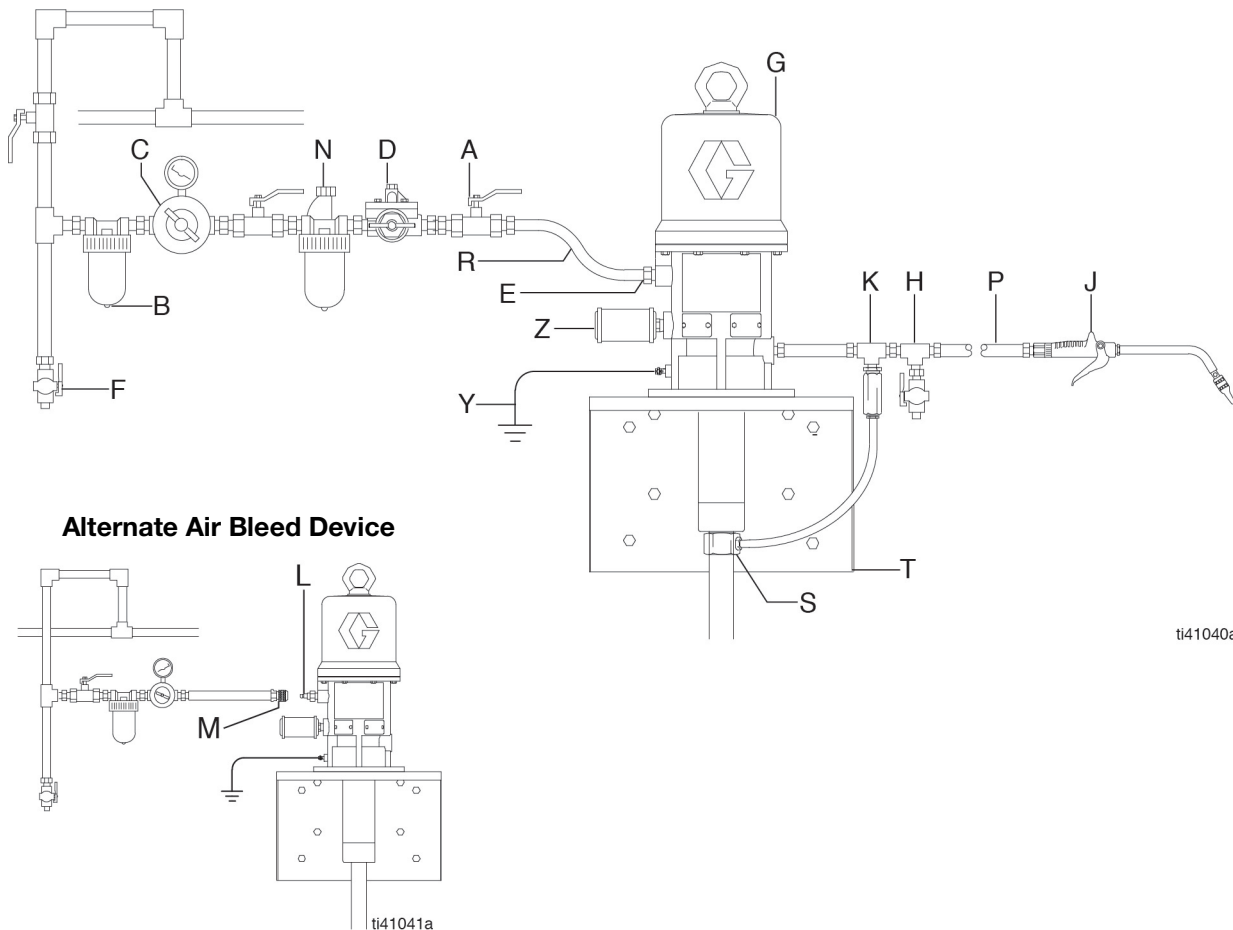

ti41040a

FIG. 1: Typical Installation

Key:

- A Bleed-type master air valve (required)
- B Air line filter
- C Air regulator and gauge
- D Pump runaway valve (shown for position) - not needed if using a low-level cut-off valve
- E Air inlet
- F Ball valve (for releasing collected moisture)
- G Pump
- H Drain valve (required)
- J Dispensing valve (model 222411 shown)
- K Thermal relief kit (required) Part No. 240429
- L Male quick-disconnect pin fitting (alternative to A)
- M Female quick-disconnect coupler (alternative to A)
- N Air line lubricator
- P Fluid hose
- R Electrically conductive air hose (218093 shown)
- S Fluid inlet
- T Wall mounting bracket
- Y Ground wire (required)
- Z Muffer

NOTICE

Always mount the pump firmly to a bracket or a tank cover. Do not operate the pump if it is not mounted, doing so could damage the pump and the fittings.

Installation

System Accessories

Install the accessories shown in FIG. 1.

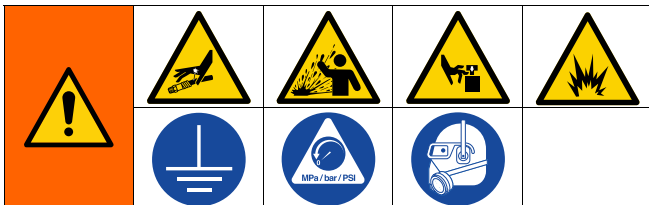

Four accessories are required in the system: an air shut-off valve's bleed device, fluid drain valve, thermal relief kit, and ground wire. These accessories help reduce the risk of serious bodily injury including fluid injection, splashing in the eyes or on the skin, injury from moving parts if adjusting or repairing the pump, and explosion from static sparking.

The air bleed device relieves air trapped between it and the air motor after the air supply is shut off. Trapped air can cause the air motor to cycle unexpectedly, causing serious bodily injury when adjusting or repairing the pump. Use either a bleed-type master air valve (A) or a quick-disconnect coupler with male quick-disconnect pin fitting (L). Install near the pump air inlet, within easy reach of the pump.

The fluid drain valve (H) assists in relieving fluid pressure in the displacement pump, hoses and dispensing valve. Triggering the dispensing valve (J) to relieve pressure may not be sufficient.

The thermal relief kit assists in relieving pressure in the pump, hose, and dispensing valve due to heat expansion.

The ground wire reduces the risk of static sparking.

1. Insert the muffler (5) into the 3/4 in. npt muffler port and tighten using a wrench on the flats of the muffler near the male threads.
2. Install an air line lubricator (N) for automatic air motor lubrication.
3. Install an air regulator (C) to control the pump speed and pressure.
4. Install an air line filter (B) to remove harmful dirt and contaminants from the compressed air supply.
5. Install a bleed-type master air valve (A) to isolate the accessories for servicing. See FIG. 1. To order a bleed-type master air valve, order Part No. 107142.

As an alternative to a bleed-type master air valve, installation of an air line female quick-disconnect coupler (M) and male quick-disconnect pin fitting (L) (see FIG. 1) can serve as an air-bleed device.
6. Install a drain valve (H) near the pump fluid outlet to relieve fluid pressure in the hoses and gun when opened. To order a fluid drain valve, order Part No. 210658.
7. Install a thermal relief kit (K) on the dispensing valve side of the pump. To order a 1600 psi (11 MPa, 110 bar) thermal relief kit, order Part No. 240429.
8. Install a suitable fluid hose (P) and dispensing valve (J).

Grounding



The equipment must be grounded to reduce the risk of static sparking. Static sparking can cause fumes to ignite or explode. Grounding provides an escape wire for the electric current.

1. Remove the ground screw (Z) located on the side of the pump base.
2. Insert the ground screw (Z) through the eye of the ring terminal (W) located at the end of the ground wire (Y).
3. Fasten the ground screw (Z) back onto the back of the pump and tighten the screw securely.
4. Connect the other end of the ground wire (Y) to a true earth ground.

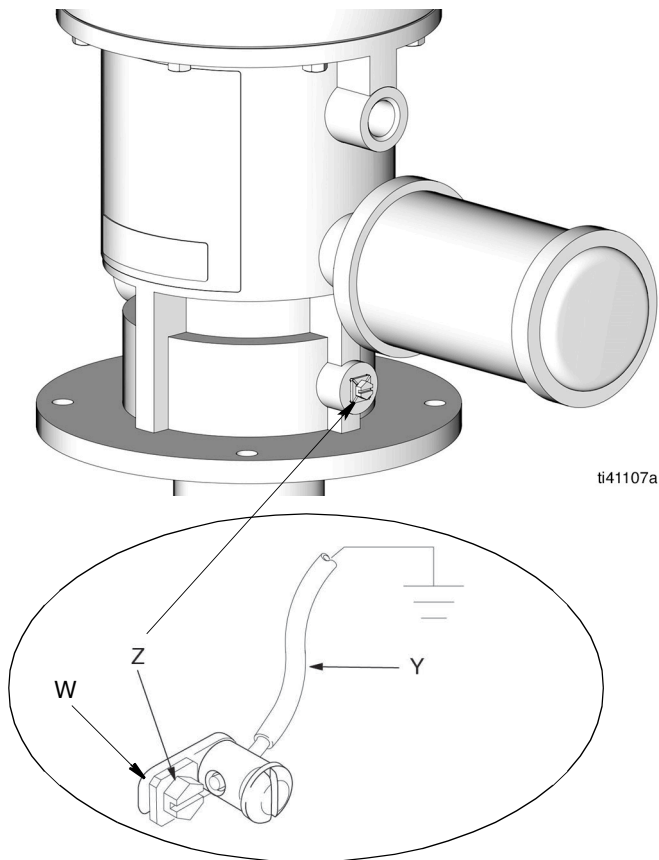

FIG. 2

Mounting



Mount the pump securely so that it cannot move around during operation. Failure to do so could result in injury or equipment damage.

Install the pump in a location that will adequately support the weight of the pump when it is filled with lubricant and also provides easy operator access to the pump air controls. The pump must be mounted in a vertical position. See **Technical Specifications**, page 22 for pump weight information and the **Dimensions** and **Mounting Hole Layout**, page 21.

Cover Mount

For cover mounting, see the **Mounting Hole Layout**, page 21.







Wall Mount

The pump shown in FIG. 1 is wall mounted. To order the wall mounting bracket, order Part No. 238425.

Operation

Pressure Relief Procedure





 Follow the Pressure Relief Procedure whenever you see this symbol.

This equipment stays pressurized until pressure is manually relieved. To help prevent serious injury from pressurized fluid, such as skin injection, splashing fluid and moving parts, follow the Pressure Relief Procedure when you stop dispensing and before cleaning, checking, or servicing the equipment.

1. Close the bleed-type master air valve (A) (required in the system) or female quick-disconnect coupler (M).
2. Hold a metal part of the dispensing valve (J) firmly to a grounded metal waste container and trigger the valve to relieve the fluid pressure.
3. Open the drain valve (H).

Start Up and Adjustment



				
---	--	---	---	--

COMPONENT RUPTURE HAZARD
 The maximum working pressure of each component in the system may not be the same. To reduce the risk of over-pressurizing any component in the system, be sure you know the maximum working pressure of each component. Never exceed the maximum working pressure of the lowest rated component in the system. Over-pressurizing can result in rupture, fire, explosion, property damage, and serious injury.

Limit the air to the pump so that no air line or fluid line component or accessory is over-pressurized.

To determine the fluid output pressure using the air regulator reading, multiply the ratio of the pump by the air pressure shown on the regulator gauge. For example:

- 6 (:1) ratio x 180 psi air = 1080 psi fluid output
- 6 (:1) ratio x 7 bar air = 42 bar fluid output
- 6 (:1) ratio x 0.7 MPa air = 4.2 MPa fluid output

				
---	--	---	--	--

The air motor exhaust coming out of the muffler could contain harmful materials, such as oil, anti-freeze, or some of the material being pumped.

Wear appropriate protective equipment when in the work area to help prevent serious injury, including inhalation of toxic fumes.



1. With the air regulator (C) closed, open the bleed-type master air valves (A), or, if so equipped, join the female quick-disconnect coupler (M) to the male quick-disconnect pin fitting (L).
2. Open the dispensing valve (J) into a grounded metal waste container, making firm metal-to-metal contact between the container and valve,
3. Open the pump air regulator (C) slowly, just until the pump is running. When the pump is primed and all

of the air has been pushed out of the lines, close the dispensing valve.

NOTE: When the pump is primed, and with sufficient air supplied, the pump starts when the dispensing valve is opened and shuts off when it is closed.

4. If the system is equipped with a runaway valve (D), set it for the system configuration. See Pump Runaway Valve manual for setting instructions.
5. Adjust the air regulator until there is sufficient flow from the dispensing valve. Always run the pump at the lowest speed necessary for the desired results, making sure not to exceed the maximum working pressure of any component in the system.

NOTE: Stop the pump if it is accelerating too quickly or is running too fast, and check the fluid supply. If the supply container is empty and air has been pumped into the lines, prime the pump and lines with fluid, or flush it and leave filled with a compatible solvent. Ensure that all air is eliminated from the fluid lines. If the system has a runaway valve, reset it according to the instructions in the Pump Runaway Valve manual.

				
Do not allow the pump to run dry of the fluid being pumped. A dry pump will quickly accelerate to a high speed, possibly damaging itself, and it may become very hot.				

6. Read and follow the instructions supplied with each of your system components.
7. If the pump will be unattended for any period of time, if there is an air supply interruption, or to shut off the system at the end of the work shift, relieve pressure following the **Pressure Relief Procedure**, page 8.
8. Periodically check that the pump's mounting is secure.

Recycling and Disposal

End of Product Life

At the end of the product's useful life, dismantle and recycle it in a responsible manner.

- Perform the Pressure Relief Procedure in your pump manual.
- Drain and dispose of fluids according to applicable regulations. Refer to the material manufacturer's Safety Data Sheet.
- Deliver remaining product to a recycling facility.

Troubleshooting

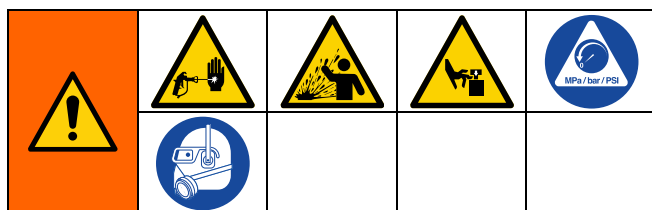

1. Follow **Pressure Relief Procedure**, page 8, before checking or repairing the pump.
2. Check all possible problems and causes before disassembling pump.

Problem	Cause	Solution
Pump fails to operate.	Inadequate air supply pressure or restricted air lines	Increase air supply; clear
	Closed or clogged dispensing valve	Open; clear
	Clogged fluid lines, hoses, valves, etc.	Clear*
	Damaged air motor	Service air motor
	Exhausted fluid supply	Refill and re-prime or flush
Continuous air exhaust	Worn or damaged air motor gasket, packing, seal, etc.	Service air motor
Erratic pump operation	Exhausted fluid supply	Refill and re-prime or flush
	Held open or worn intake valve or piston packings	Clear; service
Pump operates, but output low on up stroke	Held open or worn piston packings	Clear; service
Pump operates, but output low on down stroke	Held open or worn intake valve	Clear; service
Pump operates, but output low on both strokes	Inadequate air supply pressure or restricted air lines	Increase air supply; clear
	Closed or clogged valves	Open; clear
Fluid is coming out of the muffler	Worn or damaged throat seal	Repair

*Follow the **Pressure Relief Procedure**, page 8, then disconnect the fluid line. If the pump starts when the air is turned on again, there is a clog in the line, hose, valve, etc.

Repair

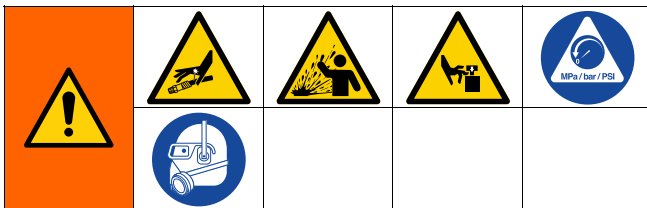

This equipment stays pressurized until pressure is manually relieved. To help prevent serious injury from pressurized fluid, such as skin injection, splashing fluid and moving parts, follow the Pressure Relief Procedure when you stop dispensing and before cleaning, checking, or servicing the equipment.

Air Motor and Throat

Refer to FIG. 3 for the following instructions.

Disassembly

Two accessory tools should be used: Padded Pliers, 270579, are used to grip the trip rod without damaging the surface, and a 0.125 in. (3.18 mm) Gauge, 171818, is used to assure the proper clearance between the poppets and seat of the piston.

1. Flush the pump.
2. Relieve pressure. Follow the **Pressure Relief Procedure**, page 8.
3. Disconnect the hoses, remove the pump from its mounting, and clamp the air motor base (28) in a vise horizontally by closing the vise jaws on the flange.

4. Use a strap wrench on the displacement pump cylinder (110) to unscrew it out of the air motor base (28).
5. Remove the piston/valve seat (109) from the rod (29) with wrenches or with the vise and a wrench.
6. Remove the piston ball (103), u-cup packing (107†), and piston washer (113).
7. Remove the air motor base from the vise, and place the piston rod (29) flats in the vise with the air motor facing up.
8. Loosen the lift ring (24). Pull up the lift ring, grip the trip rod (31) with the padded pliers, and screw the lift ring off of the rod.

NOTICE

Do not damage the plated surface of the trip rod (31). Damaging the surface of the trip rod can result in erratic air motor operation. Use the padded pliers (207579) to grasp the rod.

9. Remove the eight screws (3) holding the cylinder (30) to the base (28). Carefully pull the cylinder straight up off of the piston assembly (27).

NOTICE

Lift the cylinder straight up off of the piston to avoid damaging the cylinder wall. Never tilt the cylinder as it is being removed.

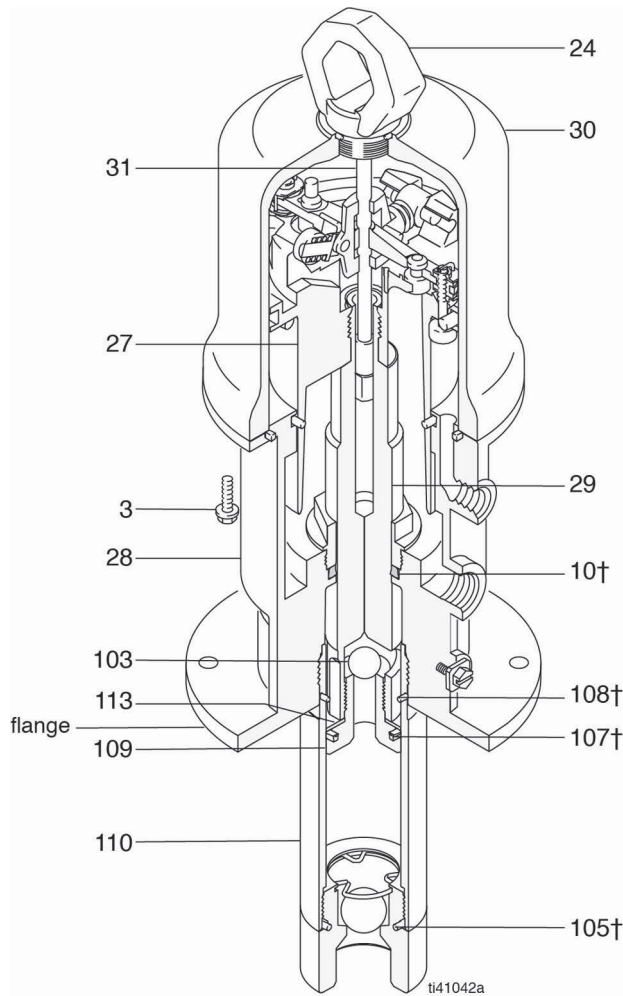

FIG. 3

†Included in Pump Repair Kit 238225, which may be purchased separately.

10. Pull the piston assembly from the air motor base (28) and set it aside.
11. Remove the throat bearing (36) with a 2 in. socket, remove the u-cup seal (10†), and wipe the seat clean with a cloth.
12. Remove the piston/base from the vise and set it upright on the workbench.
13. Inspect the air motor for damaged or worn inlet valve grommets (17*), o-rings (19*, 20*), valve nuts (21*), lock wires (22*), exhaust valve poppets (26*), or inlet valve poppets (32*).

If any of these parts need to be replaced, continue with the remaining Disassembly steps. Otherwise, go to **Reassembly**, page 15.

<p>To reduce the risk of pinching or amputation of fingers, keep fingers clear of the toggle assemblies when snapping the toggles (M in FIG. 4) up or down.</p>				

14. Using a screwdriver, push down on the trip rod yoke (13), and snap the toggles down (FIG. 4).
15. For this step, while prying with the screwdriver with one hand, cover the toggle assemblies with the other hand to catch the spring-loaded toggle assemblies as they snap out of the lugs. Place the tip of the screwdriver into the piston between the piston lugs (L) below the pivot pins (16) on the toggles, pry up using the screwdriver handle to compress the springs on the toggle assembly (M) up and away from the piston lugs, and remove the parts (FIG. 4).
16. Straighten the lock wires (22*) and remove them from the valve nuts (21*). Screw the top nuts off. Remove the trip rod yoke (13), actuator (12), and trip rod (31). Unscrew the bottom nuts (21*) and remove the poppets. Make sure the valve bar spring clips (14) are not worn or damaged, and that they properly guide the actuator (12).
17. Remove the exhaust valve poppets (26) by cutting them with a side cutter, then pull them out of the actuator (12).
18. Clean all of the parts carefully in a compatible solvent and inspect them for wear or damage. Use all of the repair kit parts during reassembly, and replace other parts as necessary.
19. Check the surfaces of the piston, piston rod, and cylinder wall for scratches or wear. A scored rod will cause premature packing wear and leaking.
20. Lubricate all of the parts with a light, waterproof grease.

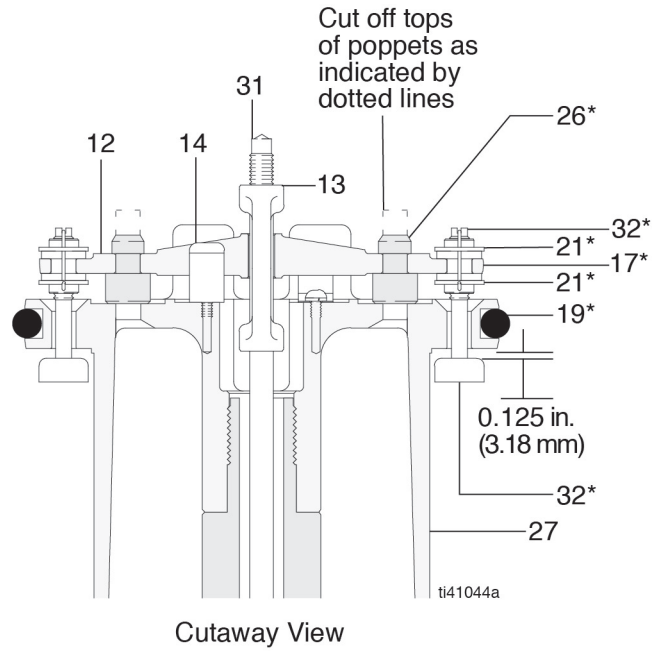
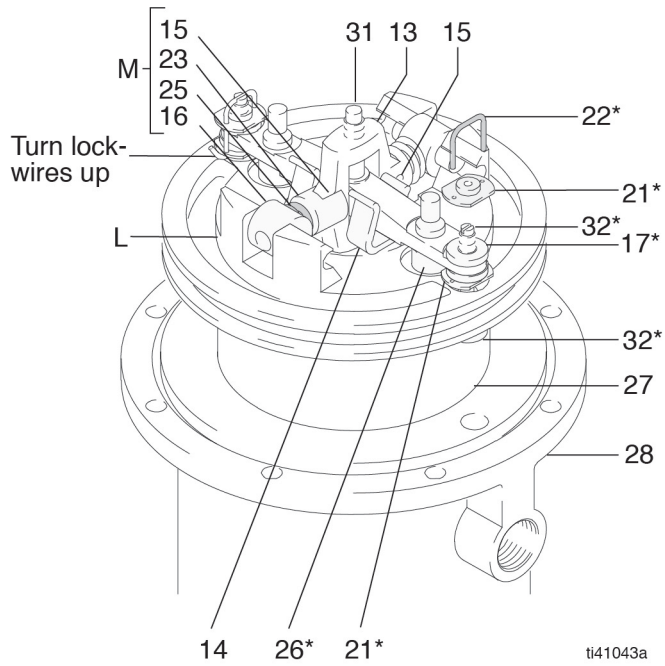

Fig. 4 Air Motor and Throat

Reassembly

Ensure that all necessary parts are on hand. Air Motor Repair Kit 207385 includes repair parts for the motor. For best results, use all of the parts in the kit. Parts included in the kit are marked with an asterisk in the text and drawings, for example (19*). See **Parts List**, page 19.

1. Place the piston rod (29) flats in the vise with the air motor facing up.
2. Pull the exhaust valve poppets (26*) into the valve actuator (12), and clip off the top parts of the poppets (shown with dotted lines in the Cutaway View in FIG. 4).
3. Install the grommets (17*) in the actuator (12), place the inlet valve poppets (32*) in the piston, and thread the bottom valve nuts (21*) onto the inlet valve poppets until there are a few threads left before the threads run out.

NOTE: If the valve nuts are threaded too far down onto the poppets, they will run off of the threaded part of the poppets.

4. Grease heavily and place the trip rod (31) in the piston, place the actuator (12) in the yoke (13), and place the well-greased actuator/yoke assembly in the piston, with the trip rod going through the center holes of the actuator and yoke and the inlet valve poppets (32*) going through the grommets (17*).
5. Thread the top valve nuts (21*) onto the inlet valve poppets (32*) until one thread of the inlet valve poppets is exposed above the valve nuts.
6. Install the toggle pins (15) in the yoke (13), place the toggle arm (23) ends of the toggle assembly (M) onto the toggle pins, and snap the pivot pin (16) ends of the toggle assembly into the lugs (L).
7. Measuring with the gauge (Part No. 171818), create 0.125 in. (3.18 mm) of clearance between the inlet valve poppets (32*) and the piston seat when the inlet valve is open. See the Cutaway View in FIG. 4.

NOTE: Adjust the distance between the inlet valve poppets and the piston seat by turning the top valve nuts (21*).

8. Hand-tighten the bottom valve nuts (21*) securely.

NOTICE

Do not reuse the old lock wires. They become brittle and break from too much bending.

9. Align the holes in the valve nuts (21*) and the slots on the top of the inlet valve poppets (32*), and drop the lock wires (22*) through the holes in the valve nuts and into the slots in the inlet valve poppets. Pull the lock wires down tightly, and bend the ends with pliers so that they cannot be pulled back out of the holes.
10. Grease and install the new o-rings (19*, 20*) on the piston assembly (27) and in the groove in the air motor base (28).
11. Clamp the air motor base (28) in a vise horizontally by closing the vise jaws on the flange.
12. Grease and reinstall the u-cup seal (10†), thread and throat bearing (36) into the air motor base (28), and torque the throat bearing to 30 to 40 ft.-lbs (40.7 to 54.2 N•m) using a 2 in. socket.
13. Slide the piston rod (29) down through the packing, and lower the piston assembly (27) into the air motor base (28).
14. Carefully lower the cylinder (30) straight down onto the piston assembly (27). Tighten the eight screws (3) holding the cylinder to the base (28).

NOTICE

To avoid damaging the cylinder wall, lower the cylinder straight down onto the piston. Never tilt the cylinder as it is being lowered.

15. Grip the trip rod (31) with padded pliers, screw the lift ring (24) onto the trip rod, push the lift ring down, and screw it into the top of the cylinder.
16. Install the u-cup packing (107†) with the lips facing up, and place the piston washer (113) on the piston/valve seat (109). Make sure that the lips of the u-cup packing face up (FIG. 3)
17. Place the piston ball (103) in the piston rod (29).
18. Clean the threads of the piston/valve seat. Apply thread locking compound to the threads (109), and thread the assembly from step 16 onto the piston rod (29).

19. Clamp the flats of the piston/valve seat (109) in a vise, and torque the piston rod (29) to the piston valve seat to 40 to 60 ft.-lbs (54 to 81 N•m).
20. Clamp the air motor base (28) in a vise horizontally by closing the vise jaws on the flange.
21. Use a strap wrench to screw the displacement pump cylinder (110) to the air motor base (28), and torque to 95 to 105 ft.-lbs (129 to 142 N•m).
22. Before remounting the pump, connect an air hose and run the air motor slowly, starting with just enough air pressure to make the air motor run, to make sure that it operates smoothly.
23. Reconnect the ground wire before regular operation of the pump.

Displacement Pump

Disassembly

Displacement Pump Repair Kit 238225 includes repair parts for the pump throat and piston. For best results, use all of the parts in the kit. Parts included in the kit are marked with a dagger, for example (7†), in the text and drawings. See **Parts List**, page 17.

1. Flush the pump.
2. Relieve pressure. Follow the **Pressure Relief Procedure**, page 8.
3. Disconnect the hoses, remove the pump from its mounting, and clamp the air motor base (28) in a vise horizontally by closing the vise jaws on the flange.

Intake Valve

Refer to FIG. 5 for the following instructions.

1. Relieve pressure. Follow the **Pressure Relief Procedure**, page 8.
2. Unscrew the valve housing (111). Remove the o-ring (105†), retainer (112), and ball (104).

3. Inspect the parts for wear or damage. If the ball is nicked, replace it. Reassemble, using grease on the male threads.

Displacement Pump

Refer to FIG. 5 for the following instructions.

Clean and inspect all parts for wear or damage during disassembly. Replace parts as needed. For best results, always replace all of the o-rings and packings during disassembly of the pump.

1. Relieve pressure. Follow the **Pressure Relief Procedure**, page 8.
2. Follow steps 1 to 7 of **Air Motor and Throat Disassembly**, page 12.
3. Carefully inspect the smooth inner surface of the cylinder (110) for scoring or irregular surfaces. Such damage causes premature seal wear and leaking. Replace the cylinder as needed.

Reassembly

Follow steps 16 through 23 of **Air Motor and Throat Reassembly**, page 15.

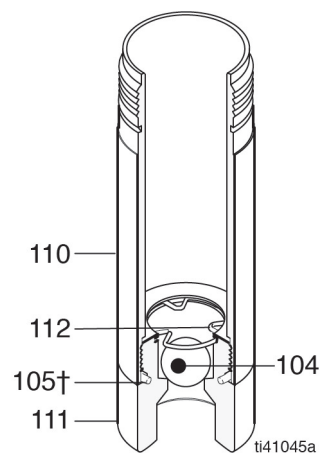

FIG. 5

†Included in Pump Repair Kit 238225, which may be purchased separately.

Parts

Displacement Pump

Model 238108, Series D

Air motor not listed or shown here. See pages 18 and 19.

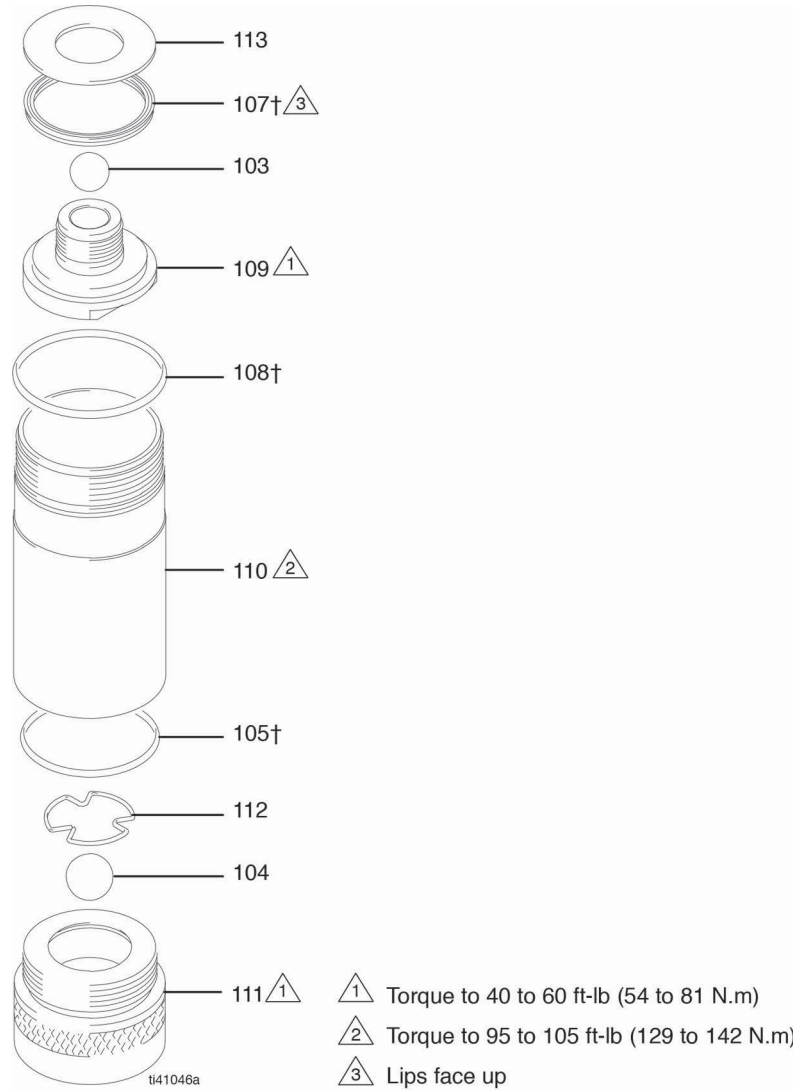

Parts List

Ref.	Part	Description	Qty.	Ref.	Part	Description	Qty.
				109	194016	PISTON	1
107†	113345	SEAL, u-cup (shown on page 18)	1	110	190922	CYLINDER, pump	1
103	101190	BALL, piston; metallic	1	111	190926	VALVE HOUSING	1
104	101178	BALL; sst	1	112	190928	RETAINER, ball	1
105†	113347	PACKING, o-ring	1	113	190924	WASHER, piston	1
107†	113346	PACKING, u-cup	1				
108†	112349	PACKING, o-ring	1				

Air Motor

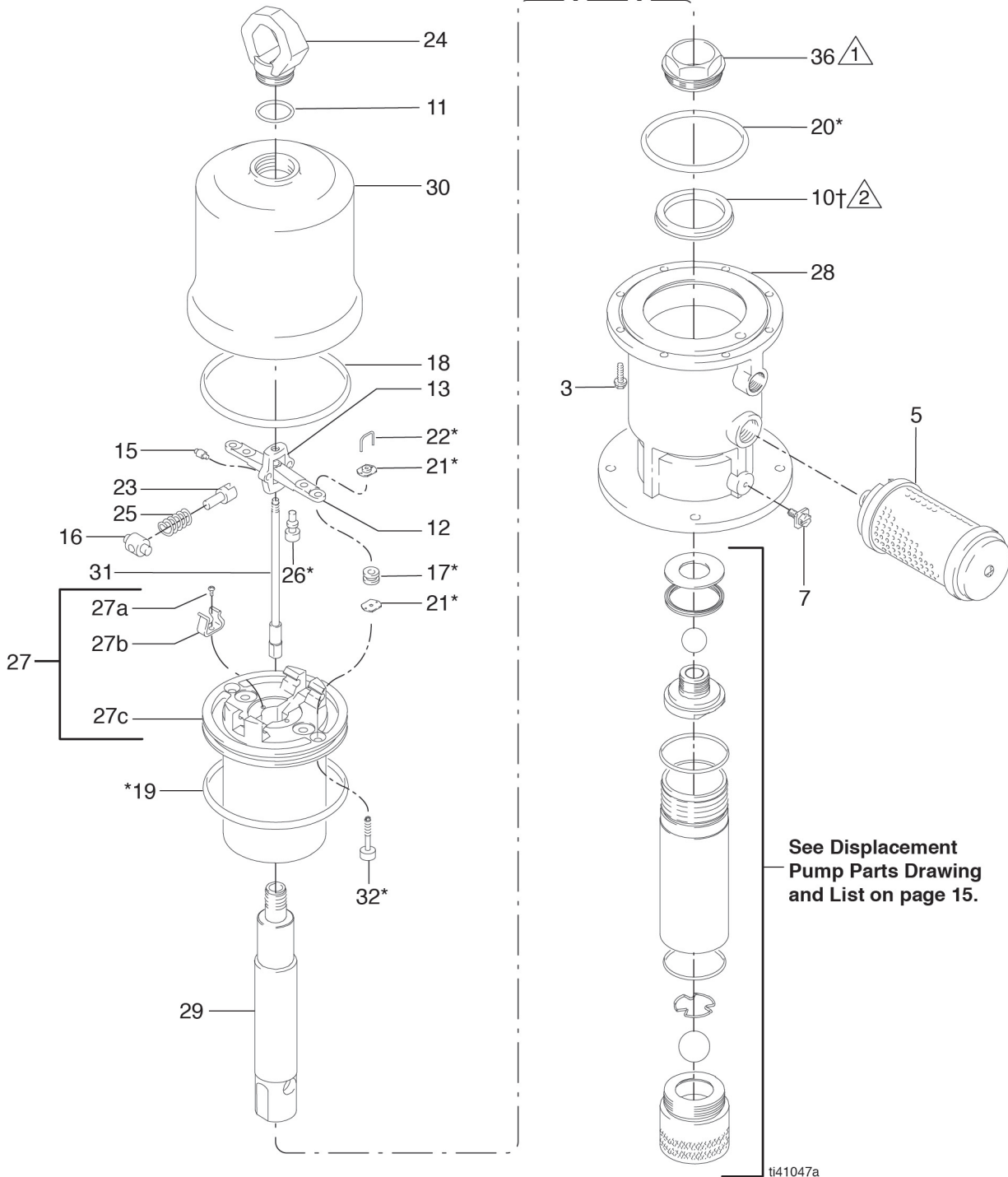

1 Torque to 30 to 40 ft-lb (41 to 54 N.m).

2 Lips must face down.

Parts List

Ref.	Part	Description	Qty.
3	101578	SCREW, cap, hex hd	8
5	102656	MUFFLER, air exhaust	1
7	116343	SCREW, ground	1
10†	113345	SEAL, u-cup	1
11	156698	PACKING, o-ring	1
12	158359	ACTUATOR, air valve	1
13	158360	YOKE, trip rod	1
15	158362	PIN, toggle	2
16	158364	PIN, pivot	2
17*	158367	GROMMET, inlet valve	2
18	158377	PACKING, ring seal	1
19*	158378	PACKING, o-ring	1
20*	158379	PACKING, o-ring	1
21*	160261	NUT, valve	4
22*	160618	WIRE, lock	2
23	160623	ARM, toggle	2
24	190929	RING, lift	1
25	167585	SPRING, helical compression	2
26*	170709	POPPET, exhaust valve	2
27	207391	PISTON, includes items 27 a to 27c (also includes 207385 Repair Kit when ordered as a new replacement part)	1
27a	102975	SCREW, rd hd mach; 6 - 32x 1/4 in.	2
27b	158361	CLIP, spring	2
27c		BARE PISTON (no sold separately)	1
28	190927	BASE, air motor	1
29	193799	ROD, piston	1
30	15E954	CYLINDER, air motor	1
31	207150	ROD, trip	1
32*	236079	POPPET, inlet valve	2
33	119344	LABEL, designation	1
35▲	290259	LABEL, warning	1
36	190930	BEARING, throat	1

† *Parts included in Pump Repair Kit 238225 (purchase separately).*

* *Parts included in Air Motor Repair Kit 207385 (purchase separately).*

▲ *Replacement safety labels, tags, and cards are available at no cost.*

Performance Charts

To find Fluid Outlet Pressure (psi/bar) at a specific fluid flow (gpm/lpm) and operating air pressure (psi/bar):

1. Locate desired fluid flow along the bottom of the chart.
2. Follow vertical line up to the point of intersection with selected fluid outlet pressure curve.
3. Align point on curve with vertical scale on left side of the chart to read fluid outlet pressure

Test Conditions: Pump tested with AW-32 oil at 75°F (24°C)

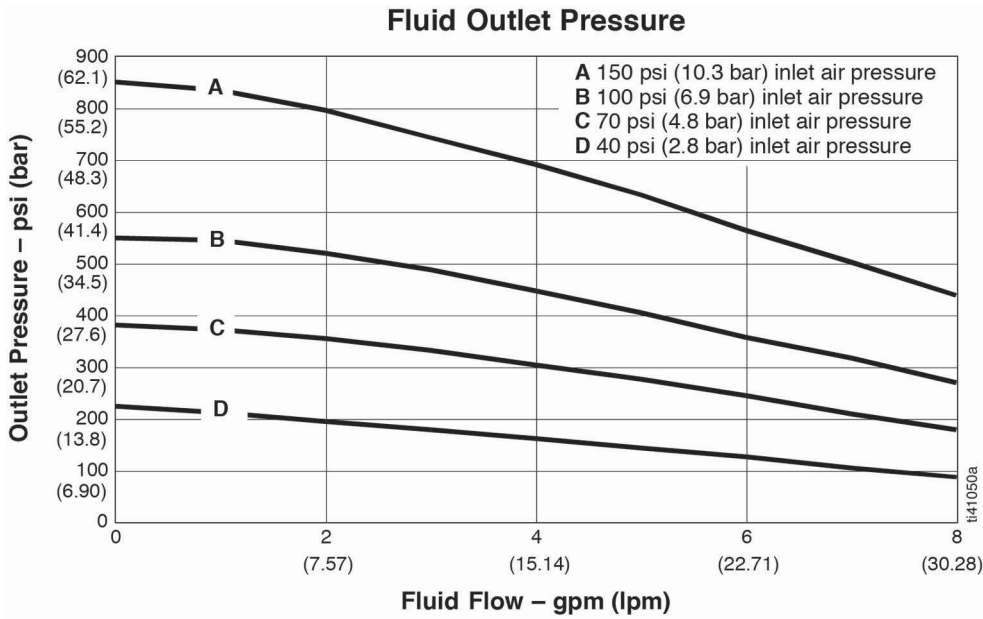

To find Pump Air Consumption (scfm or m³/min) at a specific fluid flow (gpm/lpm) and operating air pressure (psi/bar):

1. Locate desired fluid flow along the bottom of the chart.
2. Follow vertical line up to the point of intersection with selected air consumption curve.
3. Align point on curve with vertical scale on left side of the chart to read air consumption.

Test Conditions: Pump tested with AW-32 oil at 75°F (24°C)

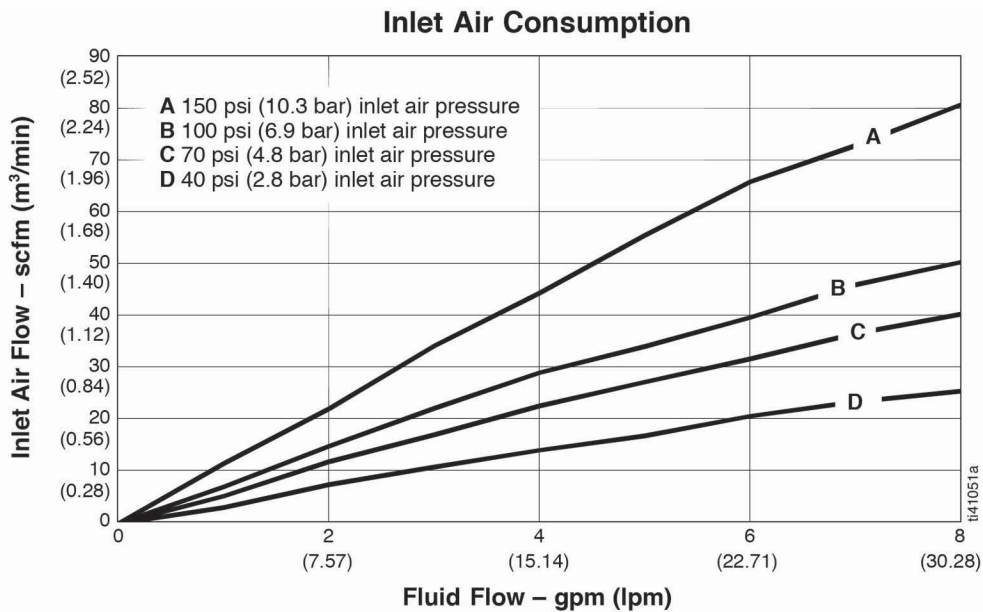

Dimensions

Model 238108 Pump, Series D

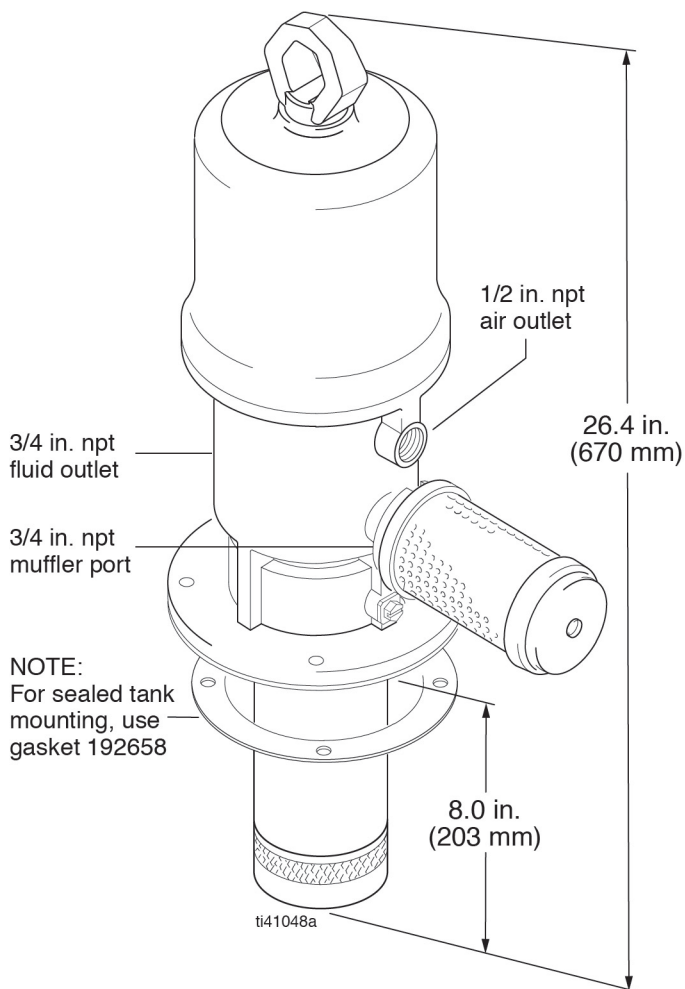

Mounting Hole Layout

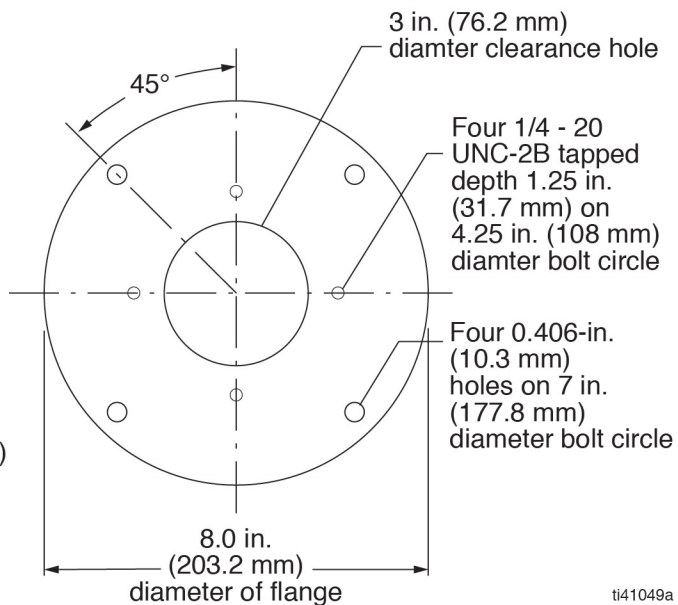

ti41049a

Technical Specifications

6:1 Fire-Ball 425 Pump		
	US	Metric
Maximum working pressure	1100 psi	7.58 MPa, 75.8 bar
Fluid pressure ratio	6:1	
Air operating range	40 to 180 psi	0.28 MPa to 1.24 MPa, 2.76 bar to 12.4 bar
Air consumption at 100 psi (0.7 MPa, 7 bar)	7 ft ³ /min per gallon pumped	0.051 m ³ /min per liter pumped
Pump cycles	14.5 per gallon	3.8 per liter
Maximum recommended pump speed	78 cycles/min.; 6 gpm (23 l/min.)	
Recommended speed for optimum pump life	15 to 25 cycles per min.	
Wetted Parts	Piston seals: polyurethane with nitrile spreader Rod seals: polyurethane with nitrile spreader Pump: aluminum, steel, polyurethane, nitrile	
Approximate weight	35 lbs	21 kg
Sound pressure level*	79.5 dBa	
*Sound pressure measured at 30 cycles per minute at 100 psi (0.7 MPa, 7 bar) air inlet pressure per ISO Standard 3744		
All trademarks or registered trademarks are the property of their respective owners.		

California Proposition 65

CALIFORNIA RESIDENTS

 **WARNING:** Cancer and reproductive harm – www.P65warnings.ca.gov.

Graco Standard Warranty

Graco warrants all equipment referenced in this document which is manufactured by Graco and bearing its name to be free from defects in material and workmanship on the date of sale to the original purchaser for use. With the exception of any special, extended, or limited warranty published by Graco, Graco will, for a period of twelve months from the date of sale, repair or replace any part of the equipment determined by Graco to be defective. This warranty applies only when the equipment is installed, operated and maintained in accordance with Graco's written recommendations.

This warranty does not cover, and Graco shall not be liable for general wear and tear, or any malfunction, damage or wear caused by faulty installation, misapplication, abrasion, corrosion, inadequate or improper maintenance, negligence, accident, tampering, or substitution of non-Graco component parts. Nor shall Graco be liable for malfunction, damage or wear caused by the incompatibility of Graco equipment with structures, accessories, equipment or materials not supplied by Graco, or the improper design, manufacture, installation, operation or maintenance of structures, accessories, equipment or materials not supplied by Graco.

This warranty is conditioned upon the prepaid return of the equipment claimed to be defective to an authorized Graco distributor for verification of the claimed defect. If the claimed defect is verified, Graco will repair or replace free of charge any defective parts. The equipment will be returned to the original purchaser transportation prepaid. If inspection of the equipment does not disclose any defect in material or workmanship, repairs will be made at a reasonable charge, which charges may include the costs of parts, labor, and transportation.

THIS WARRANTY IS EXCLUSIVE, AND IS IN LIEU OF ANY OTHER WARRANTIES, EXPRESS OR IMPLIED, INCLUDING BUT NOT LIMITED TO WARRANTY OF MERCHANTABILITY OR WARRANTY OF FITNESS FOR A PARTICULAR PURPOSE.

Graco's sole obligation and buyer's sole remedy for any breach of warranty shall be as set forth above. The buyer agrees that no other remedy (including, but not limited to, incidental or consequential damages for lost profits, lost sales, injury to person or property, or any other incidental or consequential loss) shall be available. Any action for breach of warranty must be brought within two (2) years of the date of sale.

GRACO MAKES NO WARRANTY, AND DISCLAIMS ALL IMPLIED WARRANTIES OF MERCHANTABILITY AND FITNESS FOR A PARTICULAR PURPOSE, IN CONNECTION WITH ACCESSORIES, EQUIPMENT, MATERIALS OR COMPONENTS SOLD BUT NOT MANUFACTURED BY GRACO. These items sold, but not manufactured by Graco (such as electric motors, switches, hose, etc.), are subject to the warranty, if any, of their manufacturer. Graco will provide purchaser with reasonable assistance in making any claim for breach of these warranties.

In no event will Graco be liable for indirect, incidental, special or consequential damages resulting from Graco supplying equipment hereunder, or the furnishing, performance, or use of any products or other goods sold hereto, whether due to a breach of contract, breach of warranty, the negligence of Graco, or otherwise.

FOR GRACO CANADA CUSTOMERS

The Parties acknowledge that they have required that the present document, as well as all documents, notices and legal proceedings entered into, given or instituted pursuant hereto or relating directly or indirectly hereto, be drawn up in English. Les parties reconnaissent avoir convenu que la rédaction du présente document sera en Anglais, ainsi que tous documents, avis et procédures judiciaires exécutés, donnés ou intentés, à la suite de ou en rapport, directement ou indirectement, avec les procédures concernées.

Graco Information

For the latest information about Graco products, visit www.graco.com.

For patent information, see www.graco.com/patents.

TO PLACE AN ORDER, contact your Graco distributor or call to identify the nearest distributor.

Phone: 612-623-6928 **or Toll Free:** 1-800-533-9655, **Fax:** 612-378-359

All written and visual data contained in this document reflects the latest product information available at the time of publication. Graco reserves the right to make changes at any time without notice.

Original instructions. This manual contains English. MM 308608

Graco Headquarters: Minneapolis

International Offices: Belgium, China, Japan, Korea

GRACO INC. AND SUBSIDIARIES • P.O. BOX 1441 • MINNEAPOLIS MN 55440-1441 • USA
Copyright 1995, Graco Inc. All Graco manufacturing locations are registered to ISO 9001.

www.graco.com
Revision M, July 2022