

Vent Valve Kit Pressure Relief Valve Kit

308954E
EN

For air powered single-line parallel automatic lubrication systems.
For professional use only.



Model:

115121 - Vent Valve

115122 - Pressure Relief Valve



Important Safety Instructions
Read all warnings and instructions in this manual and in manual 308955. Save all instructions.

					
SKIN INJECTION HAZARD					
High-pressure fluid from dispensing device, hose leaks, or ruptured components will pierce skin. This may look like just a cut, but it is a serious injury that can result in amputation. Get immediate surgical treatment.					
<ul style="list-style-type: none"> • Do not point dispensing device at anyone or at any part of the body. • Do not put your hand over the fluid outlet. • Do not stop or deflect leaks with your hand, body, glove, or rag. • Follow the Pressure Relief Procedure when you stop dispensing and before cleaning, checking, or servicing equipment. • Tighten all fluid connections before operating the equipment. • Check hoses and couplings daily. Replace worn or damaged parts immediately. 					

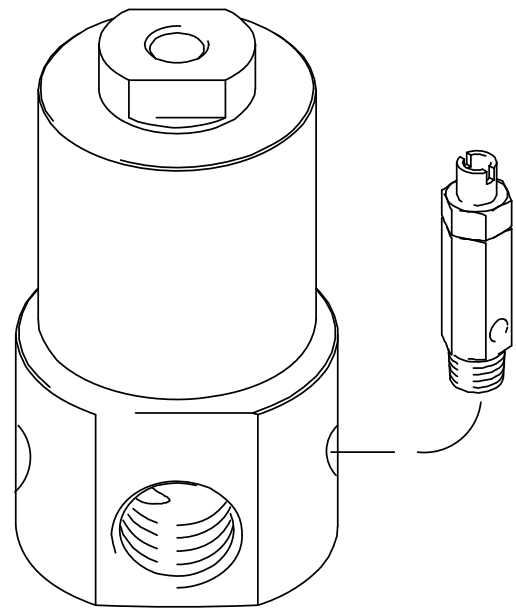

Pressure Relief Procedure



Follow the Pressure Relief Procedure whenever you see this symbol.

--	--	--	--	--	--	--

- This equipment stays pressurized until pressure is manually relieved. To help prevent serious injury from pressurized fluid, such as skin injection, splashing fluid and moving parts, follow the Pressure Relief Procedure when you stop spraying and before cleaning, checking, or servicing the equipment.
- To prevent system over pressurization, a pressure relief valve (PN 115122) must be used in conjunction with all vent valve installations. Failure to comply with this warning could result in serious injury.

1. Disconnect power from Lubrication Controller.
2. Disable air supply to pump by one of the following means:
 - Close bleed-type air valve.
 - Disconnect quick disconnect air coupler from tee on vent valve.

Parts

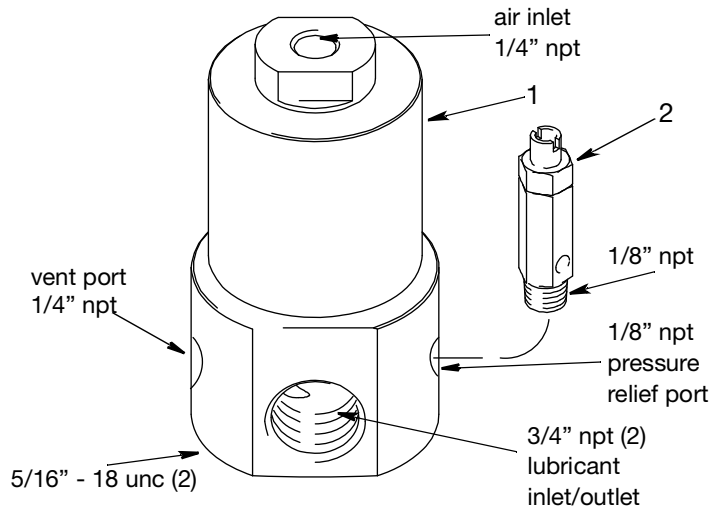
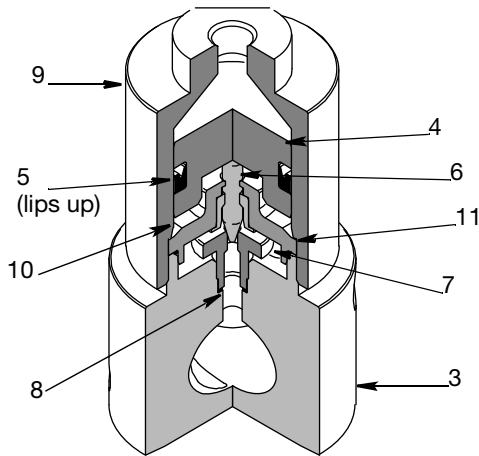

Ref No.	Description	Qty
1	VENT VALVE (PN 115121)	1
2	PRESSURE RELIEF VALVE (PN 115122)	1
3	VENT VALVE BODY	1
4	PISTON (PN 114922)	1
5◆	AIR PISTON PACKING (lips up) (PN 114926)	1
6◆	NEEDLE	1
7◆	VALVE SEAT	1
8◆	CHECK SEAT GASKET	1

Ref No.	Description	Qty
9	AIR CYLINDER (PN 114921)	1
10◆	O-RING, fluoroelastomer	1
11◆	PACKING RETAINER	1

◆ Included in Vent Valve Repair Kit 241571

Technical Data

Vent Valve - 115121		
	US	Metric
Maximum Air Pressure	120 psi	.08 MPa, 8 bar
Maximum Fluid Pressure	3800 psi	26 MPa, 262 bar
Fluid-side wetted parts	Carbon Steel, Fluoroelastomer	
Air-side wetted parts	Aluminum, buna-N	
Recommended fluids	Lubricant N.L.G.I. grade #2 or lighter	
Dimensions	Height: 4.25 in., Width: 2.25 in.	Height: 10.79 cm., Width: 5.715 cm.

Pressure Relief Valve - 115122		
Opening Pressure	4000 psi	28 MPa, 276 bar
Threaded connection size	1/8 npt (m)	
Wetted Parts	Carbon Steel	
Recommended Fluids	Grease grades N.L.G.I. #2 or lighter	
Dimensions	Height: 2 in., Width: 1/2 in.	Height: 5.08 cm., Width: 1.27 cm.

Graco Standard Warranty

Graco warrants all equipment referenced in this document which is manufactured by Graco and bearing its name to be free from defects in material and workmanship on the date of sale to the original purchaser for use. With the exception of any special, extended, or limited warranty published by Graco, Graco will, for a period of twelve months from the date of sale, repair or replace any part of the equipment determined by Graco to be defective. This warranty applies only when the equipment is installed, operated and maintained in accordance with Graco's written recommendations.

This warranty does not cover, and Graco shall not be liable for general wear and tear, or any malfunction, damage or wear caused by faulty installation, misapplication, abrasion, corrosion, inadequate or improper maintenance, negligence, accident, tampering, or substitution of non-Graco component parts. Nor shall Graco be liable for malfunction, damage or wear caused by the incompatibility of Graco equipment with structures, accessories, equipment or materials not supplied by Graco, or the improper design, manufacture, installation, operation or maintenance of structures, accessories, equipment or materials not supplied by Graco.

This warranty is conditioned upon the prepaid return of the equipment claimed to be defective to an authorized Graco distributor for verification of the claimed defect. If the claimed defect is verified, Graco will repair or replace free of charge any defective parts. The equipment will be returned to the original purchaser transportation prepaid. If inspection of the equipment does not disclose any defect in material or workmanship, repairs will be made at a reasonable charge, which charges may include the costs of parts, labor, and transportation.

THIS WARRANTY IS EXCLUSIVE, AND IS IN LIEU OF ANY OTHER WARRANTIES, EXPRESS OR IMPLIED, INCLUDING BUT NOT LIMITED TO WARRANTY OF MERCHANTABILITY OR WARRANTY OF FITNESS FOR A PARTICULAR PURPOSE.

Graco's sole obligation and buyer's sole remedy for any breach of warranty shall be as set forth above. The buyer agrees that no other remedy (including, but not limited to, incidental or consequential damages for lost profits, lost sales, injury to person or property, or any other incidental or consequential loss) shall be available. Any action for breach of warranty must be brought within two (2) years of the date of sale.

GRACO MAKES NO WARRANTY, AND DISCLAIMS ALL IMPLIED WARRANTIES OF MERCHANTABILITY AND FITNESS FOR A PARTICULAR PURPOSE, IN CONNECTION WITH ACCESSORIES, EQUIPMENT, MATERIALS OR COMPONENTS SOLD BUT NOT MANUFACTURED BY GRACO. These items sold, but not manufactured by Graco (such as electric motors, switches, hose, etc.), are subject to the warranty, if any, of their manufacturer. Graco will provide purchaser with reasonable assistance in making any claim for breach of these warranties.

In no event will Graco be liable for indirect, incidental, special or consequential damages resulting from Graco supplying equipment hereunder, or the furnishing, performance, or use of any products or other goods sold hereto, whether due to a breach of contract, breach of warranty, the negligence of Graco, or otherwise.

FOR GRACO CANADA CUSTOMERS

The Parties acknowledge that they have required that the present document, as well as all documents, notices and legal proceedings entered into, given or instituted pursuant hereto or relating directly or indirectly hereto, be drawn up in English. Les parties reconnaissent avoir convenu que la rédaction du présente document sera en Anglais, ainsi que tous documents, avis et procédures judiciaires exécutés, donnés ou intentés, à la suite de ou en rapport, directement ou indirectement, avec les procédures concernées.

Graco Information

For the latest information about Graco products, visit www.graco.com.

TO PLACE AN ORDER, contact your Graco distributor or call to identify the nearest distributor.

Phone: 612-623-6928 or **Toll Free:** 1-800-533-9655, **Fax:** 612-378-3590

*All written and visual data contained in this document reflects the latest product information available at the time of publication.
Graco reserves the right to make changes at any time without notice.*

For patent information, see www.graco.com/patents.

Original instructions. This manual contains English. MM 308954

Graco Headquarters: Minneapolis
International Offices: Belgium, China, Japan, Korea

GRACO INC. AND SUBSIDIARIES • P.O. BOX 1441 • MINNEAPOLIS MN 55440-1441 • USA

Copyright 1999, Graco Inc. All Graco manufacturing locations are registered to ISO 9001.

www.graco.com

Revision E, February 2022