

Two-Ball NXT[®] 1000cc Pumps

311833G

EN

Designed for low pressure, medium volume circulation of finishing materials.

For professional use only.

**Models P06DCK, P06ECK, P06LCK, P06MCK,
P06DSG*, P06ESG*, P06LSG*, P06MSG***

620 psi (4.2 MPa, 42.7 bar) Maximum Working Pressure

100 psi (0.69 MPa, 6.9 bar) Maximum Air Inlet Pressure

* Uses plate check valves instead of ball check valves.

Models P10DCK, P10ECK, P10LCK, P10MCK, P10LCS

1180 psi (8.14 MPa, 81.4 bar) Maximum Working Pressure

100 psi (0.69 MPa, 6.9 bar) Maximum Air Inlet Pressure



Important Safety Instructions

Read all warnings and instructions in **Operation** manual.
Save these instructions.

See page 2 for **Table of Contents**.

Patent Pending

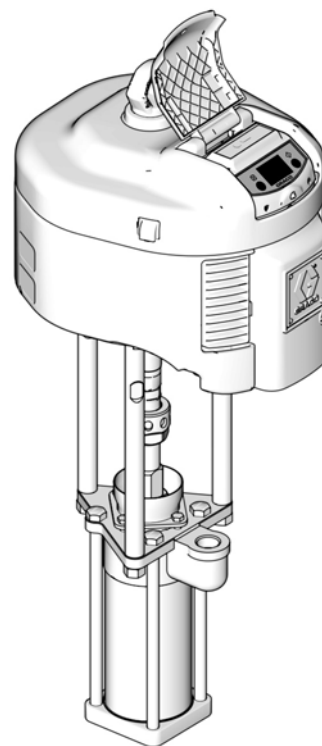

ti8377b



Contents

Pumps with NXT® Air Motors Part No. Matrix	3	Repair	12
Warnings	4	Required Tools	12
Installation	6	Disconnect the Lower	12
Grounding	6	Reconnect the Lower	13
Accessories	6	Models	
Flush Before Using Equipment	7	P06DCK, P06ECK, P06LCK, P06MCK,	
Operation	8	P10DCK, P10ECK, P10LCK, P10MCK,	
Pressure Relief Procedure	8	P10LCS	14
Maintenance	9	Parts List	15
Shutdown	9	Dimensions	16
Care of the Pump	9	Pump Mounting Hole Diagram	17
Flushing	9	Technical Data	18
Lubrication	9	Graco Standard Warranty	20
Troubleshooting	11	Graco Information	20





Pumps with NXT® Air Motors Part No. Matrix

Check your pump's identification plate (ID) for the 6-digit part number of your pump. Use the following matrix to define the construction of your pump, based on the six digits. For example, Pump Part No. **P 0 6 M S G** represents the pump (**P**), pressure ratio (**0 6** :1), low noise exhaust motor with DataTrak™ (**M**), stainless steel construction (**S**) PTFE/PTFE packing configuration (**G**). To order replacement parts, see **Parts List** section starting on page 15. The digits in the matrix do not correspond to the Ref. Nos. in the Parts drawings and lists.



P	0 6	M			S		G	
First Digit	Second and Third Digit	Fourth Digit			Fifth Digit		Sixth Digit	
		Pressure Ratio (xx:1)	Exhaust	Communication		Material		Packings
P (pumps)	06	D	De-icing	none	C	Carbon Steel	G	PTFE / PTFE
	10	E	De-icing	DataTrak	S	Stainless Steel	K	UHMW / Leather
		L	Low Noise	none			S	Severe Duty (PTFE/UHMWP)
		M	Low Noise	DataTrak				

Warnings

The following warnings are for the setup, use, grounding, maintenance, and repair of this equipment. The exclamation point symbol alerts you to a general warning and the hazard symbol refers to procedure-specific risk. Refer back to these warnings. Additional, product-specific warnings may be found throughout the body of this manual where applicable.

 WARNING	
	<p>EQUIPMENT MISUSE HAZARD</p> <p>Misuse can cause death or serious injury.</p> <ul style="list-style-type: none"> • Do not operate the unit when fatigued or under the influence of drugs or alcohol. • Do not exceed the maximum working pressure or temperature rating of the lowest rated system component. See Technical Data in all equipment manuals. • Use fluids and solvents that are compatible with equipment wetted parts. See Technical Data in all equipment manuals. Read fluid and solvent manufacturer's warnings. For complete information about your material, request MSDS forms from distributor or retailer. • Check equipment daily. Repair or replace worn or damaged parts immediately with genuine manufacturer's replacement parts only. • Do not alter or modify equipment. • Use equipment only for its intended purpose. Call your distributor for information. • Route hoses and cables away from traffic areas, sharp edges, moving parts, and hot surfaces. • Do not kink or over bend hoses or use hoses to pull equipment. • Keep children and animals away from work area. • Comply with all applicable safety regulations.
	<p>TOXIC FLUID OR FUMES HAZARD</p> <p>Toxic fluids or fumes can cause serious injury or death if splashed in the eyes or on skin, inhaled, or swallowed.</p> <ul style="list-style-type: none"> • Read MSDS's to know the specific hazards of the fluids you are using. • Store hazardous fluid in approved containers, and dispose of it according to applicable guidelines. • Always wear impervious gloves when spraying or cleaning equipment.
	<p>FIRE AND EXPLOSION HAZARD</p> <p>Flammable fumes, such as solvent and paint fumes, in work area can ignite or explode. To help prevent fire and explosion:</p> <ul style="list-style-type: none"> • Use equipment only in well ventilated area. • Eliminate all ignition sources; such as pilot lights, cigarettes, portable electric lamps, and plastic drop cloths (potential static arc). • Keep work area free of debris, including solvent, rags and gasoline. • Do not plug or unplug power cords, or turn power or light switches on or off when flammable fumes are present. • Ground all equipment in the work area. See Grounding instructions. • Use only grounded hoses. • Hold gun firmly to side of grounded pail when triggering into pail. • If there is static sparking or you feel a shock, stop operation immediately. Do not use equipment until you identify and correct the problem. • Keep a working fire extinguisher in the work area.

WARNING

	<p>PRESSURIZED EQUIPMENT HAZARD</p> <p>Fluid from the gun/dispense valve, leaks, or ruptured components can splash in the eyes or on skin and cause serious injury.</p> <ul style="list-style-type: none"> • Follow Pressure Relief Procedure in this manual, when you stop spraying and before cleaning, checking, or servicing equipment. • Tighten all fluid connections before operating the equipment. • Check hoses, tubes, and couplings daily. Replace worn or damaged parts immediately.
	<p>MOVING PARTS HAZARD</p> <p>Moving parts can pinch or amputate fingers and other body parts.</p> <ul style="list-style-type: none"> • Keep clear of moving parts. • Do not operate equipment with protective guards or covers removed. • Pressurized equipment can start without warning. Before checking, moving, or servicing equipment, follow the Pressure Relief Procedure in this manual. Disconnect power or air supply.
	<p>SKIN INJECTION HAZARD</p> <p>High-pressure fluid from dispense valve, hose leaks, or ruptured components will pierce skin. This may look like just a cut, but it is a serious injury that can result in amputation. Get immediate surgical treatment.</p> <ul style="list-style-type: none"> • Do not point dispense valve at anyone or at any part of the body. • Do not put your hand over the end of the dispense nozzle. • Do not stop or deflect leaks with your hand, body, glove, or rag. • Follow Pressure Relief Procedure in this manual, when you stop spraying and before cleaning, checking, or servicing equipment.

Installation

Grounding

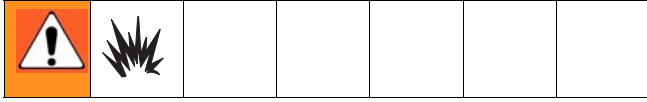

The equipment must be grounded. Grounding reduces the risk of static and electric shock by providing an escape wire for the electrical current due to static build up or in the event of a short circuit.

Pump: Use the ground screw (X) and lockwasher on the motor to attach ground wire 244524 (Y). Tighten the screw securely. Connect the other end of the ground wire to a true earth ground.

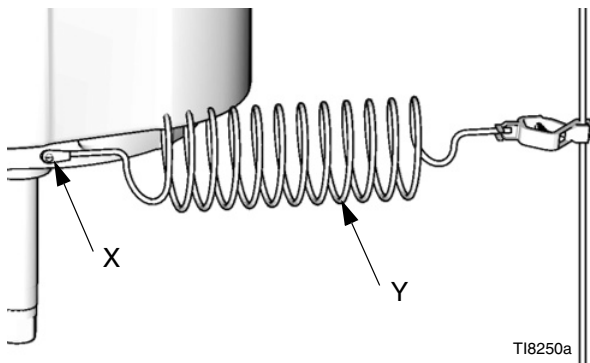

FIG. 1

Air and fluid hoses: use only electrically conductive hoses, with a maximum of 500 ft. (150 m) combined hose length to ensure grounding continuity. Check electrical resistance of hoses. If total resistance to ground exceeds 29 megohms, replace hose immediately.

Air compressor: follow manufacturer's recommendations.

Spray gun: ground through connection to a properly grounded fluid hose and pump.

Fluid supply container: follow local code.

Object being sprayed: follow local code.

Solvent pails used when flushing: follow local code. Use only conductive metal pails, placed on a grounded surface. Do not place the pail on a nonconductive surface, such as paper or cardboard, which interrupts grounding continuity.





To maintain grounding continuity when flushing or relieving pressure: hold metal part of the spray gun firmly to the side of a grounded metal pail, then trigger the gun.

Accessories

 Accessory Air Control Kits are available for the NXT Air Motor. The kits include a master air valve, air regulator, and filter. Order the kit separately. See manual 311239 for more information.

Air Line

- **Bleed-type master air valve:** required in your system to relieve air trapped between it and the air motor when the valve is closed.

							
Trapped air can cause the pump to cycle unexpectedly, which could result in serious injury from splashing or moving parts.							

Be sure the valve is easily accessible from the pump and located downstream from the air regulator.

- **Pump air regulator:** to control pump speed and outlet pressure. Locate it close to the pump.
- **Air line filter:** removes harmful dirt and moisture from compressed air supply.
- **Second bleed-type air valve:** isolates air line accessories for servicing. Locate upstream from all other air line accessories.
- **Gun air regulator:** controls air pressure to the gun.

Fluid Line

- **Fluid filter:** with a 60 mesh (250 micron) stainless steel element to filter particles from the fluid as it leaves the pump.

- **Fluid drain valve:** required in your system, to relieve fluid pressure in the hose and gun.
- **Fluid shutoff valve:** shuts off fluid flow.
- **Fluid pressure regulator:** for more precise adjustment of the fluid pressure.
- **Gun or valve:** to dispense fluid.
- **Fluid line swivel:** for easier gun movement.
- **Suction kit:** enables the pump to draw fluid from a container.

Flush Before Using Equipment

The equipment was tested with lightweight oil, which is left in the fluid passages to protect parts. To avoid contaminating your fluid with oil, flush the equipment with a compatible solvent before using the equipment. See **Flushing**, page 9.

Operation

Pressure Relief Procedure

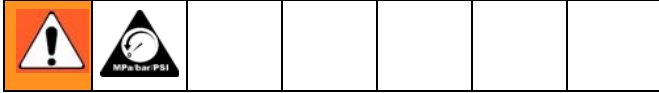

1. Engage trigger lock.
2. Close the bleed-type master air valve.
3. Disengage the trigger lock.
4. Hold a metal part of the gun firmly to a grounded metal pail. Trigger the gun to relieve pressure.
5. Engage the trigger lock.
6. Open all fluid drain valves in the system, having a waste container ready to catch drainage. Leave drain valve(s) open until you are ready to spray again.
7. If you suspect the spray tip or hose is clogged or that pressure has not been fully relieved after following the steps above, **VERY SLOWLY** loosen tip guard retaining nut or hose end coupling to relieve pressure gradually, then loosen completely. Clear hose or tip obstruction.

Maintenance

Shutdown



To reduce the risk of serious injury whenever you are instructed to relieve pressure, always follow the Pressure Relief Procedure on page 8.

Always stop the pump at the bottom of its stroke to prevent fluid from drying on the rod and damaging the throat packings.

Relieve the pressure.

Care of the Pump

On stainless steel models, check the tightness of the packing retainer screws (A) weekly. The screws should be tight enough to stop leakage, but no tighter. Always relieve the pressure before adjusting the packing retainer screws. See FIG. 2. On carbon steel models, tighten wet cup (B) using wet cup wrench.

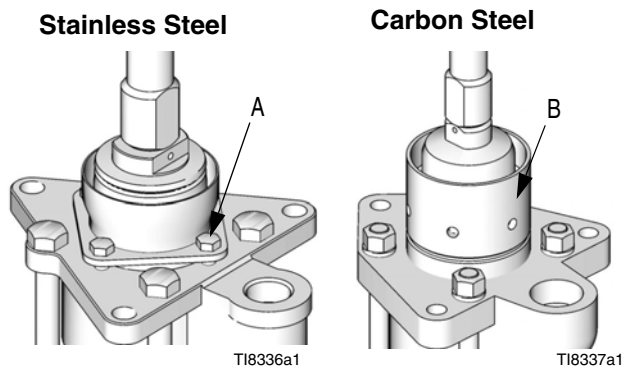
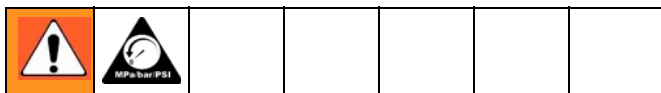

FIG. 2

Flushing

If you are pumping fluid which dries, hardens, or sets up, flush the system with a compatible solvent as often as necessary to prevent build up of dried fluid in the pump or hoses.



To reduce the risk of serious injury whenever you are instructed to relieve pressure, always follow the Pressure Relief Procedure on page 8.

To reduce risk of static sparking or splashing in the eyes or on the skin, relieve the pressure and remove the spray tip before flushing. Start the pump. Hold a metal part of the gun firmly to the side of a grounded metal pail and use the lowest possible fluid pressure during flushing. When flushing is complete, relieve the pressure.

Lubrication





To reduce the risk of serious injury whenever you are instructed to relieve pressure, always follow the Pressure Relief Procedure on page 8.

The accessory air line lubricator provides automatic air motor lubrication. For daily, manual lubrication, relieve the pressure, disconnect the regulator, place about 15 drops of light machine oil in the pump air inlet, reconnect the regulator, and turn on the air supply to blow oil into the motor.





A series of 25 horizontal lines spaced evenly down the page, providing a template for handwritten notes or a checklist.

Troubleshooting

						
<p>To reduce the risk of serious injury whenever you are instructed to relieve pressure, always follow the Pressure Relief Procedure on page 8.</p>						

1. Relieve the pressure.

2. Check all possible problems and solutions before disassembling pump.

						
<p>Never operate the pump with the air motor shield removed. Moving parts can pinch or amputate your fingers or other body parts. When the pump is operating, the air motor piston (located behind the air motor shield) moves.</p>						

PROBLEM	CAUSE	SOLUTION
Pump does not operate, or no fluid flow.	Loose or broken pump parts.	Disassemble, check, repair.
	Restricted line or inadequate air supply.	Clear, increase.
	Exhausted fluid supply.	Refill and prime.
	Clogged fluid hoses.	Clean, or replace.
	Damaged air motor.	Repair.
Pump operates, but output is low.	Insufficient air supply.	Increase.
	Exhausted fluid supply.	Refill and prime.
	Obstructed gun or dispensing valve.	Clear.
	Packing retainer needs adjustment.	Loosen or tighten screws as necessary.
	Damaged fluid pump packings.	Replace.
Erratic or accelerated operation.	Held open or worn piston intake valve.	Repair.
	Exhausted fluid supply.	Refill and prime.
	Fluid intake or piston valve worn.	Repair.

Repair

Required Tools

- Set of socket wrenches
- Set of adjustable wrenches
- 24 in. adjustable wrench
- Torque wrench
- Rubber mallet
- Arbor press
- Soft wooden block (approx. 1 square foot in size)
- Large vise, with soft jaws
- Thread lubricant
- Anti-seize lubricant 222955
- Loctite® 2760™ or equivalent

5. Hold the tie rod flats with a wrench to keep the rods (6) from turning. Unscrew the nuts (7). Remove the lower (2).
6. To service the lower, refer to manual 311716 or 311717, supplied. To service the air motor, refer to the separate motor manual, supplied.

Disconnect the Lower

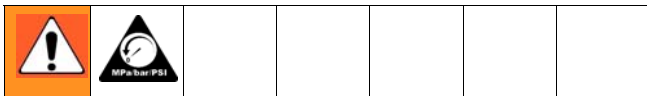

1. Flush the pump, if possible. Stop the pump at the bottom of its stroke. Relieve the pressure, page 8.
2. Disconnect the air hose.
3. Hold the fluid outlet fitting with a wrench to keep it from loosening while you disconnect the fluid hose. See FIG. 3.

CAUTION

Use at least two people when lifting, moving, or disconnecting the pump. If disconnecting the lower, be sure to securely brace the pump, or have two people hold it while another disconnects it.

 Before disconnecting the lower (2) from the motor (1), be sure to note the relative position of the pump's fluid outlet to the air inlet of the motor. If the motor does not require servicing, leave it attached to its mounting.

4. Unscrew the coupling nut (3) from the connecting rod adapter (5). Remove the coupling collars; do not lose or drop them. See FIG. 3.

Reconnect the Lower

1. Screw the connecting rod adapter (5) to the air motor shaft. Torque as noted in FIG. 3.
2. Screw the tie rods (6) into the air motor (1). Using a wrench on the tie rod flats, torque as noted.
3. Make sure the coupling nut (3) and coupling collars (4) are in place on the displacement rod.
4. Use at least two people to hold the lower while another reconnects it to the motor (see the **CAUTION**, page 12). Orient the pump's fluid outlet to the air inlet as noted under **Disconnect the Lower**. Place the lower (2) on the tie rods (6).
5. Screw the nuts (7) onto the tie rods (6) and torque as noted in FIG. 3.
6. Screw the coupling nut (3) onto the connecting rod adapter (5) loosely. Hold the connecting rod adapter flats with a wrench to keep it from turning. Use an adjustable wrench to tighten the coupling nut. Torque as noted in FIG. 3.
7. Reconnect all hoses. Reconnect the ground wire if it was disconnected. Fill the wet-cup 1/3 full of Graco Throat Seal Liquid or compatible solvent.
8. Turn on the air power supply. Run the pump slowly to ensure that it operates properly.

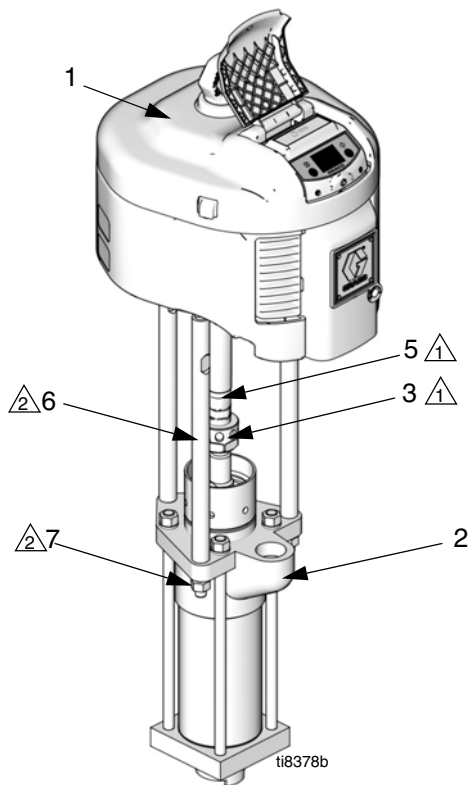

 Torque to 196-210 N•m (145-155 ft-lb)

 Torque to 68-81 N•m (50-60 ft-lb)

FIG. 3. Reconnect the Lower

**Models P06DSG, P06ESG,
P06LSG, P06MSG**

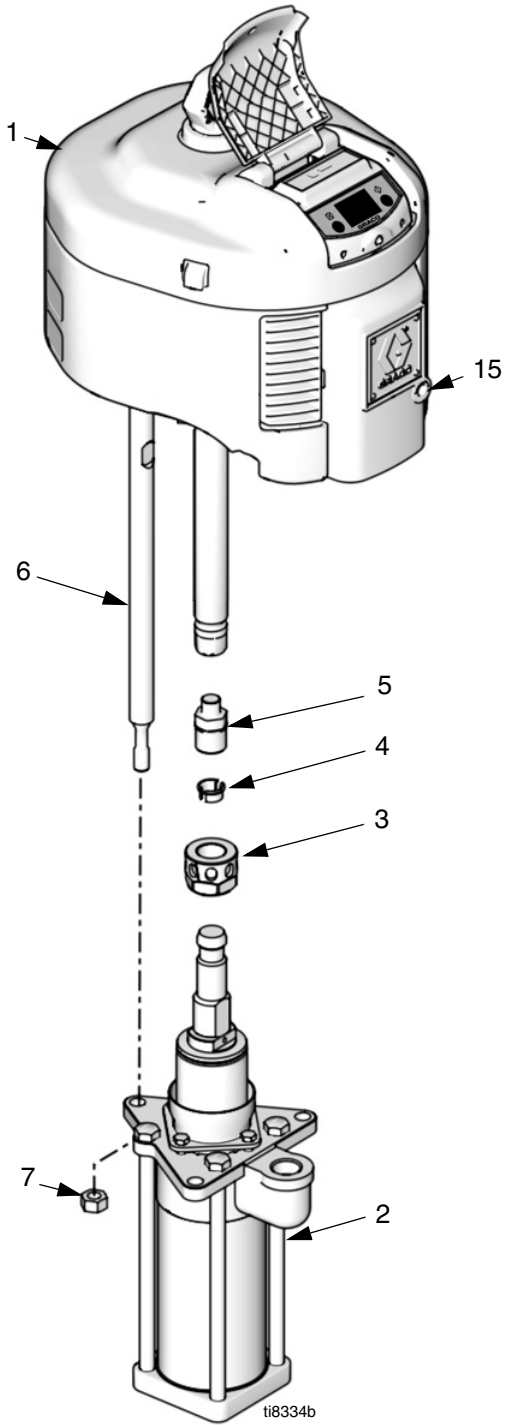

FIG. 4

**Models
P06DCK, P06ECK, P06LCK,
P06MCK, P10DCK, P10ECK,
P10LCK, P10MCK, P10LCS**

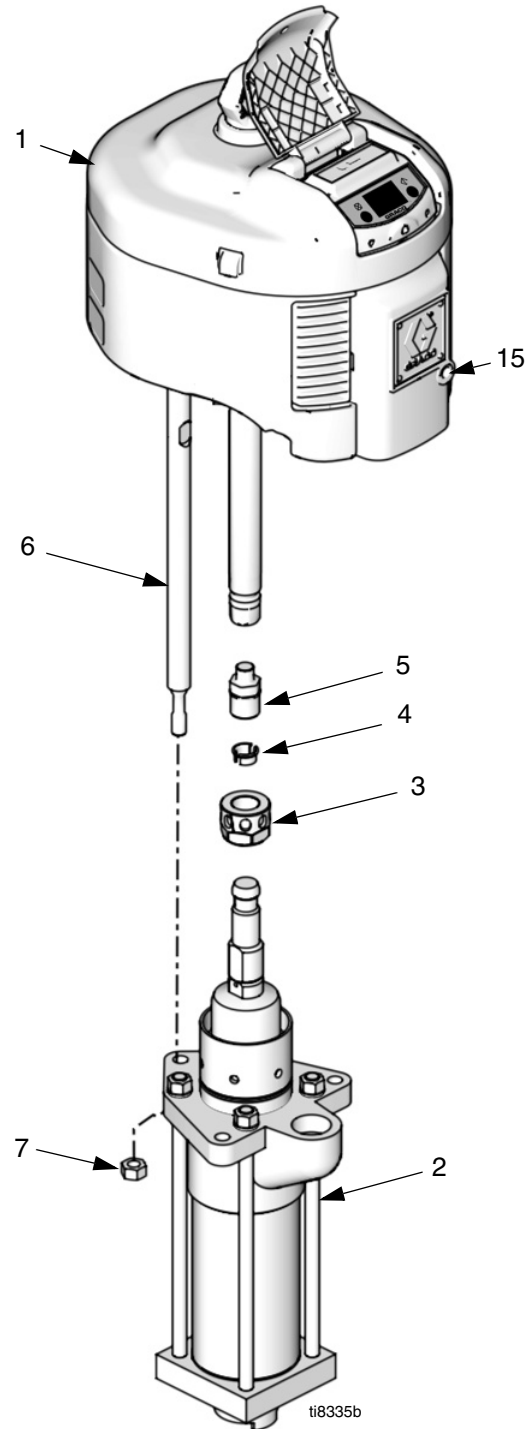

FIG. 5

Parts List

Ref.	Description	P06DSG	P06ESG	P06LSG	P06MSG	Qty.
1	MOTOR, 3400, de-icing std; see manual 311238	N34DN0				1
	MOTOR, 3400, de-icing datatrak; see manual 311238		N34DT0			1
	MOTOR, 3400, low noise std; see manual 311238			N34LN0		1
	MOTOR, 3400, low noise datatrak; see manual 311238				N34LT0	1
2	PUMP; see manual 311716	253596	253596	253596	253596	1
3	NUT, coupling	184096	184096	184096	184096	1
4	COLLAR, coupling	184130	184130	184130	184130	2
5	ADAPTER	15H371	15H371	15H371	15H371	1
6	ROD, tie	15H562	15H562	15H562	15H562	3
7	NUT, lock	101712	101712	101712	101712	3
15	PLUG, pipe, round	120588	120588	120588	120588	1
17	WRENCH, wet cup	184278	184278	184278	184278	1

Ref.	Description	P06DCK	P06ECK	P06LCK	P06MCK	Qty.
1	MOTOR, 3400, de-icing std; see manual 311238	N34DN0				1
	MOTOR, 3400, de-icing datatrak; see manual 311238		N34DT0			1
	MOTOR, 3400, low noise std; see manual 311238			N34LN0		1
	MOTOR, 3400, low noise datatrak; see manual 311238				N34LT0	1
2	PUMP; see manual 311717	253597	253597	253597	253597	1
3	NUT, coupling	184096	184096	184096	184096	1
4	COLLAR, coupling	184130	184130	184130	184130	2
5	ADAPTER	15H371	15H371	15H371	15H371	1
6	ROD, tie	15H562	15H562	15H562	15H562	3
7	NUT, lock	101712	101712	101712	101712	3
15	PLUG, pipe, round	120588	120588	120588	120588	1
17	WRENCH, wet cup	184278	184278	184278	184278	1

Ref.	Description	P10DCK	P10ECK	P10LCK	P10MCK	P10LCS	Qty.
1	MOTOR, 6500, de-icing std; see manual 311238	N65DN0					1
	MOTOR, 6500, de-icing datatrak; see manual 311238		N65DT0				1
	MOTOR, 6500, low noise std; see manual 311238			N65LN0		N65LN0	1
	MOTOR, 6500, low noise datatrak; see manual 311238				N65LT0		1
2	PUMP; see manual 311717	253597	253597	253597	253597	L10XCS	1
3	NUT, coupling	184096	184096	184096	184096	184096	1
4	COLLAR, coupling	184130	184130	184130	184130	184130	2
5	ADAPTER	15H371	15H371	15H371	15H371	15H371	1
6	ROD, tie	15H562	15H562	15H562	15H562	15H562	3
7	NUT, lock	101712	101712	101712	101712	101712	3
15	PLUG, pipe, round	120588	120588	120588	120588	120588	1

Dimensions

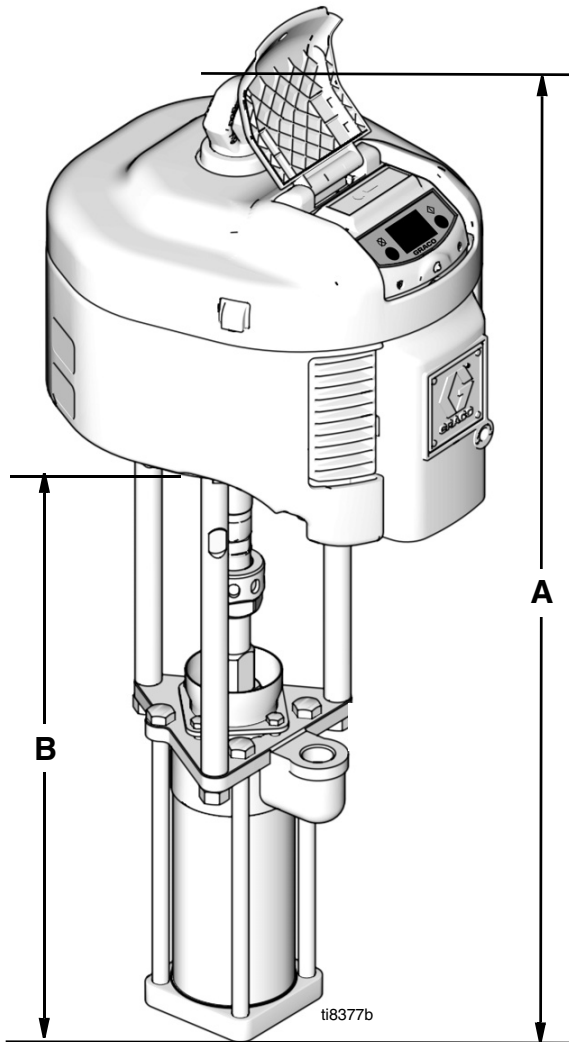

Pump Model	A		Approx. Weight
	in. (mm)	in. (mm)	
P06_SG	41.6 (1055)	28.0 (711)	113 (51)
P06_CK	41.6 (1055)	28.0 (711)	113 (51)
P10_CK	41.6 (1055)	28.0 (711)	132 (62)
P10_CS	41.6 (1055)	28.0 (711)	132 (62)

Pump Mounting Hole Diagram

NXT Model 3400

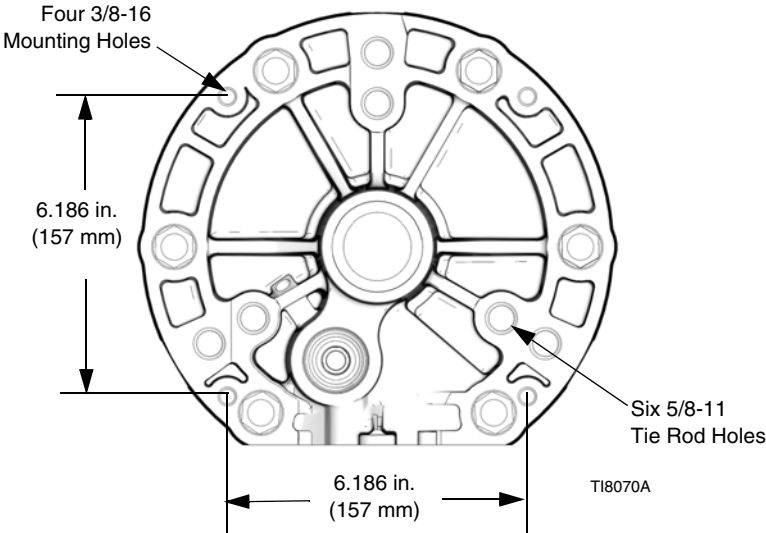

NXT Model 6500

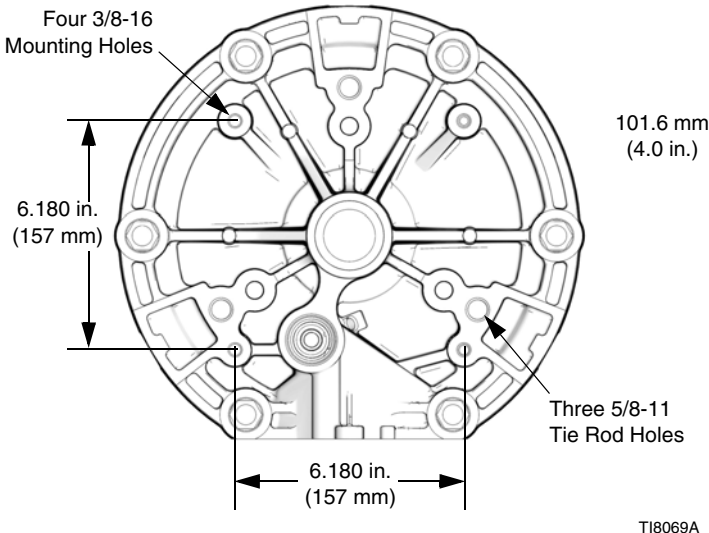

Technical Data

Model	Maximum Working Pressure psi (MPa, bar)	Maximum Air Input Pressure psi (MPa, bar)	Air Consumption	Fluid Flow at 60 cycles per minute gpm (lpm)
All P06 ___ Models	620 (4.2, 42)	100 (0.69, 6.9)	See Performance Chart	17.4 (65.8)
All P10 ___ Models	1180 (8.14, 81.4)	100 (0.69, 6.9)		17.4 (65.8)

See air motor manual 311238 for sound pressure levels.

Pump Performance Charts

Fluid Outlet Pressure

To find fluid outlet pressure (MPa/bar/psi) at a specific flow (lpm/gpm) and operating pressure (A/B/C):

1. Locate desired flow at bottom of chart.
2. Follow vertical line up to intersection with selected operating pressure curve (solid line). Follow left to scale to read fluid outlet pressure.

Key

- A** 0.7 MPa, 7 bar (100 psi) air pressure or 10.5 MPa, 105 bar (1500 psi) hydraulic oil pressure
 - B** 0.5 MPa, 4.9 bar (70 psi) air pressure or 7.5 MPa, 75 bar (1050 psi) hydraulic oil pressure
 - C** 0.3 MPa, 2.8 bar (40 psi) air pressure or 4.2 MPa, 42 bar (600 psi) hydraulic oil pressure
- Test Fluid:** No. 10 Weight Oil

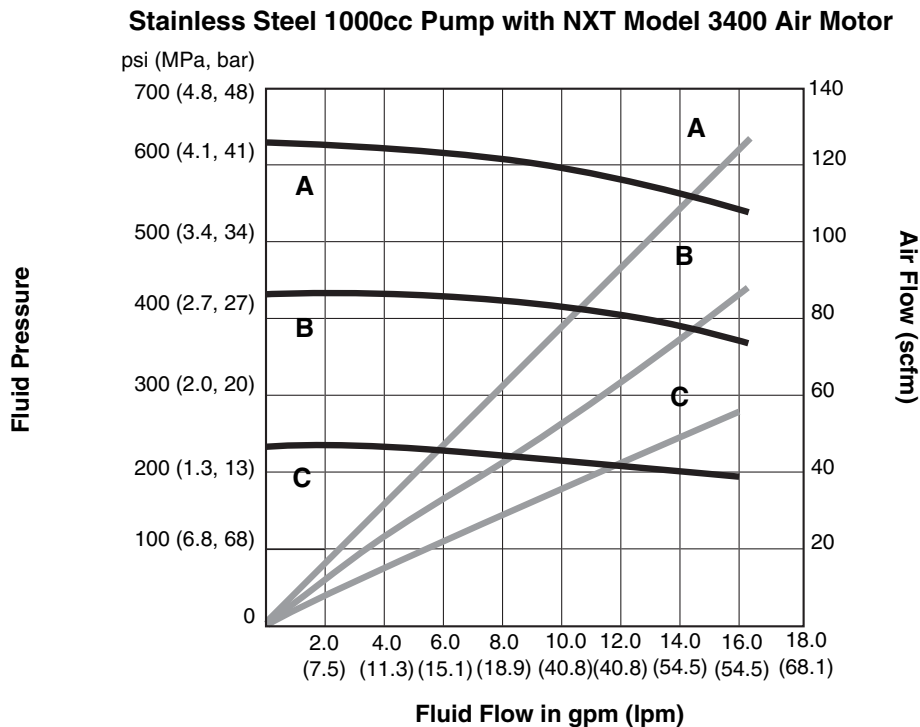

Key

- A** 0.7 MPa, 7 bar (100 psi) air pressure or 10.5 MPa, 105 bar (1500 psi) hydraulic oil pressure
 - B** 0.5 MPa, 4.9 bar (70 psi) air pressure or 7.5 MPa, 75 bar (1050 psi) hydraulic oil pressure
 - C** 0.3 MPa, 2.8 bar (40 psi) air pressure or 4.2 MPa, 42 bar (600 psi) hydraulic oil pressure
- Test Fluid:** No. 10 Weight Oil

Carbon Steel 1000cc Pump with NXT Model 3400 Air Motor

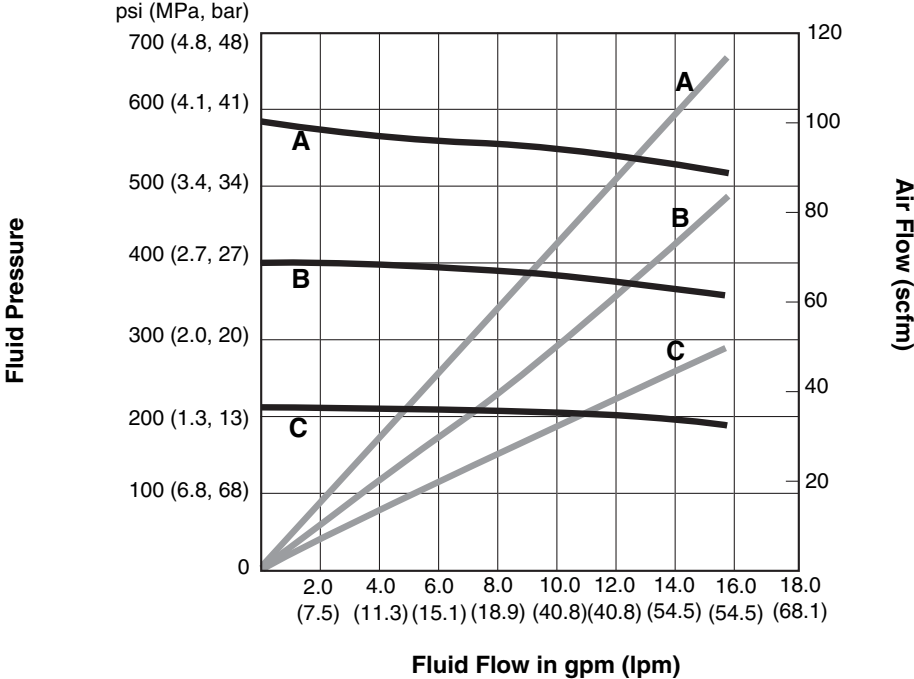

Carbon Steel 1000cc Pump with NXT Model 6500 Air Motor

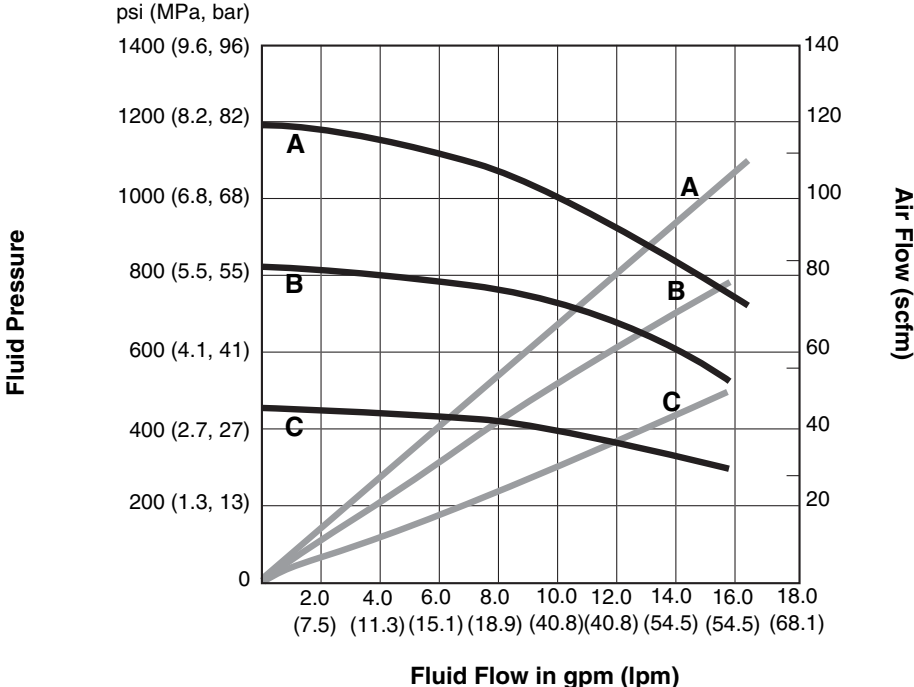

Graco Standard Warranty

Graco warrants all equipment referenced in this document which is manufactured by Graco and bearing its name to be free from defects in material and workmanship on the date of sale to the original purchaser for use. With the exception of any special, extended, or limited warranty published by Graco, Graco will, for a period of twelve months from the date of sale, repair or replace any part of the equipment determined by Graco to be defective. This warranty applies only when the equipment is installed, operated and maintained in accordance with Graco's written recommendations.

This warranty does not cover, and Graco shall not be liable for general wear and tear, or any malfunction, damage or wear caused by faulty installation, misapplication, abrasion, corrosion, inadequate or improper maintenance, negligence, accident, tampering, or substitution of non-Graco component parts. Nor shall Graco be liable for malfunction, damage or wear caused by the incompatibility of Graco equipment with structures, accessories, equipment or materials not supplied by Graco, or the improper design, manufacture, installation, operation or maintenance of structures, accessories, equipment or materials not supplied by Graco.

This warranty is conditioned upon the prepaid return of the equipment claimed to be defective to an authorized Graco distributor for verification of the claimed defect. If the claimed defect is verified, Graco will repair or replace free of charge any defective parts. The equipment will be returned to the original purchaser transportation prepaid. If inspection of the equipment does not disclose any defect in material or workmanship, repairs will be made at a reasonable charge, which charges may include the costs of parts, labor, and transportation.

THIS WARRANTY IS EXCLUSIVE, AND IS IN LIEU OF ANY OTHER WARRANTIES, EXPRESS OR IMPLIED, INCLUDING BUT NOT LIMITED TO WARRANTY OF MERCHANTABILITY OR WARRANTY OF FITNESS FOR A PARTICULAR PURPOSE.

Graco's sole obligation and buyer's sole remedy for any breach of warranty shall be as set forth above. The buyer agrees that no other remedy (including, but not limited to, incidental or consequential damages for lost profits, lost sales, injury to person or property, or any other incidental or consequential loss) shall be available. Any action for breach of warranty must be brought within two (2) years of the date of sale.

GRACO MAKES NO WARRANTY, AND DISCLAIMS ALL IMPLIED WARRANTIES OF MERCHANTABILITY AND FITNESS FOR A PARTICULAR PURPOSE, IN CONNECTION WITH ACCESSORIES, EQUIPMENT, MATERIALS OR COMPONENTS SOLD BUT NOT MANUFACTURED BY GRACO. These items sold, but not manufactured by Graco (such as electric motors, switches, hose, etc.), are subject to the warranty, if any, of their manufacturer. Graco will provide purchaser with reasonable assistance in making any claim for breach of these warranties.

In no event will Graco be liable for indirect, incidental, special or consequential damages resulting from Graco supplying equipment hereunder, or the furnishing, performance, or use of any products or other goods sold hereto, whether due to a breach of contract, breach of warranty, the negligence of Graco, or otherwise.

FOR GRACO CANADA CUSTOMERS

The Parties acknowledge that they have required that the present document, as well as all documents, notices and legal proceedings entered into, given or instituted pursuant hereto or relating directly or indirectly hereto, be drawn up in English. Les parties reconnaissent avoir convenu que la rédaction du présente document sera en Anglais, ainsi que tous documents, avis et procédures judiciaires exécutés, donnés ou intentés, à la suite de ou en rapport, directement ou indirectement, avec les procédures concernées.

Graco Information

For the latest information about Graco products, visit www.graco.com.

For patent information, see www.graco.com/patents.

TO PLACE AN ORDER, contact your Graco distributor or call to identify the nearest distributor.

Phone: 612-623-6921 **or Toll Free:** 1-800-328-0211 **Fax:** 612-378-3505

*All written and visual data contained in this document reflects the latest product information available at the time of publication.
Graco reserves the right to make changes at any time without notice.*

Original instructions. This manual contains English. MM 311833

Graco Headquarters: Minneapolis

International Offices: Belgium, China, Japan, Korea

GRACO INC. AND SUBSIDIARIES • P.O. BOX 1441 • MINNEAPOLIS MN 55440-1441 • USA

Copyright 2006, Graco Inc. All Graco manufacturing locations are registered to ISO 9001.

www.graco.com

Revision G, January 2021