

## LineLazer™ V 3900, 5900, 200HS, 200DC, 200MMA, ES2000 HP Auto Series and LineLazer™ V 250SPS and 250DC Airless Line Stripers

3A3428B

EN

***For the application of line striping materials.***

***For professional use only.***

***For outdoor use only.***

***Not for use in explosive atmospheres or hazardous locations.***

*Maximum Operating Pressure: 3300 psi (22.8 MPa, 228 bar)*



### **Important Safety Instructions**

Read all warnings and instructions in this manual and in related manuals.  
Be familiar with the controls and the proper usage of the equipment.  
Save these instructions.

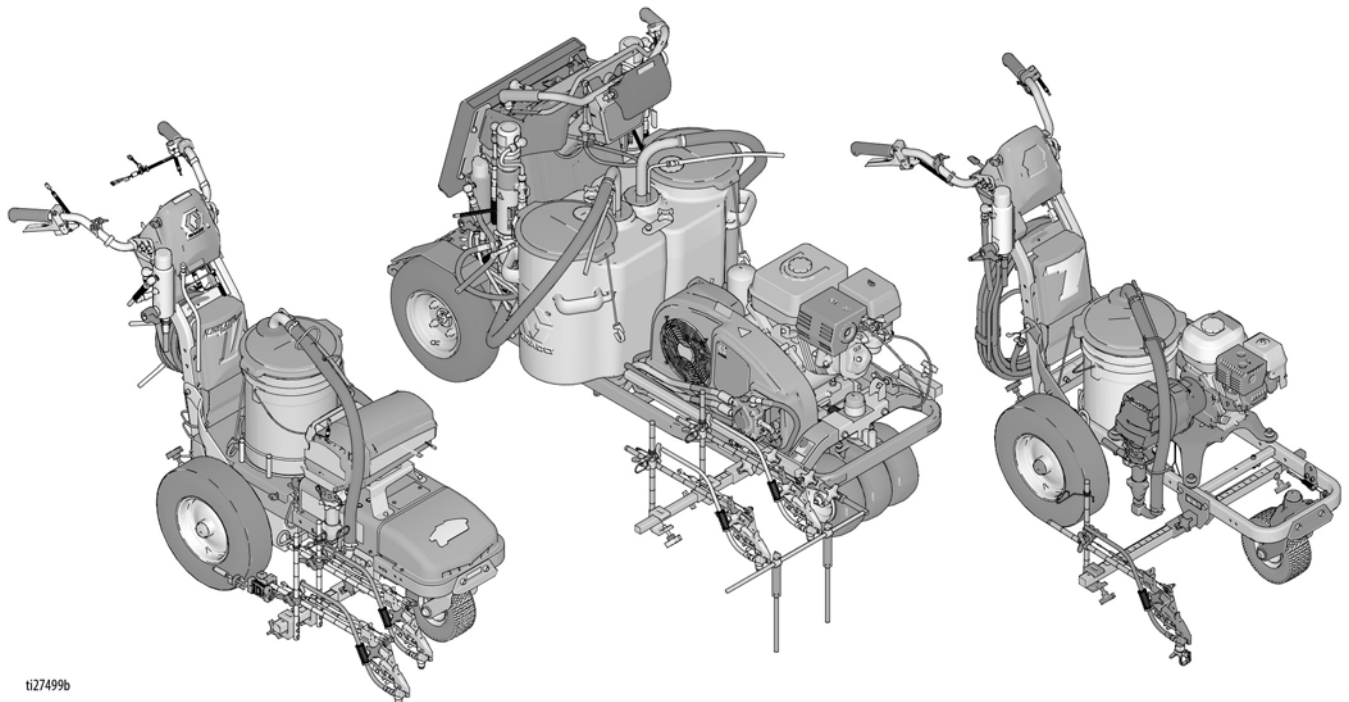

ti27499b

# Table of Contents

LineLazer V Auto-Layout System .....	3
LineLazer V 250SPS & 250DC .....	3
Calibration .....	4
Measure Mode .....	5
Basic Stall Layout: Layout Mode .....	6
Basic Stall Layout: Stall Calculator .....	7
Basic Stall Layout: Layout Mode .....	8
Basic Stall Layout: Stall Calculator .....	9
Basic Stall Layout: Layout Mode .....	10
Basic Stall Layout: Striping Mode .....	11
Island Stall Layout: Layout Mode .....	12
Island Stall Layout: Layout Mode .....	13
Island Stall Layout: Striping Mode .....	14
Radius Stall Layout: Layout Mode .....	15
Radius Stall Layout: Stall Calculator .....	16
Radius Stall Layout: Layout Mode .....	17
Radius Stall Layout: Stall Calculator .....	18
Radius Stall Layout: Layout Mode .....	19
Radius Stalls .....	20
Angle Stall Layout: Parking Mode .....	21
Angle Stall Layout: Angle Calculation .....	22
Angle Stall Layout: Layout Mode .....	23
Angle Stall Layout: Striping Mode .....	24
Cross Hatch Layout: Layout Mode .....	25
Cross Hatch Layout: Striping Mode .....	26
Cross Hatch Layout: Striping Mode .....	27
Marker Mode Layout: Center Lines and Lane Lines Mode .....	28
Graco Standard Warranty .....	30

**NOTE:** For Best results, always dot in the same direction.

**NOTE:** Minimum RPM for placing dots is 2600.

**NOTE:** Minimum pressure on LLIV 250SPS is 1000 psi.

# LineLazer V Auto-Layout System

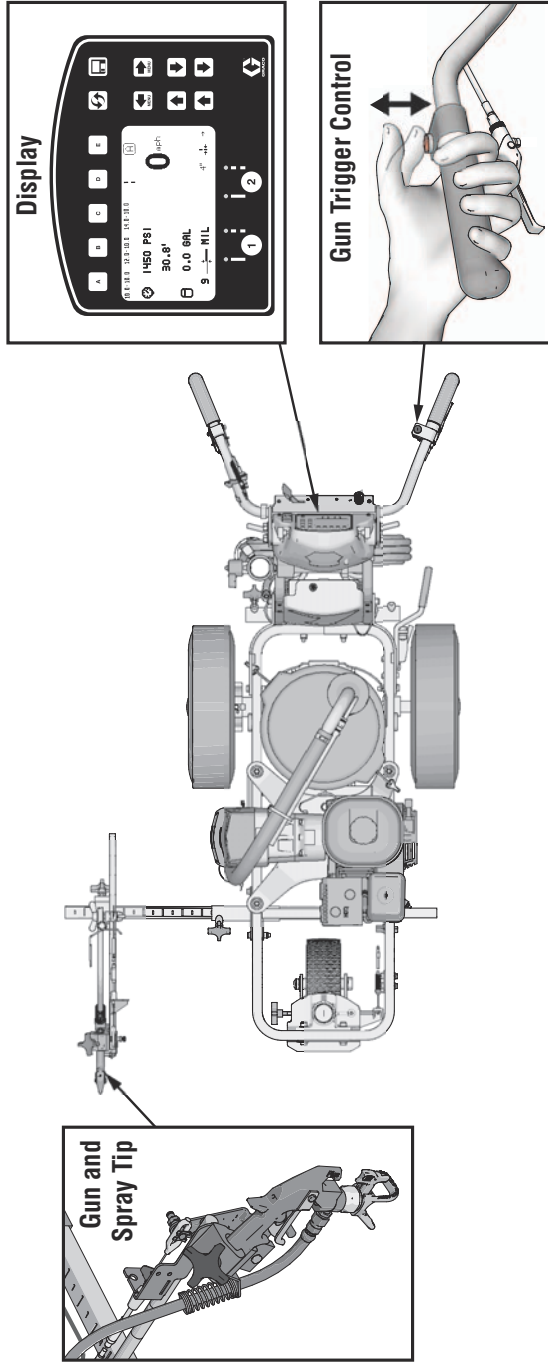

t28336a

# LineLazer V 250SPS & 250DC

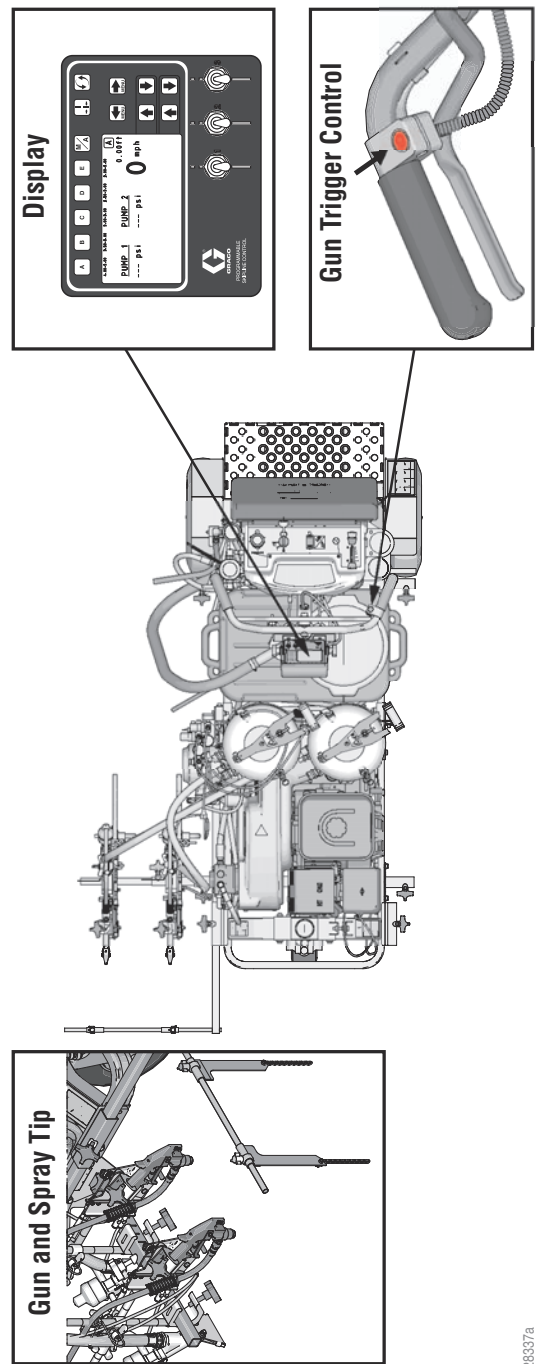

t28337a

# Calibration

## Minimum 25 ft precision course

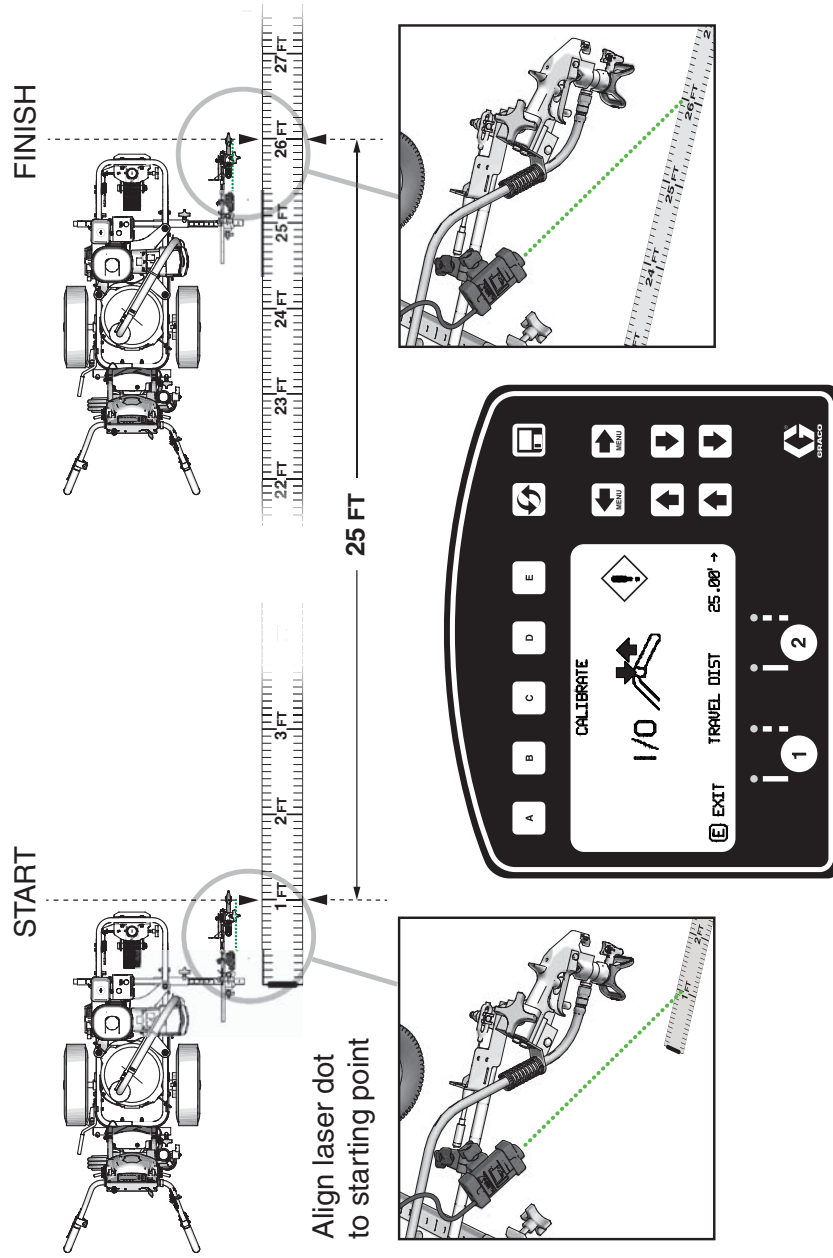

11263338a

### CALIBRATION AND UNITS

Press **REMOTE SWITCH** to **START** calibration. Press **REMOTE SWITCH** to **FINISH** calibration.

**IMPORTANT NOTE:** For best results, calibrate to a minimum of 25 ft. Use only steel measuring tape. Precise start and stop are necessary. Calibration distance above 100 ft is not recommended due to inaccuracy with setting up the course. Tire air pressure variations can negatively impact accuracy of unit.

**CHANGE UNITS** changes all displayed values to metric or standard units of measure.



# Measure Mode

Used for measuring and marking specific distances

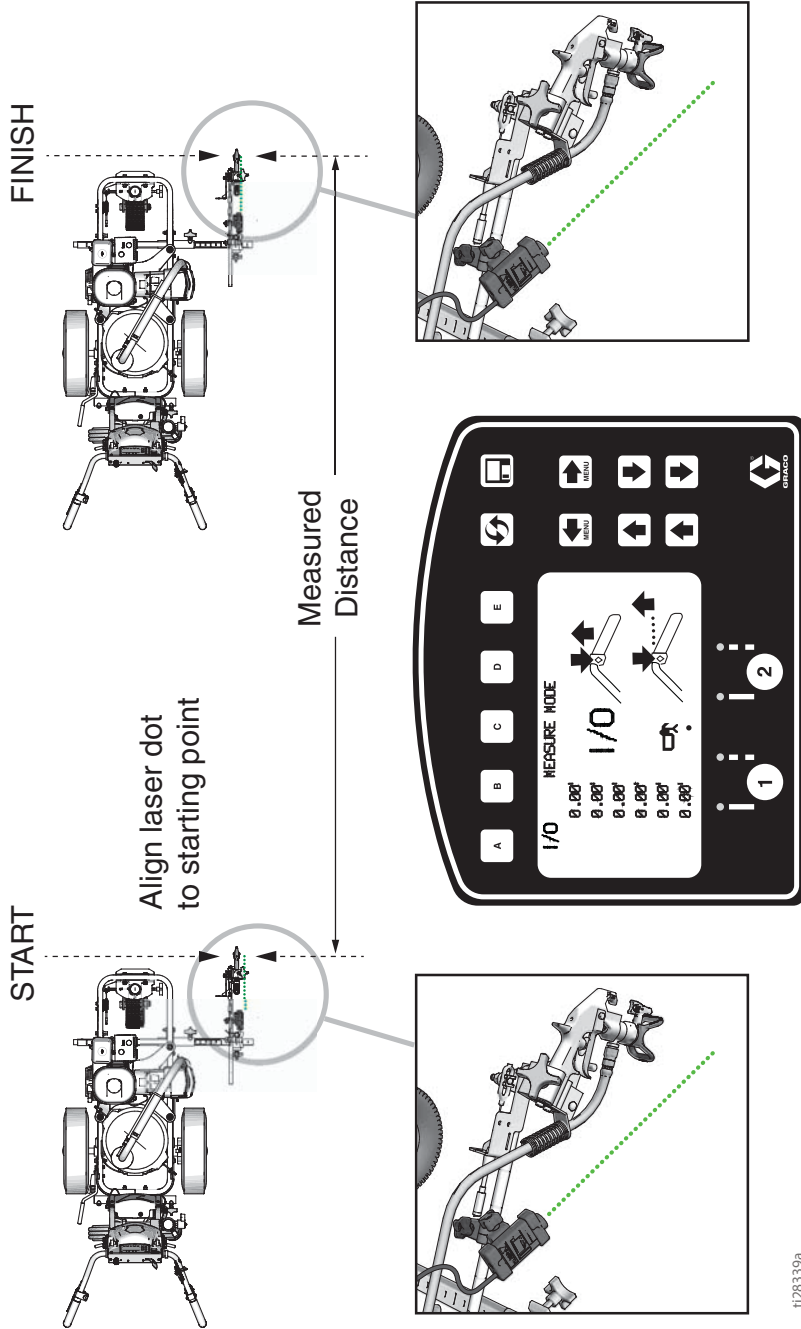

## MEASURE MODE

At any time while in **MEASURE MODE**, if an Auto gun is set to active, momentarily hold down **GUN TRIGGER CONTROL** to apply a dot. Holding down **GUN TRIGGER CONTROL** will produce continuous dotted line with 1 foot dot spacing when moving, used for pre-marking.

Press **GUN TRIGGER CONTROL** to **START**. Press **GUN TRIGGER CONTROL** to **FINISH**. Measurements automatically increment down on screen, last measurements display at all times.

**NOTE:** The striper measures moving forward or reverse.

# Basic Stall Layout: Layout Mode

Establishing outer boundary with reference dots

**NOTE:** For best results, always dot in the same direction.

**NOTE:** Minimum RPM for placing dots is 2600.

**NOTE:** Minimum pressure on LLV 250SPS & 250DC is 1000 psi.

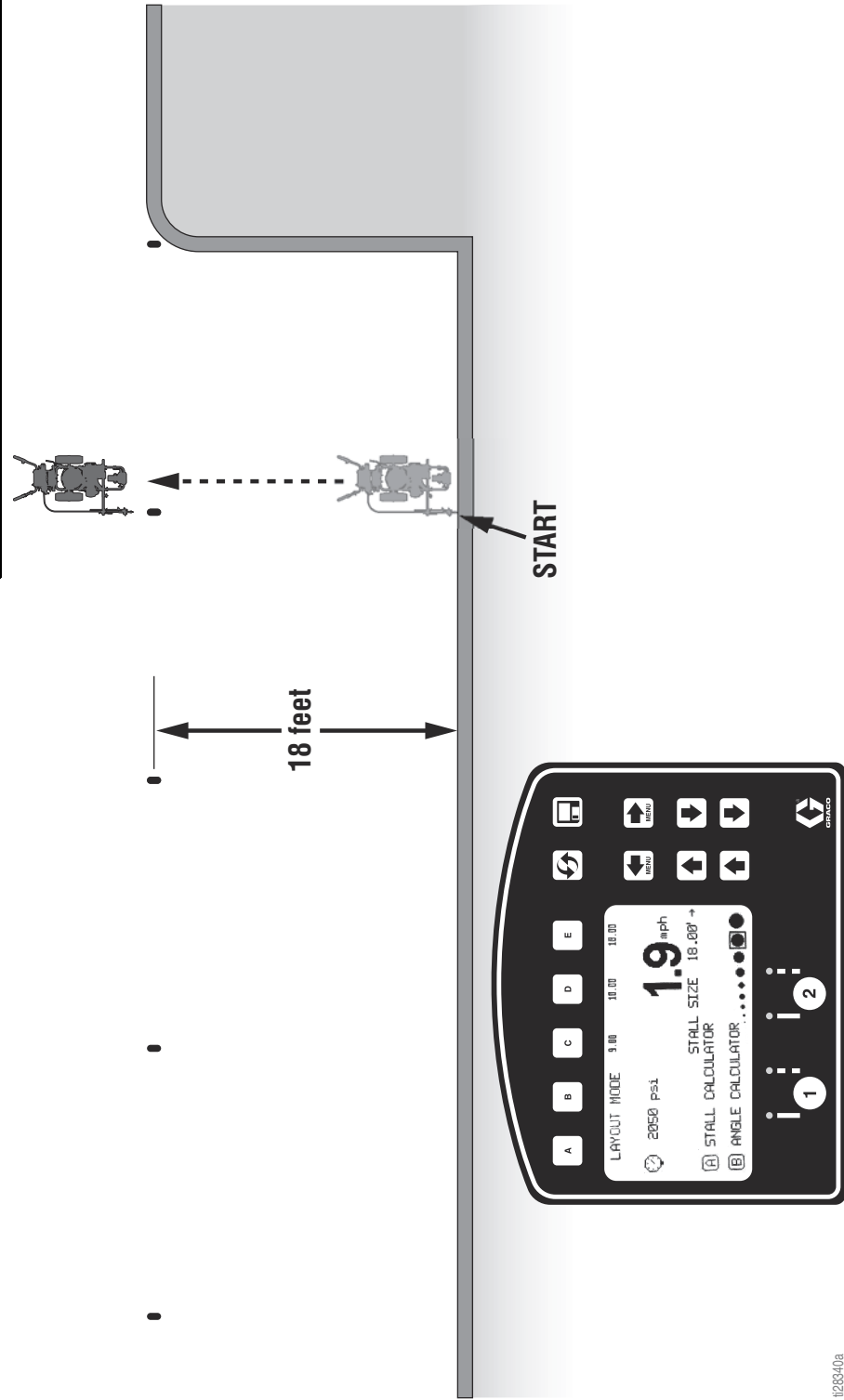

## LAYOUT

### MODE

Set 1 or 2 guns to active. Press **GUN TRIGGER CONTROL** to **START** and **FINISH**.

Establish enough reference dots to guide striper for applying stall lines. In this case, 18 ft from inner curbing.

1228340a

# Basic Stall Layout: Stall Calculator

Measure for automatic calculation or select desired stall size

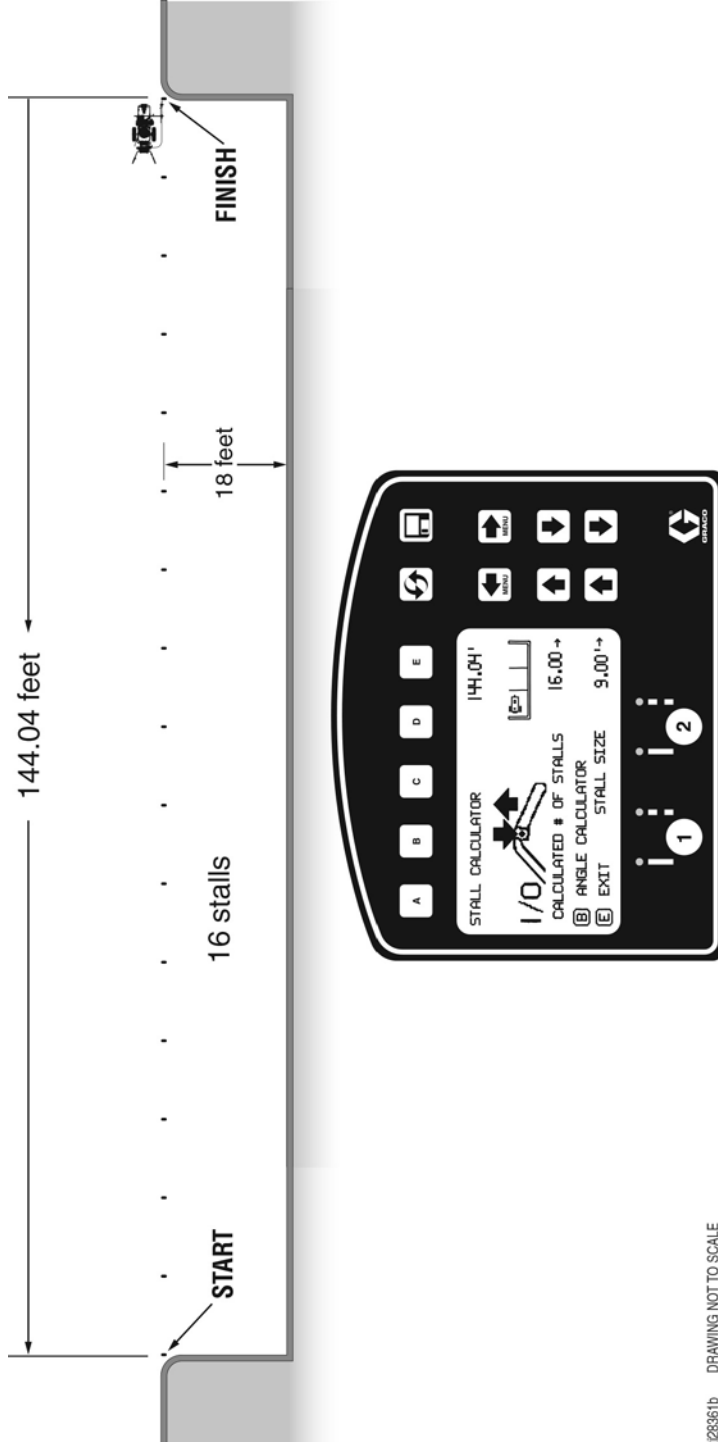

28361b DRAWING NOT TO SCALE

## STALL CALCULATOR

Press **GUN TRIGGER CONTROL** to **START** and **FINISH** calculation. **IMPORTANT NOTE:** Start-point and finish-point accuracy is critical.

Press **GUN TRIGGER CONTROL** to start measuring. Follow the established 18 ft reference dots, measure from start to finish. Press remote switch to stop measuring.

Use up/down arrows to adjust number of stalls as desired.

**NOTE:** System automatically transfers the calculated **STALL SIZE** from **STALL CALCULATOR** to **LAYOUT MODE** screen.

# Basic Stall Layout: Layout Mode

Mark dots at beginning of each stall

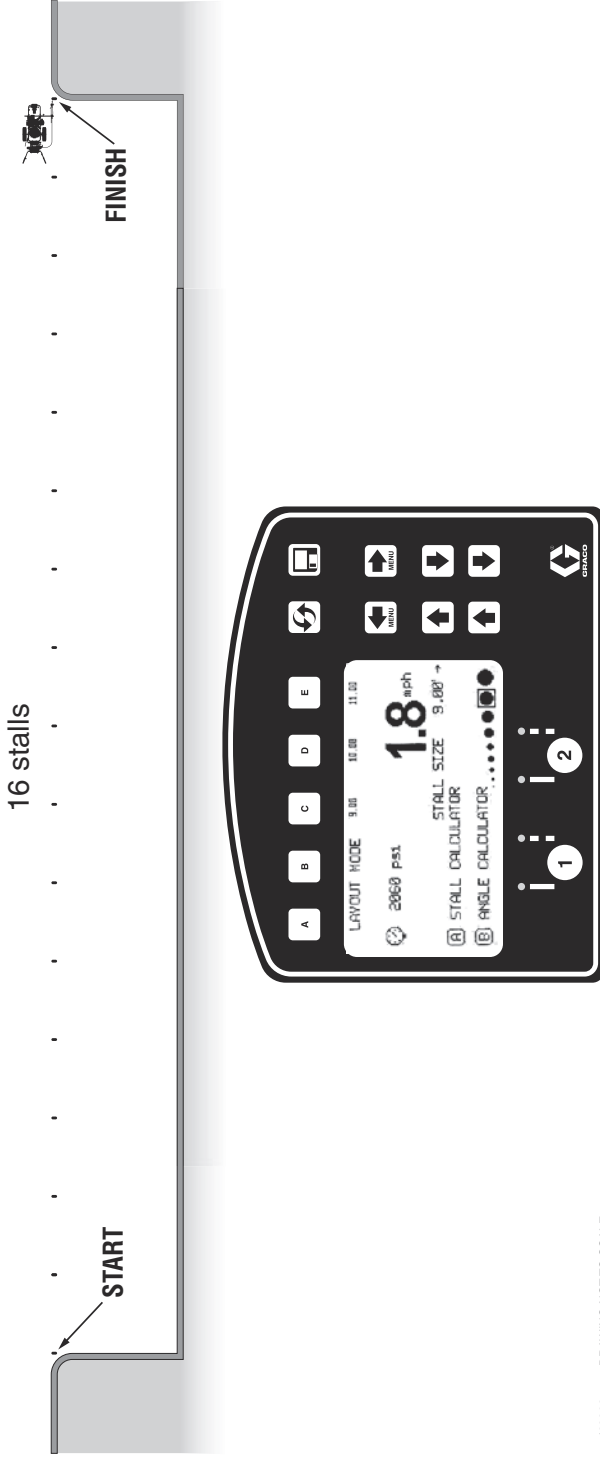

1128362a DRAWING NOT TO SCALE

**LAYOUT MODE**  
 Press **GUN TRIGGER CONTROL** to **START** and **FINISH** dots.

Utilizing calculated stall size, apply dots, traveling from start to finish.

**NOTE:** System automatically transfers the calculated **STALL SIZE** from **STALL CALC** screen if desired.

# Basic Stall Layout: Stall Calculator

Measuring between curbs for automatic calculation

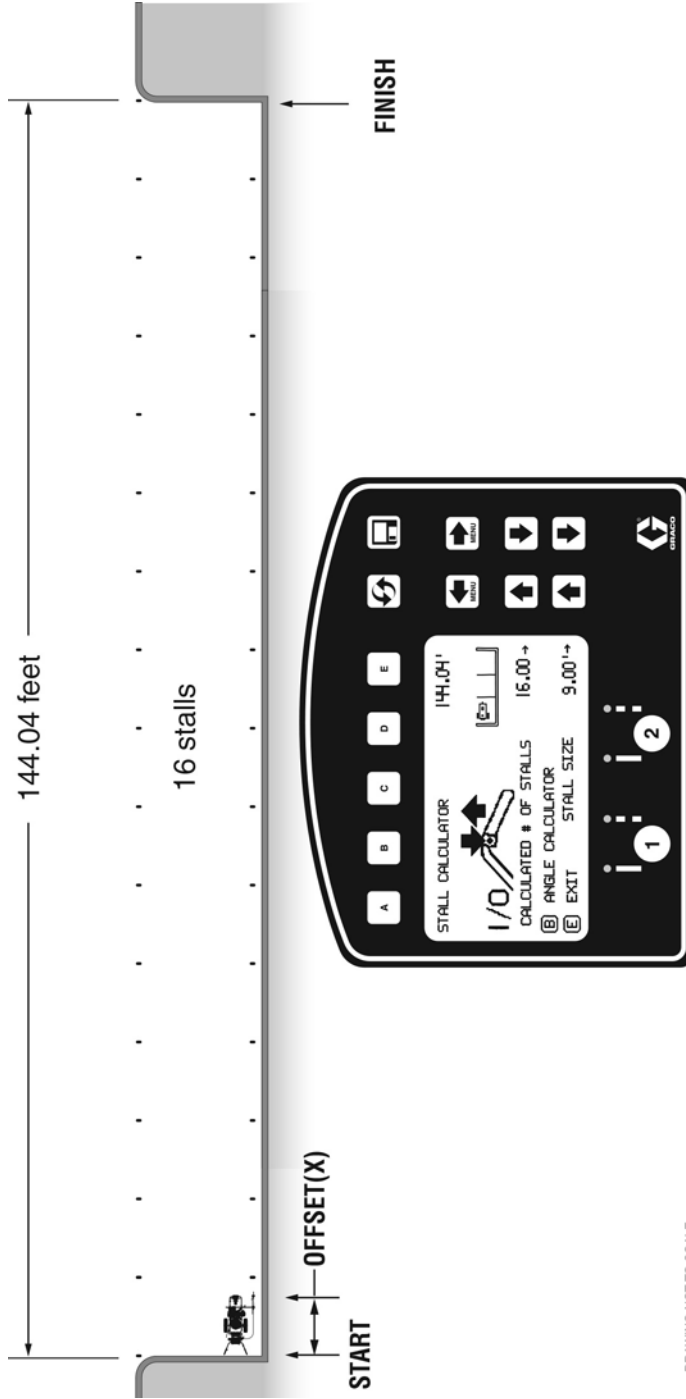

## STALL CALCULATOR OFFSET

Back the striper up to the curb, then use a tape measure to measure from where the tire touches the curb to the laser dot on the ground.

Use to enter the offset (x) value.

This value can be stored by holding for 2 seconds.

The value stored under can be added to the measured distance before or after the measurement is taken between curbs.

The offset (x) value can also be adjusted before or after the measurement is taken by using .

Stall size and calculated number of stalls are both adjustable.

Press **GUN TRIGGER CONTROL** to START and FINISH calculation

**IMPORTANT NOTE:** Start-point and finish-point accuracy is critical.

Press gun trigger control at start measuring following curbing as a reference. Press remote switch to stop measuring.

Use up/down arrows to adjust number of stalls as desired.

**NOTE:** System automatically transfers the calculated **STALL SIZE** from **STALL CALCULATOR** to **LAYOUT MODE** screen.

# Basic Stall Layout: Layout Mode

Mark dots at end of each stall

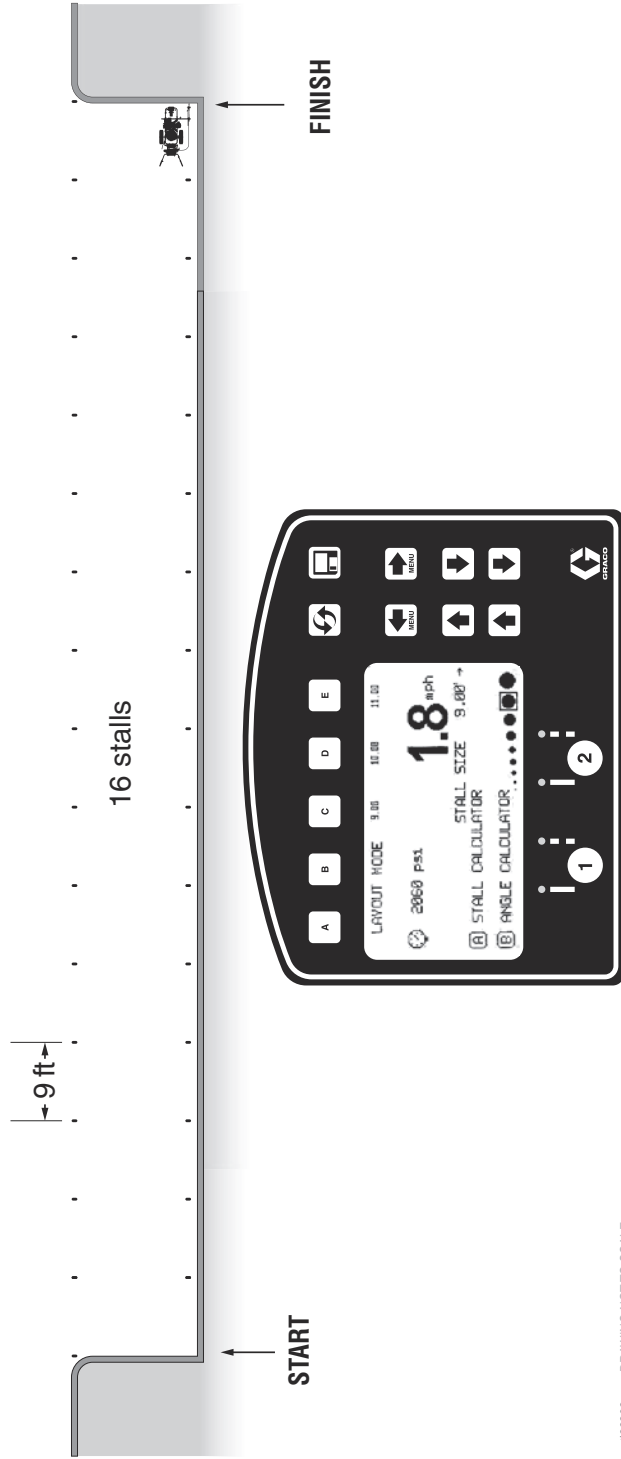

112863a DRAWING NOT TO SCALE

**LAYOUT MODE**  
Press **GUN TRIGGER CONTROL** to **START** and **FINISH** dots.

Press remote switch at start while following curbing as a reference applying evenly spaced dots. Press remote switch at finish to stop dots.

Establish first stall perpendicular to curb as shown (if curbing does not allow room for striper).

# Basic Stall Layout: Striping Mode

Paint lines (connect the dots)

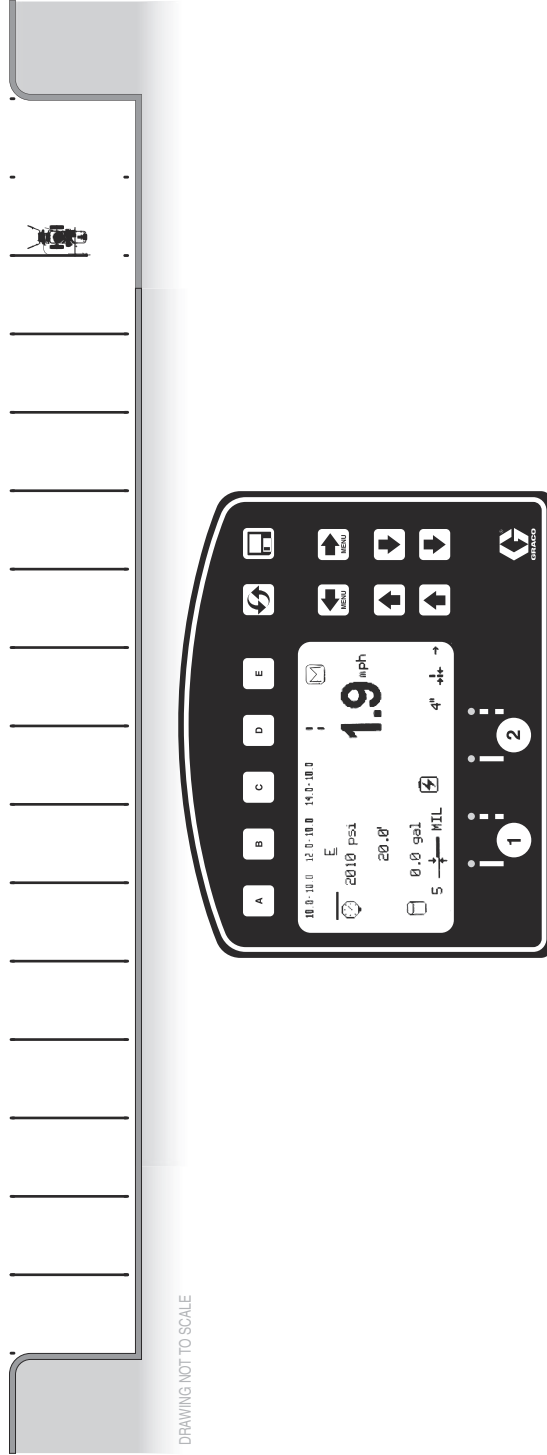

123364a

**STRIPING MODE**  
Simply connect the dots with your sprayer.



# Island Stall Layout: Layout Mode

Establish the center line and outer boundary first

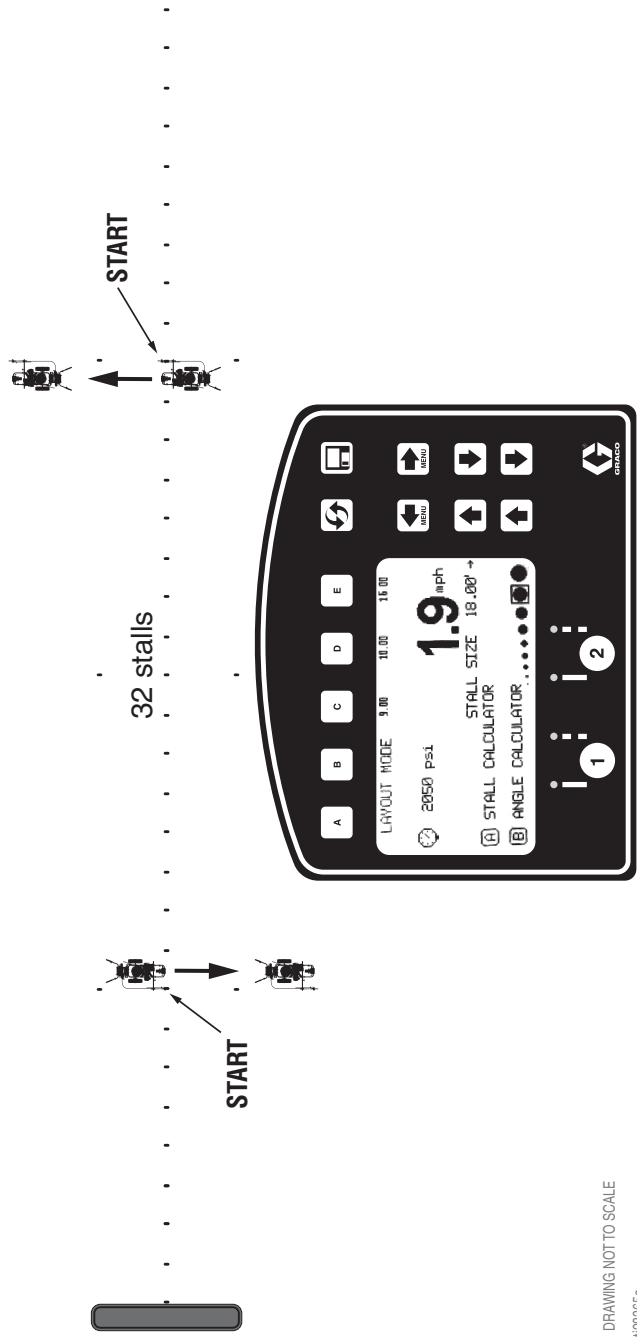

DRAWING NOT TO SCALE  
1128365a

## LAYOUT MODE

Set a gun to active. Press **GUN TRIGGER CONTROL** to start and stop dots.

Establish enough reference dots to guide striper for applying stall lines by using **LAYOUT MODE** measuring 18 ft out from centerline.

**NOTE:** The striper measures moving forward or reverse, as shown, placing evenly spaced dots at desired spacing.

# Island Stall Layout: Layout Mode

Place dots at the beginning of each stall line

- NOTE: For Best results, always dot in the same direction.
- NOTE: Minimum RPM for placing dots is 2600.
- NOTE: Minimum pressure on LLV 250SPS & 250DC is 1000 psi.

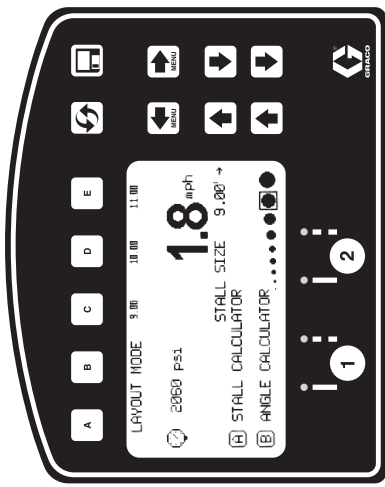

DRAWING NOT TO SCALE  
1428357a

**LAYOUT MODE**  
Set gun to active. Press **GUN TRIGGER CONTROL** to start and stop dots.  
**NOTE:** See Basic Stalls section (pages 4-8) to automatically measure and calculate stall size.

# Island Stall Layout: Striping Mode

Paint lines (connect the dots)

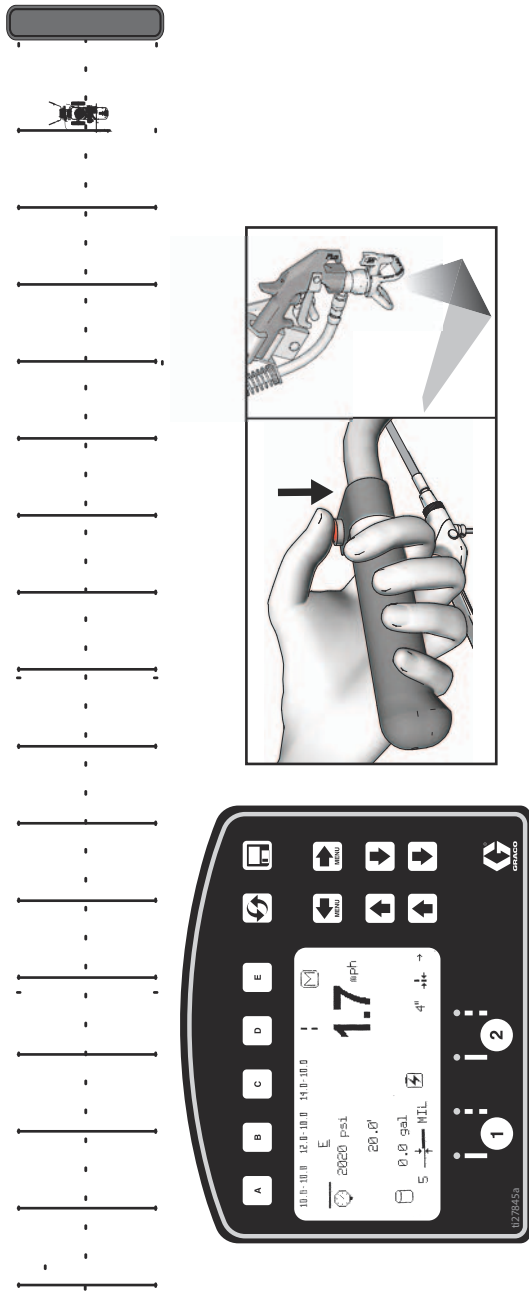

112B368a

DRAWING NOT TO SCALE

**STRIPING MODE**  
Simply connect the dots with the striper.

# Radius Stall Layout: Layout Mode

Place evenly spaced dots at beginning of each stall

**NOTE:** For best results, always dot in the same direction.

**NOTE:** Minimum RPM for placing dots is 2600.

**NOTE:** Minimum pressure on LLV 250SPS & 250DC is 1000 psi.

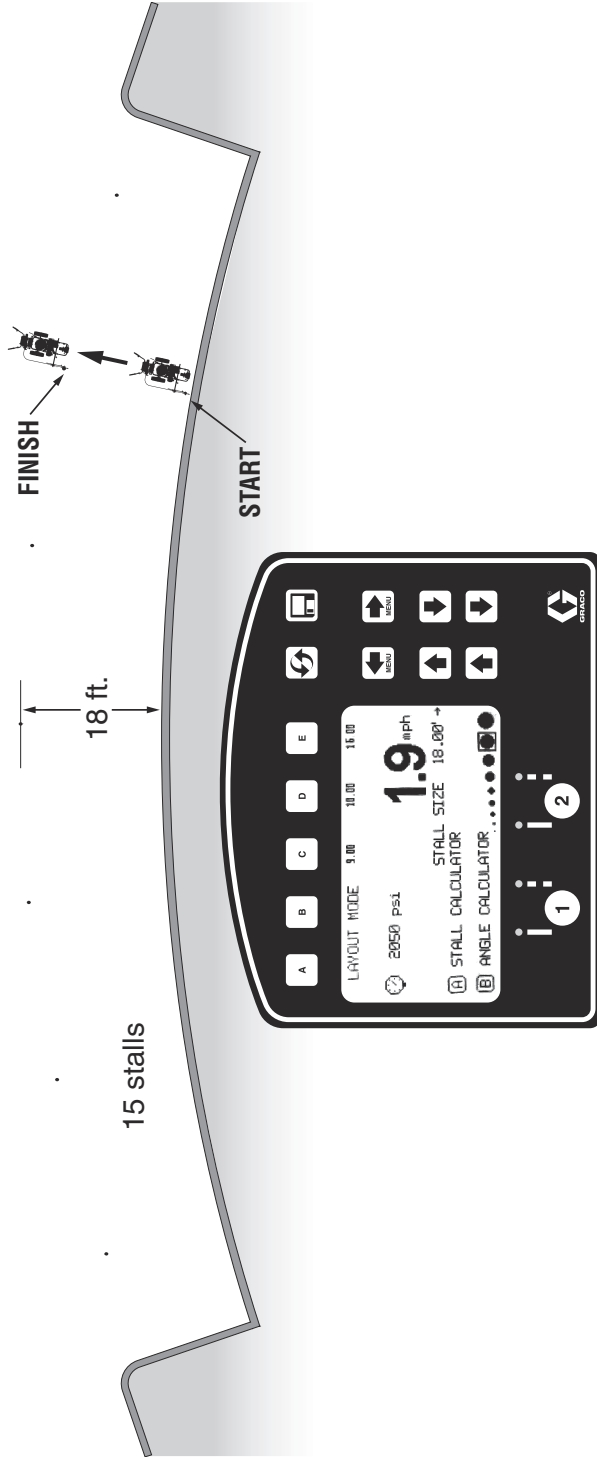

1126369a DRAWING NOT TO SCALE

## LAYOUT MODE

Set gun to active. Press **GUN TRIGGER CONTROL** to **START** and **FINISH**.

Establish enough reference dots to guide striper for measuring and applying stall lines. In this case, 18 feet from inner curbing.

# Radius Stall Layout: Stall Calculator

Measure inner perimeter distance

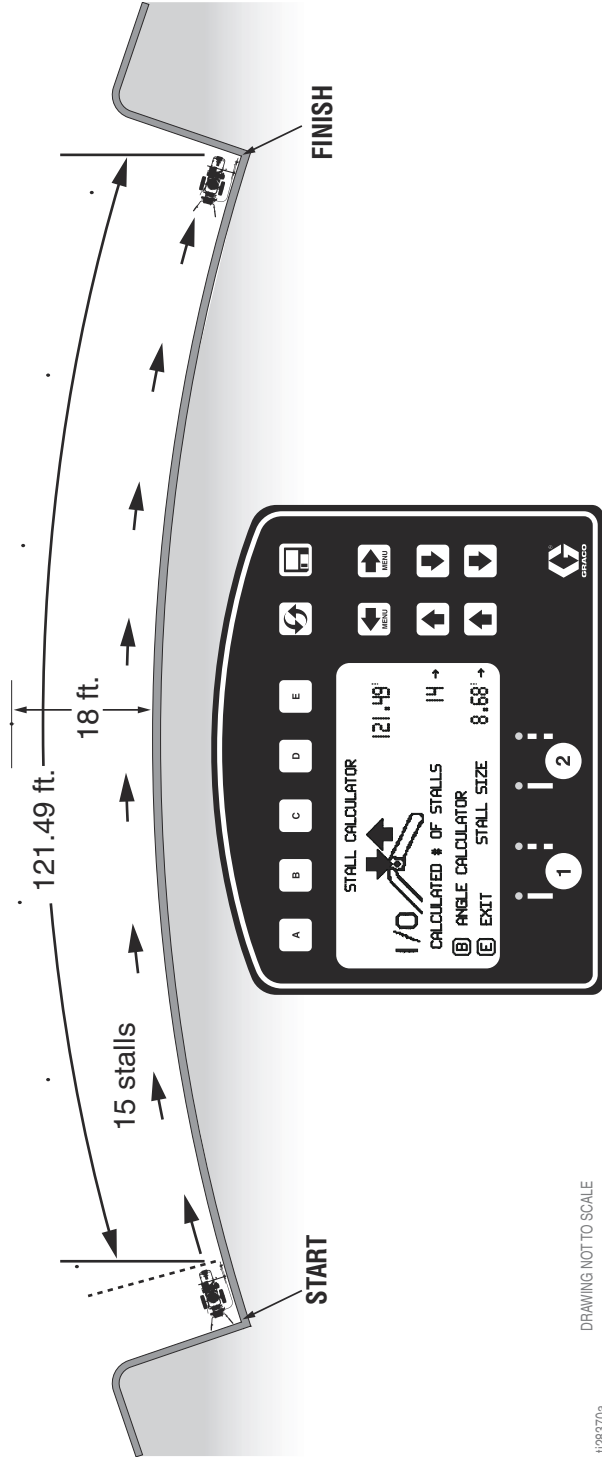

DRAWING NOT TO SCALE

1128370a

## LAYOUT MODE

Press **GUN TRIGGER CONTROL** to START and FINISH measuring.  
**NOTE:** Measure start-point and finish-point accuracy is critical.

Press remote switch at start, follow the curbing as a reference to guide striper along path measuring from start to finish. Press **GUN TRIGGER CONTROL** at finish to stop measuring.

Use up/down arrows to adjust correct number of stalls. New parking stall size will display under **STALL SIZE**. Establish first stall if curbing does not allow room for striper (in this case 15 less 1 = 14 for the calculation).

**NOTE:** System automatically transfers the calculated **STALL SIZE** from **STALL CALC** to **LAYOUT MODE** screen.

# Radius Stall Layout: Layout Mode

Mark dots at end of each stall

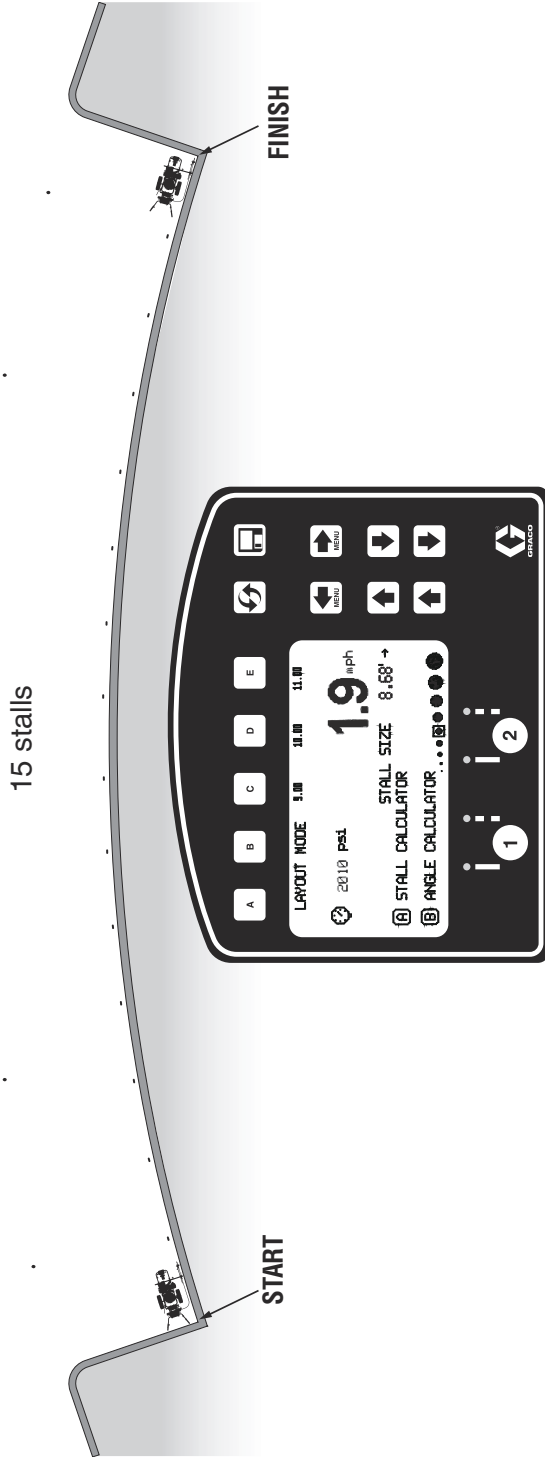

1128371a DRAWING NOT TO SCALE

## LAYOUT MODE

Press **REMOTE SWITCH** to **START** and **FINISH** dots.

Utilizing calculated stall size, apply dots, traveling from start to finish.

Establish first stall perpendicular to curb as shown (if curbing does not allow room for striping).

**NOTE:** System automatically transfers the calculated **STALL SIZE** from **STALL CALC** to **LAYOUT MODE** screen.

# Radius Stall Layout: Stall Calculator

Measure outer perimeter distance

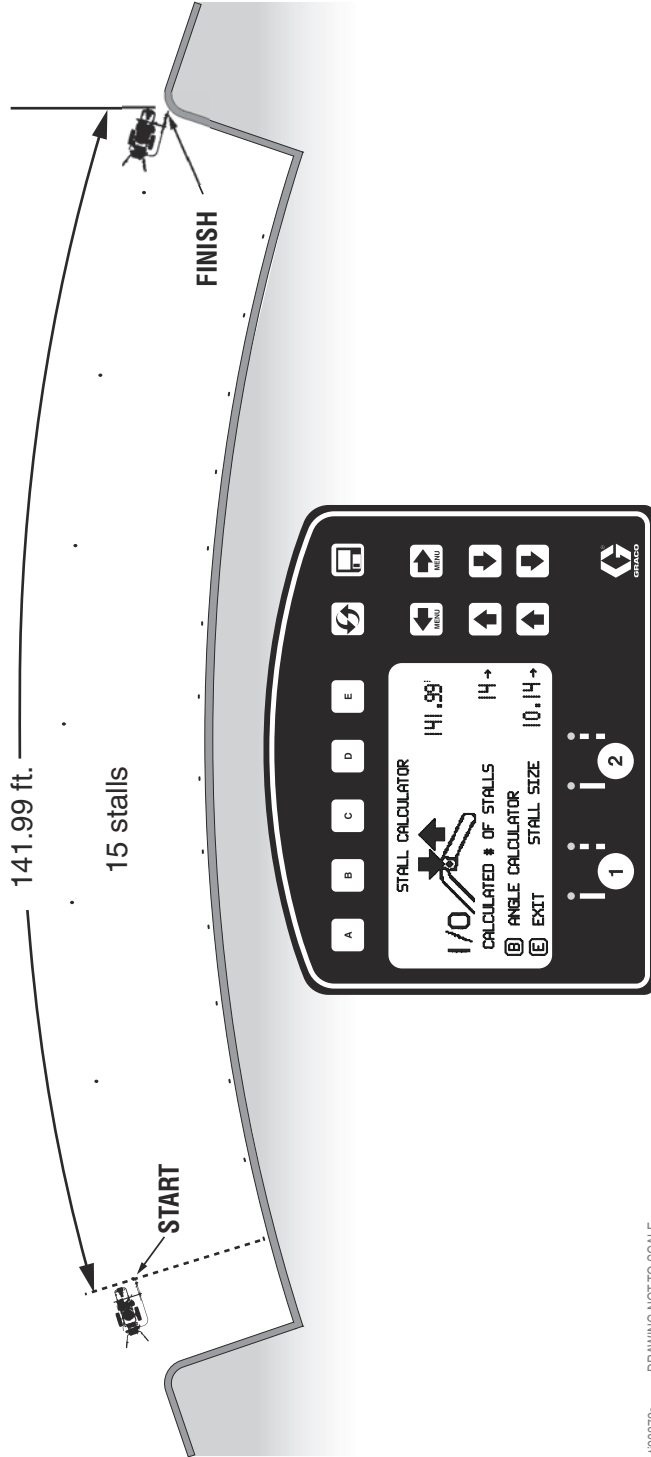

128372a DRAWING NOT TO SCALE

## STALL CALC

Set gun to active. Press **GUN TRIGGER CONTROL** to **START** and **FINISH** measuring.

**NOTE:** Start-point and finish-point accuracy is crucial.

Press remote switch at start to begin measuring. Follow the established 18 ft reference dots measuring from start to finish. Press remote switch again to stop measuring.

Use up/down arrows to adjust correct number of stalls.

**NOTE:** System automatically transfers the calculated **STALL SIZE** from **STALL CALC** to **LAYOUT MODE** screen.



# Radius Stall Layout: Layout Mode

Place evenly spaced dots at beginning of each stall

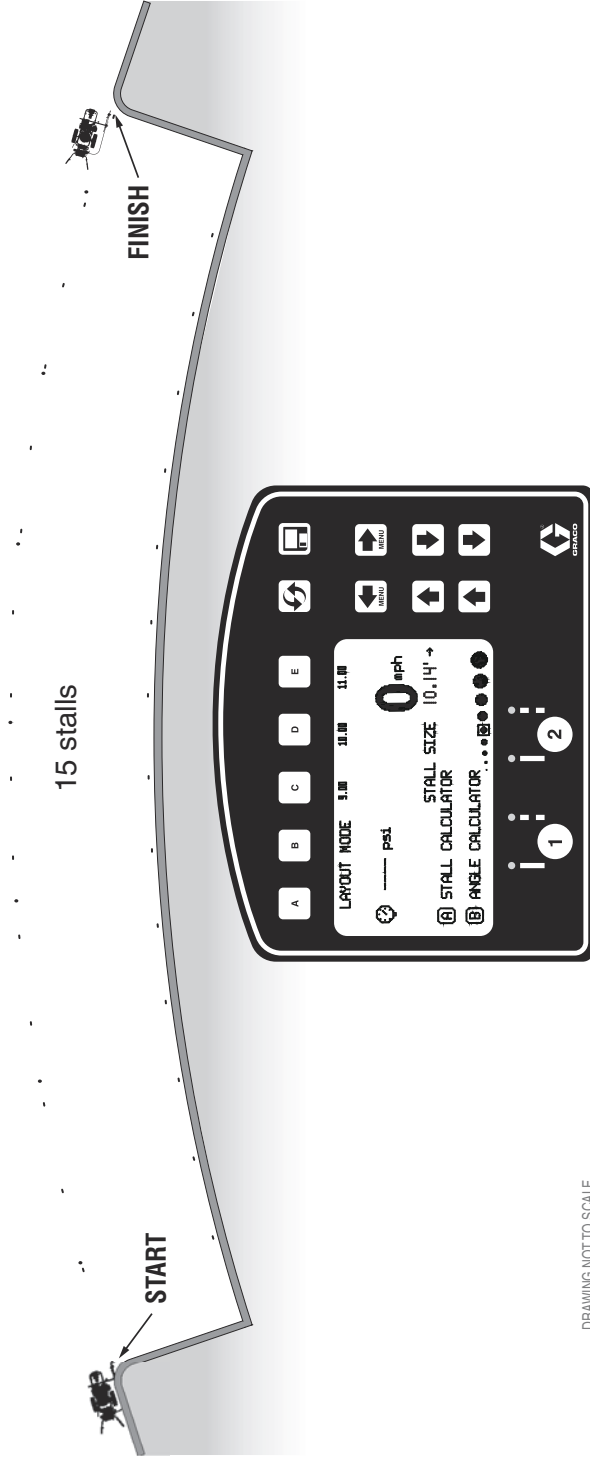

128873a

DRAWING NOT TO SCALE

## LAYOUT MODE

Set gun to active. Press **GUN TRIGGER CONTROL** to **START** and **FINISH** dots.

Utilizing calculated stall size, apply dots traveling from start to finish.

**NOTE:** System automatically transfers the calculated **STALL SIZE** from **STALL CALC** to **LAYOUT MODE** screen.

# Radius Stalls Paint Lines

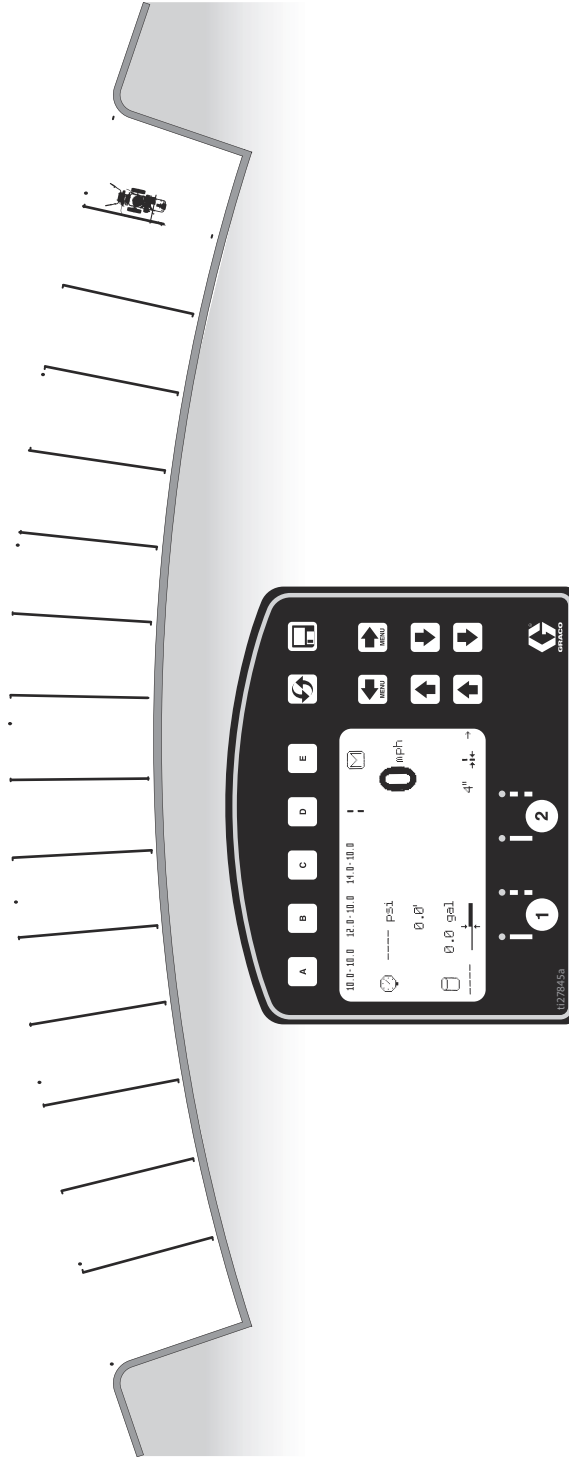

DRAWING NOT TO SCALE

1128374a

**STRIPING MODE**  
Simply connect the dots with the striper.

# Angle Stall Layout: Parking Mode

Establish the center line and outer boundary

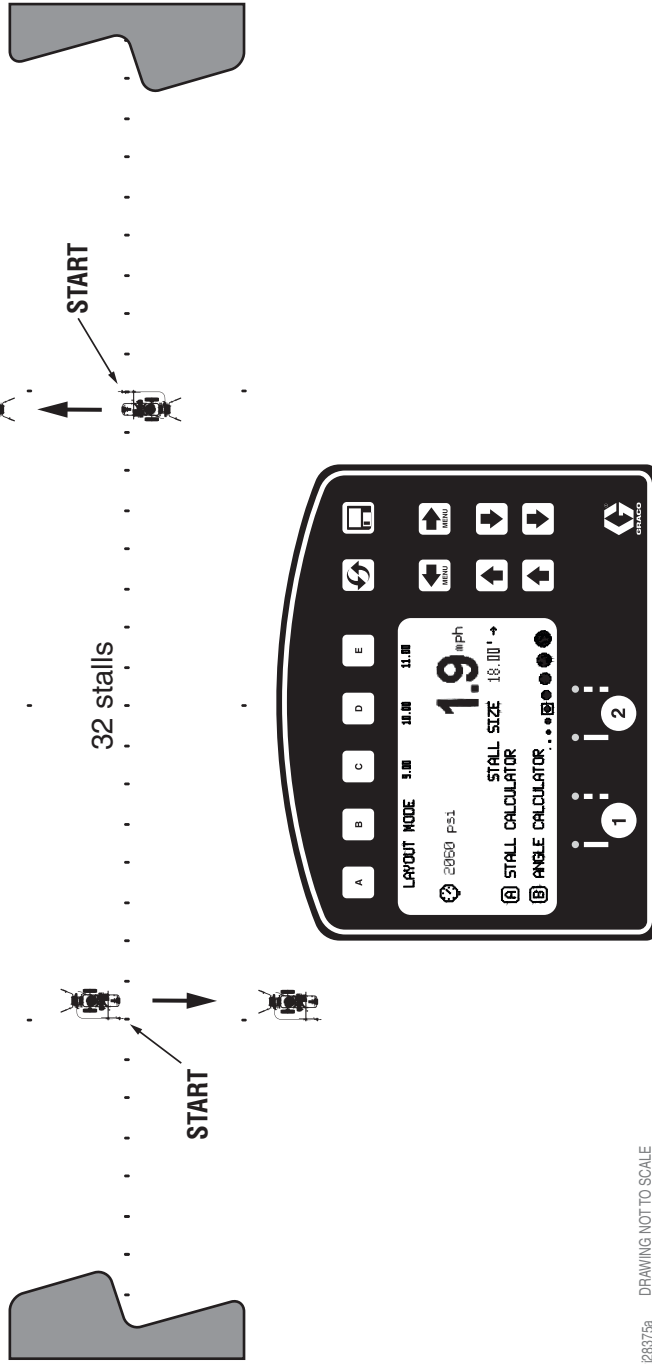

125375a DRAWING NOT TO SCALE

**NOTE:** For best results, always dot in the same direction.  
**NOTE:** Minimum RPM for placing dots is 2600.  
**NOTE:** Minimum pressure on LLV 250SPS & 250DC is 1000 psi.

**LAYOUT MODE**  
 Set gun to active. Press **GUN TRIGGER CONTROL** to **START** and **FINISH** dots.  
 Establish enough reference dots to guide striper for applying stall lines by using **LAYOUT MODE** measuring 18 ft out from centerline.  
**NOTE:** The striper measures moving forward or reverse, as shown, placing evenly-spaced dots at desired spacing.

# Angle Stall Layout: Angle Calculation

Measure outer boundary

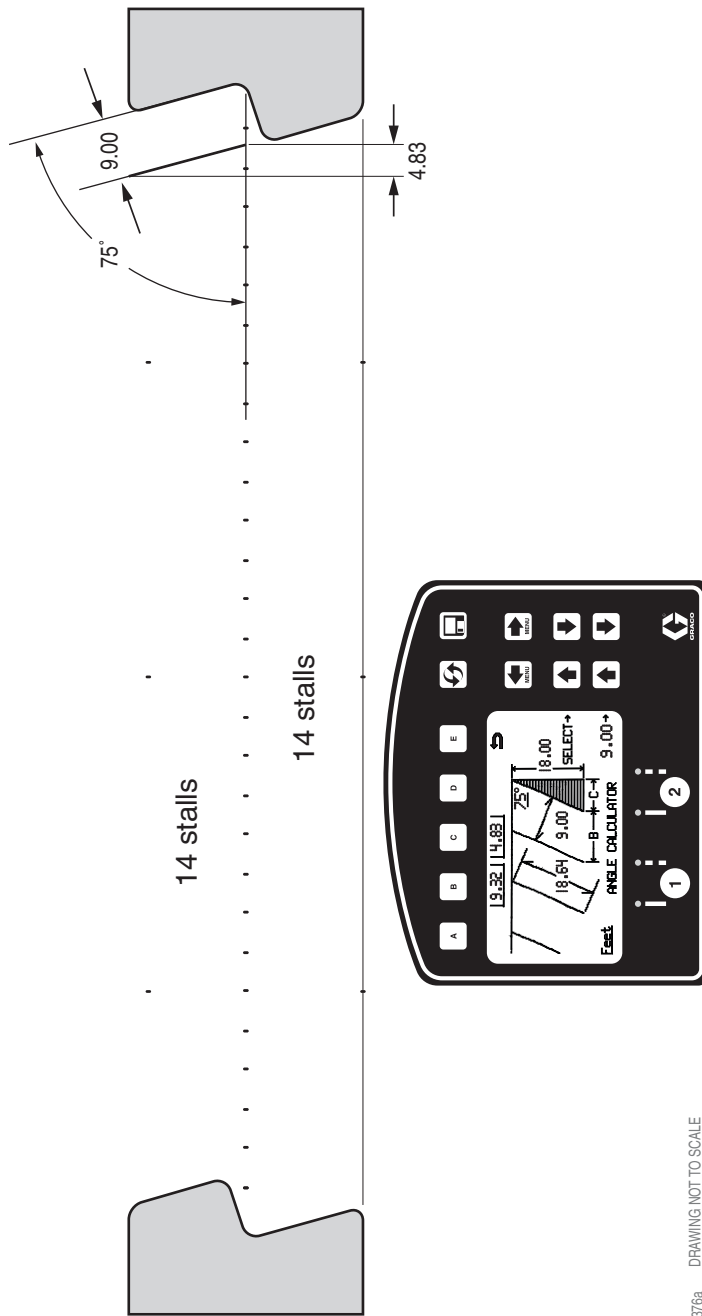

128376a DRAWING NOT TO SCALE

## ANGLE CALC

Use **KEY PAD** to adjust desired angle. Use up/down arrows to set desired **STALL DEPTH** and **STALL SIZE**. System automatically calculates “offset” and “dot spacing”.

Press **[B]** to transfer “dot spacing” distance to **LAYOUT MODE**. Press **[C]** to transfer “offset distance” to **LAYOUT MODE**.

**NOTE:** System does not transfer any number from **ANGLE CALC** to **LAYOUT MODE** screen if **[E]** is pressed.

# Angle Stall Layout: Layout Mode

Mark dots at end of each stall

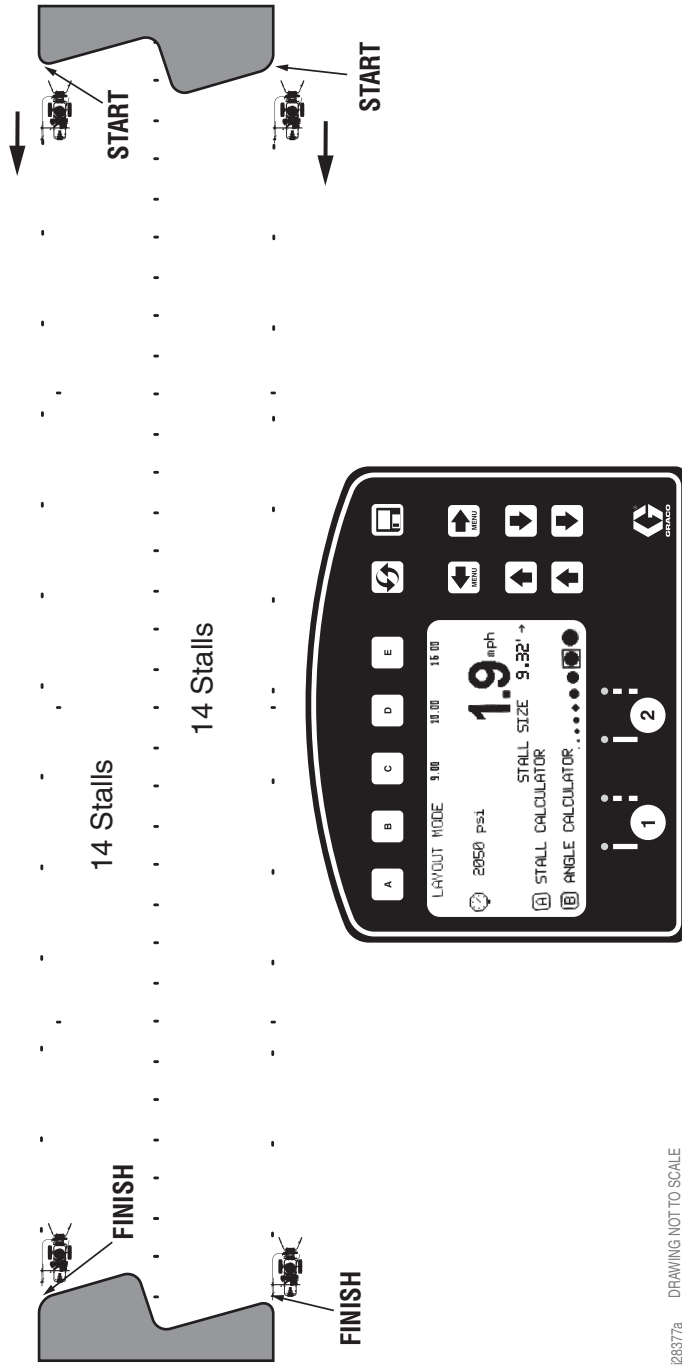

122377a DRAWING NOT TO SCALE

## LAYOUT MODE

Set gun to active. Press **GUN TRIGGER CONTROL** to **START** and **FINISH** dots.

If necessary, use **STALL CALC** to determine how many 9.32 ft parking stalls will fit.

# Angle Stall Layout: Striping Mode

Paint lines (connect the dots)

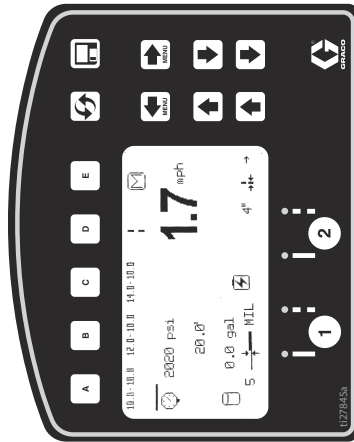
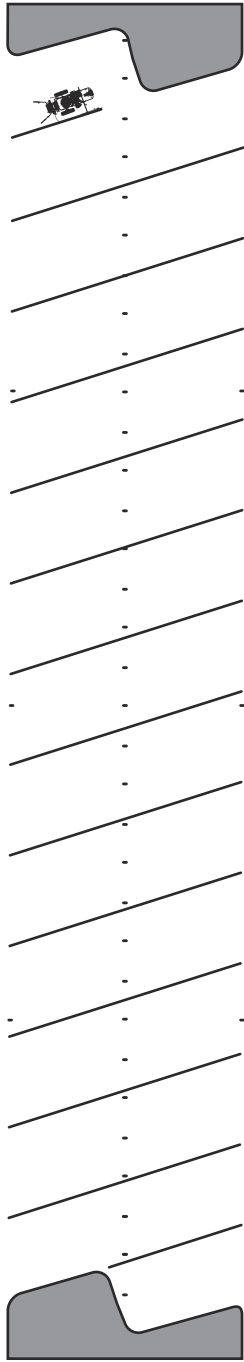

128378a DRAWING NOT TO SCALE

**STRIPING MODE**  
Simply connect the dots with the striper.

# Cross Hatch Layout: Layout Mode

Establish the boundary and apply dots at desired spacing

**NOTE:** For Best results, always dot in the same direction.

**NOTE:** Minimum RPM for placing dots is 2600.

**NOTE:** Minimum pressure on LLV 250SPS & 250DC is 1000 psi.

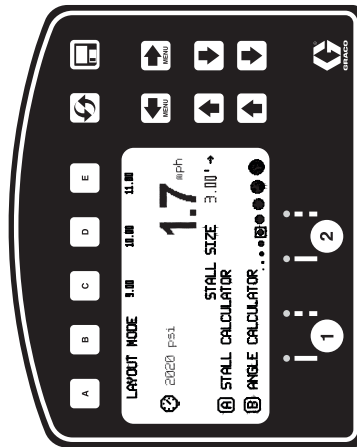
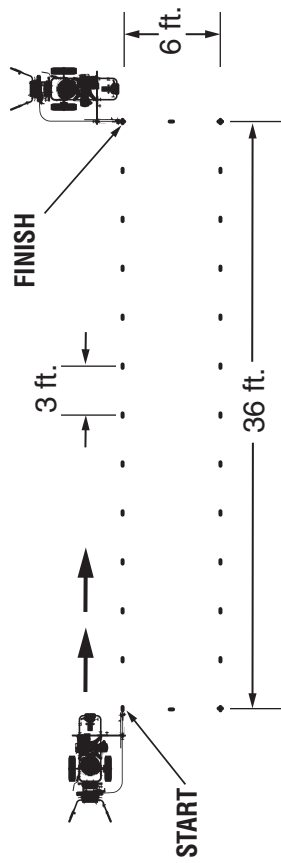

DRAWING NOT TO SCALE  
128379a

## LAYOUT MODE

Set gun to active. Press **GUN TRIGGER CONTROL** to **START** and **FINISH** dots.

Adjust **STALL SIZE** to achieve desired cross hatch spacing.

Place dots around perimeter of area.



# Cross Hatch Layout: Striping Mode

Paint lines (connect the dots)

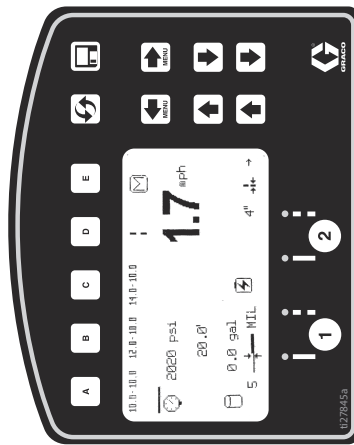
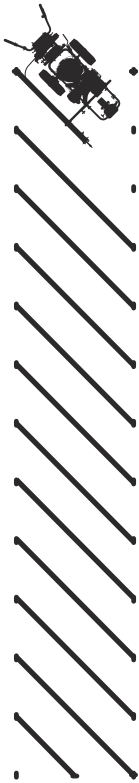

DRAWING NOT TO SCALE  
1128300a

## STRIPING MODE

Simply connect the dots with the striper.

Paint interior by connecting the dots. If ends are rounded as shown, make sure you establish this before painting.

# Cross Hatch Layout: Striping Mode

Paint perimeter (connect the dots)

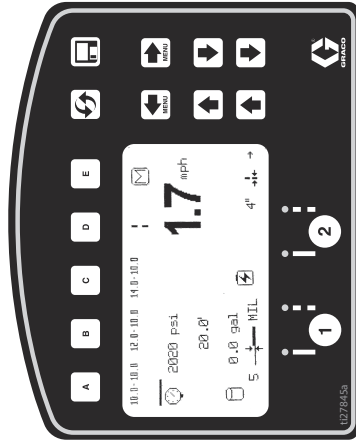
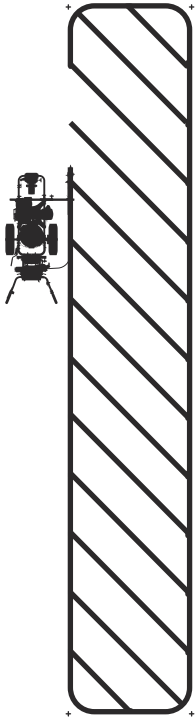

DRAWING NOT TO SCALE  
t28381a

## STRIPING MODE

Large or small, cross hatching jobs can be simplified by following these simple steps, eliminating the inconsistencies found on many job sites today.

# Marker Mode Layout: Center Lines and Lane Lines Mode

Paint lines (connect the dots)

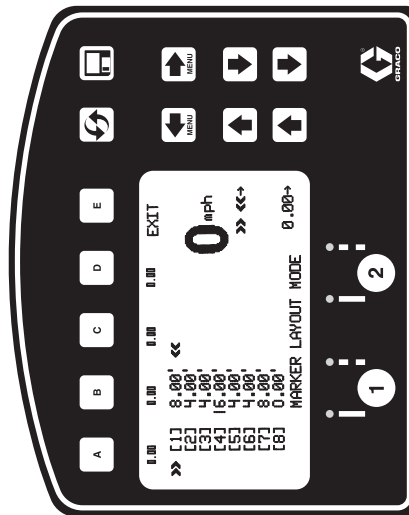
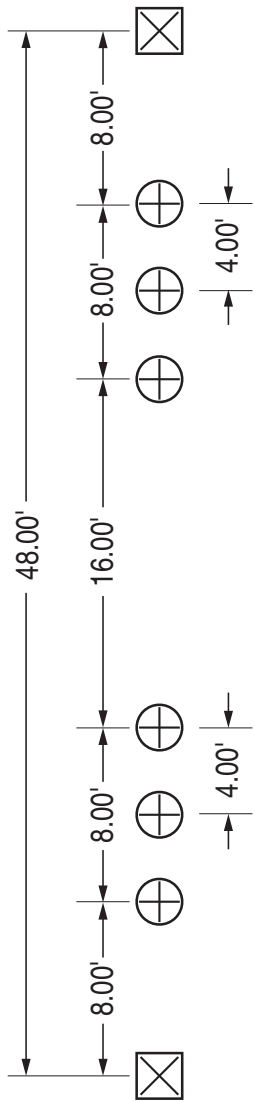

128382a

## MARKER MODE

Automatic marker layout example shows typical lane line layout for reflective markers. Set space sizes up to 8 consecutive measurements. By leaving zeros in any space, AutoLayout will skip to the next measurement in a continuous loop.

## OTHER USES:

- Multiple spaced handicap stall layout
- Double line stalls

# Notes

# Graco Standard Warranty

Graco warrants all equipment referenced in this document which is manufactured by Graco and bearing its name to be free from defects in material and workmanship on the date of sale to the original purchaser for use. With the exception of any special, extended, or limited warranty published by Graco, Graco will, for a period of twelve months from the date of sale, repair or replace any part of the equipment determined by Graco to be defective. This warranty applies only when the equipment is installed, operated and maintained in accordance with Graco's written recommendations.

This warranty does not cover, and Graco shall not be liable for general wear and tear, or any malfunction, damage or wear caused by faulty installation, misapplication, abrasion, corrosion, inadequate or improper maintenance, negligence, accident, tampering, or substitution of non-Graco component parts. Nor shall Graco be liable for malfunction, damage or wear caused by the incompatibility of Graco equipment with structures, accessories, equipment or materials not supplied by Graco, or the improper design, manufacture, installation, operation or maintenance of structures, accessories, equipment or materials not supplied by Graco.

This warranty is conditioned upon the prepaid return of the equipment claimed to be defective to an authorized Graco distributor for verification of the claimed defect. If the claimed defect is verified, Graco will repair or replace free of charge any defective parts. The equipment will be returned to the original purchaser transportation prepaid. If inspection of the equipment does not disclose any defect in material or workmanship, repairs will be made at a reasonable charge, which charges may include the costs of parts, labor, and transportation.

**THIS WARRANTY IS EXCLUSIVE, AND IS IN LIEU OF ANY OTHER WARRANTIES, EXPRESS OR IMPLIED, INCLUDING BUT NOT LIMITED TO WARRANTY OF MERCHANTABILITY OR WARRANTY OF FITNESS FOR A PARTICULAR PURPOSE.**

Graco's sole obligation and buyer's sole remedy for any breach of warranty shall be as set forth above. The buyer agrees that no other remedy (including, but not limited to, incidental or consequential damages for lost profits, lost sales, injury to person or property, or any other incidental or consequential loss) shall be available. Any action for breach of warranty must be brought within two (2) years of the date of sale.

**GRACO MAKES NO WARRANTY, AND DISCLAIMS ALL IMPLIED WARRANTIES OF MERCHANTABILITY AND FITNESS FOR A PARTICULAR PURPOSE, IN CONNECTION WITH ACCESSORIES, EQUIPMENT, MATERIALS OR COMPONENTS SOLD BUT NOT MANUFACTURED BY GRACO.** These items sold, but not manufactured by Graco (such as electric motors, switches, hose, etc.), are subject to the warranty, if any, of their manufacturer. Graco will provide purchaser with reasonable assistance in making any claim for breach of these warranties.

In no event will Graco be liable for indirect, incidental, special or consequential damages resulting from Graco supplying equipment hereunder, or the furnishing, performance, or use of any products or other goods sold hereto, whether due to a breach of contract, breach of warranty, the negligence of Graco, or otherwise.

## Graco Information

For the latest information about Graco products, visit [www.graco.com](http://www.graco.com).

For patent information, see [www.graco.com/patents](http://www.graco.com/patents).

**TO PLACE AN ORDER**, contact your Graco distributor or call 1-800-690-2894 to identify the nearest distributor.

*All written and visual data contained in this document reflects the latest product information available at the time of publication. Graco reserves the right to make changes at any time without notice.*

Original instructions. This manual contains English. MM 3A3428

**Graco Headquarters:** Minneapolis

**International Offices:** Belgium, China, Japan, Korea

**GRACO INC. AND SUBSIDIARIES • P.O. BOX 1441 • MINNEAPOLIS MN 55440-1441 • USA**  
**Copyright 2016, Graco Inc. All Graco manufacturing locations are registered to ISO 9001.**

[www.graco.com](http://www.graco.com)

Revision B, August 2019