

## E60/E50 King™ Electric Driver

3A8124A  
EN

---

Electric driver for application of finishing materials and protective coatings using King Sprayers.  
For professional use only.



### Important Safety Instructions

Read all warnings and instructions in this manual and the system manual before using the equipment. Save all instructions.

*See pages 3 for model and approvals information.*

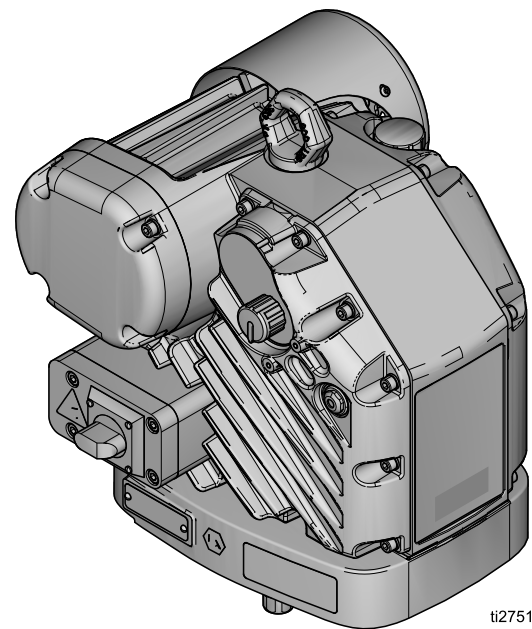

ti27514a

# Contents

Model Information.....	2	Error Code Troubleshooting .....	10
Driver Model.....	2	Standby Mode .....	10
Related Manuals .....	2	Error Codes Table.....	10
Warnings .....	3	Repair.....	12
Component Identification.....	6	Replace Output Seal Cartridge .....	12
Setup.....	7	Software Token Update.....	13
Install Vented Oil Cap Before Using		Control Board Replacement (273261) .....	14
Equipment.....	7	Encoder Replacement (25C169) .....	16
Grounding .....	7	Position Sensor Replacement	
Operation.....	8	(24W120).....	19
Startup .....	8	Notes .....	21
Shutdown.....	8	Parts.....	22
Pressure Relief Procedure.....	8	Driver Assembly: 24X960.....	22
Driver Operation .....	9	Repair Kits and Accessories.....	24
Pressure Control.....	9	Mounting Hole Pattern .....	25
Maintenance .....	9	Wiring Schematic.....	26
Preventive Maintenance Schedule .....	9	Technical Specifications.....	27
Change the Oil.....	9	Graco Extended Warranty .....	28
Check Oil Level .....	9		
Bearing Pre-Load.....	9		

## Model Information

### Driver Model

Part	Series	Description
24X960	A	King Driver

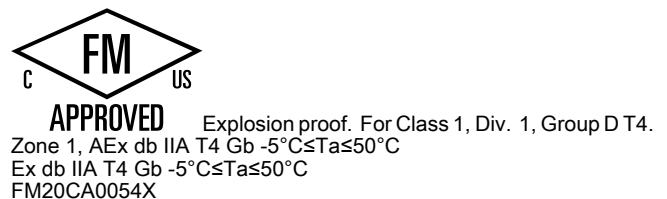
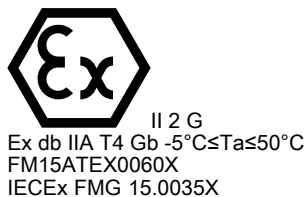







## Related Manuals











Manuals are available at [www.graco.com](http://www.graco.com).  
Component manuals in English:





Manuals in English	Description
3A8119	King E50/E60 Electric Driver Installation
3A8126	King E60/E50 Electric Sprayer
311619	Pump Mounting Kit Manual

# Warnings

The following warnings are for the setup, use, grounding, maintenance, and repair of this equipment. The exclamation point symbol alerts you to a general warning and the hazard symbols refer to procedure-specific risks. When these symbols appear in the body of this manual or on warning labels, refer back to these Warnings. Product-specific hazard symbols and warnings not covered in this section may appear throughout the body of this manual where applicable.

 <h2 style="margin: 0;">WARNING</h2>	
    	<p><b>FIRE AND EXPLOSION HAZARD</b></p> <p>Flammable fumes, such as solvent and paint fumes, in <b>work area</b> can ignite or explode. Paint or solvent flowing through the equipment can cause static sparking. To help prevent fire and explosion:</p> <ul style="list-style-type: none"> <li>• Use equipment only in well ventilated area.</li> <li>• Eliminate all ignition sources; such as pilot lights, cigarettes, portable electric lamps, and plastic drop cloths (potential static sparking).</li> <li>• Ground all equipment in the work area. See <b>Grounding</b> instructions.</li> <li>• Never spray or flush solvent at high pressure.</li> <li>• Keep work area free of debris, including solvent, rags and gasoline.</li> <li>• Do not plug or unplug power cords, or turn power or light switches on or off when flammable fumes are present.</li> <li>• Use only grounded hoses.</li> <li>• Hold gun firmly to side of grounded pail when triggering into pail. Do not use pail liners unless they are anti-static or conductive.</li> <li>• <b>Stop operation immediately</b> if static sparking occurs or you feel a shock. Do not use equipment until you identify and correct the problem.</li> <li>• Keep a working fire extinguisher in the work area.</li> </ul> <p>Static charge may build up on plastic parts during cleaning and could discharge and ignite flammable vapors. To help prevent fire and explosion:</p> <ul style="list-style-type: none"> <li>• Clean plastic parts only in well ventilated area.</li> <li>• Do not clean with a dry cloth.</li> <li>• Do not operate electrostatic guns in equipment work area.</li> </ul>
	<p><b>SPECIAL CONDITIONS FOR SAFE USE</b></p> <ul style="list-style-type: none"> <li>• To prevent the risk of electrostatic sparking, the equipment's non-metallic parts should be cleaned only with a damp cloth.</li> <li>• The aluminum housing may spark upon impact or contact with moving parts, which may cause fire or explosion. Take precautions to avoid such impact or contact.</li> <li>• All flameproof joints are critical to the integrity of the driver as approved for hazardous locations and are not repairable if damaged. Damaged parts must be replaced only with genuine Graco parts with no substitutions.</li> <li>• Consult Graco Technical Assistance or your Graco distributor if dimensional information on the flameproof joints is necessary.</li> <li>• Consult Graco Technical Assistance or your Graco distributor for genuine replacement fasteners. M8 x 30 socket-head cap screws of Class 12.9 steel or better with a minimum yield strength of 1100 MPa (160,000 psi) are acceptable alternatives. All socket-head cap screw cover fasteners must be torqued to 15 ft-lb (20.3 N•m).</li> </ul>

 <h1 style="margin: 0;">WARNING</h1>	
 	<p><b>ELECTRIC SHOCK HAZARD</b>                      This equipment must be grounded. Improper grounding, setup, or usage of the system can cause electric shock.</p> <ul style="list-style-type: none"> <li>• Turn off and disconnect power at main switch before disconnecting any cables and before servicing or installing equipment.</li> <li>• Connect only to grounded power source.</li> <li>• All electrical wiring must be done by a qualified electrician and comply with all local codes and regulations.</li> <li>• Do not expose to rain. Store indoors.</li> <li>• Wait five minutes before servicing after power is removed.</li> </ul>
	<p><b>BURN HAZARD</b>                      Equipment surfaces and fluid that is heated can become very hot during operation. To avoid severe burns:</p> <ul style="list-style-type: none"> <li>• Do not touch hot fluid or equipment.</li> </ul>
 	<p><b>MOVING PARTS HAZARD</b>                      Moving parts can pinch, cut or amputate fingers and other body parts.</p> <ul style="list-style-type: none"> <li>• Keep clear of moving parts.</li> <li>• Do not operate equipment with protective guards or covers removed.</li> <li>• Pressurized equipment can start without warning. Before checking, moving, or servicing equipment, follow the <b>Pressure Relief Procedure</b> and disconnect all power sources.</li> </ul>
    	<p><b>SKIN INJECTION HAZARD</b>                      High-pressure fluid from dispensing device, hose leaks, or ruptured components will pierce skin. This may look like just a cut, but it is a serious injury that can result in amputation. <b>Get immediate surgical treatment.</b></p> <ul style="list-style-type: none"> <li>• Do not spray without tip guard and trigger guard installed.</li> <li>• Engage trigger lock when not spraying.</li> <li>• Do not point gun at anyone or at any part of the body.</li> <li>• Do not put your hand over the spray tip.</li> <li>• Do not stop or deflect leaks with your hand, body, glove, or rag.</li> <li>• Follow the <b>Pressure Relief Procedure</b> when you stop spraying and before cleaning, checking, or servicing equipment.</li> <li>• Tighten all fluid connections before operating the equipment.</li> <li>• Check hoses and couplings daily. Replace worn or damaged parts immediately.</li> </ul>

 <h1 style="margin: 0;">WARNING</h1>	
	<p><b>TOXIC FLUID OR FUMES</b> Toxic fluids or fumes can cause serious injury or death if splashed in the eyes or on skin, inhaled, or swallowed.</p> <ul style="list-style-type: none"> <li>• Read Safety Data Sheets (SDSs) to know the specific hazards of the fluids you are using.</li> <li>• Store hazardous fluid in approved containers, and dispose of it according to applicable guidelines.</li> </ul>
	<p><b>PERSONAL PROTECTIVE EQUIPMENT</b> Wear appropriate protective equipment when in the work area to help prevent serious injury, including eye injury, hearing loss, inhalation of toxic fumes, and burns. Protective equipment includes but is not limited to:</p> <ul style="list-style-type: none"> <li>• Protective eyewear, and hearing protection.</li> <li>• Respirators, protective clothing, and gloves as recommended by the fluid and solvent manufacturer.</li> </ul>
 	<p><b>EQUIPMENT MISUSE HAZARD</b> Misuse can cause death or serious injury.</p> <ul style="list-style-type: none"> <li>• Do not operate the unit when fatigued or under the influence of drugs or alcohol.</li> <li>• Do not exceed the maximum working pressure or temperature rating of the lowest rated system component. See <b>Technical Specifications</b> in all equipment manuals.</li> <li>• Use fluids and solvents that are compatible with equipment wetted parts. See <b>Technical Specifications</b> in all equipment manuals. Read fluid and solvent manufacturer's warnings. For complete information about your material, request Safety Data Sheets (SDSs) from distributor or retailer.</li> <li>• Do not leave the work area while equipment is energized or under pressure.</li> <li>• Turn off all equipment and follow the <b>Pressure Relief Procedure</b> when equipment is not in use.</li> <li>• Check equipment daily. Repair or replace worn or damaged parts immediately with genuine manufacturer's replacement parts only.</li> <li>• Do not alter or modify equipment. Alterations or modifications may void agency approvals and create safety hazards.</li> <li>• Make sure all equipment is rated and approved for the environment in which you are using it.</li> <li>• Use equipment only for its intended purpose. Call your distributor for information.</li> <li>• Route hoses and cables away from traffic areas, sharp edges, moving parts, and hot surfaces.</li> <li>• Do not kink or over bend hoses or use hoses to pull equipment.</li> <li>• Keep children and animals away from work area.</li> <li>• Comply with all applicable safety regulations.</li> </ul>

# Component Identification

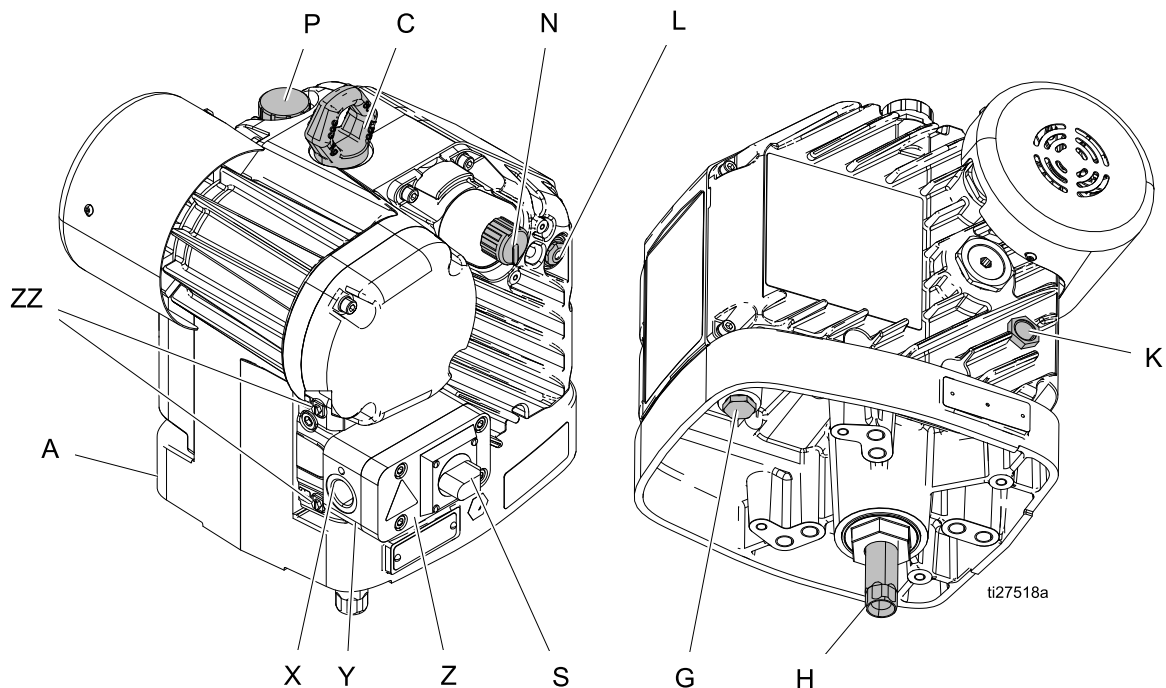





Ref.	Description
A	Driver
B*	Fused Safety Switch (not shown)
C	Lift Ring
G	Oil Drain Plug
H	Driver Output Shaft
K	Oil Sight Glass
L	Status Indicator Light (LED)
N	Pressure Control Knob
P**	Oil Fill Cap (vented)
S	Power Switch (Lock-out tag-out equipped)
Y	Electrical Junction Box
X	Conduit Entry
Z	Electrical Junction Box Cover
ZZ	Ground Screws

\* The driver requires a dedicated circuit protected by a circuit breaker or fused safety switch. See Driver Installation manual for details.

\*\* The driver ships pre-filled with oil from the factory. The temporary unvented cap is for shipping purposes only and must be replaced with the supplied vented cap before use.

## Setup

See Driver Installation manual for power requirements for hazardous locations/explosive atmospheres.



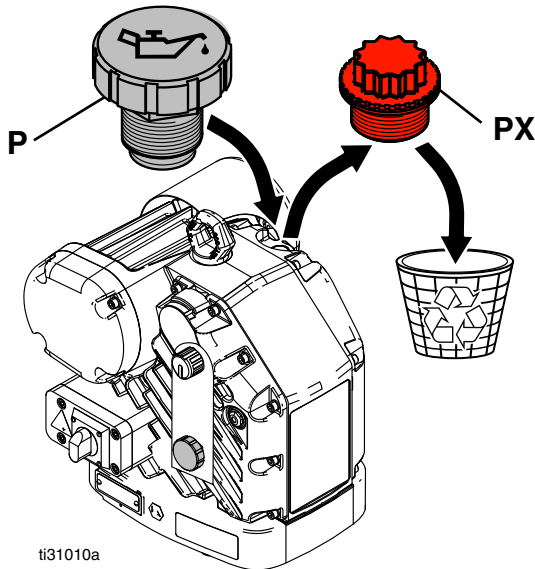

				
<p>Installation of this equipment involves potentially hazardous procedures. Only trained and qualified personnel who have read and who understand the information in this manual should install this equipment.</p>				

### Install Vented Oil Cap Before Using Equipment

The temporary unvented cap (PX) prevents oil leaks during shipment. This temporary cap must be replaced with the supplied vented oil cap (P) before use.



## Grounding

				
<p>This equipment must be grounded to reduce the risk of static sparking and electric shock. Electric or static sparking can cause fumes to ignite or explode. Improper grounding can cause electric shock. Grounding provides an escape wire for the electric current.</p>				

**Driver:** The driver is grounded through the power cord.

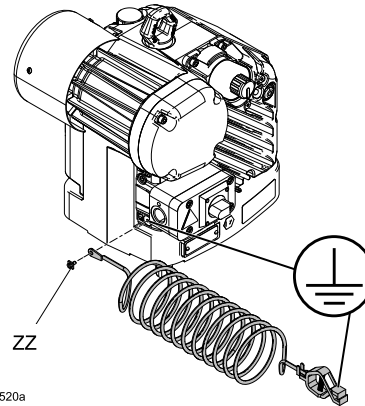

**Driver (optional secondary):** Two ground terminals are provided if local code requires redundant grounding connections.

Loosen the ground screw (ZZ) and attach a ground wire (Graco part 244524 - not supplied). Tighten the ground screw securely. Connect the other end of the ground wire to a true earth ground.

# Operation

## Startup

1. Unlock the fused safety switch (B) and turn it on.
2. Turn the power switch (S) ON.
3. Check that the status indicator (L) is lit (steady on).

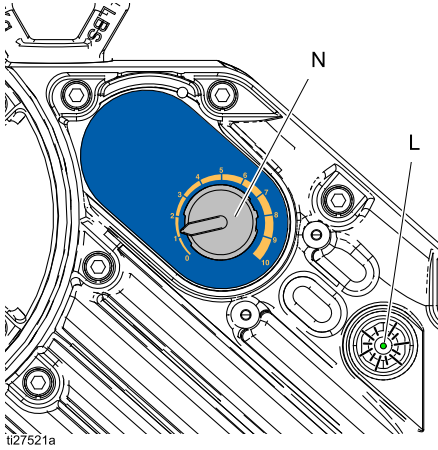





## Shutdown

Follow the **Pressure Relief Procedure**.

## Pressure Relief Procedure



Follow the Pressure Relief Procedure whenever you see this symbol.

				
<p>This equipment stays pressurized until pressure is manually relieved. To help prevent serious injury from moving parts or pressurized fluid, such as skin injection, follow the Pressure Relief Procedure when you stop spraying and before cleaning, checking, or servicing the equipment.</p>				

1. Turn the power switch (S) OFF.
2. Shut off and lock out the fused safety switch (B).
3. Relieve all fluid pressure as explained in your separate system manual.



# Driver Operation

## Pressure Control

The driver will adjust the speed to maintain a constant fluid pressure.

1. Pull the Pressure Control Knob (N) out to set.
2. Turn the Pressure Control Knob (N) fully counterclockwise to 0.
3. Turn the knob clockwise to increase the pressure, or counterclockwise to decrease the pressure. Push the knob in to lock.

## Maintenance

### Preventive Maintenance Schedule

The operating conditions of your particular system determine how often maintenance is required. Establish a preventive maintenance schedule by recording when and what kind of maintenance is needed, and then determine a regular schedule for checking your system.

### Change the Oil

**NOTE:** Change the oil after a break-in period of 200,000–300,000 cycles. After the break-in period, change the oil once a year. Order two bottles of Silicone-Free Synthetic ISO 220 EP Gear Oil (Graco Part No. 16W645).

1. Place a minimum 2 quart (1.9 liter) container under the oil drain port. Remove the oil drain plug (G). Allow all oil to drain from the driver.
2. Reinstall the oil drain plug (G). Torque to 18–23 ft-lb (25–30 N•m).

### NOTICE

Do not over-torque. The drain plug can become stripped and damaged.

3. Open the fill cap (P) and add Graco Part No. 16W645 Silicone-Free Synthetic ISO 220 EP Gear Oil. Check the oil level in the sight glass (K). Fill until the oil level is near the halfway point of the sight glass. The oil capacity is approximately 1.–1.2 quarts (0.9–1.1 liters). **Do not overfill.**

### NOTICE

Only use Graco GBL oil (Graco part number 16W645). Any other oil may not lubricate properly and can cause damage to the drive train.

4. Reinstall the fill cap.

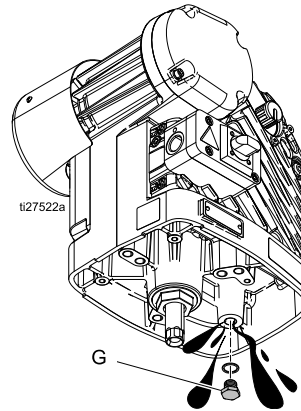

### Check Oil Level

Check the oil level in the sight glass (K). The oil level should be near the halfway point of the sight glass when the unit is not running. If low, open the fill cap (P) and add Graco Part No. 16W645 Silicone-Free Synthetic ISO 220 EP Gear Oil as required. The oil capacity is approximately 1.0–1.2 quarts (0.9–1.1 liters). **Do not overfill.**

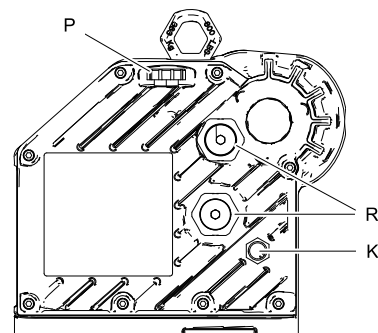

### Bearing Pre-Load

The bearing pre-loads (R) are factory set and are not user adjustable. Do not adjust the bearing pre-loads.

# Error Code Troubleshooting

Error codes can take two forms:

- **Alarm:** Alerts you to the cause of the alarm and shuts down the driver.
- **Deviation:** Alerts you to the problem, but the driver may continue to run past the set limits until the system absolute limits are reached.

**NOTE:** The blink code is displayed using the status indicator (L) on the driver. The blink code given below indicates the sequence. For example, blink code 2 indicates two blinks, a pause, and then repeats.

**NOTE:** To clear an error code, cycle power by turning the power switch (S) to the OFF position for at least 30 seconds before turning back ON.

## Standby Mode

When slow blinking is displayed, the driver has entered Standby Mode. When the driver is on and pressurized but the pump has not moved any material, the driver will enter Standby Mode.

Standby Mode will be exited when:







- Material starts to dispense and causes the pump to move, OR
- The pressure control knob (N) is adjusted, OR
- The power switch (S) is cycled OFF and ON

## Error Codes Table

Blink Code	Error Type	Troubleshooting Steps
1	Alarm	<p><b>Pump diving</b></p> <p>The pump is diving rapidly. A pressure imbalance between the up and down stroke of the pump is causing the pump to dive with excessive speed.</p> <ul style="list-style-type: none"> <li>• Pump diving may occur when the pump runs out material while spraying at high pressure.</li> <li>• Verify that material is being properly fed to the pump.</li> <li>• Pressure from the hose could flow back into the pump on the down stroke.</li> <li>• Verify that the check valve is installed and is properly working.</li> </ul>
2	Alarm	<p><b>Voltage Too Low</b></p> <ul style="list-style-type: none"> <li>• Verify that line voltage is within the range specified in <a href="#">Technical Specifications, page 27</a>.</li> <li>• Cycle power and check status indicator (L) to see if the error is still active.</li> </ul>
3	Alarm	<p><b>Voltage Too High</b></p> <ul style="list-style-type: none"> <li>• Verify that line voltage is within the range specified in <a href="#">Technical Specifications, page 27</a>.</li> <li>• Cycle power and check status indicator (L) to see if the error is still active.</li> </ul>
4	Deviation	<p><b>High Temperature</b></p> <p>The temperature of the system is near the maximum operation temperature. The performance has been reduced to prevent the driver from completely shutting down.</p> <ul style="list-style-type: none"> <li>• Check fan operation. Clean the fan and driver housing.</li> <li>• Reduce pressure, duty cycle, or gun tip size.</li> <li>• Move the unit to a cooler location.</li> </ul>
5	Deviation	<p><b>Low Temperature</b></p> <ul style="list-style-type: none"> <li>• Warm equipment.</li> </ul>

Blink Code	Error Type	Troubleshooting Steps
6	Alarm	<p><b>Motor Temperature Fault</b></p> <p>Motor is running too hot. Allow unit to cool.</p> <ul style="list-style-type: none"> <li>• Check fan operation. Clean the fan and driver housing.</li> <li>• Reduce pressure, duty cycle, or gun tip size.</li> <li>• Move the unit to a cooler location.</li> </ul>
7	Alarm	<p><b>Board Temperature Fault</b></p> <p>The control board is running too hot. Allow the unit to cool.</p> <ul style="list-style-type: none"> <li>• Check fan operation. Clean the fan and driver housing.</li> <li>• Reduce pressure, duty cycle, or gun tip size.</li> <li>• Move the unit to a cooler location.</li> </ul>
8	Alarm	<p><b>Encoder Calibration Error</b></p> <ul style="list-style-type: none"> <li>• Cycle power and check status indicator (L) to see if the error is still active.</li> <li>• Calibrate the encoder (this code will blink if calibration is in progress).</li> <li>• See <b>Graco Contact Information</b> ( <a href="#">Graco Extended Warranty, page 28</a>).</li> </ul>
9	Alarm	<p><b>Encoder Error</b></p> <ul style="list-style-type: none"> <li>• Cycle power and check the status indicator (L) to see if the error is still active.</li> <li>• Verify that the encoder cable (EE) is connected securely (see <a href="#">Wiring Schematic, page 26</a>).</li> <li>• The encoder may need replacement.</li> <li>• See <b>Graco Contact Information</b> ( <a href="#">Graco Extended Warranty, page 28</a>).</li> </ul>
10	Alarm	<p><b>Software Versions Do Not Match</b></p> <ul style="list-style-type: none"> <li>• See the system manual for software token part number.</li> <li>• Obtain software update token and follow <b>Software Update</b> procedure.</li> </ul>
11	Alarm	<p><b>Circuit Board Communication Failure</b></p> <ul style="list-style-type: none"> <li>• Cycle power and check status indicator (L) to see if the error is still active.</li> <li>• See <b>Graco Contact Information</b> ( <a href="#">Graco Extended Warranty, page 28</a>).</li> </ul>
12	Alarm	<p><b>Internal Circuit Board Hardware Failure</b></p> <ul style="list-style-type: none"> <li>• Cycle power and check status indicator (L) to see if the error is still active.</li> <li>• See <b>Graco Contact Information</b> ( <a href="#">Graco Extended Warranty, page 28</a>).</li> </ul>
13, 14	Alarm	<p><b>Internal Software Error</b></p> <ul style="list-style-type: none"> <li>• Cycle power and check status indicator (L) to see if the error is still active.</li> <li>• See <b>Graco Contact Information</b> ( <a href="#">Graco Extended Warranty, page 28</a>).</li> </ul>
Slow Blink	Deviation	See <a href="#">Standby Mode, page 10</a> .

# Repair

To avoid electric shock, fire and explosion hazard, and/or injury from moving parts hazard, turn off equipment power and shut off power at the main circuit breaker before repairing. Wear appropriate protective equipment when in work area. Wait five minutes before servicing.



Make sure wires are not pinched when re-installing covers. Wires will be damaged and create an electrical hazard and/or fire and explosion hazard if pinched.

**NOTE:** Consult Graco Technical Assistance or your Graco distributor for genuine replacement fasteners. M8 x 30 socket-head cap screws of Class 12.9 steel or better with a minimum yield strength of 1100 MPa (160,000 psi) are acceptable alternatives.

## Replace Output Seal Cartridge

1. Stop the pump at the bottom of its stroke. Shut off and lock out power to the driver.
2. Follow the [Pressure Relief Procedure, page 8](#) .
3. Disconnect the pump lower from the driver, as explained in your separate system manual.
4. Drain the oil from the driver. See [Change the Oil, page 9](#) .
5. Reinstall the oil drain plug. Torque to 18–23 ft-lb (25–30 N•m).
6. Unscrew the output cartridge (19) from the driver. See [Parts, page 22](#).
7. Install the new output cartridge. Torque to 175–200 ft-lb (240–280 N•m).
8. Fill with oil. See [Change the Oil, page 9](#) .
9. Reconnect the pump lower to the driver.
10. Turn on power and resume operation.

## Software Token Update

				
<p>To help prevent fire and explosion, do not connect, download, or remove the token unless the unit is removed from the hazardous (explosive atmosphere) location.</p>				

1. Turn the disconnect switch OFF. Remove power from the unit.
2. Use a 6 mm hex wrench to remove four bolts. Remove the motor cover.

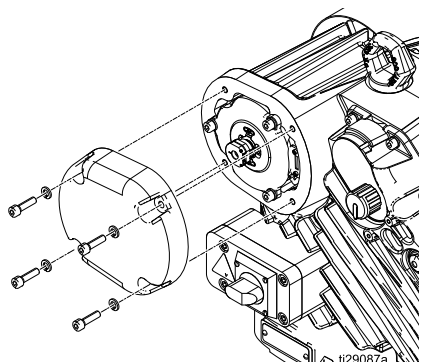

3. Insert and press the token firmly into the token connector slot. **NOTE:** The token requires no specific orientation.

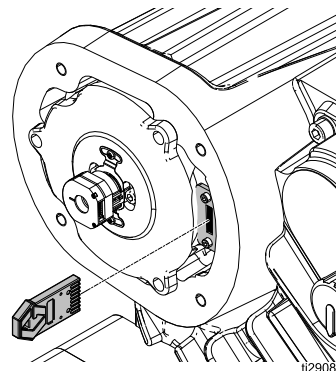

4. Reinstall the motor cover.
5. Apply power and turn the disconnect switch ON.
6. Monitor the Status Indicator Light (L) for the status of the software update.
  - a. The Status Indicator Light will blink slowly for a few seconds and then rapidly for several seconds.
  - b. Once the update is complete, the unit will power up and flash out the software version. Three numbers will be flashed out to convey the software version in the format of x.yy.zzz. For example: "flash-pause-flash-flash-pause-flash-pause" would indicate that software version is 1.02.001 installed.
7. The unit will flash out the software version every time the unit is powered up while the software token is present. The token can remain in place even after the software has been updated, but can optionally be removed.
8. Contact Graco Technical Support for the latest software version for each system.

## Control Board Replacement (273261)

### NOTICE

To avoid damage to the electric components, wear grounding strap (Graco Part No. 112190 – not supplied) and ground appropriately.

### Overview

The main control board assembly manages the operation of the driver. It is permanently attached to the electronics cover.

### Tools Required

- 6 mm Hex Wrench
- Phillips Screwdriver (#1)
- Torque Wrench (15 ft-lb, 20 N•m)

### Prepare Driver

1. Remove power from the driver. Follow appropriate lock-out/tag-out procedures. Wait five minutes before servicing.
2. Follow the [Pressure Relief Procedure, page 8](#).
3. Decouple the pump lower from the driver per the system manual.

### Disconnect Power Wires

1. Remove the screws (J) and junction box cover (Z) from the electrical junction box (Y). Remove screw (Ys) and sleeve housing.
2. Disconnect wires from terminal bushings L1 and L2.
3. Remove the ground lug and disconnect the green ground wire.
4. Disconnect wires from the opposite side of the disconnect in terminals labeled 2T1 and 4T2.

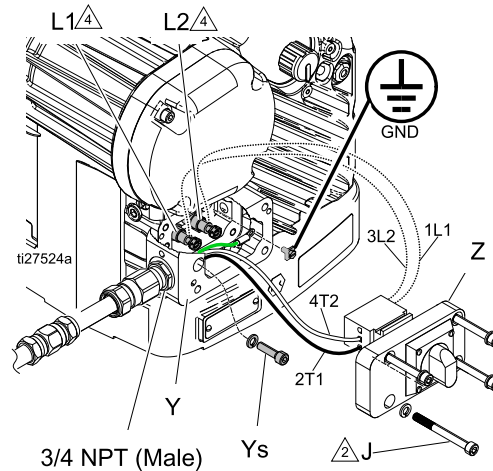

## Remove Electronics Cover

### NOTICE

To avoid equipment damage, carefully support the cover when removing the last bolt. Hold the cover horizontally and take care that the wires are not pulled tight.

1. Remove the 12 bolts (CB) that hold on the electronics cover using a 6 mm hex wrench. Place bolts in a safe location.
2. Pull the cover straight off of the alignment pins that hold the cover in place.
3. Support the cover after it has been removed to prevent putting excess strain on the wires inside.

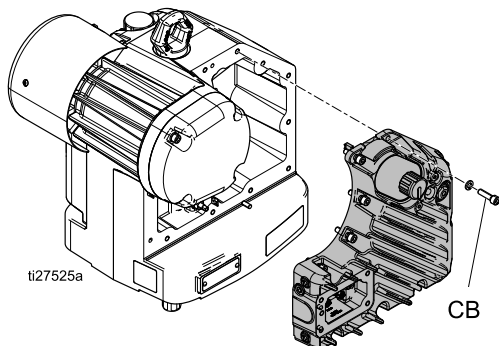

## Disconnect Control Board

**NOTE:** The control board is inside the electronics cover. To replace the control board the entire electronics cover must be replaced.

1. To disconnect the control board unplug all connectors from the control board (see [Wiring Schematic, page 26](#)).
2. Remove motor wires from clip inside housing (see [Wiring Schematic, page 26](#)).
3. Set the electronics cover/control board aside.

## Reinstall Electronics Cover onto Driver

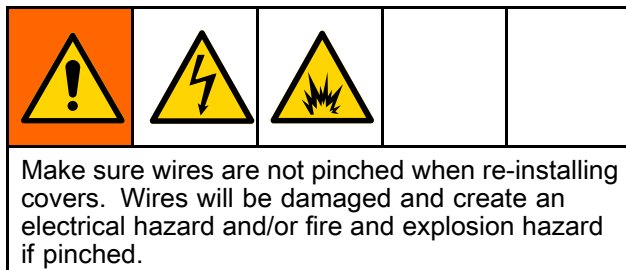

1. Plug in all connectors. Ensure all connectors are securely attached to the control board. See [Wiring Schematic, page 26](#).
2. Secure loose motor wires into the clip inside the housing (see [Wiring Schematic, page 26](#)).
3. Reinstall electronics cover onto center housing.
4. Install the 12 bolts using a 6 mm hex wrench. **NOTE:** Ensure the lock washers are still in place.
5. Torque the bolts to 15 ft-lb (20 N•m).

## Power Unit — Run Calibration Procedure

**NOTE:** The driver must be de-coupled from the pump lower and must be able to cycle freely with no obstructions.

1. Cycle power to the driver by first turning the power switch (S) OFF, and then ON again.
2. Wait for the status indicator LED (L) to turn on solid or start blinking.
3. Within 30 seconds, rapidly turn the pressure control knob (N) back and forth from 0 to 10 at least five times and then set the knob back to 0. If the status indicator LED (L) was solid before, it will begin blinking an encoder calibration error (code 8) during the calibration process.
4. The driver output shaft (H) will run up and down slowly over the course of several minutes.
5. Midway through the auto-calibration process the driver output shaft (H) will pause as it moves to the next step.
6. The driver output shaft (H) will move up and down faster 5–6 times.
7. Ensure the auto-calibration process is complete before continuing (wait for the LED to stop blinking).

## Reattach Pump Lower

See the system manual.

## Encoder Replacement (25C169)

### NOTICE

To avoid damage to the electronic components, wear grounding strap (Graco Part No. 112190) and ground appropriately.

### Overview

The encoder is used by the driver for two purposes. First, the encoder tells the control board where the motor is in its mechanical rotation and uses that information to properly control the motor torque. Second, it controls stroke length by allowing the control board to count the number of complete motor rotations.

### Tools Required

- 6 mm Hex Wrench
- 0.050 in Hex Wrench
- Phillips Screwdriver (#1)
- Torque Wrench (15 ft-lb, 20 N•m)
- Blue (medium) thread locking compound

### Prepare Driver

1. Remove power from the driver. Follow appropriate lock-out/tag-out procedures. Wait five minutes before servicing.
2. Follow the [Pressure Relief Procedure, page 8](#).
3. Decouple the pump lower from the driver per the system manual.

### Remove Electronics Cover (When Also Replacing the Encoder Cable)

### NOTICE

To avoid equipment damage, carefully support the cover when removing the last bolt. Hold the cover horizontally and take care that the wires are not pulled tight.

1. Remove the 12 bolts (CB) that hold on the electronics cover using a 6 mm hex wrench. Place bolts in a safe location.
2. Pull the cover straight off of the alignment pins that hold the cover in place.
3. Support the cover after it has been removed to prevent putting excess strain on the wires inside.

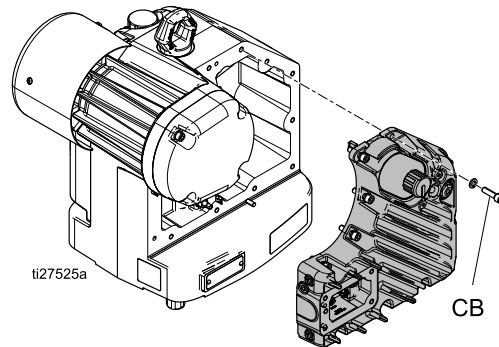



## Remove Motor Cover

1. Remove the 4 bolts that hold on the motor cover using a 6 mm hex wrench. Place bolts in a safe location.
2. Set motor cover aside.

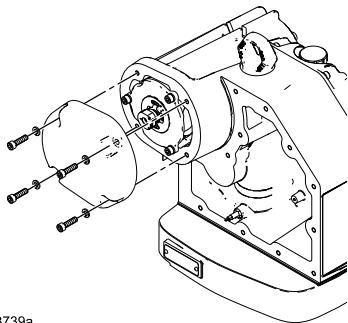

ti23739a

## Remove Encoder

1. If replacing the encoder cable also, unplug the encoder cable (AE/AF) from the control board and the encoder and remove.
2. Loosen the 2 hub set screws (AA) using the included 0.050" hex wrench.
3. Remove the 2 mounting screws (AC) with a Phillips head screwdriver.
4. Pull encoder (AB) off of rotor shaft.

**NOTE:** This procedure only requires the removal of the 2 Phillips head mounting screws. All other bolts should remain in place.

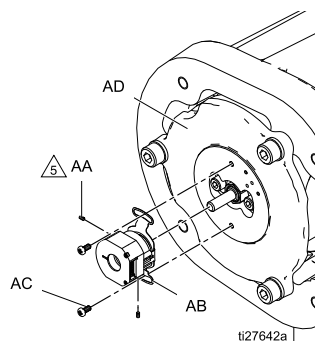

ti27642a

AA	Set screws $\triangle 5$ 50 +/- 5 in-oz (0.35 N•m).
AB	Encoder mounting flange
AC	Phillips head mounting screws
AD	Rotor Bearing Housing

## Install New Encoder

1. If replacing the encoder cable (AE/AF) also, place the encoder connector cable through the motor housing.

**NOTE:** The encoder connector (AE) end is the smaller of the two connectors.

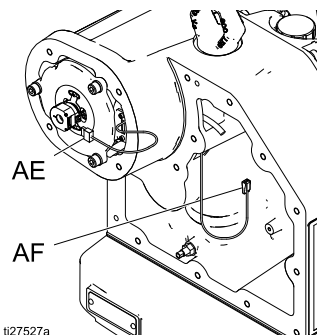



ti27527a

AE	Encoder connector (smaller)
AF	Control board connector (larger)

2. Slide the new encoder onto the rotor shaft.
3. Apply a small amount of blue (medium) thread locker to the 2 Phillips head mounting screws (AC) and secure encoder mounting flange (AB) to motor housing (AD).
4. Remove the 2 set screws (AA) from the encoder hub using the included 0.050 in. hex wrench.
5. Apply a small amount of blue (medium) thread locker to the set screws (AA) and screw back into the encoder. Tighten to 50 +/- 5 in-oz (0.35 N•m).
6. Plug encoder cable into the encoder (AE). If the encoder cable was also replaced, plug the other end into the control board (AF). See [Wiring Schematic, page 26](#).

### Reinstall Electronics Cover onto Driver (only if removed to replace the encoder cable)

				
<p>Make sure wires are not pinched when re-installing covers. Wires will be damaged and create an electrical hazard and/or fire and explosion hazard if pinched.</p>				

1. Plug in all connectors. Ensure all connectors are securely attached to the control board (see [Wiring Schematic, page 26](#)).
2. Secure loose motor wires into the clip inside the housing (see [Wiring Schematic, page 26](#)).
3. Reinstall electronics cover onto center housing.
4. Install the 12 bolts using a 6 mm hex wrench. **NOTE:** Ensure the lock washers are still in place.
5. Torque the bolts to 15 ft-lb (20 N•m).

### Reinstall Motor Cover

1. Reinstall motor cover onto driver housing.

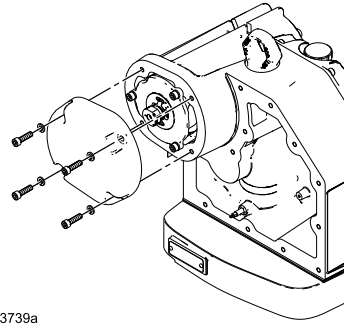

ti23739a

2. Install the four bolts and mounting lock washers that hold on the motor cover using a 6 mm hex wrench. Ensure the lock washers are still in place.
3. Torque the bolts to 15 ft-lb (20 N•m).
4. Follow the [Power Unit — Run Calibration Procedure, page 15](#).

### Reattach Pump Lower

See the system manual.

## Position Sensor Replacement (24W120)

### NOTICE

To avoid damage to the encoder and control board, wear grounding strap (Graco Part No. 112190 – not supplied) and ground appropriately.

### Overview

The position sensor is used to determine where the driver output shaft (H) is in the stroke.

### Tools Required

- 6 mm Hex Wrenches
- 13 mm Open-Ended Wrench
- 6 mm Open-Ended Wrench
- Phillips Screwdriver (#2)
- Torque Wrench (15 ft-lb, 20 N•m)

### Prepare Driver

1. Remove power from the driver. Follow appropriate lock-out/tag-out procedures. Wait five minutes before servicing.
2. Follow the [Pressure Relief Procedure, page 8](#).
3. Decouple the pump lower from the driver per the system manual.

### Remove Electronics Cover

### NOTICE

To avoid equipment damage, carefully support the cover when removing the last bolt. Hold the cover horizontally and take care that the wires are not pulled tight.

1. Remove the 12 bolts (CB) that hold on the electronics cover using a 6 mm hex wrench. Place bolts in a safe location.
2. Pull the cover straight off of the alignment pins that hold the cover in place.
3. Support the cover after it has been removed to prevent putting excess strain on the wires inside.

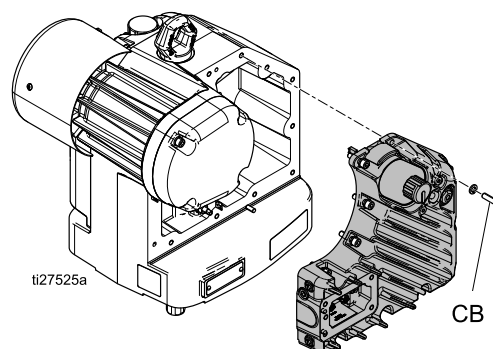

### Remove Position Sensor

1. Unplug the position sensor (AR) from the control board (see [Wiring Schematic, page 26](#)).
2. Loosen the position sensor jam nut (AS) using a 13 mm wrench.
3. Unscrew the position sensor (AR) from the center housing using a 6 mm open ended wrench.

**NOTE:** Allow wires to rotate with position sensor to prevent twisting.

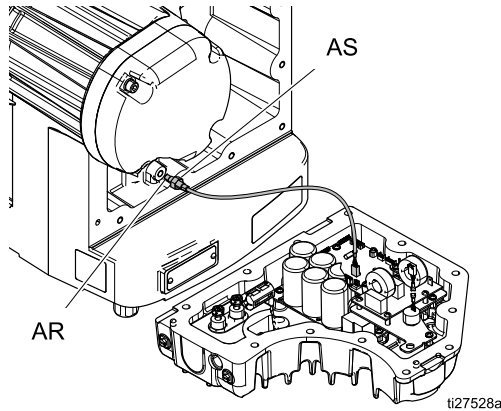

### Install New Position Sensor

1. Carefully screw the replacement position sensor into the center housing.  
**NOTE:** Be careful not to damage the wires. The wires will have to be rotated while the position sensor is installed to prevent them from being twisted.
2. Use the 6 mm wrench to complete the installation of the position sensor. Be careful not to use excessive torque. Stop once the position sensor bottoms out in the bore.

**NOTICE**  
Do not over tighten the position sensor. Damage to the position sensor may result.

3. Tighten the jam nut on the position sensor finger tight.

**NOTICE**  
Do not use a wrench to tighten the jam nut. Damage to the position sensor may result.

4. Plug the position sensor into the control board (see [Wiring Schematic, page 26](#)).
5. Reset the dip switch.

### Reinstall Electronics Cover onto Driver

Make sure wires are not pinched when re-installing covers. Wires will be damaged and create an electrical hazard and/or fire and explosion hazard if pinched.				

1. Plug in all connectors. Ensure all connectors are securely attached to the control board. See [Wiring Schematic, page 26](#).
2. Secure loose motor wires into the clip inside the housing (see [Wiring Schematic, page 26](#)).
3. Reinstall electronics cover onto center housing.
4. Install the 12 bolts using a 6 mm hex wrench.  
**NOTE:** Ensure the lock washers are still in place.
5. Torque the bolts to 15 ft-lb (20 N•m).

### Reattach Pump Lower

See the system manual.





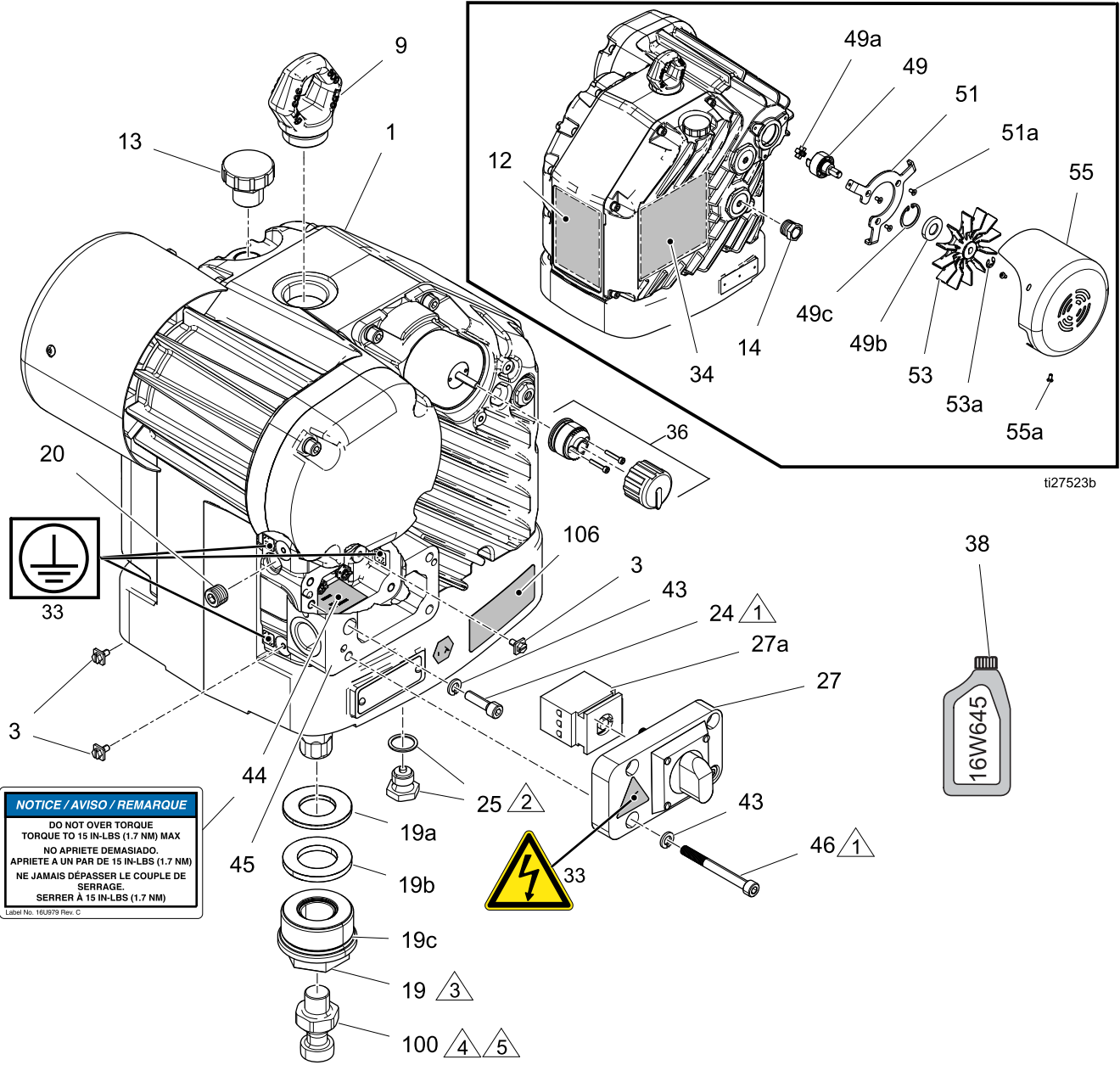

# Parts

## Driver Assembly: 24X960



**NOTICE / AVISO / REMARQUE**  
 DO NOT OVER TORQUE  
 TORQUE TO 15 IN-LBS (1.7 NM) MAX  
 NO APRIETE DEMASIADO.  
 APRIETE A UN PAR DE 15 IN-LBS (1.7 NM)  
 NE JAMAIS DÉPASSER LE COUPLE DE  
 SERRAGE.  
 SERRER À 15 IN-LBS (1.7 NM)  
 Label No. 16U979 Rev. C

Ref.	Part	Description	Qty.	Ref.	Part	Description	Qty.
1	— — —	HOUSING, driver	1	44	16U979	LABEL, torque spec	1
3	116343	SCREW, ground; M5 x 0.8	3	45	25C171	KIT, housing, junction box	1
9	15F931	RING, lift	1	46*	25C170	SCREW, shcs; M8 x 1.25; 80 mm (4-pack)	4
12	— — —	LABEL, branding, E60	1	49	17M815	KIT, fan bearing with coupler	1
	— — —	LABEL, branding, E50	1	49a	— — —	COUPLER	1
13	15H525	CAP, oil fill	1	49b	25C182	KIT, seal, input shaft	1
14	24E315	SIGHT GLASS	1	49c	119539	RING, retaining, internal	1
19	25C164	CARTRIDGE, output seal	1	51	25C181	BRACKET, shroud, mount	1
19a	25C162	KIT, washer, support	1	51a	120668	SCREW, flat head (M5X.8)	1
19b	25C163	KIT, bumper, lower	1	53	25C183	KIT, fan	1
19c	25C165	O-ring (2-pack)	1	53a	122347	RING, retaining, external	1
20	25C161	KIT, plug, 3/8 in. npt	1	55	25C184	KIT, cover, shroud	1
24*†	— — —	SCREW, cap, socket head; M8 x 1.25; 30 mm	28	55a	124165	SCREW, shcs, M5–0.8 x 10, ss	1
25	15H432	PLUG, oil drain	1	100	15H392	ADAPTER, rod Xtreme	1
27	25C172	COVER, electrical junction box	1	106	17G768	LABEL, instruction, error code	1
27a	123970	SWITCH, disconnect, 40A	1		17K431	LABEL, instruction, error code, bag (Dutch/German/Swedish, Polish/Russian, Italian/Turkish)	1
33▲	16T764	LABEL, warning	1				
34▲	17J476	LABEL, warning (English/French/Spanish)	1				
	17K430	LABEL, warning, bag (Dutch/German/Swedish, Polish/Russian, Italian/Turkish)	1				
36	16U113	KIT, knob; kit includes replacement parts for one knob	1		Torque to 15–20 ft-lb (20–27 N•m).		
					Torque to 18–23 ft-lb (25–30 N•m).		
38+	16W645	Silicone-Free Synthetic ISO 220 EP Gear Oil; 1 quart (0.95 liter); (not shown)	0		Torque to 175–200 ft-lb (240–280 N•m).		
					Torque to 145–155 ft-lb (195–210 N•m).		
43*†	— — —	WASHER, lock, spring; no. 8	32		Apply serviceable medium thread locker.		

† 15-pack of 24 and 43 (part 25C168).

\* Consult Graco Technical Assistance or your Graco distributor for genuine replacement fasteners. M8 x 30 socket-head cap screws of Class 12.9 steel or better with a minimum yield strength of 1100 MPa (160,000 psi) are acceptable alternatives.

▲ Replacement safety labels, tags, and cards are available at no cost.

Items marked — — — are not available separately.

+ The driver gear box is shipped from the factory pre-filled with oil. Additional oil must be purchased separately.

## Repair Kits and Accessories

Driver Part	Description	Kits	Kit Description
24X960	King Driver	255143	Wall Bracket; see manual 311619.
		16W645	Silicone-Free Synthetic ISO 220 EP Gear Oil; 1 quart (0.95 liter); order 2
		24W120	Position Sensor; see <a href="#">Position Sensor Replacement, page 19.</a>
		25C169	Encoder; see <a href="#">Encoder Replacement, page 16.</a>
		273261	Control board, see <a href="#">Control Board Replacement (273261)</a> , page 14.
	— — —	Software Update Kit (see system manual)	
	Connection kits, to mount an King Driver to an existing pump lower. Kits include tie rods, tie rod nuts, adapter, and coupler.	288207	For Xtreme 145 and 180cc Lower, and 115 cc (L115C5 and L115C6 only)



# Mounting Hole Pattern

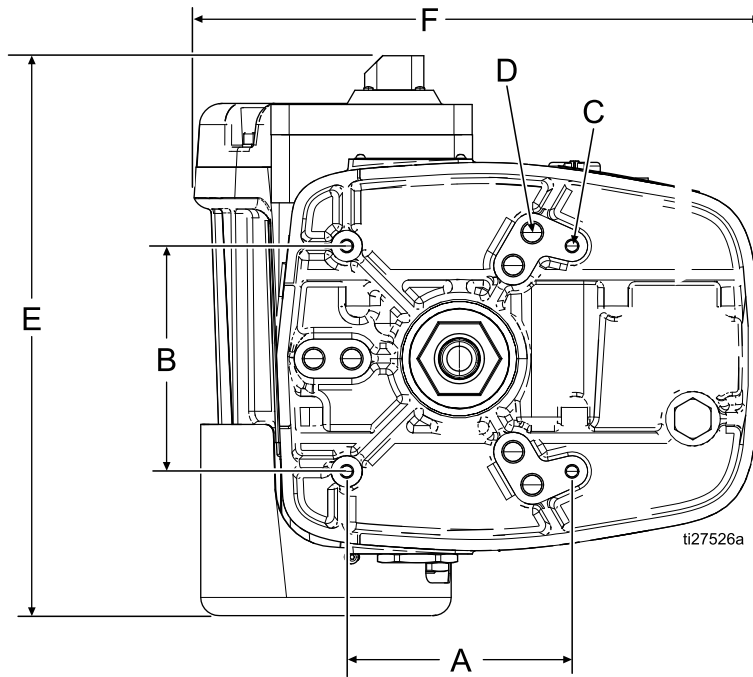

<b>A</b>	6.186 in. (157 mm)
<b>B</b>	6.186 in. (157 mm)
<b>C</b>	Four 3/8-16 Mounting Holes
<b>D</b>	Six 5/8-11 Tie Rod Holes: <ul style="list-style-type: none"> <li>• 8 in. (203 mm) x 120° bolt circle</li> <li>OR</li> <li>• 5.9 in. (150 mm) x 120° bolt circle</li> </ul>
<b>E</b>	15.6 in. (395 mm)
<b>F</b>	15.75 in. (400 mm)

# Wiring Schematic

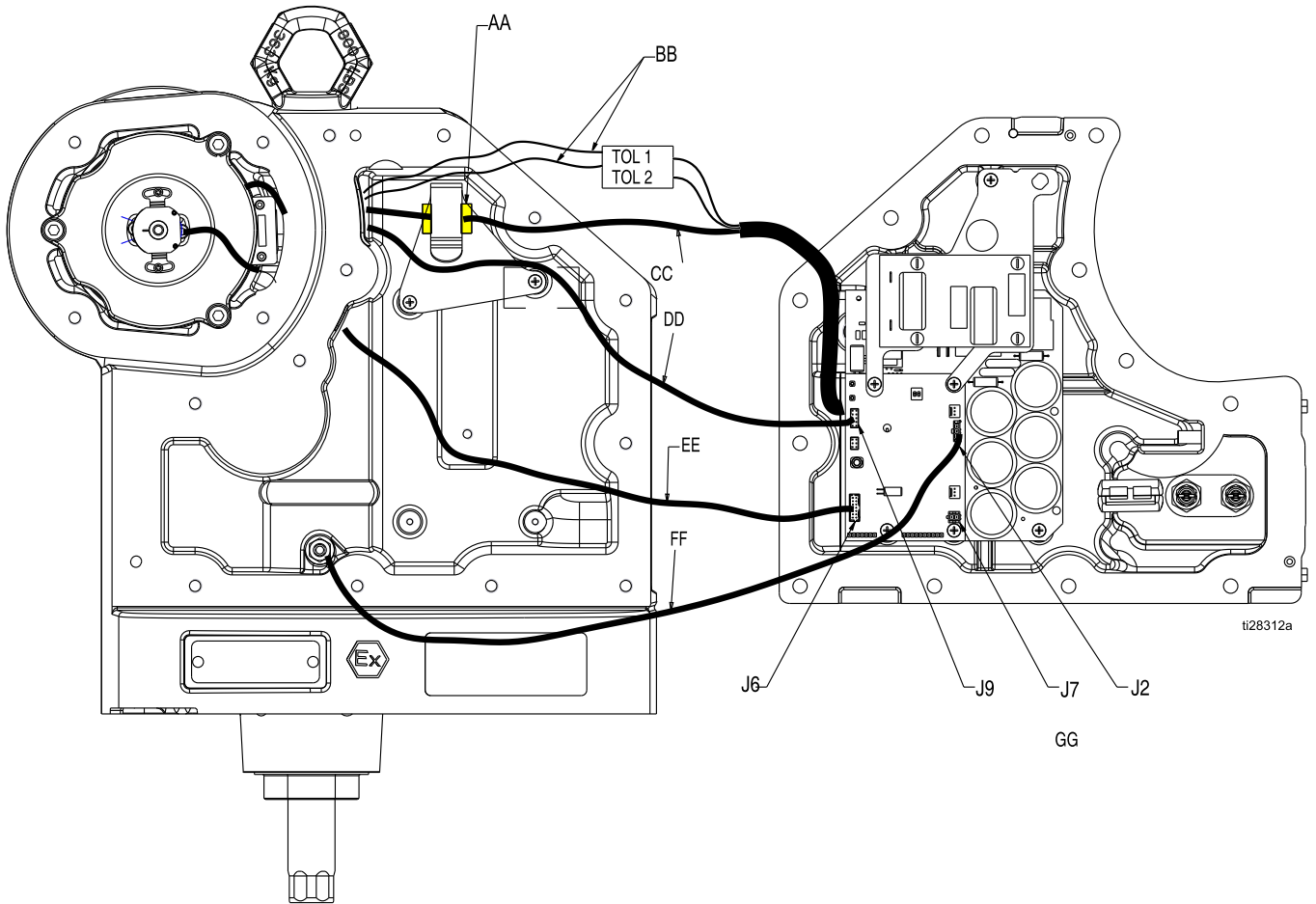

<b>AA</b>	Install Motor Connector Under Clip
<b>BB</b>	Motor Temp Cable
<b>CC</b>	Motor Power Cable
<b>DD</b>	Token Cable
<b>EE</b>	Encoder Cable
<b>FF</b>	Position Sensor and Cable
<b>GG (J7)</b>	Reed Switch (not used)

# Technical Specifications

<b>King Driver Model 24X960</b>		
	<b>U.S.</b>	<b>Metric</b>
Input voltage/power	200–240 VAC single phase, 50/60 Hz, 15 Amp	
	100–120 VAC, single phase, 50/60 Hz, 25 Amp	
Maximum continuous cycle rate	44 cpm	
Maximum force	4,200 lbf	18.7 kN
Power inlet port size	3/4–14 npt(f)	
Ambient temperature range	25° – 120° F	-5° – 50° C
Oil capacity	1.0 – 1.2 quarts	0.9 – 1.1 liters
Oil specification	Graco Part No. 16W645 Silicone-Free Synthetic ISO 220 EP Gear Oil	
Weight	110 lb	50 kg
Minimum recommended generator size	5 kW	
Sound Emissions (per ISO 9614) for Normal Operation (@ 20 cpm)		
Sound Pressure LpA Average	70.2 dBA	
Sound Power LwA Total Power	76.7 dBA	
Sound Emissions (per ISO 9614) for Maximum Speed (@ 44 cpm)		
Sound Pressure LpA Average	77.4 dBA	
Sound Power LwA Total Power	85.1 dBA	

# Graco Extended Warranty

Graco warrants all equipment referenced in this document which is manufactured by Graco and bearing its name to be free from defects in material and workmanship on the date of sale to the original purchaser for use. With the exception of any special, extended, or limited warranty published by Graco, Graco will, for a period of twelve months from the date of sale, repair or replace any part of the equipment determined by Graco to be defective. This warranty applies only when the equipment is installed, operated and maintained in accordance with Graco's written recommendations.

Description	Warranty Period
Gear train, chassis, and electric motor	36 Months
Electronics cover and all other King Driver parts	12 Months

This warranty does not cover, and Graco shall not be liable for general wear and tear, or any malfunction, damage or wear caused by faulty installation, misapplication, abrasion, corrosion, inadequate or improper maintenance, negligence, accident, tampering, or substitution of non-Graco component parts. Nor shall Graco be liable for malfunction, damage or wear caused by the incompatibility of Graco equipment with structures, accessories, equipment or materials not supplied by Graco, or the improper design, manufacture, installation, operation or maintenance of structures, accessories, equipment or materials not supplied by Graco.

This warranty is conditioned upon the prepaid return of the equipment claimed to be defective to an authorized Graco distributor for verification of the claimed defect. If the claimed defect is verified, Graco will repair or replace free of charge any defective parts. The equipment will be returned to the original purchaser transportation prepaid. If inspection of the equipment does not disclose any defect in material or workmanship, repairs will be made at a reasonable charge, which charges may include the costs of parts, labor, and transportation.

**THIS WARRANTY IS EXCLUSIVE, AND IS IN LIEU OF ANY OTHER WARRANTIES, EXPRESS OR IMPLIED, INCLUDING BUT NOT LIMITED TO WARRANTY OF MERCHANTABILITY OR WARRANTY OF FITNESS FOR A PARTICULAR PURPOSE.**

Graco's sole obligation and buyer's sole remedy for any breach of warranty shall be as set forth above. The buyer agrees that no other remedy (including, but not limited to, incidental or consequential damages for lost profits, lost sales, injury to person or property, or any other incidental or consequential loss) shall be available. Any action for breach of warranty hereunder must be brought within the latter of two (2) years of the date of sale, or one (1) year after the warranty period expires.

**GRACO MAKES NO WARRANTY, AND DISCLAIMS ALL IMPLIED WARRANTIES OF MERCHANTABILITY AND FITNESS FOR A PARTICULAR PURPOSE, IN CONNECTION WITH ACCESSORIES, EQUIPMENT, MATERIALS OR COMPONENTS SOLD BUT NOT MANUFACTURED BY GRACO.** These items sold, but not manufactured by Graco (such as electric motors, switches, hose, etc.), are subject to the warranty, if any, of their manufacturer. Graco will provide purchaser with reasonable assistance in making any claim for breach of these warranties.

In no event will Graco be liable for indirect, incidental, special or consequential damages resulting from Graco supplying equipment hereunder, or the furnishing, performance, or use of any products or other goods sold hereto, whether due to a breach of contract, breach of warranty, the negligence of Graco, or otherwise.

## FOR GRACO CANADA CUSTOMERS

The Parties acknowledge that they have required that the present document, as well as all documents, notices and legal proceedings entered into, given or instituted pursuant hereto or relating directly or indirectly hereto, be drawn up in English. Les parties reconnaissent avoir convenu que la rédaction du présente document sera en Anglais, ainsi que tous documents, avis et procédures judiciaires exécutés, donnés ou intentés, à la suite de ou en rapport, directement ou indirectement, avec les procédures concernées.

## Graco Information

For the latest information about Graco products, visit [www.graco.com](http://www.graco.com). For patent information, see [www.graco.com/patents](http://www.graco.com/patents).

**To place an order**, contact your Graco Distributor or call to identify the nearest distributor. **Phone:** 612-623-6921 **or Toll Free:** 1-800-328-0211 **Fax:** 612-378-3505

All written and visual data contained in this document reflects the latest product information available at the time of publication.

Graco reserves the right to make changes at any time without notice. Original Instructions. This manual contains English. **MM 3A8124**

**Graco Headquarters:** Minneapolis **International Offices:** Belgium, China, Japan, Korea  
**GRACO INC. AND SUBSIDIARIES • P.O. BOX 1441 • MINNEAPOLIS MN 55440-1441 • USA**  
**Copyright 2020, Graco Inc. All Graco manufacturing locations are registered to ISO 9001.**

[www.graco.com](http://www.graco.com)

Revision A — October 2020