

Pulse[®] Level WiFi Tank Level Monitor

3A8507D

EN

Measures the distance between the device and the surface of the fluid to determine the volume of fluid within a tank. For use only with Pulse Level. Intended fluids: oil, diesel, waste oil, automatic transmission fluid (ATF), kerosene, anti-freeze, windshield washer solution, waste water, and DEF. For professional use only. Not suitable for tank overflow protection.

Not approved for use in explosive atmospheres or hazardous (classified) locations.

Part No.	Model	Description	Radio Approvals	Model Approvals
25T460	TEK 750	Pulse Level WiFi	FCC, IC, CE, RCM	



Important Safety Instructions

Read all warnings and instructions in this manual and in all related Pulse manuals before using the equipment. Save all instructions.



⚠ WARNING



EQUIPMENT MISUSE HAZARD

Misuse can cause death or serious injury.

- Do not alter or modify equipment. Alterations or modifications may void agency approvals and create safety hazards.
- Make sure all equipment is rated and approved for the environment in which you are using it.
- Use equipment only for its intended purpose. Call your distributor for information.
- Keep children and animals away from work area.
- Comply with all applicable safety regulations.

PERSONAL PROTECTIVE EQUIPMENT

Wear appropriate protective equipment when in the work area to help prevent serious injury, including eye injury, hearing loss, and inhalation of toxic fumes.

This Tank Level Monitor (TLM) contains FCC ID 56T784. This device complies with Part 15 of the FCC Rules. Operation is subject to the following two conditions:

- This device may not cause harmful interference.
- This device must accept any interference received, including interference that may cause undesired operation.

Installation

Set Up

NOTICE	
<ul style="list-style-type: none"> • Do not over tighten TLM into tank bung. Over tightening can cause permanent damage and result in inaccurate readings. • Do not use the TLM with pressurized tanks. Using the TLM in a pressurized tank will damage the TLM. • Do not use thread sealant or adhesive. Many of these products are chemically incompatible with the ABS plastic threads. 	

Connecting to a Network

Summary

Please refer to the instructions in this section, unless indicated otherwise.

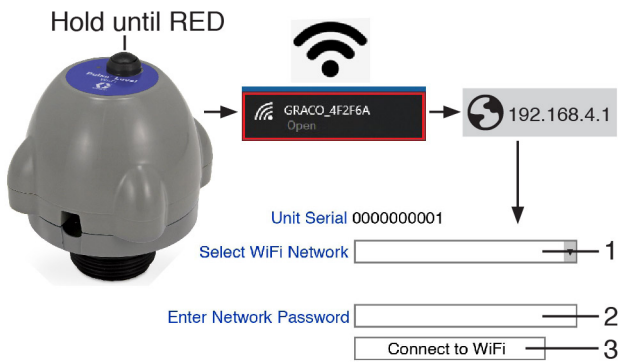

FIG. 1

1. Press and hold the button on the top of the Pulse sensor until the LED light turns red.

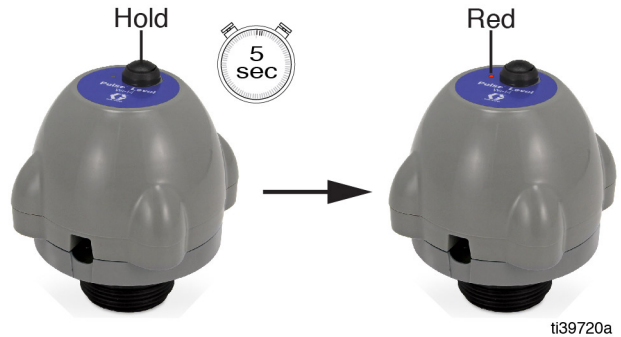

FIG. 2

2. Using a mobile device (e.g. laptop, smart phone, tablet), search for a WiFi network beginning with GRACO and connect.
3. Open a web browser and enter "192.168.4.1" into the address bar.
4. After the WiFi settings page is loaded, select the intended WiFi network from the drop down bar.
5. Enter the selected WiFi network password.
6. Click the Connect to WiFi button.
7. The LED on the Pulse sensor turns green (FIG. 3).



FIG. 3

8. Wait approximately 20 seconds.
9. The sensor flashes red or green several times.
 - Green flashes indicate that a connection to the network has been established.
 - Red flashes indicate that a connection to the network has not been established. The number of red flashes identifies the problem:

Error Flash Patterns (LED)

No. of Flashes	Function	Resolution
1	Unable to find WiFi network	Verify that Connect to WiFi was selected on the browser
2	Unable to connect to WiFi network	Improve WiFi signal strength or enable MAC filtering on the router
3	WiFi password is incorrect	Verify information entered is correct Verify that the WiFi network's security supports WEP, WPA, or WPA2 security
5	Pulse Level is unavailable	Confirm that port 80 is not blocked for your device IP address
6	Invalid response from the Pulse Level	Retry
7	Firmware download failed	Check that the network is up and stable before trying again
8	Low battery	Change batteries
9	Critical failure	Replace the Tank Level Monitor

Register TLM to Tank in Pulse Level Software

Assign a TLM serial number to a tank in Pulse Level.

Navigate to URL: level.gracopulse.com

After creating user, organization, branch and site, navigate to Devices (located in the upper right corner of the screen). Associate the device to your organization by entering the serial number and activation code. When you create a tank for the site, the device will be assignable.

Typical Installation



FIG. 4

Mount Options

Identify a threaded opening on the top of the tank for the sensor. The location should be vertical with a clear path to the contents of the tank. There should be no obstructions that could interfere with the signal.

1. If the hole is not threaded, place the foam gasket (included with kit) over the opening.
2. Place the mounting adapter (included with kit) on top of the foam gasket.
3. Use the two (2) stainless steel self-tapping, counter-sunk screws (included with kit) to attach the adapter to the tank. Do not over tighten.
4. Attach the sensor to the adapter. To form a secure seal, make sure that the sensor is vertical on the tank, that it is secured correctly to the base, and that the threads have not crossed.

NOTE: If the tank does not contain a suitably positioned opening at the top of the tank, reference **Drilling**, page 4.

Installation Examples

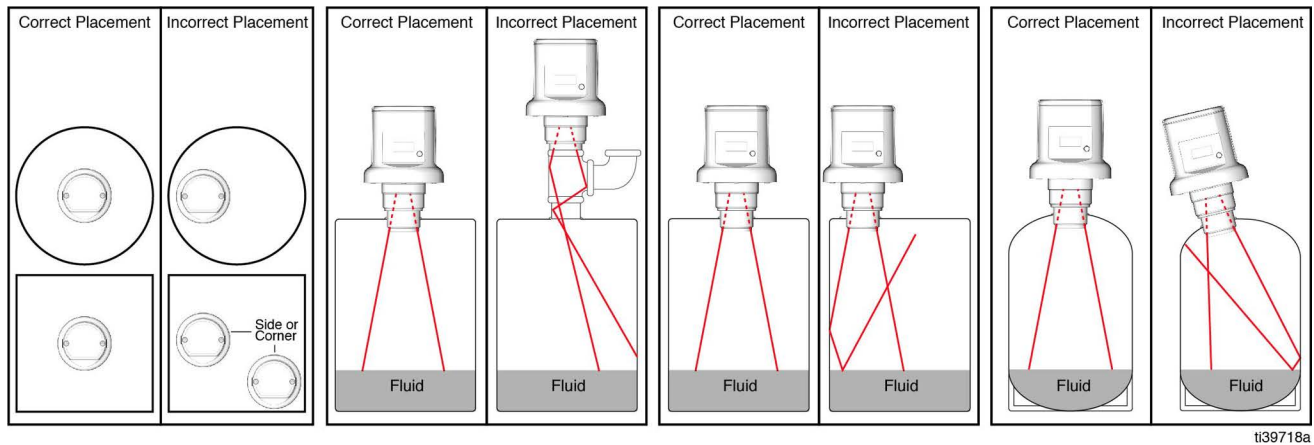

FIG. 5

Drilling

If the tank does not contain a suitable positioned opening at the top of the tank, it will be necessary to manually drill into the top of the tank.

1. Select a flat area on the top of the tank located towards the center (FIG. 5).
2. Drill a 1.5 in. bsp hole at the selected area using a 45.5 mm tapping drill.
3. Continue with **Mount Options**, steps 1 through 4.

Operation

View Data

The TLM can be configured with the Pulse Level (level.gracopulse.com) to take a reading at predefined times.

After configuring the TLM using the TLM Pulse Level, press the button until the green LED is lit, to create a connection between the TLM and the Pulse Level to load the configuration.

NOTE: Frequent measurements result in shorter battery life.

Manual Measurement

To force a measurement:

1. Press and hold the button until the green light illuminates. Release the button.

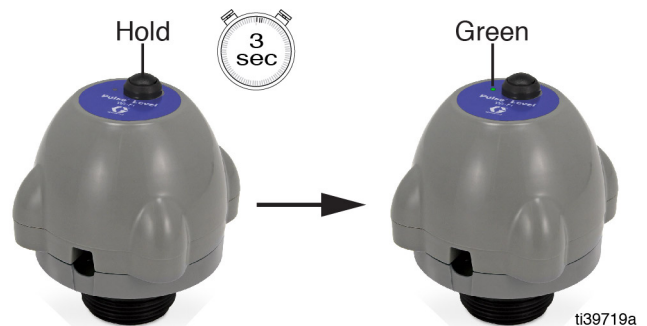

FIG. 6

Recycling and Disposal

End of Product Life

At the end of the product's useful life, dismantle and recycle it in a responsible manner.

- Remove batteries, circuit boards, LCDs (liquid crystal displays), and other electronic components. Recycle according to applicable regulations.

- Do not dispose of batteries or electronic components with household or commercial waste.



- Deliver remaining product to a recycling facility.



Troubleshooting

Problem	Cause	Solution
Monitor is not reporting scheduled readings.	Out of WiFi range. WiFi obstruction.	Ensure that the TLM is not encased in metal, since this would obstruct the signal. Take a manual measurement and review LEDs during the measurement.
	Weak or dead batteries.	Replace batteries. See Replace Batteries , page 6.
	Tank Level Monitor was not associated with profile after scheduled times were entered into software.	Assign TLM serial number to a tank. Press TLM button to take a manual reading.
	Reading is scheduled when pump is operating.	Ensure readings are scheduled during times that the pump is not operating.
LED will not turn on.	Button released too soon.	Hold button down for a longer period of time.
	Weak or dead batteries.	Replace batteries. See Replace Batteries , page 6.

Service

After the TLM has been installed, the only additional maintenance or service necessary is changing the batteries.

Replace Batteries

 WARNING				
				
<p>Fire and Explosion Hazard</p> <p>Sparking can occur when changing batteries. Only replace the batteries in a non-hazardous location away from flammable fluids and fumes.</p>				

NOTICE
<p>After battery placement, press the button to synchronize the TLM internal clock to maintain scheduled TLM readings.</p>

1. Remove the TLM adapter from the tank.
2. Remove the four screws that keep the case together (FIG. 7).

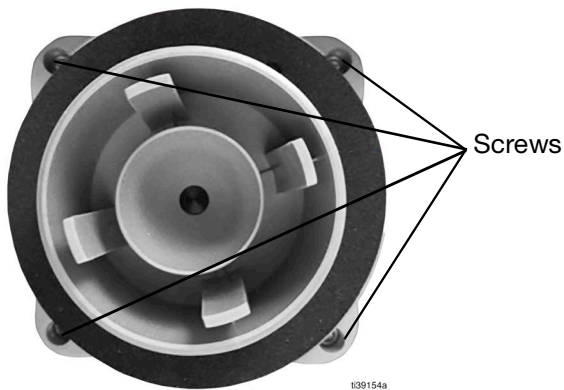

FIG. 7

3. Carefully pull the TLM case halves apart to access the battery (FIG. 8).

NOTE: The TLM case halves are tightly connected. Use caution when opening the device to prevent unnecessary damage.



FIG. 8

4. Replace the 3.6V C-size battery. See **Technical Specifications**, page 8, for battery information. Install the battery as shown in FIG. 9, with the positive end on the right. This is the clip that has shrink tubing on it.
5. To maintain the IP rating, make sure that the gasket is properly installed (FIG. 9).



FIG. 9

6. Reconnect the two halves and replace the four screws.

Dimension - Tank Specifications

Vertical Tank:

- Maximum Volume - 999,999 gallons or liters.
- Tank walls must be uniformly vertical from empty level to full.

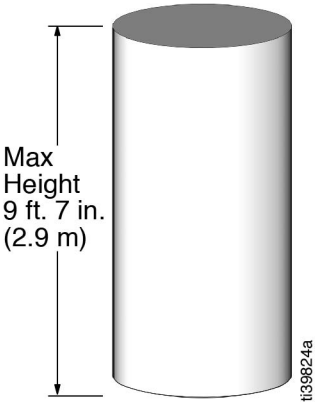

FIG. 10

Obround Tank:

- Maximum volume = 999,999 gallons or liters.
- Tank end walls must be flat; they cannot be any other shape, including belled.

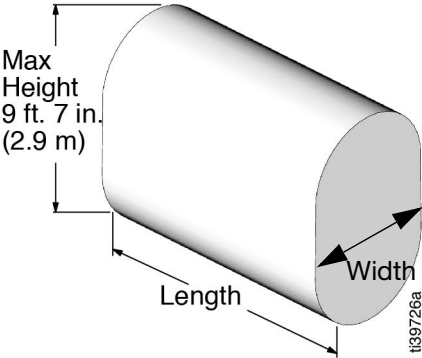

FIG. 12

Cylindrical Tank:

- Maximum volume = 999,999 gallons or liters.
- Tank end walls must be flat; they cannot be any other shape, including belled.

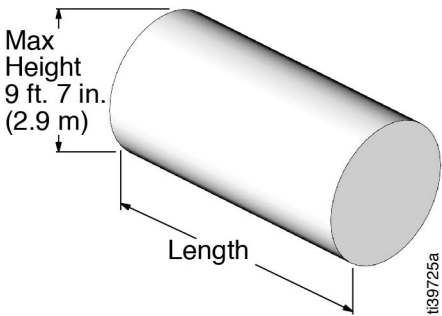

FIG. 11

Non-Standard Tanks:

- Maximum volume = 999,999 gallons or liters.
- Define strapping table in Pulse Level Software.
- Up to 100 strapping table points to correlate tank fluid height to volume.

Technical Specifications

Tank Level Monitor (TLM)		
	US	Metric
Compatible Fluids	oil, kerosene, diesel, lubricants, additives, DEF/AdBlue®, coolants, water, waste oil, waste water, automatic transmission fluid (AFT), anti-freeze, and windshield washer solution	
Ultrasonic Tank Depth Measurement range	5.0 in. to 9 ft. 7 in.	12 cm (minimum) to 300 cm
Fluid Level Measurement Accuracy	+/- 1.0 in.	+/- 2.0 cm
Mounting	1.25 in., 1.5 in, and 2.0 in. threaded npt connector	
Clearance: Height above tank for TLM	7.5 in.	19.1 cm
Weight	0.5 lb.	226.8 g
RF Frequency Band	2.412 GHz - 2.462 GHz	
Maximum RF Transmit Power	18 dBm	
Operating Temperature Range	0°F to 122°F	-17.8°C to 50°C
Storage Temperature Range	0°F to 122°F	-17.8°C to 50°C
Batteries	Li-SOCl ₂ Size R14, 3.6V C-cell	
Battery Life	7.5 years* from activation	
Enclosure (Ingress Protection)	IP67	
Tanks		
Maximum Volume	999,999 gallons	999,999 liters
Maximum Height	9 ft. 7 in.	300 cm
Altitude	<6,000 ft.	< 2 km
<p>* The battery life is based upon four (4) measurements per day and one (1) WiFi connection per day from a location where the WiFi coverage does not require retries, and a normal distribution over the operating temperature range centered at +25°C (77°F).</p>		
<p>All trademarks or registered trademarks are the property of their respective owners.</p>		

California Proposition 65

CALIFORNIA RESIDENTS

 **WARNING:** Cancer and reproductive harm – www.P65warnings.ca.gov.

Graco Extended Warranty

Graco warrants all equipment manufactured by Graco and bearing its name to be free from defects in material and workmanship on the date of sale to the original purchaser for use. With the exception of any special, extended, or limited warranty published by Graco, Graco will, for a period of twenty four months from the date of sale, repair or replace any part of the equipment determined by Graco to be defective. This warranty applies only when the equipment is installed, operated and maintained in accordance with Graco's written recommendations.

This warranty does not cover, and Graco shall not be liable for general wear and tear, or any malfunction, damage or wear caused by faulty installation, misapplication, abrasion, corrosion, inadequate or improper maintenance, negligence, accident, tampering, or substitution of non-Graco component parts. Nor shall Graco be liable for malfunction, damage or wear caused by the incompatibility of Graco equipment with structures, accessories, equipment or materials not supplied by Graco, or the improper design, manufacture, installation, operation or maintenance of structures, accessories, equipment or materials not supplied by Graco.

This warranty is conditioned upon the prepaid return of the equipment claimed to be defective to an authorized Graco distributor for verification of the claimed defect. If the claimed defect is verified, Graco will repair or replace free of charge any defective parts. The equipment will be returned to the original purchaser transportation prepaid. If inspection of the equipment does not disclose any defect in material or workmanship, repairs will be made at a reasonable charge, which charges may include the costs of parts, labor, and transportation.

THIS WARRANTY IS EXCLUSIVE, AND IS IN LIEU OF ANY OTHER WARRANTIES, EXPRESS OR IMPLIED, INCLUDING BUT NOT LIMITED TO WARRANTY OF MERCHANTABILITY OR WARRANTY OF FITNESS FOR A PARTICULAR PURPOSE.

Graco's sole obligation and buyer's sole remedy for any breach of warranty shall be as set forth above. The buyer agrees that no other remedy (including, but not limited to, incidental or consequential damages for lost profits, lost sales, injury to person or property, or any other incidental or consequential loss) shall be available. Any action for breach of warranty must be brought within two (2) years of the date of sale Graco makes no warranty, and disclaims all implied warranties of merchantability and fitness for a particular purpose in connection with accessories, equipment, materials or components sold but not manufactured by Graco. These items sold, but not manufactured by Graco (such as electric motors, switches, hose, etc.), are subject to the warranty, if any, of their manufacturer. Graco will provide purchaser with reasonable assistance in making any claim for breach of these warranties.

In no event will Graco be liable for indirect, incidental, special or consequential damages resulting from Graco supplying equipment hereunder, or the furnishing, performance, or use of any products or other goods sold hereto, whether due to a breach of contract, breach of warranty, the negligence of Graco, or otherwise.

FOR GRACO CANADA CUSTOMERS

The parties acknowledge that they have required that the present document, as well as all documents, notices and legal proceedings entered into, given or instituted pursuant hereto or relating directly or indirectly hereto, be drawn up in English. Les parties reconnaissent avoir convenu que la rédaction du présente document sera en Anglais, ainsi que tous documents, avis et procédures judiciaires exécutés, donnés ou intentés à la suite de ou en rapport, directement ou indirectement, avec les procédures concernées.

Graco Information

For the latest information about Graco products, visit www.graco.com.

For patent information, see www.graco.com/patents.

TO PLACE AN ORDER, contact your Graco distributor or call to identify the nearest distributor.

Phone: 612-623-6928 or **Toll Free:** 1-800-533-9655, **Fax:** 612-378-3590

All written and visual data contained in this document reflects the latest product information available at the time of publication. Graco reserves the right to make changes at any time without notice.

Original instructions. This manual contains English. MM 3A8507

Graco Headquarters: Minneapolis

International Offices: Belgium, China, Japan, Korea

GRACO INC. AND SUBSIDIARIES • P.O. BOX 1441 • MINNEAPOLIS MN 55440-1441 • USA
Copyright 2021, Graco Inc. All Graco manufacturing locations are registered to ISO 9001.

www.graco.com
Revision D, November 2022