

# IniFlex™

## Modular Proportioner Components

3A8637C

EN

*Robot arm mountable paint application modules to support ProMix 1K and 2K color/catalyst change, fluid metering, and flow control on with industrial paint applications. For professional use only.*

### IniFlex Components

300 psi (2 MPa, 20 bar) Maximum Fluid Working Pressure

See page 3 for model information.



#### Important Safety Instructions

Read all warnings and instructions in this manual and in the meter, regulator, valve, and quick connect manuals before using the equipment. Save all instructions.

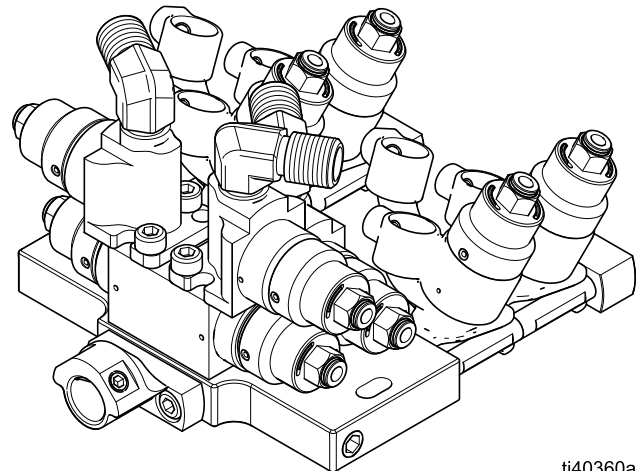

ti40360a

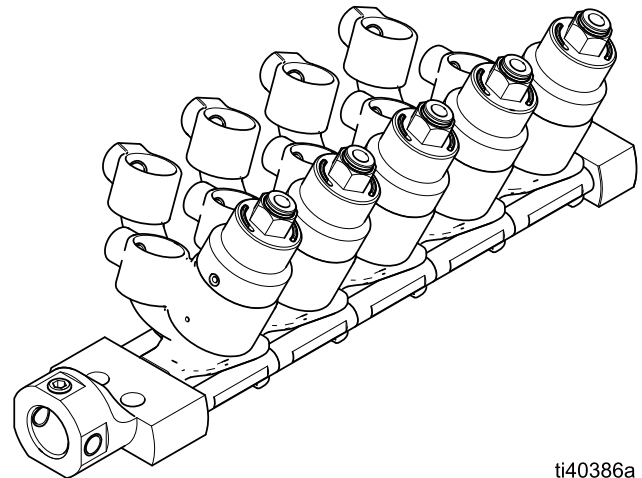

ti40386a

# Contents

<b>Related Manuals</b> . . . . .	<b>2</b>	Assemble a Color Change Stack . . . . .	16
<b>Model Number Matrices</b> . . . . .	<b>3</b>	Insert Additional Valves in a Color Change Stack . . . . .	17
Pre-Configured Color Change Stack Model Numbers . . . . .	3	Connect Air and Fluid Tubes . . . . .	17
Dose/Mix Manifold Model Numbers . . . . .	4	Switch Block . . . . .	18
Switch Block Model Numbers . . . . .	5	Attach a Color Change Stack . . . . .	18
Auto Gun Model Numbers . . . . .	6	Attach a Dump Manifold . . . . .	18
Meter Model Numbers . . . . .	7	Attach a Gun Flush Manifold . . . . .	18
Quick Socket Fitting Model Numbers . . . . .	8	Attach a Dump Plug . . . . .	19
Regulator Model Numbers . . . . .	9	Attach a Purge Plug . . . . .	19
Available Restriction Fitting Kits . . . . .	10	Connect Air and Fluid Tubes . . . . .	19
Mix Manifold Restrictor Fittings . . . . .	10	Auto Gun . . . . .	20
26D220 Dump Valve . . . . .	11	Additional Components . . . . .	20
2KS Robot Arm with Mounted IniFlex Components . . . . .	11	Regulator . . . . .	20
<b>Warnings</b> . . . . .	<b>12</b>	Meter . . . . .	20
<b>Important Isocyanate (ISO) Information</b> . . . . .	<b>14</b>	Typical Configurations . . . . .	22
Isocyanate Conditions . . . . .	14	<b>Parts</b> . . . . .	<b>24</b>
Keep Components A and B Separate . . . . .	14	Pre-Configured Color Change Stack . . . . .	24
Moisture Sensitivity of Isocyanates . . . . .	14	Switch Block . . . . .	26
Changing Materials . . . . .	15	Accessories . . . . .	28
<b>Installation</b> . . . . .	<b>16</b>	<b>Assembly Mounting Holes</b> . . . . .	<b>30</b>
Grounding . . . . .	16	<b>California Proposition 65</b> . . . . .	<b>32</b>
Flush Before Using Equipment . . . . .	16	<b>Technical Specifications</b> . . . . .	<b>33</b>
Color Change Stack . . . . .	16	<b>Graco Standard Warranty</b> . . . . .	<b>34</b>

## Related Manuals

Manual in English	Description
308778	Volumetric Fluid Flow Meter, Instructions-Parts
3A0427	Low Flow Fluid Regulator, Instructions-Parts
312782	Air Actuated Dispense Valve, Instructions-Parts
3A8638	Quick Socket Fitting Kit, Instructions
312781	Fluid Mix Manifold, Instructions-Parts
312778	ProMix <sup>®</sup> 2KS, Installation
312779	ProMix <sup>®</sup> 2KS, Operation
312780	ProMix <sup>®</sup> 2KS, Repair-Parts

# Model Number Matrices

## Pre-Configured Color Change Stack Model Numbers

(See page 24 for parts list.)

**NOTE:** A color change stack can be all circulation valves, all non-circulation valves, or a combination of the two. In a combination stack, the circulation valves are assembled on the outlet end followed by the non-circulation valves. When circulation valves begin the stack, no more than three non-circulation valves are available as pre-configured color change stack models. Pre-configured stacks can be expanded by ordering individual stack modules.

Features					
IniFlex Base Number	Circulation Valves*		Non-Circulation Valves* (Only 3 allowed if Preceded by a Circulation Valve)		Outlet Fitting Type
FXCC	(2 digit)		(2 digit)		(1 digit)
	# of Valves	18	# of Valves	18	IniFlex Plug C
	# of Valves	17	# of Valves	17	Quick Socket S
	# of Valves	16	# of Valves	16	
	# of Valves	15	# of Valves	15	
	# of Valves	14	# of Valves	14	
	# of Valves	13	# of Valves	13	
	# of Valves	12	# of Valves	12	
	# of Valves	11	# of Valves	11	
	# of Valves	10	# of Valves	10	
	# of Valves	09	# of Valves	09	
	# of Valves	08	# of Valves	08	
	# of Valves	07	# of Valves	07	
	# of Valves	06	# of Valves	06	
	# of Valves	05	# of Valves	05	
	# of Valves	04	# of Valves	04	
	# of Valves	03	# of Valves	03	
	# of Valves	02	# of Valves	02	
	# of Valves	01	# of Valves	01	
	# of Valves	00			

\* Color change valves are available in circulation and single-line supply options. Circulation valves allow for paint to be supplied to, and returned from, the supply module, allowing a continuous fluid circulation of paint to prevent settling of pigments and color variation to the color selection valve.

The IniFlex Plug (FXCCxxxxC) is a disposable shipping plug. Its removal allows connection with other IniFlex components.

The Quick Socket (FXCCxxxxS) outlet allows connection with Quick Socket fittings, such as when connecting directly to your proportioner system.

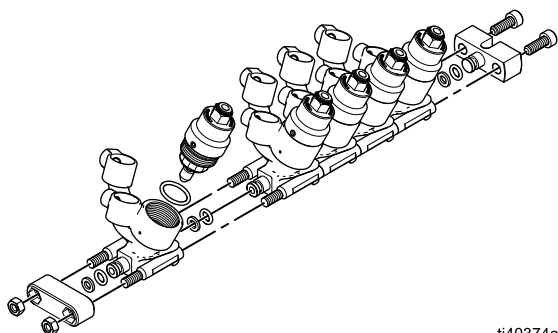
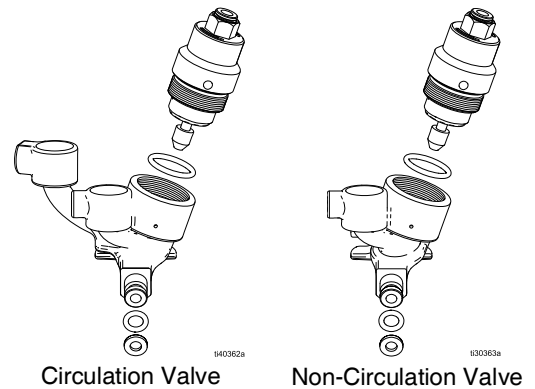

FXCC0401C

ti40374a

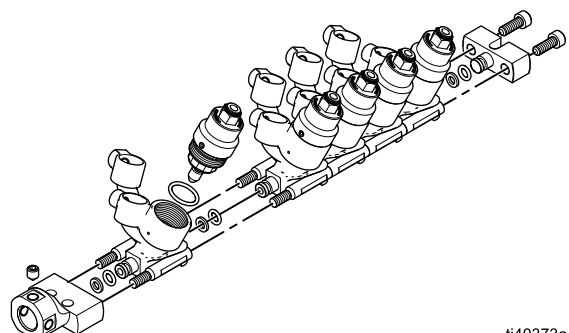

FXCC0401S

ti40373a

# Dose/Mix Manifold Model Numbers

(See manual 312781 for operation and parts.)

Features				
IniFlex Base Number	A Side Dump		B Side Dump	
FXMM	(1 digit)		(1 digit)	
	None	X	None	X
	A Side Dump	A	B Side Dump	B

### Fluid Path Key

- A "A" Side Dispense Valve
- B "A" Side Purge Valve\*
- C "A" Side Dump Valve\*
- D "B" Side Dispense Valve
- E "B" Side Purge Valve\*
- F "B" Side Dump Valve\*

\* All Dump and Purge valve fluid connections are 1/4 in. npt(m).

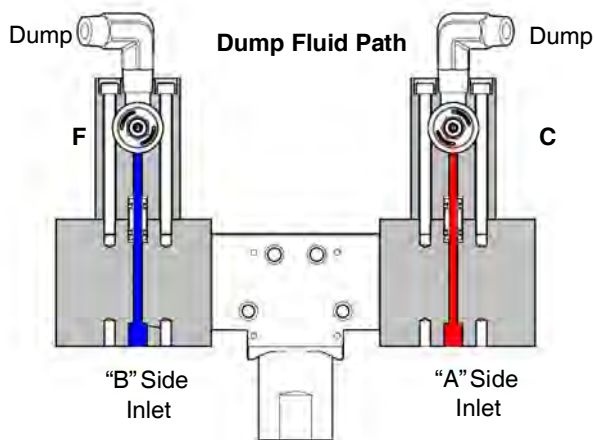
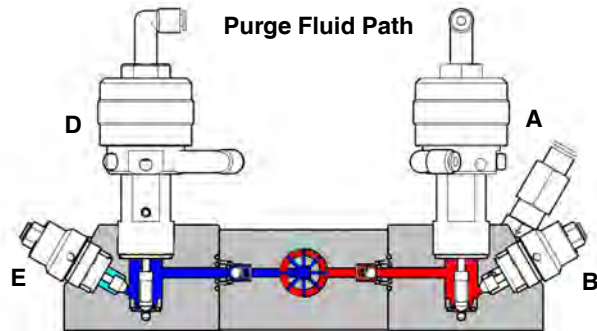
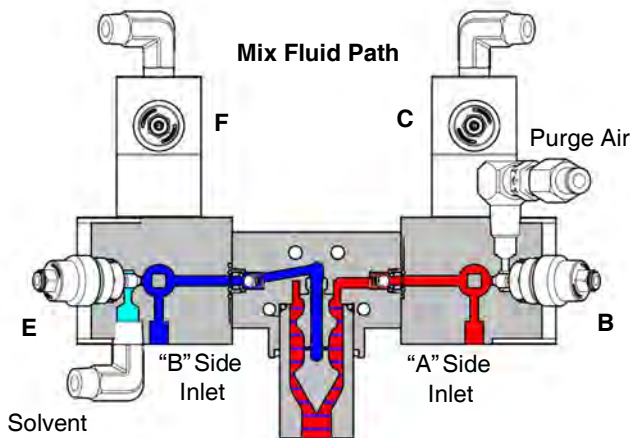
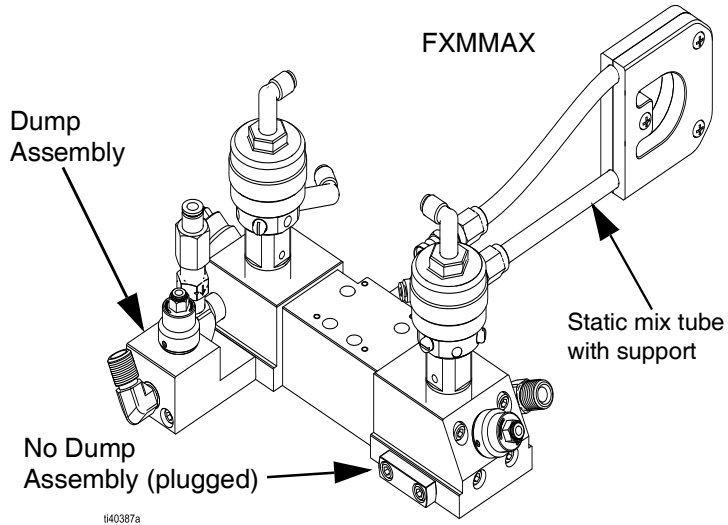

All models ship with a 10 cc integrator. The manifold is compatible with all integrators. Optional sizes include 25, 50, and 100 cc. See manual 312781 for optional Integrator Kits.

See **Technical Specifications**, page 33, for component weights.

**NOTE:** The static mix elements can be installed in the inlet, outlet, or one in each end of the mixer tube. The mixer element locations are determined by the integrator size and length. Select the mixer element locations to allow for the shortest mixer tube length. Cut the mixer tube at a length that allows the mix elements to be inserted into straight sections of mix tube. Do not bend mixer elements, or force them into arcing sections of the mixer tube. Allow a few inches of distance from the mixer elements and the mix tube bend radius support blocks. Assemble the mixer tube, mixers, and fittings to the manifold, and then add the bend radius support blocks. This installation procedure will eliminate the need to try cutting each tubing end to the exact right length for the fitting and connection locations.

## Switch Block Model Numbers

The fluid supply switch block allows queuing up colors, for faster color changes, and for the use of different paint chemistries and flush materials to be supplied to a single-mix manifold. Additional colors can be added where the length of the color stack is more limited than the width. See **Switch Block**, page 26, for replacement parts, and **Technical Specifications**, page 33, for component weights.

Features						
IniFlex Base Number	Gun Flush		Side 1 Dump		Side 2 Dump	
FXSB	(1 digit)		(1 digit)		(1 digit)	
	None	X	None	X	None	X
	Gun Flush	F	Side 1 Dump	1	Side 2 Dump	2

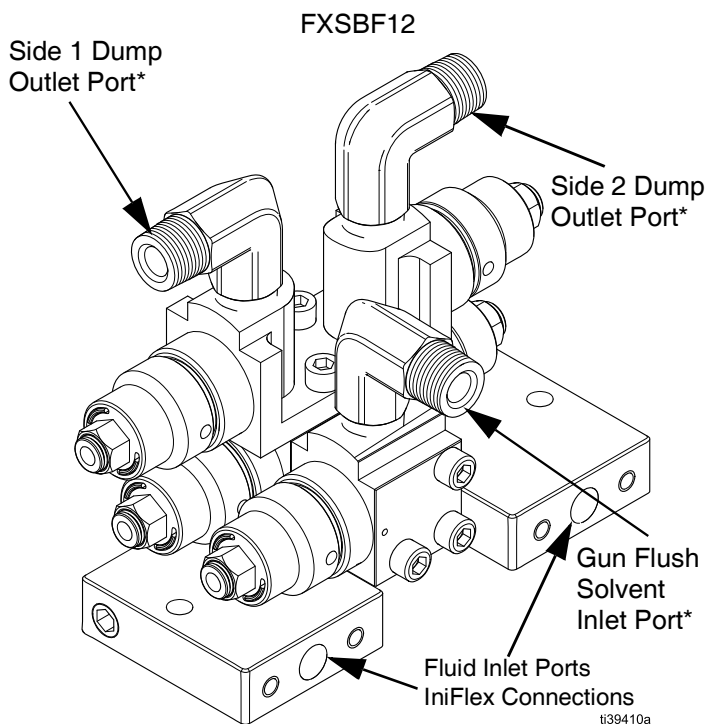

\* All Dump and Flush ports are 1/4 in. npt(m).

### Fluid Path Key

- A Dispense Valve 1
- B Dump Valve 1
- C Dispense Valve 2
- D Dump Valve 2
- E Gun Flush Valve

All Dump and Flush Fluid Connections are 1/4 in. npt(m).

### Color Stack Input Flow Path

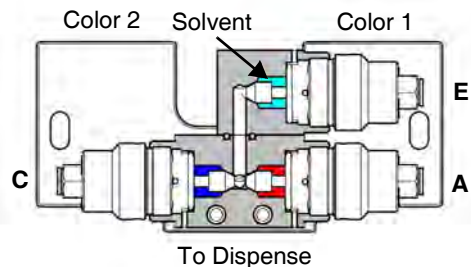

### Purge Valve Flow Path

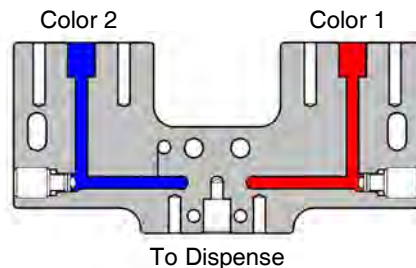

### Dump Valve Flow Path

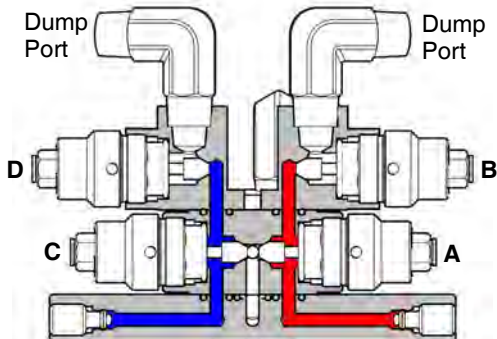

## Auto Gun Model Numbers

(See page 26 for replacement parts.)

Features	
IniFlex Number	Description
FXAG04	Arrangement with four non-circulation valves.
FXAG22	Arrangement with two circulation and two non-circulation valves.
FXAG40	Arrangement with four circulation valves.

All Dump and Flush Fluid Connections are 1/4 in. npt(m).

**NOTE:** This assembly comes pre-configured with two valves per side, for a total of only four valves; four circulation valves, four non-circulation valves, or two of each.

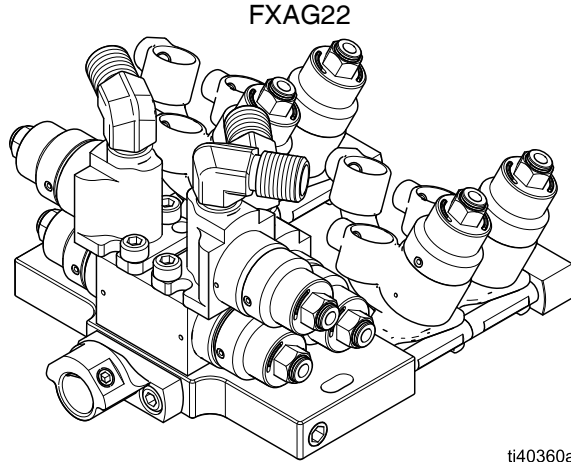

ti40360a

# Meter Model Numbers

(See manual 308778 for operation and parts.)

Features				
IniFlex Base Number	Meter Cable		Connection	
FX250	(1 digit)		(1 digit)	
	None	X	None	X
	50 ft	S	FXCC IniFlex Link	T
			IniFlex Link (x2)	K
			Quick Socket & IniFlex Link	S

**NOTE:** See **Accessories**, page 28, for additional information on fluid connections.

The T connection is used primarily to connect with a color change stack (FXCC) outlet port.

The K connection fits any IniFlex component.

The S connection is a Quick Socket fitting that connects IniFlex components to non-IniFlex components.

**NOTE:** All FX250 meter family products use a .119 cc/pulse nominal K-factor.

See **Technical Specifications**, page 33, for component weights.

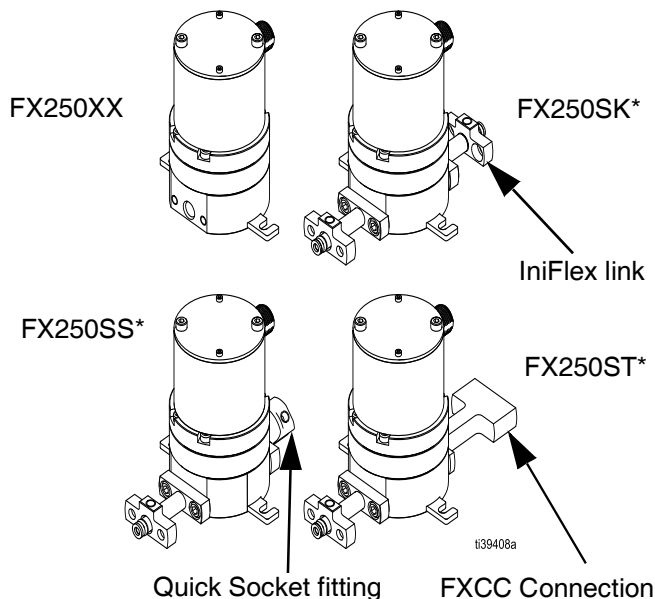

\* Cable 17C888 (50 ft.) included, not shown

Optional Meter Cables	
P/N	Length
17C909	1.6 ft.
17C910	3.5 ft.
17C743	5 ft.
17C887	6 ft.
17C888	50 ft.
17C889	150 ft.

All cable options include stripped ends for terminal block connection to 2KE and 2KS input terminals.

## Quick Socket Fitting Model Numbers

(See **Accessories**, page 28, for additional connection options; see manual 3A8638 for installation and parts.)

Features				
IniFlex Base Number	Fitting Style		Pack Quantity	
FXF	(1 digit)		(2 digits)	
	1/4" NPT	P	Qty 1	01
	1/4" BSPP	B	Qty 10	10
	Nylon Tube*	N	Qty 20	20
	FEP Tube**	F	Qty 50	50

Color Stacks	Connection Type	Qty
Circulation Valves	Tubing, FEP or Nylon, threaded npt/bspp	2/Valve
Non-circulation Valves		1/Valve
CC Stack only w/QS Outlet		1/CC Stack

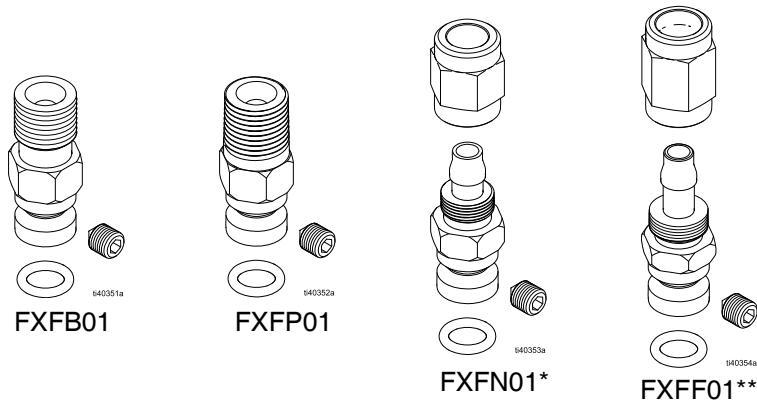

\* Nylon tubing, part no. 061132, 1/4" ID, 225 psi working pressure  
 \*\* FEP tubing, part no. 597350, 1/4" ID, 190 psi working pressure

**Table 1: Quick Socket Fitting Quantities Required for Color Stacks and Mix Manifolds**

Color Stacks	Connection Type (may vary)	Quantity	Total Quantity
Circulation Valves	Tubing, FEP or Nylon, Threaded npt/bspp	2/Valve	
Non-Circulation Valves		1/ Valve	
Color Change Stack only, w/Quick Socket Outlet		1/CC Stack	
<b>Mix Manifold / Mixer or Flow Control</b>		<b>1/Assembly</b>	
Outlet Port to Applicator		1 required	
Connection to Applicator		1 required	



## Regulator Model Numbers

IniFlex pneumatic-controlled fluid regulators can be added for precise fluid pressure control. They can also be integrated into ProMix systems for closed-loop flow control. (See manual 3A0427 for operation and parts.)

Features				
IniFlex Base Number	Regulator Options	Outlet Regulator Accessories		Inlet Regulator Accessories
FXRG	(1 digit)	(1 digit)		(1 digit)
	Ratio 1:1	1	None (Quick Socket outlet is standard)	X Blank (IniFlex inlet is standard)
	Ratio 1:2	2	Transducer Fitting*	T Mix Manifold Fitting**
	Ratio 1:3	3		M

\* The Transducer Fitting allows for a pressure transducer installation compatible with ProMix 2KS and 1KE Plus flow control systems. See **Available Restriction Fitting Kits**, page 10.

\*\* The Mix Manifold inlet fitting allows for connection to the IniFlex FXMM static mixer. It is also compatible with any Quick Socket FXF fitting. See **Mix Manifold Restrictor Fittings**, page 10.

See **Technical Specifications**, page 33, for component weights.

**NOTE:** An Air Pressure Transducer and a Fluid Pressure Sensor are included in 2KS Flow Control Kit (24H989).

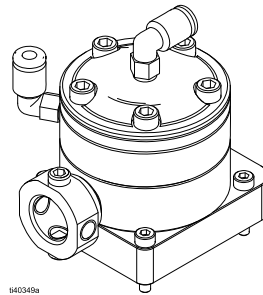

FXRG1X

140349a

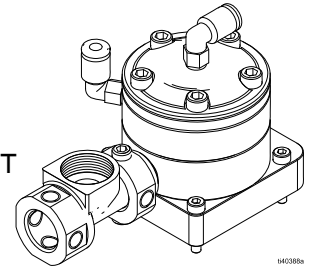

FXRG1T

140388a

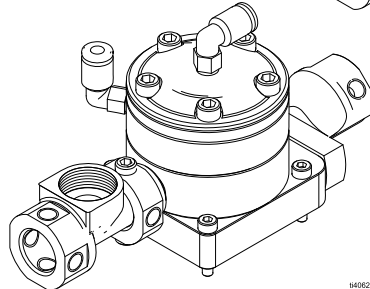

FXRG1TM

140624a

### Available Restriction Fitting Kits

Part No.	Description
FXF010	0.010 in. Quick Socket Fitting Kit
FXF014	0.014 in. Quick Socket Fitting Kit
FXF020	0.020 in. Quick Socket Fitting Kit
FXF029	0.029 in. Quick Socket Fitting Kit
FXF040	0.040 in. Quick Socket Fitting Kit

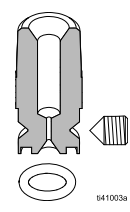

### Mix Manifold Restrictor Fittings

For use downstream of the fluid regulator with FXMM Dose/Mix Manifolds to create additional back pressure for flow control applications. For optimal flow control application performance, it is recommended that at least 8 psi (0.5 bar) back pressure be present at the fluid regulator outlet during target flow rates. Use an alternate downstream fluid line size or a restriction fitting to create additional back pressure.

**Pressure Drop Through FXF Restrictor Fittings (32 Centipoise Fluid)**

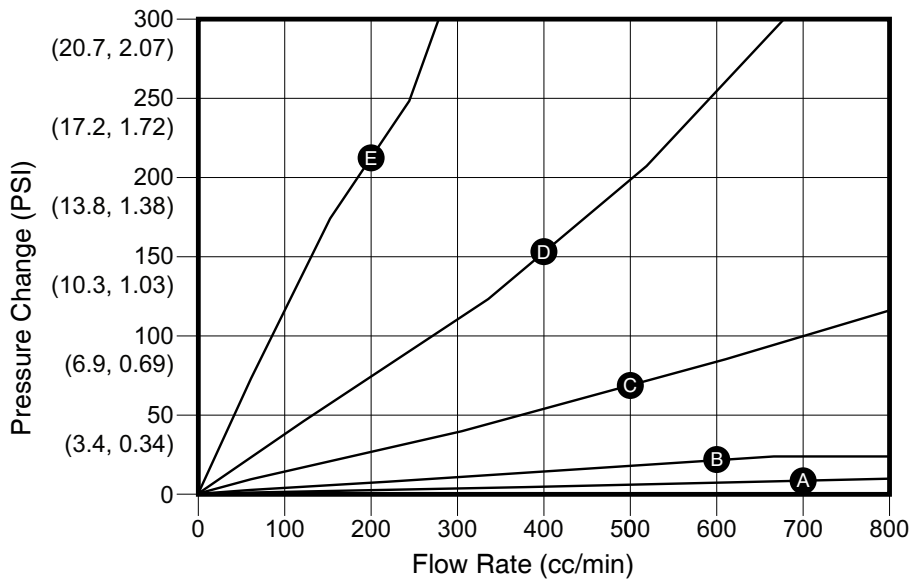

- A - FXF040
- B - FXF029
- C - FXF020
- D - FXF014
- E - FXF010

**Pressure Drop Through FXF Restrictor Fittings (940 Centipoise Fluid)**

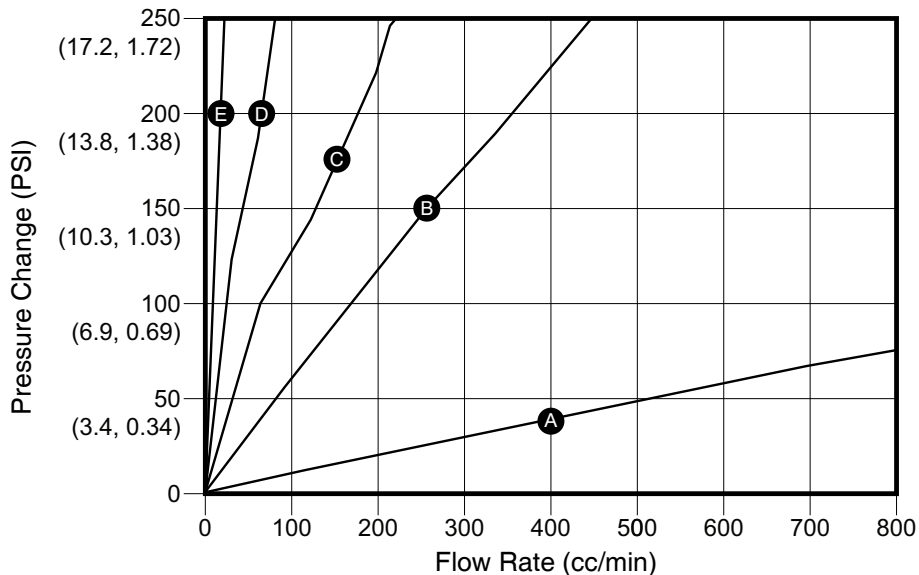

**FIG. 1: Pressure Drops Through FXF Restrictor Fittings**

## 26D220 Dump Valve

Fluid inlet and outlet ports are 1/4 in. npt(f), and 303 SST wetted parts.

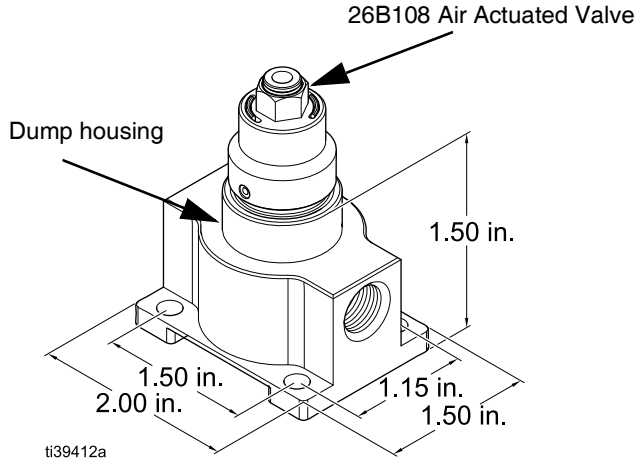

## 2KS Robot Arm with Mounted IniFlex Components

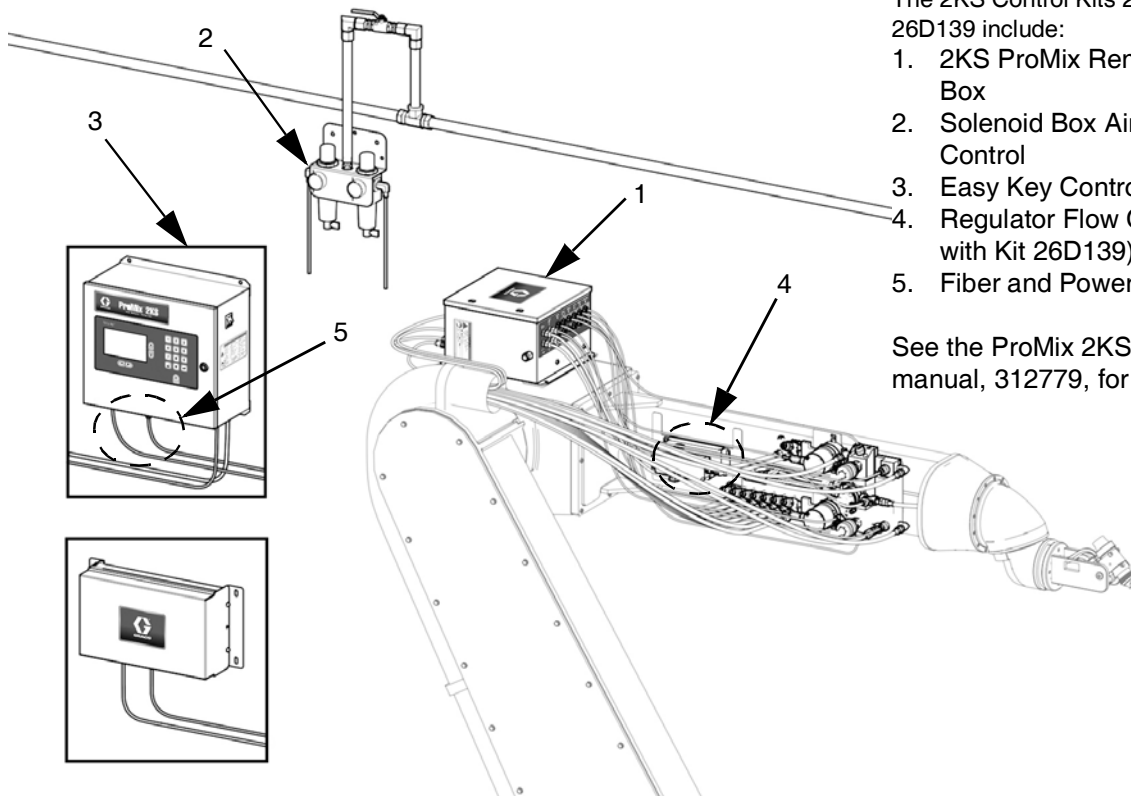









The 2KS Control Kits 26D138 and 26D139 include:

1. 2KS ProMix Remote Control Box
2. Solenoid Box Air Supply Control
3. Easy Key Control Box
4. Regulator Flow Control (only with Kit 26D139)
5. Fiber and Power Cables, 50 ft.

See the ProMix 2KS Operation manual, 312779, for details.

# Warnings

The following warnings are for the setup, use, grounding, maintenance, and repair of this equipment. The exclamation point symbol alerts you to a general warning and the hazard symbols refer to procedure-specific risks. When these symbols appear in the body of this manual or on warning labels, refer back to these Warnings. Product-specific hazard symbols and warnings not covered in this section may appear throughout the body of this manual where applicable.

 <h2 style="margin: 0;">WARNING</h2>	
   	<p><b>FIRE AND EXPLOSION HAZARD</b></p> <p>Flammable fumes, such as solvent and paint fumes, in <b>work area</b> can ignite or explode. Paint or solvent flowing through the equipment can cause static sparking. To help prevent fire and explosion:</p> <ul style="list-style-type: none"> <li>• Use equipment only in well-ventilated area.</li> <li>• Eliminate all ignition sources; such as pilot lights, cigarettes, portable electric lamps, and plastic drop cloths (potential static sparking).</li> <li>• Ground all equipment in the work area. See <b>Grounding</b> instructions.</li> <li>• Never spray or flush solvent at high pressure.</li> <li>• Keep work area free of debris, including solvent, rags and gasoline.</li> <li>• Do not plug or unplug power cords, or turn power or light switches on or off when flammable fumes are present.</li> <li>• Use only grounded hoses.</li> <li>• Hold gun firmly to side of grounded pail when triggering into pail. Do not use pail liners unless they are anti-static or conductive.</li> <li>• <b>Stop operation immediately</b> if static sparking occurs or you feel a shock. Do not use equipment until you identify and correct the problem.</li> <li>• Keep a working fire extinguisher in the work area.</li> </ul>
  	<p><b>PRESSURIZED EQUIPMENT HAZARD</b></p> <p>Fluid from the equipment, leaks, or ruptured components can splash in the eyes or on skin and cause serious injury.</p> <ul style="list-style-type: none"> <li>• Follow the <b>Pressure Relief Procedure</b> in all equipment manuals when you stop spraying/dispensing and before cleaning, checking, or servicing equipment.</li> <li>• Tighten all fluid connections before operating the equipment.</li> <li>• Check hoses, tubes, and couplings daily. Replace worn or damaged parts immediately.</li> </ul>

# ! WARNING



## EQUIPMENT MISUSE HAZARD

Misuse can cause death or serious injury.



- Do not operate the unit when fatigued or under the influence of drugs or alcohol.
- Do not exceed the maximum working pressure or temperature rating of the lowest rated system component. See **Technical Specifications** in all equipment manuals.
- Use fluids and solvents that are compatible with equipment wetted parts. See **Technical Specifications** in all equipment manuals. Read fluid and solvent manufacturer's warnings. For complete information about your material, request Safety Data Sheets (SDSs) from distributor or retailer.
- Do not leave the work area while equipment is energized or under pressure.
- Turn off all equipment and follow the **Pressure Relief Procedure** in all equipment manuals when equipment is not in use.
- Check equipment daily. Repair or replace worn or damaged parts immediately with genuine manufacturer's replacement parts only.
- Do not alter or modify equipment. Alterations or modifications may void agency approvals and create safety hazards.
- Make sure all equipment is rated and approved for the environment in which you are using it.
- Use equipment only for its intended purpose. Call your distributor for information.
- Route hoses and cables away from traffic areas, sharp edges, moving parts, and hot surfaces.
- Do not kink or over bend hoses or use hoses to pull equipment.
- Keep children and animals away from work area.
- Comply with all applicable safety regulations.



## TOXIC FLUID OR FUMES HAZARD

Toxic fluids or fumes can cause serious injury or death if splashed in the eyes or on skin, inhaled or swallowed.

- Read Safety Data Sheets (SDSs) for handling instructions and to know the specific hazards of the fluids you are using, including the effects of long-term exposure.
- When spraying, servicing equipment, or when in the work area, always keep work area well-ventilated and always wear appropriate personal protective equipment. See **Personal Protective Equipment** warnings in this manual.
- Store hazardous fluid in approved containers, and dispose of it according to applicable guidelines.



## PERSONAL PROTECTIVE EQUIPMENT

Always wear appropriate personal protective equipment and cover all skin when spraying, servicing equipment, or when in the work area. Protective equipment helps prevent serious injury, including long-term exposure; inhalation of toxic fumes, mists or vapors; allergic reaction; burns; eye injury and hearing loss. This protective equipment includes but is not limited to:

- A properly fitting respirator, which may include a supplied-air respirator, chemically impermeable gloves, protective clothing and foot coverings as recommended by the fluid manufacturer and local regulatory authority.
- Protective eyewear and hearing protection.

# Important Isocyanate (ISO) Information

Isocyanates (ISO) are catalysts used in two component materials.

## Isocyanate Conditions



Spraying or dispensing fluids that contain isocyanates creates potentially harmful mists, vapors, and atomized particulates.

- Read and understand the fluid manufacturer's warnings and Safety Data Sheets (SDSs) to know specific hazards and precautions related to isocyanates.
- Use of isocyanates involves potentially hazardous procedures. Do not spray with this equipment unless you are trained, qualified, and have read and understood the information in this manual and in the fluid manufacturer's application instructions and SDSs.
- Use of incorrectly maintained or mis-adjusted equipment may result in improperly cured material. Equipment must be carefully maintained and adjusted according to instructions in the manual.
- To prevent inhalation of isocyanate mists, vapors, and atomized particulates, everyone in the work area must wear appropriate respiratory protection. Always wear a properly fitting respirator, which may include a supplied-air respirator. Ventilate the work area according to instructions in the fluid manufacturer's SDSs.
- Avoid all skin contact with isocyanates. Everyone in the work area must wear chemically impermeable gloves, protective clothing and foot coverings as recommended by the fluid manufacturer and local regulatory authority. Follow all fluid manufacturer recommendations, including those regarding handling of contaminated clothing. After spraying, wash hands and face before eating or drinking.

## Keep Components A and B Separate



Cross-contamination can result in cured material in fluid lines which could cause serious injury or damage equipment. To prevent cross-contamination:

- **Never** interchange component A and component B wetted parts.
- Never use solvent on one side if it has been contaminated from the other side.

## Moisture Sensitivity of Isocyanates

Exposure to moisture (such as humidity) will cause ISO to partially cure, forming small, hard, abrasive crystal that become suspended in the fluid. Eventually a film will form on the surface and the ISO will begin to gel, increasing in viscosity.

### NOTICE

Partially cured ISO will reduce performance and the life of all wetted parts.

- Always use a sealed container with a desiccant dryer in the vent, or a nitrogen atmosphere. **Never** store ISO in an open container.
- Keep the ISO pump wet cup or reservoir (if installed) filled with appropriate lubricant. The lubricant creates a barrier between the ISO and the atmosphere.
- Use only moisture-proof hoses compatible with ISO.
- Never use reclaimed solvents, which may contain moisture. Always keep solvent containers closed when not in use.
- Always lubricate threaded parts with an appropriate lubricant when reassembling.

**NOTE:** The amount of film formation and rate of crystallization varies depending on the blend of ISO, the humidity, and the temperature.

## Changing Materials

### **NOTICE**

Changing the material types used in your equipment requires special attention to avoid equipment damage and downtime.

- When changing materials, flush the equipment multiple times to ensure it is thoroughly clean.
- Always clean the fluid inlet strainers after flushing.
- Check with your material manufacturer for chemical compatibility.
- When changing between epoxies and urethanes or polyureas, disassemble and clean all fluid components and change hoses. Epoxies often have amines on the B (hardener) side. Polyureas often have amines on the B (resin) side.

# Installation

## Grounding



The equipment must be grounded to reduce the risk of static sparking. Static sparking can cause fumes to ignite or explode. Grounding provides an escape wire for the electric current.

Ground individual components by any of the following methods:

- Mount the component to a grounded conductive surface.
- Connect conductive fluid tubes to the component.
- Connect a ground wire to one of the component's mounting holes.

## Flush Before Using Equipment

The equipment was tested with lightweight oil, which is left in the fluid passages to protect parts. To avoid contaminating your fluid with oil, flush the equipment with a compatible solvent before using the equipment. See your proportioner manual for details.

## Color Change Stack

### Assemble a Color Change Stack

1. Lubricate the o-ring (4) and insert it in the housing's valve port.

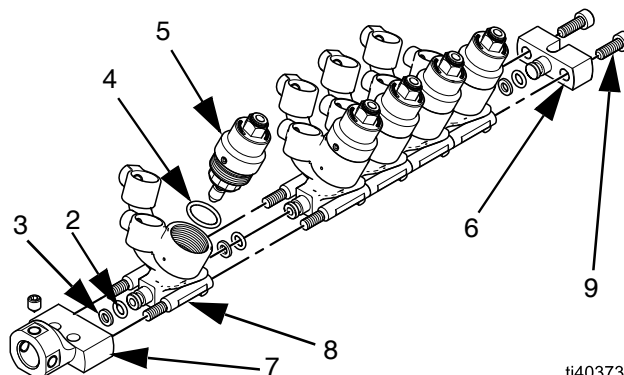

**FIG. 2: Color change stack assembly**

**NOTE:** This procedure is for the Quick Socket version of the color change stack kits, which connects the color change stack to non-IniFlex components. The IniFlex version of the color change stack kits includes a disposable shipping plug instead of the adapter connector (7), and is directly connected to other components with IniFlex fittings. The adapter connector (7) and shipping plug both connect to the tie rods (8) and hold the color change stack together during shipping.

2. Install the valve (5) in the valve port and torque to 80 in-lbs (9.0 N•m).
3. Repeat steps 1 and 2 for each valve in your color change stack.

**NOTE:** The maximum number of valves in a color change stack is 18.

4. Line up the adapter connector (7) and assembled valves (including seals (3), o-rings (2), and tie rods (8) in order of installation, with the valve closest to the adapter connector being first. Verify that the assembled valves are oriented with the fluid outlets directed towards the adapter connector (7), and that each fluid outlet has an o-ring (2) attached to it.
5. Assemble the segments for each tie rod (8) and hand-tighten.



6. Attach each assembled tie rod stack (8) to the input side of the adapter connector and torque each tie rod stack as an assembly to 35 in-lbs (4.0 N•m) at the furthest tie rod.
7. Lubricate the seal (3) of the first valve assembly and insert it in the adapter connector's (7) input port.
8. Slide the first valve assembly along the tie rods (8) snap the valve assembly's fluid outlet into the adapter connector's (7) input port.
9. Repeat steps 7 and 8 for each valve assembly.
10. Attach the end block (6) to the ends of the tie rods (8) and secure with the two screws (9). Torque to 35 in-lbs (4.0 N•m).

### Insert Additional Valves in a Color Change Stack

1. Repeat steps 1 and 2 of **Assemble a Color Change Stack**, page 16, for each new color change valve.
2. Loosen remove the screws (9) securing the end block (6) and remove the block.
3. Slide off enough valve assemblies from the tie rods (8) to make room for the new valve assembly.
4. Attach each assembled tie rod stack (8) to the input side of the adapter connector and torque each tie rod stack as an assembly to 35 in-lbs (4.0 N•m) at the furthest tie rod.
5. Repeat steps 7 and 8 of **Assemble a Color Change Stack**, page 16, for each new color change valve.
6. Slide on any remaining valve assemblies on the tie rods (8).
7. Attach the end block (6) to the ends of the tie rods (8) and secure with the two screws (9). Torque to 35 in-lbs (4.0 N•m). Tighten each tie rod stack evenly by alternating stacks until the torque spec is achieved.

### Connect Air and Fluid Tubes

1. Connect 5/32 in. (4 mm) OD air actuation tubes from the valve solenoids to the air inlets (A) of each valve. (See FIG. 3.)

**NOTE:** The color change valve uses a spring-operated valve closure (20) that does not require a second air actuation line.

\* See page 8 for available Graco fittings (FXF) and tubing.

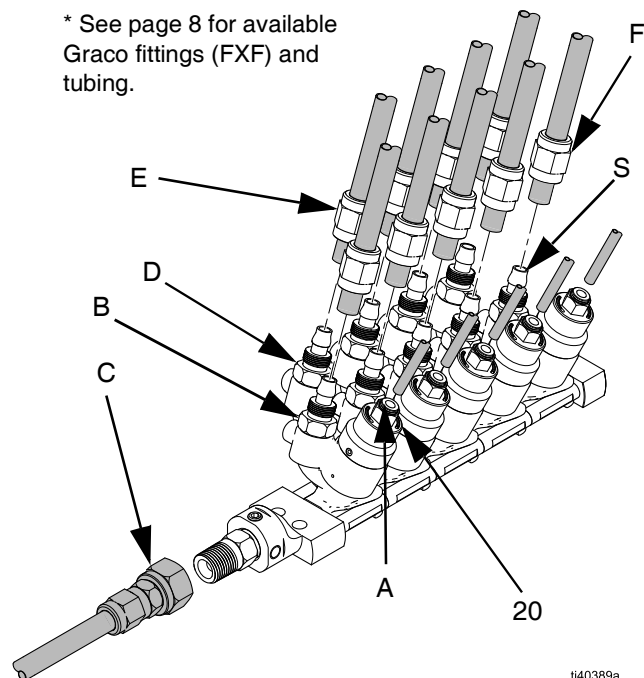

**FIG. 3: Connect air actuation tubes and fluid lines**

2. Connect fluid supply lines (E) to the Quick Socket fitting inlet port (B) of each valve adapter, and the solvent supply line (F) to one valve (S) at the top of the stack.

**NOTE:** For paint circulating systems: The color change valves have two fluid ports for each individual valve. If you are circulating paint, use one port for the inlet and the other for the outlet. For paint non-circulating systems: The color change valve has one fluid inlet port (B).

3. Connect the gun fluid supply line to the Quick Socket fluid outlet port (C) of the color change manifold.

**NOTE:** A check valve is recommended at the inlet of all valves to prevent backflow if a valve fails, and to prevent color crossover if two valves are actuated at the same time. See **Accessories**, page 28, for optional check valve kits.

## Switch Block

**NOTE:** The switch block is pre-configured in the configuration purchased. The following procedures describe how to attach color change stacks and to add a dump manifold, a gun flush manifold, a dump/purge plug, and fluid connections.

### Attach a Color Change Stack

**NOTE:** See **Assemble a Color Change Stack**, page 16, if you don't already have an already assembled color change stack.

1. Identify inlet sides 1 and 2 (numbers are etched in the bottom manifold (1)) and the gun flush manifold or plug (5 or 18). (See the **Switch Block** parts diagram on page 26 for the location of referenced parts.)
2. Remove the shipping piece (or adapter connector) and the end piece from the tie rods of the assembled color change stack.
3. Separate the tie rods from the color change stack (do not separate individual color change valves) and attach tie rods to the holes straddling the side 1 or side 2 port on the bottom manifold. Torque the tie rod stacks to 35 in-lbs (4.0 N•m).
4. Slide the color change stack on the tie rods and insert the fluid output port of the color change stack into the inlet port of the bottom switch block manifold.
5. Attach the end block (6) to the ends of the tie rods (8) and secure with the two screws (9). Torque to 35 in-lbs (4.0 N•m).

### Attach a Dump Manifold

**NOTE:** The following procedure assumes a dump manifold is replacing a dump plug. The procedure can also be used to replace an existing dump manifold.

1. Identify inlet sides 1 and 2 on the bottom manifold.
2. Loosen and remove the two screws (11 and 12) on top of the color manifold (3), and remove the dump plug (17) and o-ring (6) where the dump manifold (9) will be attached. Discard the o-ring (6). (See the

**Switch Block** parts diagram on page 26 for the location of referenced parts.)

3. Lubricate a new o-ring (6) and insert it in the port on top of the color manifold (3).
4. Align the slots in the dump manifold (9) with the holes in the color manifold (3), and secure with the two screws (11 and 12). Torque to 80-100 in-lb (9.0-11.3 N•m).

**NOTE:** The longer screw (11) is inserted in the hole closest to the outlet side of the switch manifold, and the shorter screw (12) is inserted in the hole towards the inlet side.

5. Lubricate the o-ring (16) and insert in it the valve port of the dump manifold (9).
6. Install the valve (4) in the valve port and torque to 80 in-lbs (9.0 N•m).

### Attach a Gun Flush Manifold

**NOTE:** The following procedure assumes a gun flush manifold is replacing a purge plug. The procedure can also be used to replace an existing gun flush manifold.

1. Loosen and remove the two screws (14) on side of the color manifold (3), and remove the purge plug (18) and o-ring (6). Discard the o-ring (6). (See the **Switch Block** parts diagram on page 26 for the location of referenced parts.)
2. Install the elbow fitting (10) in the top of the gun flush manifold (5) and orient as shown.
3. Lubricate a new o-ring (6) and insert it in the purge port on the side of the color manifold (3).
4. Align the holes in the gun flush manifold (5) with the holes in the color manifold (3), and secure with the two screws (14). Torque to 80-100 in-lb (9.0-11.3 N•m).
5. Lubricate the o-ring (16) and insert in it the valve port of the gun flush manifold (5).
6. Install the valve (4) in the valve port and torque to 80 in-lbs (9.0 N•m).

## Attach a Dump Plug

**NOTE:** The following procedure assumes a dump plug (17) is replacing a dump manifold (9). (See the **Switch Block** parts diagram on page 26 for the location of referenced parts.)

1. Identify inlet sides 1 and 2 on the bottom manifold.
2. Loosen and remove the two screws (11 and 12) on top of the color manifold (3), and remove the dump manifold (9) and o-ring (6) where the dump plug (9) will be attached. Discard the o-ring (6).
3. Lubricate a new o-ring (6) and insert it in the port on top of the color manifold (3).
4. Align the slots in the dump plug (17) with the holes in the color manifold (3), and secure with the two screws (11 and 12). Torque to 80-100 in-lb (9.0-11.3 N•m).

**NOTE:** The longer screw (11) is inserted in the hole towards the outlet side of the switch manifold, and the shorter screw (12) is inserted in the hole towards the inlet side.

## Attach a Purge Plug

**NOTE:** The following procedure assumes a purge plug (18) is replacing a gun flush manifold (5). (See the **Switch Block** parts diagram on page 26 for the location of referenced parts.)

1. Loosen and remove the two screws (14) on side of the color manifold (3), and remove the gun flush manifold (5) and o-ring (6). Discard the o-ring (6).
2. Lubricate a new o-ring (6) and insert it in the purge port on the of the color manifold (3).
3. Align the slots in the purge plug (18) with the holes in the color manifold (3), and secure with the two screws (14). Torque to 80-100 in-lb (9.0-11.3 N•m).

## Connect Air and Fluid Tubes

1. Connect 5/32 in. (4 mm) OD air actuation tubes from the valve solenoids to the air inlets (G) of each valve. (See FIG. 4.)

**NOTE:** The color change valve uses a spring-operated valve closure vent (20) that does not require a second air actuation line.

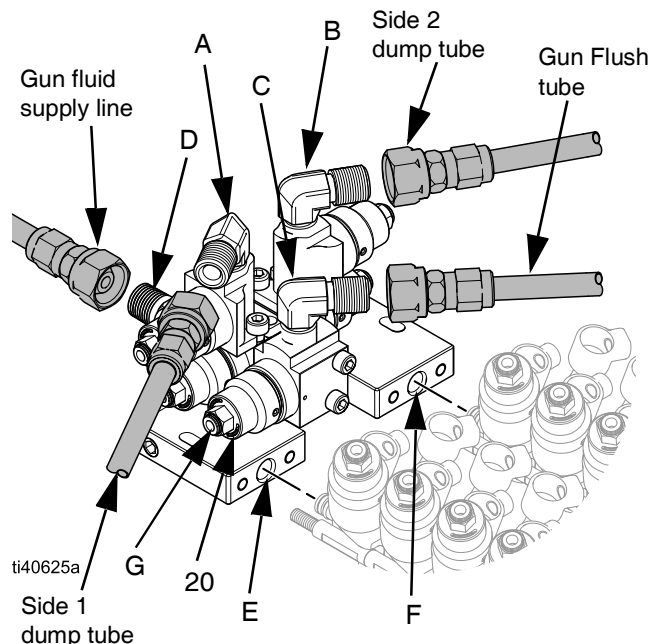
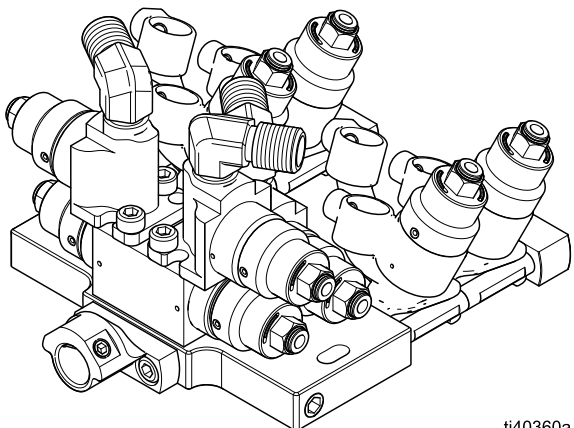

**FIG. 4: Connect fluid tubes to a switch block**

2. **Attach a Color Change Stack**, page 18, to the Side 1 (E) and Side 2 (F) inlets.
3. Connect the gun fluid supply line to the Quick Socket fluid outlet port (D) of the switch block.
4. Connect the Side 1 dump hose to the Side 1 Dump outlet port (A).
5. Connect the Side 2 dump tube to the Side 2 Dump outlet port (B).
6. Connect the Gun Flush tube to the Gun Flush outlet port (C)

## Auto Gun

**NOTE:** A pre-configured Auto Gun is a combination of a switch block and two color change stacks, and each stack consists of a color and a solvent. The configuration allows color change capability to be mounted close to the gun to optimize the time needed for quick color changes.



**Fig. 5: Pre-configured Auto Gun assembly**

The color change stack combinations for Auto Gun assemblies are limited to the following:

- 4 circulation and 0 non-circulation valves
- 0 circulation and 4 non-circulation valves
- 2 circulation and 2 non-circulation valves

See **Color Change Stack**, page 16, for additional connections to the color change stack, and **Switch Block**, page 18, for additional connections to the switch block.

## Additional Components

### Regulator

#### Attach a Regulator to a Color Change Stack

**NOTE:** See **Assemble a Color Change Stack**, page 16, if you don't already have an already assembled color change stack.

1. Remove the shipping piece (or adapter connector) and the end block (6) from the tie rods (8) of the assembled color change stack.
2. Separate the tie rods (8) from the color change stack (do not separate individual color change valves) and attach them to the holes straddling the inlet port on the base of the regulator. Torque the tie rod stacks to 35 in-lbs (4.0 N•m).
3. Slide the color change stack on the tie rods (8) and insert the fluid output port of the color change stack into the inlet port of the regulator.
4. Attach the end block (6) to the ends of the tie rods (8) and secure with the two screws (9). Torque to 35 in-lbs (4.0 N•m).

#### Attach a Regulator to a Dose/Mix Manifold

1. Align the holes in the regulator's base with the holes on the top of the central mix manifold block (1).
2. Verify that the orientation of the regulator's inlet port is the same as the dose/mix manifold, and secure the regulator with the four screws. (See the FXMM parts diagram in the related Fluid Mix Manifold manual, page 92, for the location of referenced parts.)

### Meter

#### Attach a Meter to a Color Change Stack

**NOTE:** See **Assemble a Color Change Stack**, page 16, if you don't already have an already assembled color change stack.

1. Lubricate a seal (3) and insert it in the inlet port in the base of the meter. (See FIG. 2, page 16.)
2. Align the two holes of the T-shaped spacer with the holes straddling the inlet port of the meter and secure with the two screws. Torque to 35 in-lbs (4.0 N•m).

3. Remove the shipping piece (or adapter connector) and the end block (6) from the tie rods (8) of the assembled color change stack.
4. Separate the tie rods (8) from the color change stack (do not separate individual color change valves) and attach them to the holes straddling the inlet port on the base of the meter. Torque the tie rod stacks to 35 in-lbs (4.0 N•m).
5. Slide the color change stack on the tie rods (8) and insert the fluid output port of the color change stack into the inlet port of the meter.
6. Attach the end block (6) to the ends of the tie rods (8) and secure with the two screws (9). Torque to 35 in-lbs (4.0 N•m).

#### Attach a Meter to a Switch Block

**NOTE:** This procedure requires model FX250XK (see **Meter Model Numbers** on page 7) or separate IniFlex links. This procedure describes how connect the inlet port of an IniFlex meter to the outlet port of an IniFlex switch block.

1. Lubricate an o-ring and insert it in the inlet port in the base of the meter.
2. Align the two holes of the T-shaped spacer with the holes straddling the inlet port of the meter and secure with the two screws. Torque to 35 in-lbs (4.0 N•m).
3. Lubricate an o-ring and insert it in the outlet port in the base of the switch block.
4. Align the two holes of the IniFlex link with the holes straddling the outlet port of the switch block and

secure with the two screws. Torque to 35 in-lbs (4.0 N•m).

5. Insert the stem of the T-shaped spacer in the switch block's outlet port and secure with the setscrew. Torque to 50 in-lbs (5.6 N•m).

#### Attach a Meter to a Regulator or a Dose/Mix Manifold

**NOTE:** This procedure requires model FX250XT (see **Meter Model Numbers** on page 7) or a separate T-shaped spacer and IniFlex link. This procedure describes how the outlet port of an IniFlex meter is connected to the inlet port of an IniFlex regulator or dose/mix manifold.

1. Lubricate an o-ring and insert it in the outlet port in the base of the meter.
2. Align the two holes of the IniFlex link with the holes straddling the outlet port of the meter and secure with the two screws. Torque to 35 in-lbs (4.0 N•m).
3. Lubricate an o-ring and insert it in the inlet port in the base of the regulator or dose/mix manifold.
4. Align the holes in the IniFlex link connector block with the holes straddling the inlet port of the regulator or dose/mix manifold, and secure with two screws. Torque to 35 in-lbs (4.0 N•m).
5. Insert the stem of the T-shaped spacer in the meter's outlet port and secure with the setscrew. Torque to 50 in-lbs (5.6 N•m).

## Typical Configurations

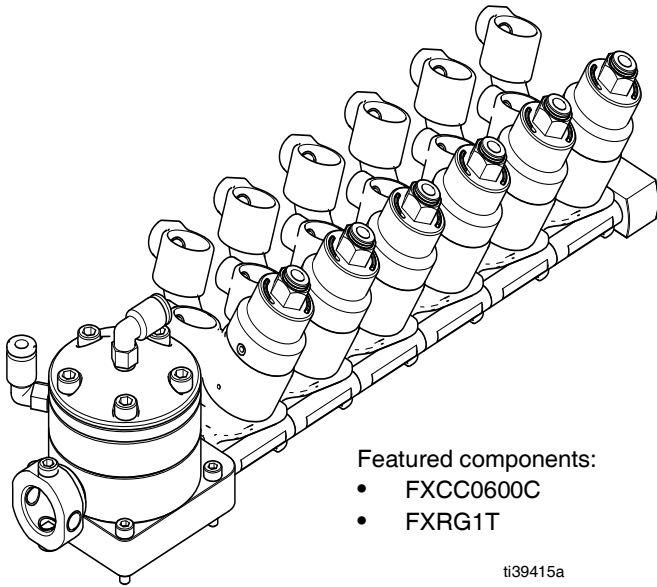

- Featured components:
- FXCC0600C
  - FXRG1T

ti39415a

**FIG. 6: 1K Single color manifold without flow control**

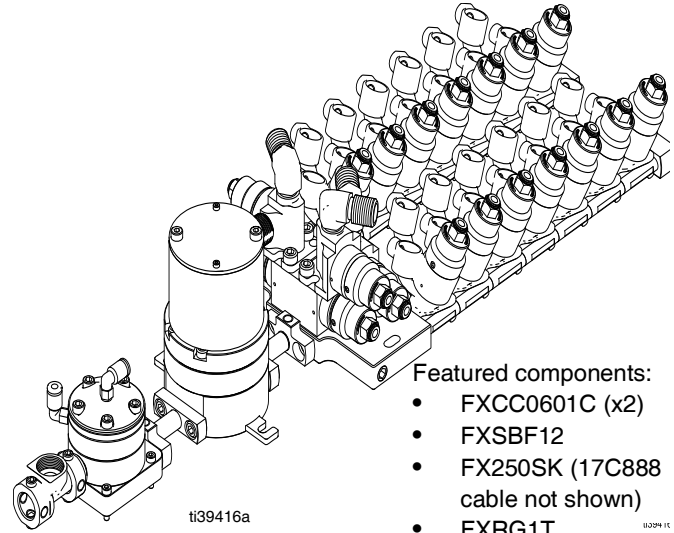

Featured components:

- FXCC0601C (x2)
- FXSBF12
- FX250SK (17C888 cable not shown)
- FXRG1T

ti39416a

ti39416

**FIG. 7: 1K Dual color manifold with flow control**

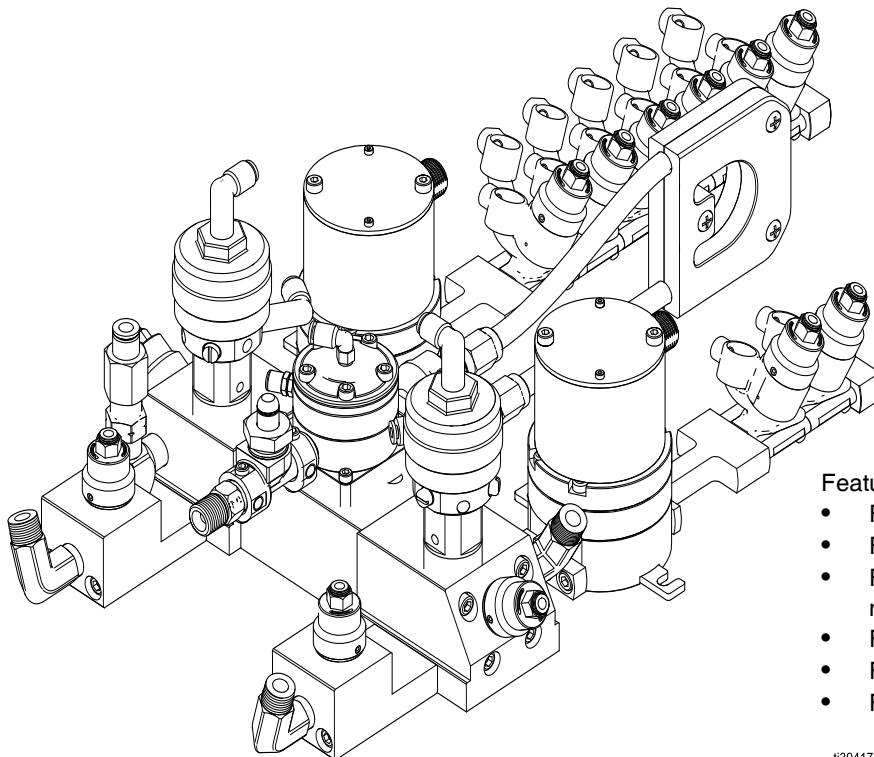

Featured components:

- FXCC0501C
- FXCC0002C
- FX250ST (17C888 cable not shown) (x2)
- FXMMAB
- FXF010
- FXRG1TM

ti39417a

**FIG. 8: 2K Single color manifold with flow control**

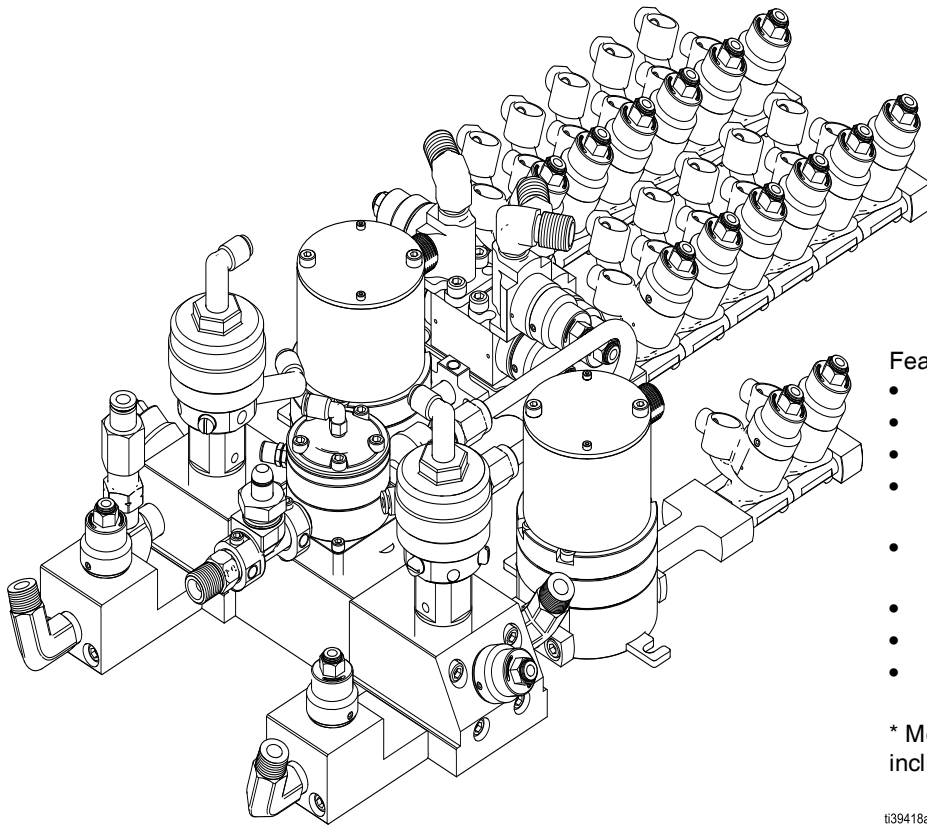

Featured components:

- FXCC0501C (x2)
- FXSBF12
- FXCC0002C
- FX250SK (17C888\* cable not shown)
- FX250ST (17C888\* cable not shown)
- FXMMAB
- FXRG1TM
- FXF010

\* Meter cable 17C888 (50 ft.) is included with the meter.

ti39418a

**FIG. 9: 2K Dual color manifold with flow control**

# Parts

**NOTE:** Refer to **Related Manuals**, page 2, for the parts of other components.

## Pre-Configured Color Change Stack

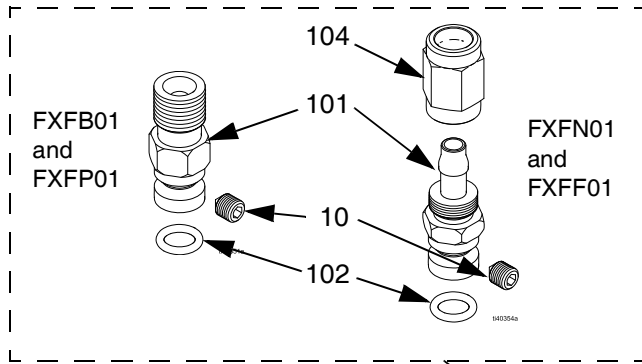

Fittings, see page 8, installed here.

- 1 Apply lubricant to all o-rings.
- 2 Torque each tie rod (8) and cap screw (9) to 35 in-lb (47.5 N•m).
- 3 Torque item 5 to 80 in-lb (9.0 N•m).

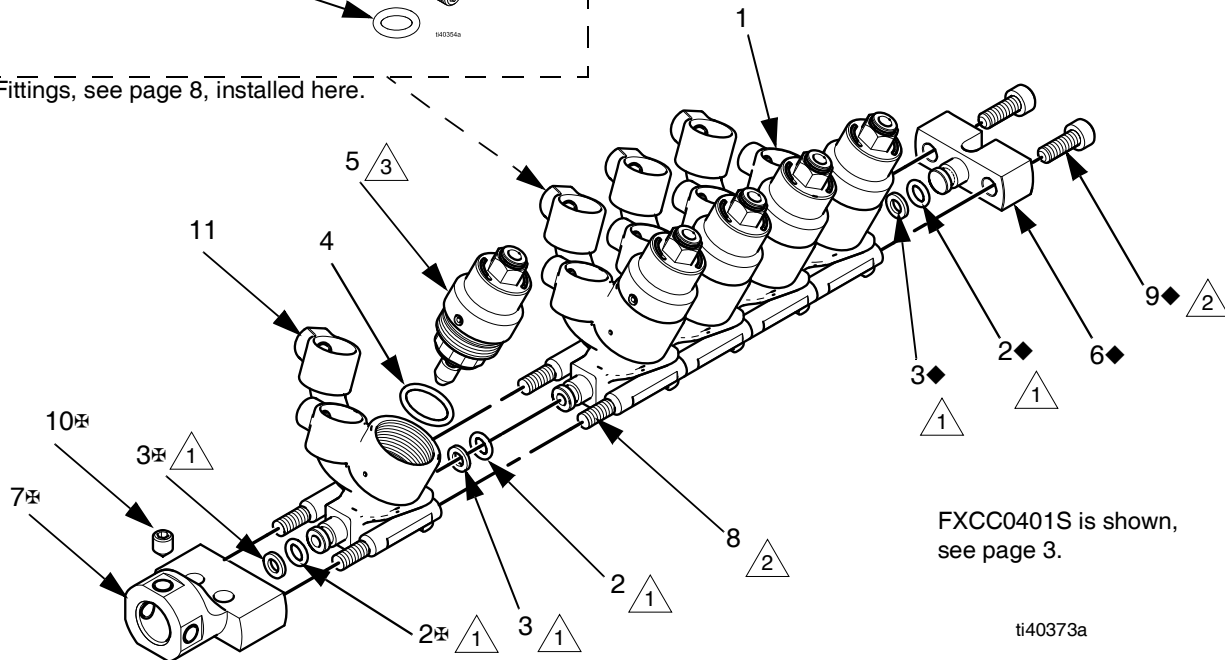

See **Technical Specifications**, page 33, for component weights.



## Pre-Configured Color Change Stack Parts List

Ref.	Part	Description	Qty
1 ‡	---	HOUSING, non-circ ccv	1 per non-circ ccv
2 ‡ ‡ ‡ ◆	111516	PACKING, o-ring	1 + ref 1 + ref 11
3 ‡ ‡ ‡ ◆	---	SEAL	1 + ref 1 + ref 11
4	---	PACKING, o-ring	ref 1 + ref 11
5	26B108	VALVE, air actuated dispense	ref 1 + ref 11
6 ◆	---	BLOCK, end	1
7 ‡	19C887	CONNECTOR, adapter	1
8	---	ROD, tie	2 x (ref 1 + ref 11)
9 ◆	120885	SCREW, M5x14mm	2
10 ‡ ‡	---	SCREW, socket, cone point, M6x8mm	1 + ref 1 + (2 x ref 11)
11 ‡	---	HOUSING, circ ccv	1 per circ ccv
101*	---	COUPLING, tube	ref 1 + (2 x ref 11)
102*	---	O-RING, FX75	ref 1 + (2 x ref 11)
104**	---	NUT, retainer, tube	ref 1 + (2 x ref 11)
<p><b>NOTE:</b> "ref 1" and "ref 11" refer to the quantities on this parts list of non-circulation and circulation valves, respectively.</p> <p>For example, the quantity for the o-ring in row 2 would be equal to one plus the quantities from rows 1 and 11. For Color Change Stack FXCC0402C, which has two non-circulation valves and four circulation valves, the quantity of 111516 o-rings in row 2 would be 1+2+4=7.</p>			

\* Included with all FXF Fitting Models. See **Quick Socket Fitting Model Numbers**, page 8.

\*\* Included with FXFN and FXFF Fitting Models, includes FXF Fitting Models. See **Quick Socket Fitting Model Numbers**, page 8.

‡ Included with FXCC0100 Circulation Valve Kit. See **Pre-Configured Color Change Stack Model Numbers**, page 3.

‡ Included with FXCC0001 Non-Circulation Valve Kit. See **Pre-Configured Color Change Stack Model Numbers**, page 3.

‡ Included with FXCCKT1 Color Change Outlet Block Kit.

◆ Included with FXCCKT2 Color Change End Block Kit.

## Additional Pre-Configured Color Change Stack Kits

Part No.	Description
102982BLK10	IniFlex O-Ring Valve Kit (includes ref. 4 (x10))
131388BLK10	IniFlex Quick Socket O-Ring Kit (includes ref. 102 (x10))
131517BLK50	IniFlex Quick Socket Set Screw Kit (includes ref. 10 (x50))
26B108BLK5	IniFlex Valve with O-Ring Kit (includes ref. 4 (x5) and 5 (x5))
17S613BLK10	IniFlex Color Change Face Seal Kit (includes ref. 3 (x10))
111516BLK10	IniFlex Color Change Stem O-Ring Kit (includes ref. 2 (x10))
19B862BLK20	IniFlex Color Change Tie Rod Kit (includes ref. 8 (x20))

# Switch Block

1 Apply lubricant to all o-rings.

2 Torque items 11-14 to 80 - 100 in-lb (9.0 - 11.3 N•m).

3 Orient item 10 as shown.

4 Torque item 4 to 80 in-lb (9.0 N•m).

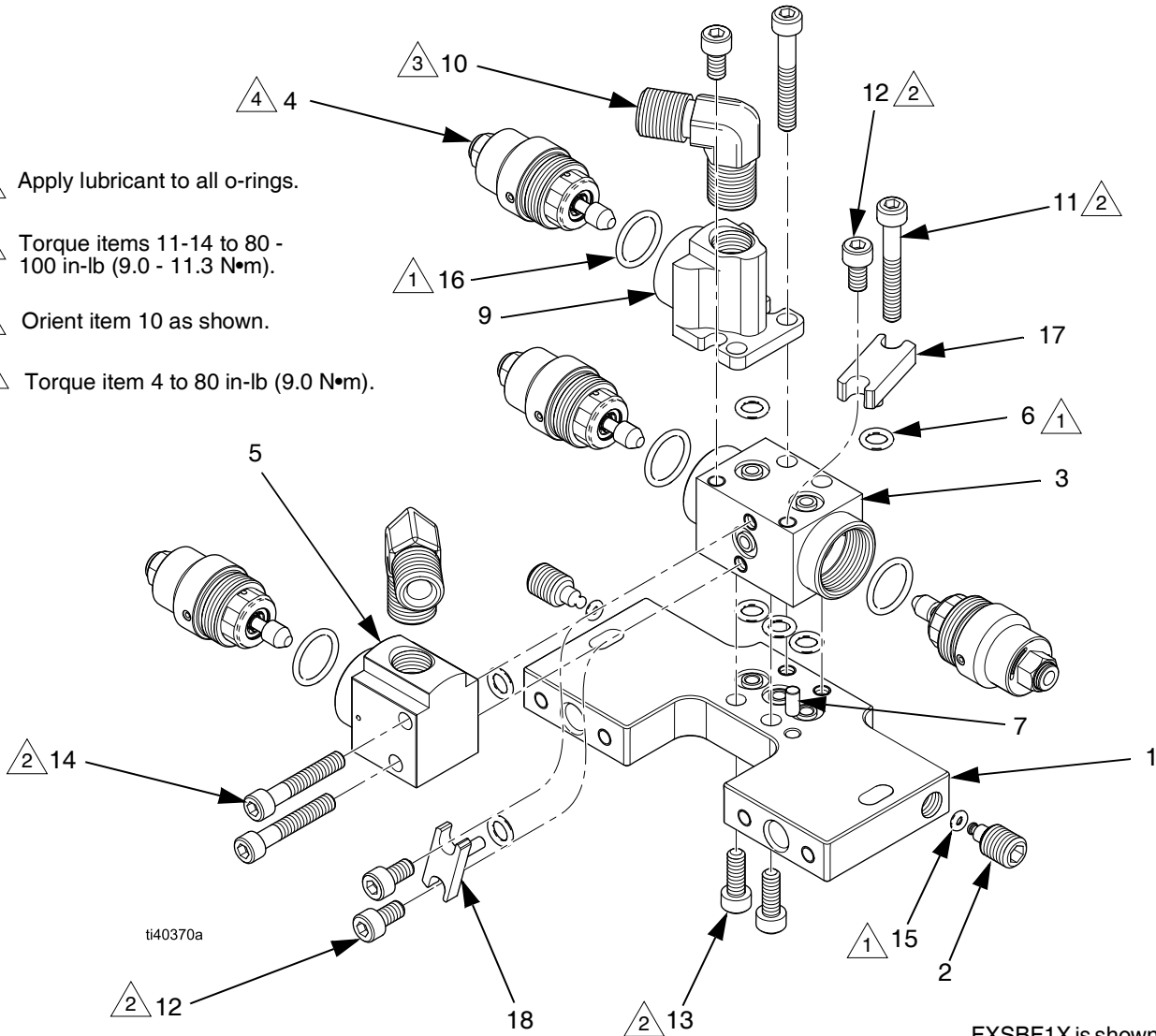

See **Technical Specifications**, page 33, for component weights.

FXSBF1X is shown, see page 5.

## Switch Block Parts List

Ref.	Part	Description	Quantity by Model							
			FXSBF12	FXSBF1X	FXSBFX2	FXSBFXX	FXSBX12	FXSBX1X	FXSBXX2	FXSBXXX
1	---	MANIFOLD, switch block, bottom	1	1	1	1	1	1	1	1
2	---	PLUG, dose pump	2	2	2	2	2	2	2	2
3	---	MANIFOLD, switch block, color	1	1	1	1	1	1	1	1
4	26B108	VALVE, color change	5	4	4	3	4	3	3	2
5	---	MANIFOLD, switch block, purge	1	1	1	1	--	--	--	--
6	---	O-RING	6	6	6	6	6	6	6	6
7	192387	PIN, dowel	1	1	1	1	1	1	1	1
9	---	MANIFOLD, switch block, dump	2	1	1	--	2	1	1	--
10	---	ELBOW, 1/4-18 npsm	3	2	2	1	2	1	1	--
11	---	SCREW, shcs M5 x 35 mm	2	2	2	2	2	2	2	2
12	---	SCREW, shcs M5 x 10 mm	2	2	2	2	4	4	4	4
13	---	SCREW, shcs M5 x 14 mm	2	2	2	2	2	2	2	2
14	---	SCREW, shcs M5 x 30 mm	2	2	2	2	--	--	--	--
15	---	O-RING, ptfе	2	2	2	2	2	2	2	2
16	---	O-RING	5	5	5	5	4	3	3	2
17	---	PLUG, switch block, dump	--	1	1	2	--	1	1	2
18	---	PLUG, switch block, purge	--	--	--	--	1	1	1	1
19	---	LUBRICANT, grease (not shown)	1	1	1	1	1	1	1	1

## Additional Switch Block Kits

Part No.	Description
FXSBKT1	IniFlex Switch Block Seal Rebuild Kit (includes ref. 6 (x6), 15 (x2), and 16 (x5))
FXSBKT2	IniFlex Switch Block Dump Plug Kit (includes ref. 6, 11,12, and 17)
FXSBKT3	IniFlex Switch Block Purge Plug Kit (includes ref. 6, 12 (x2), and 18)
FXSBKT4	IniFlex Switch Block Dump Kit (Includes ref. 4, 6, 9, 11, 12, and 16)
FXSBKT5	IniFlex Switch Block Purge Kit (includes ref. 4, 5, 6, 14 (x2), and 16)

## Accessories

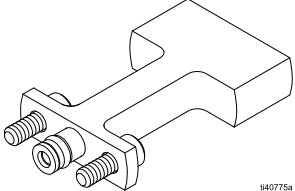
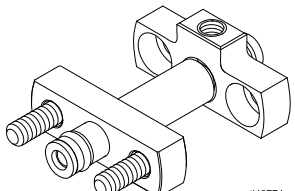
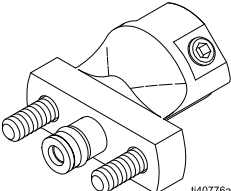
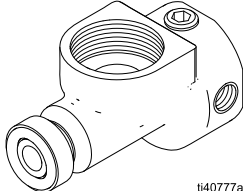
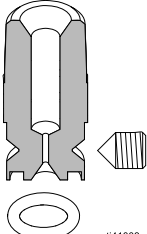
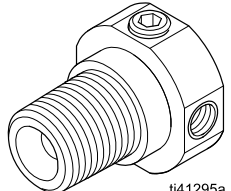
Part No.	Description	
FXKT01	FXCC Connection  ti40775a	The FXCC Connection is used to attach the color stack to the meter. This piece provides space between the meter and color valve stacks to allow connection of the meter cable.
FXKT02	IniFlex Link  ti40774a	The IniFlex Link is used to link two IniFlex components together.
FXKT03	Quick Socket Fitting  ti40776a	The Quick Socket Fitting is used to adapt an IniFlex connection to a quick socket connection. The quick socket allows for adaptation to any of the FXF fitting models.
FXKT04	Transducer Fitting  ti40777a	The Transducer Fitting allows for a pressure transducer fitting to be added to a regulator for Graco flow control applications. This is only needed if the regulator was ordered without this fitting. The quick socket allows for adaption to any of the FXF fitting styles.
FXF010 FXF014 FXF020 FXF029 FXF040	Fluid Flow Restrictor  ti41003a	The Fluid Flow Restrictor for flow control applications to increase fluid pressure to the applicator, allowing the fluid regulator and transducer to operate in a more responsive range.
FXKT05	Quick Socket Fitting to 1/4 in. NPT(m)  ti41295a	This Quick Socket Fitting is for general-purpose use to convert a male Quick Socket connection to 1/4" NPT(m).

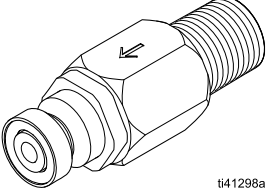
Part No.	Description	
26D230	<p data-bbox="315 260 727 285">Quick Socket 1/4 in. NPT Check Valve</p>  <p data-bbox="646 474 699 485">ti41298a</p>	<p data-bbox="834 260 1334 432">The Quick Socket Check Valve is to be used on color change valves to prevent color backflow if a valve were stuck open. A check valve should always be used on the air chop valves to prevent paint or solvent backflowing into the air supply system.</p>

# Assembly Mounting Holes

## Simple Color Change Stack

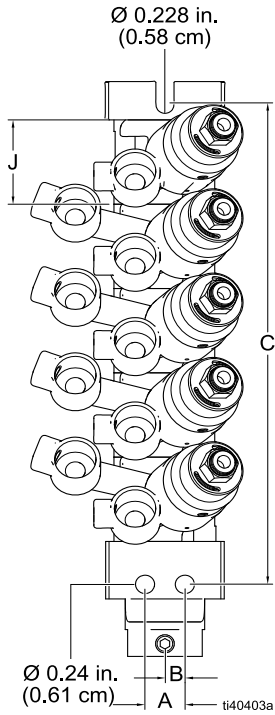

Dimensions		
<b>A</b>	0.50 in.	1.27 cm
<b>B</b>	0.25 in.	0.64 cm
<b>C*</b>	6.26 in.	15.90 cm
<b>J*</b>	1.1 in.	2.8 cm

\* Each additional color change valve will add dimension J to dimension C.

See **Technical Specifications**, page 33, for component weights.

## Color Change Stack w/Regulator

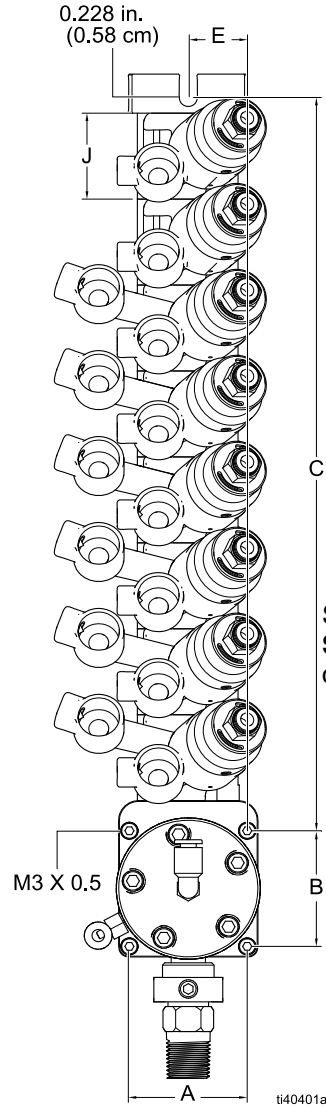

Dimensions		
<b>A</b>	1.48 in.	3.76 cm
<b>B</b>	1.48 in.	3.76 cm
<b>C*</b>	9.39 in.	23.84 cm
<b>E</b>	0.74 in.	1.88 cm
<b>J*</b>	1.1 in.	2.8 cm

\* Each additional color change valve will add dimension J to dimension C.

See **Technical Specifications**, page 33, for component weights.

### Switch Block with 2 Color Change Stacks, a Meter, and a Regulator

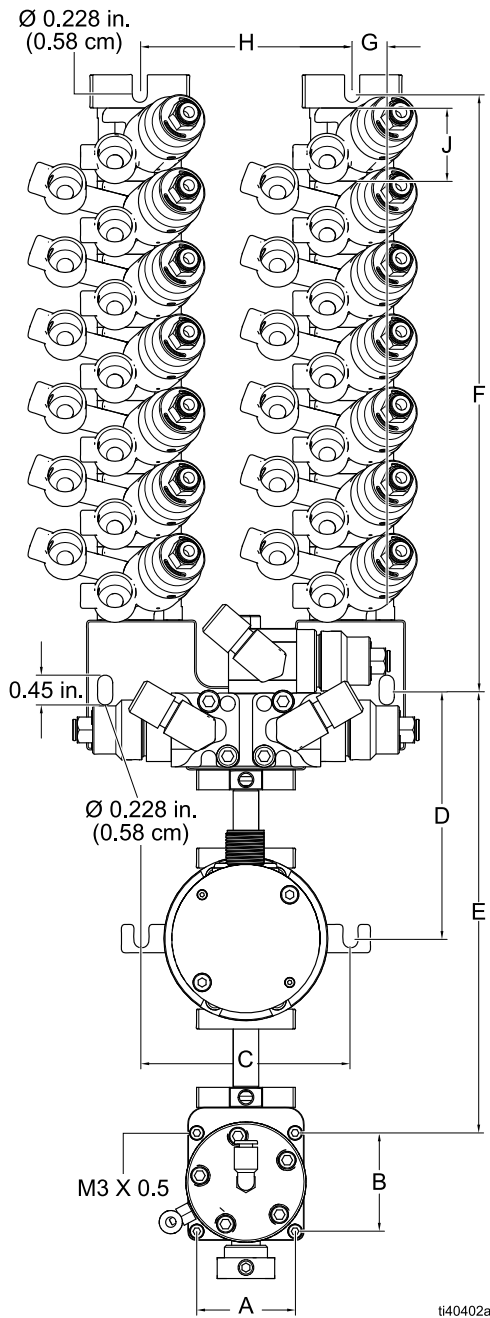

Dimensions		
<b>A</b>	1.48 in.	3.76 cm
<b>B</b>	1.48 in.	3.76 cm
<b>C</b>	3.15 in.	8.00 cm
<b>D</b>	3.67 in.	9.32 cm
<b>E</b>	6.48 in.	16.45 cm
<b>F*</b>	8.95 in.	22.7 cm
<b>G</b>	0.52 in.	1.32 cm
<b>H</b>	3.20 in.	8.13 cm
<b>J*</b>	1.1 in.	2.8 cm

\* Each additional color change valve will add dimension J to dimension F.

See **Technical Specifications**, page 33, for component weights.

**Mix Manifold with 2 Color Change Stacks,  
2 Meters, and a Regulator**

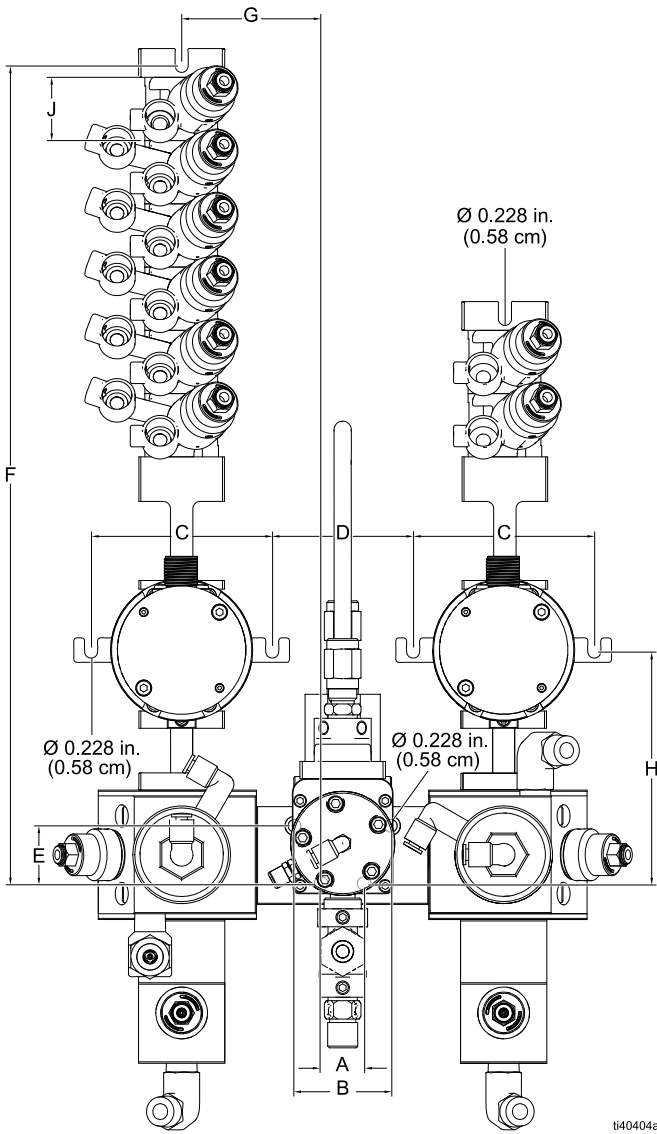

Dimensions		
<b>A</b>	0.75 in.	1.91 cm
<b>B</b>	1.68 in.	4.26 cm
<b>C</b>	3.15 in.	8.00 cm
<b>D</b>	2.45 in.	6.22 cm
<b>E</b>	1.01 in.	2.56 cm
<b>F*</b>	14.22 in.	36.12 cm
<b>G</b>	2.43 in.	6.16 cm
<b>H</b>	4.04 in.	10.25 cm
<b>J*</b>	1.1 in.	2.8 cm

\* Each additional color change valve will add dimension J to dimension F.

See **Technical Specifications**, page 33, for component weights.

# California Proposition 65

## CALIFORNIA RESIDENTS

**⚠ WARNING:** Cancer and reproductive harm – [www.P65warnings.ca.gov](http://www.P65warnings.ca.gov).



# Technical Specifications

<b>IniFlex™</b>		
	<b>US</b>	<b>Metric</b>
Maximum fluid working pressure (all models)	300 psi	2.1 MPa, 21 bar
Maximum air input pressure (all models)	100 psi	0.7 MPa, 7 bar
<b>Inlet/Outlet Sizes</b>		
Fluid Inlet	IniFlex	
FXMM, FXSB, FX250, FXRG	IniFlex	
Fluid Outlet	IniFlex	
FXSB, FX250, FXRG	IniFlex	
FXMM	1/4 in. npt(f)	
Air Inlet	5/32 in. (4 mm) OD tube fitting	
FXCC, FXMM, FXSB, FXRG	5/32 in. (4 mm) OD tube fitting	
<b>Materials of Construction</b>		
Wetted materials	301, 303, 316 SST; 17-4 PH SST; UHMWPE, FX75 (chemically-resistant Viton)	
FXCC, FXSB, FXAG	301, 303, 316 SST; 17-4 PH SST; UHMWPE, FX75 (chemically-resistant Viton)	
FXMM	301, 303, 316 SST; 17-4 PH SST; Tungsten Carbide; PTFE; PEEK; UHMWPE	
FX250	303 SST, Tungsten Carbide, PTFE	
FXF	316 SST, FX75 (chemically-resistant Viton)	
FXRG	303, 17-4 PH SST; PTFE; FFKM	
<b>Component Weights</b>		
Meter (FX250ST)	2.60 lb	1.18 kg
Fluid Regulator (FXRG11)	1.00 lb	0.45 kg
Color Stacks		
FXCC0401, w/o connector fitting	1.67 lb	0.76 kg
Each additional circulation valve	0.33 lb	0.15 kg
Each additional non-circulation valve	0.27 lb	0.12 kg
FXCC0401, with Quick Socket fittings	2.27 lb	1.03 kg
Each additional circulation valve	0.47 lb	0.21 kg
Each additional non-circulation valve	0.33 lb	0.15 kg
Mix Manifold		
FXMMXX	10.50 lb	4.76 kg
FXMMAX	11.00 lb	4.99 kg
FXMMXB	11.00 lb	4.99 kg
FXMMAB	11.50 lb	5.22 kg
Splitter Block		
FXSB1XX	2.27 lb	1.03 kg
FXSB11X	2.60 lb	1.18 kg
FXSB112	2.92 lb	1.32 kg
<b>Notes</b>		
All trademarks or registered trademarks are the property of their respective owners.		

# Graco Standard Warranty

Graco warrants all equipment referenced in this document which is manufactured by Graco and bearing its name to be free from defects in material and workmanship on the date of sale to the original purchaser for use. With the exception of any special, extended, or limited warranty published by Graco, Graco will, for a period of twelve months from the date of sale, repair or replace any part of the equipment determined by Graco to be defective. This warranty applies only when the equipment is installed, operated and maintained in accordance with Graco's written recommendations.

This warranty does not cover, and Graco shall not be liable for general wear and tear, or any malfunction, damage or wear caused by faulty installation, misapplication, abrasion, corrosion, inadequate or improper maintenance, negligence, accident, tampering, or substitution of non-Graco component parts. Nor shall Graco be liable for malfunction, damage or wear caused by the incompatibility of Graco equipment with structures, accessories, equipment or materials not supplied by Graco, or the improper design, manufacture, installation, operation or maintenance of structures, accessories, equipment or materials not supplied by Graco.

This warranty is conditioned upon the prepaid return of the equipment claimed to be defective to an authorized Graco distributor for verification of the claimed defect. If the claimed defect is verified, Graco will repair or replace free of charge any defective parts. The equipment will be returned to the original purchaser transportation prepaid. If inspection of the equipment does not disclose any defect in material or workmanship, repairs will be made at a reasonable charge, which charges may include the costs of parts, labor, and transportation.

**THIS WARRANTY IS EXCLUSIVE, AND IS IN LIEU OF ANY OTHER WARRANTIES, EXPRESS OR IMPLIED, INCLUDING BUT NOT LIMITED TO WARRANTY OF MERCHANTABILITY OR WARRANTY OF FITNESS FOR A PARTICULAR PURPOSE.**

Graco's sole obligation and buyer's sole remedy for any breach of warranty shall be as set forth above. The buyer agrees that no other remedy (including, but not limited to, incidental or consequential damages for lost profits, lost sales, injury to person or property, or any other incidental or consequential loss) shall be available. Any action for breach of warranty must be brought within two (2) years of the date of sale.

**GRACO MAKES NO WARRANTY, AND DISCLAIMS ALL IMPLIED WARRANTIES OF MERCHANTABILITY AND FITNESS FOR A PARTICULAR PURPOSE, IN CONNECTION WITH ACCESSORIES, EQUIPMENT, MATERIALS OR COMPONENTS SOLD BUT NOT MANUFACTURED BY GRACO.** These items sold, but not manufactured by Graco (such as electric motors, switches, hose, etc.), are subject to the warranty, if any, of their manufacturer. Graco will provide purchaser with reasonable assistance in making any claim for breach of these warranties.

In no event will Graco be liable for indirect, incidental, special or consequential damages resulting from Graco supplying equipment hereunder, or the furnishing, performance, or use of any products or other goods sold hereto, whether due to a breach of contract, breach of warranty, the negligence of Graco, or otherwise.

## **FOR GRACO CANADA CUSTOMERS**

The Parties acknowledge that they have required that the present document, as well as all documents, notices and legal proceedings entered into, given or instituted pursuant hereto or relating directly or indirectly hereto, be drawn up in English. Les parties reconnaissent avoir convenu que la rédaction du présente document sera en Anglais, ainsi que tous documents, avis et procédures judiciaires exécutés, donnés ou intentés, à la suite de ou en rapport, directement ou indirectement, avec les procédures concernées.

# Graco Information

For the latest information about Graco products, visit [www.graco.com](http://www.graco.com).

For patent information, see [www.graco.com/patents](http://www.graco.com/patents).

**TO PLACE AN ORDER**, contact your Graco distributor or call to identify the nearest distributor.

**Phone:** 612-623-6921 **or Toll Free:** 1-800-328-0211 **Fax:** 612-378-3505

*All written and visual data contained in this document reflects the latest product information available at the time of publication. Graco reserves the right to make changes at any time without notice.*

Original instructions. This manual contains English. MM 3A8637

**Graco Headquarters:** Minneapolis

**International Offices:** Belgium, China, Japan, Korea

**GRACO INC. AND SUBSIDIARIES • P.O. BOX 1441 • MINNEAPOLIS MN 55440-1441 • USA**  
**Copyright 2021, Graco Inc. All Graco manufacturing locations are registered to ISO 9001.**

[www.graco.com](http://www.graco.com)  
Revision C, March 2022