

# 15U933 and 24T817 Rebuild Kits

Use 15U933 for 15X303 High Pressure Dispense Valve  
 Use 24T817 for 24T785 and 26A313 High Pressure Valve for  
 Acid Catalyzed Materials

406714D

EN



### Important Safety Instructions

Read all warnings and instructions in manuals 312782, 332339, and 332562. Save those instructions.

⚠ Apply thread sealant to needle shaft before installing ball assembly (23).

Ref.	Description	Qty.
4	SEAL, u-cup, spring applied; uhmwpe	1
5	BEARING, needle	1
7	O-RING, shaft, piston; buna-N	1
8	O-RING, body, piston; buna-N	1
17	O-RING, body, air; buna-N	1
19	PACKING; uhmwpe	1
20	O-RING; ptfе	1
22	SHAFT, needle	1
23	BALL ASSEMBLY, needle	1

NOTE: 24T817 contains extra parts that are not used in rebuilding the valve. Discard one valve seat retainer (27) and one PTFE o-ring (28), or use those parts when installing the valve in a PD2K application:

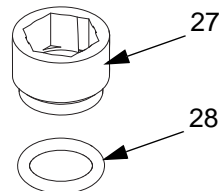

TI29428A

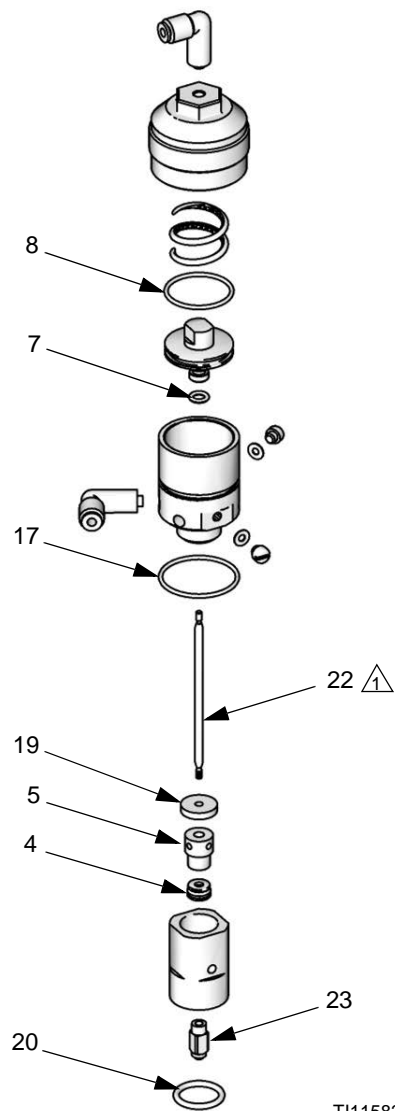

TI11582A

## Graco Information

For the latest information about Graco products, visit [www.graco.com](http://www.graco.com).

For patent information, see [www.graco.com/patents](http://www.graco.com/patents).

**TO PLACE AN ORDER**, contact your Graco distributor or call to identify the nearest distributor.

**Phone:** 612-623-6921 **or Toll Free:** 1-800-328-0211 **Fax:** 612-378-3505

*All written and visual data contained in this document reflects the latest product information available at the time of publication.  
Graco reserves the right to make changes at any time without notice.*

Original instructions. This manual contains English. MM 406714

**Graco Headquarters:** Minneapolis

**International Offices:** Belgium, China, Japan, Korea

**GRACO INC. AND SUBSIDIARIES • P.O. BOX 1441 • MINNEAPOLIS MN 55440-1441 • USA**  
**Copyright 2008, Graco Inc. All Graco manufacturing locations are registered to ISO 9001.**

[www.graco.com](http://www.graco.com)

Revision D, October 2016