

Bolt-Through Diaphragm and Fluid Section Repair Kits

407090D

Husky® 2200 Diaphragm Pumps

EN



Important Safety Instructions

Read all warnings and instructions in the Husky® 2200 Air-Operated Diaphragm Pump Repair/Parts manual 3A2714. Save all instructions.

Kits 24V242, 25A868, 25A870, Santoprene® Kit 24V243, FKM

Ref.	Description	Qty.
12	DIAPHRAGM, material shown at left	2
302	TOOL, diaphragm install	1
----	ADHESIVE, anaerobic (not shown)	1
The following included in 25A868 or 25A870 only		
----	BALL (not shown), Santoprene	4
----	SEAT (not shown), polypropylene (25A868), Santoprene (25A870)	4
----	O-RING, PTFE (not shown)	8

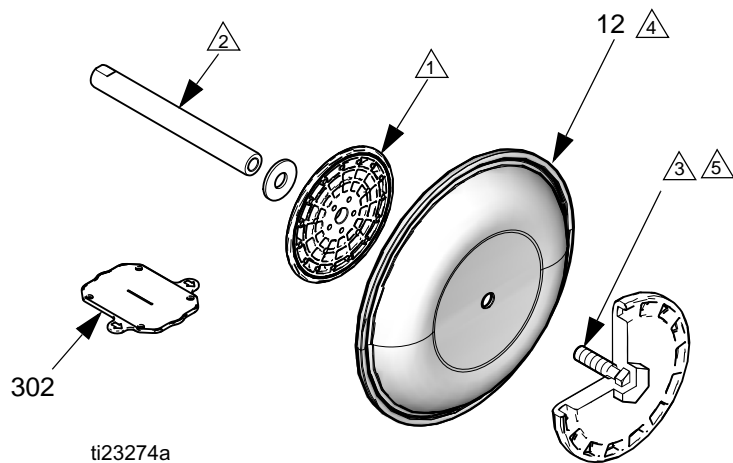

- ① Rounded side faces diaphragm.
- ② Apply lithium-based grease.
- ③ Torque to 100-105 ft-lb. (136-142 N•m) at 100 rpm maximum.
- ④ AIR SIDE markings on diaphragm must face center housing.
- ⑤ Apply primer and medium-strength adhesive (supplied) to shaft side threads.

GRACO INC. AND SUBSIDIARIES • P.O. BOX 1441 • MINNEAPOLIS MN 55440-1441 • USA

Copyright 2014, Graco Inc. All Graco manufacturing locations are registered to ISO 9001.

407090, Rev. D, December 2016