

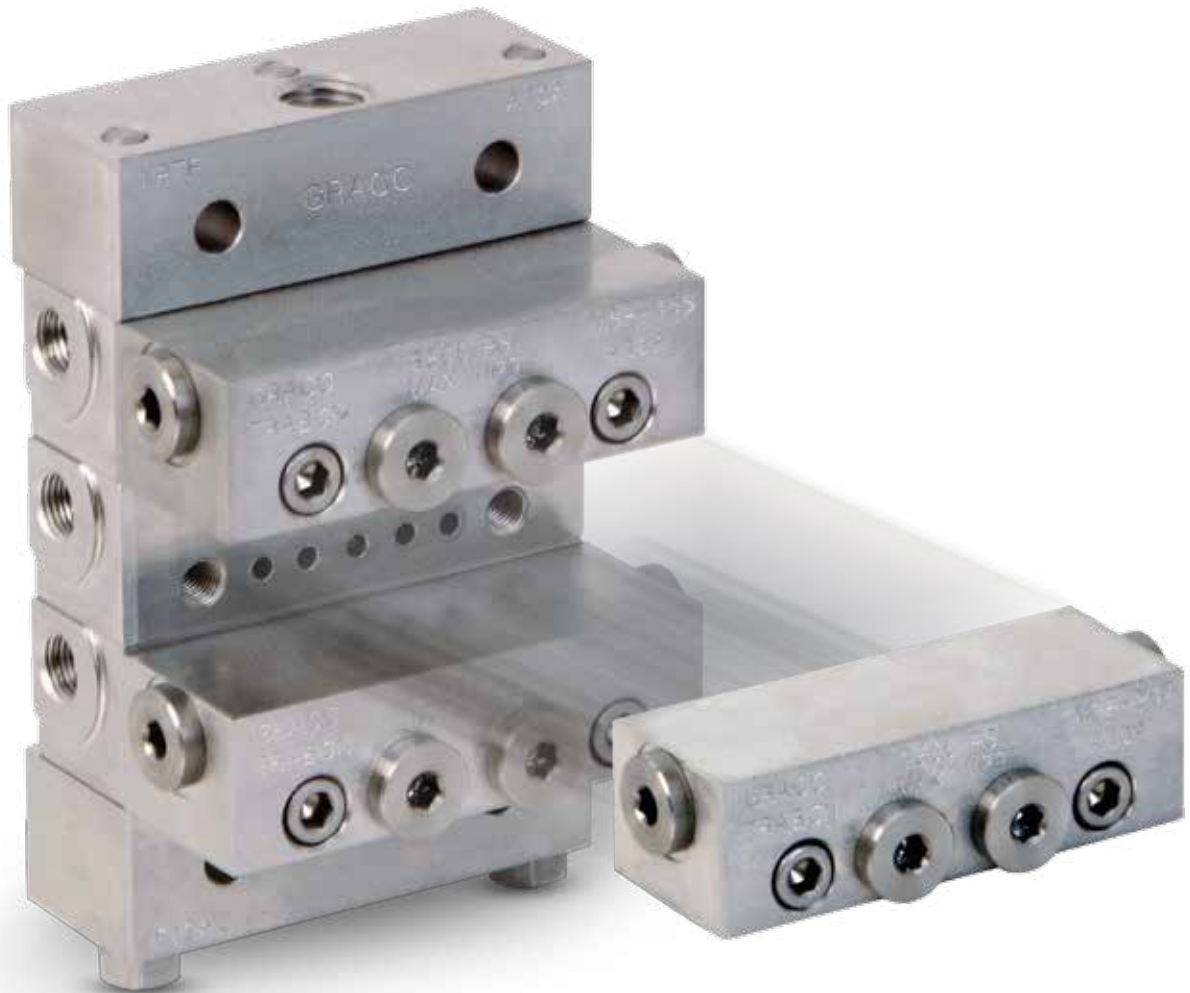

Trabon[®] MSP Modular Divider Valves



**The industry standard for quality, reliability,
and ease-of-use features.**

Match lubricant flow to the exact needs of each point.

- Precise monitoring, positive feedback
- Simple to install and operate
- Modular design for total flexibility

The flexible, modular MSP Divider Valve

- For lubrication oil or grease up to NLGI #2
- For pressures up to 3,500 psi (241 bar)
- Lubricate up to 22 points per valve assembly
- Choice of SAE, NPSF, or BSPP inlet/outlet connections
- Fluoroelastomer o-ring sealing prevents leaks and reduces maintenance
- Individual valve outputs vary by a maximum ratio of 16:1
- Built-in check valves prevent lube re-entry and help keep lines full
- Modular, stackable design simplifies installation and adds flexibility
- Available in carbon steel with corrosion-resistant plating.
- Refer to the Graco ILE Buyer's Guide for stainless steel options.

Each assembly requires: **(A) valve sections** with working pistons (3 minimum), **(B) subplates** with outlet ports, **(C) inlet section**, and **(D) end sections**.

Twin piston sections are ported to create **separate outputs** for two lube points. **Single sections combine** the output from both ends of the piston and send it to a single lube point.

Field-installable **crossport or singling plates (E)** may be used to increase the flow to a single point or accommodate an odd number of lube points.

A **bypass section** is available to eliminate a piston section or provide for added lube points in the future.

NOTE: When bypass sections are used, the Divider Valve assembly must have a minimum of 3 working sections in addition to one or more bypass sections.

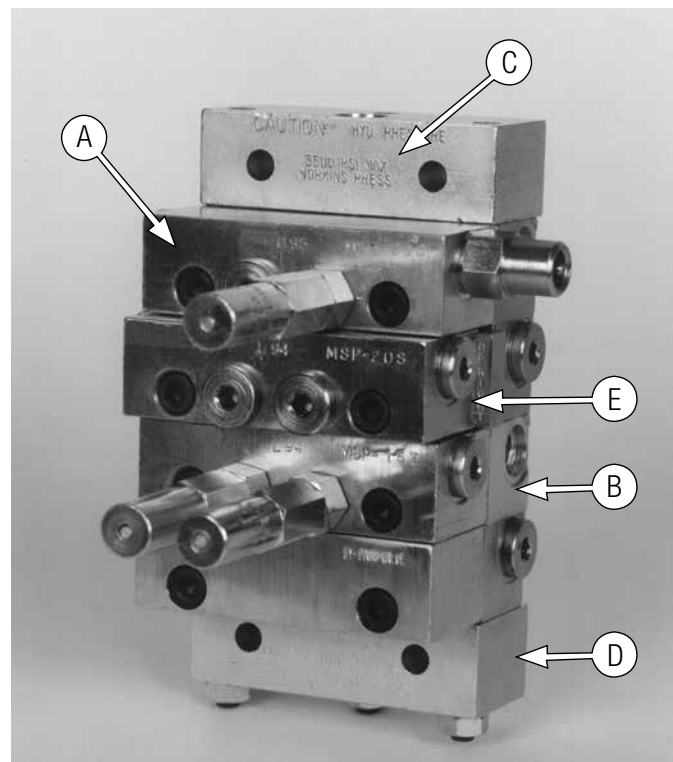

Designed with over 100 years of experience in centralized lubrication.

- Engineering certified to ISO 9001 Standards
- Modular design for maximum flexibility
- Install and maintain without disturbing lube lines

Quality Design

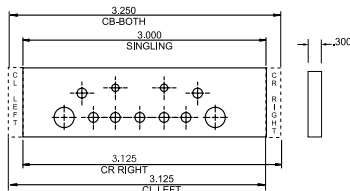
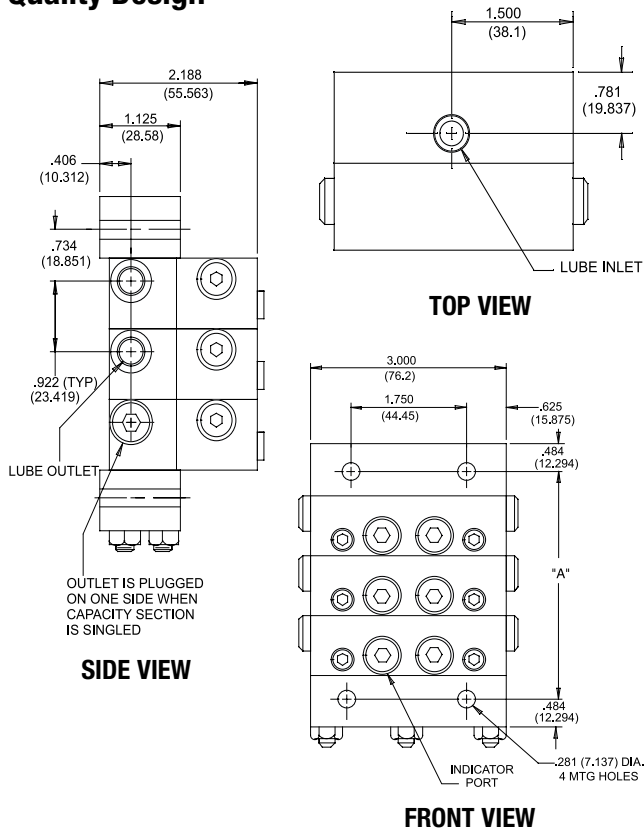

Style	Tab(s)
CR Right	Right
CL Left	Left
CB-Both	Right & Left
Singling	None

Qty of Sections	"A"
3	3.578 (90.881)
4	4.500 (114.30)
5	5.422 (137.718)
6	6.344 (161.138)
7	7.266 (184.556)
8	8.188 (207.975)

MSP DIVIDER SPECIFICATIONS	
Standard Material	Corrosion Protected Steel
Optional Material	Stainless Steel
O-Ring Seals	90 Durometer Fluoroelastomer (FKM)
Max Cycle Rate:	
w/Cycle Pin	60 CPM
w/out Cycle Pin, or w/Prox Cycle Sw	200 CPM
Pressure (max)	3500 psi (241 bar)
Temperature (max)	FKM Seals - 350°F (177°C)
Lubricant	Oil or Grease, up to NLGI #2
Zero Leak Inlet:	
Pressure (max)	1500 psi (104 bar)
Ambient Temperature (max)	140°F (60°C)
Lubricant (oil only)	Up to 5000 SUS Requires 25 micron (min) filtration
Electrical Characteristics	See page 7
Shunt/Shut-Off Inlet:	
Pressure (max)	3000 psi (207 bar) Intermittent supply pressure only
Ambient Temperature (max)	140°F (60°C)
Lubricant	Oil and Fluid Grease Filter oil through 25 micron filter and grease through a 100 mesh strainer
Electrical Characteristics	See page 7

DIVIDER VALVE ASSEMBLY	
Description	Net Weight lbs (kg)
3 section	5.9 (2.7)
4 section	7.3 (3.3)
5 section	8.7 (4.0)
6 section	10.2 (4.6)
7 section	11.6 (5.6)
8 section	13.0 (5.9)

TORQUE SPECIFICATIONS	
Tie Rod Nut	5-8 ft lbs
Valve Block Mtg. Screw	8-9 ft lbs*
Indicator Port Plug	8-9 ft lbs*
Inlet Bleed Screw	1-2 ft lbs
Piston Enclosure Plug	12-15 ft lbs*

*O-Ring sealed components

A wide variety of safeguards monitor and verify lube cycles

- Track valve-piston action
- Easily interfaced to system controller

Cycle Indicators

These mechanical and electrical units sense the divider valve piston's action for accurate control and monitoring of lube cycles.

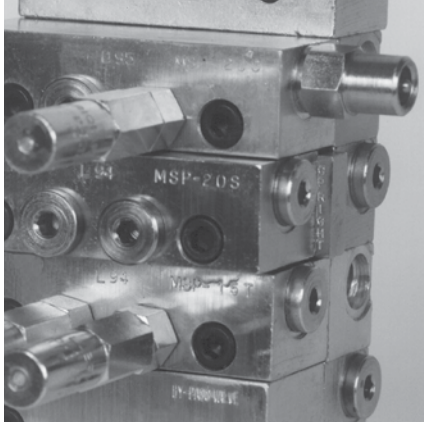

- **Cycle Indicator Pin:** Valve sections are available with a factory-installed indicator pin which moves in and out as lubricant passes through the valve.
- **Universal Cycle Counter:** Six-digit counter displays each complete cycle of the divider valve. Requires divider valve section with indicator pin (described above). Part number: **563444** (527-002-410).



- **Field-sensitive Proximity Switch:** A ceramic-magnet switch for grease or oil systems up to 200 cpm at pressure up to 3,500 psi (241 bar), accurately signals piston cycles, and is ideal for high-cycle applications. Part numbers: 3-pin with O-Ring, **557741** (527-003-251); 5-pin with O-Ring, **557746** (527-004-111).



- **Magnetic Visual Indicator:** Six steel balls in a clear sleeve follow a magnet which moves with the cycling piston, providing a clear visual indication of lube cycles. Part number: with O-Ring, **563251** (509-932-522).

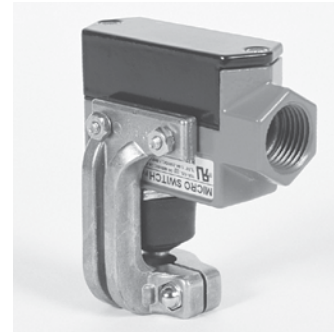

- **Cycle Indicator Switch (SPDT):** Used in conjunction with the cycle indicator pin at cycle rates not exceeding 60 cpm, it provides an electrical signal to the system controller which counts cycles to monitor and verify completion of the lube cycle. Part number: **563272** (510-599-000). A moisture-resistant switch, **563273** (510-599-200), is also available.

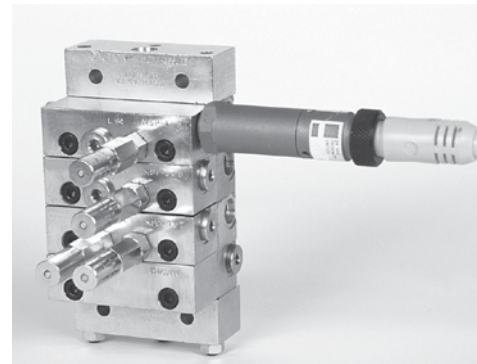

- **LED Field-sensitive Proximity Switch:** This 24 VDC device magnetically senses the movement of the piston, triggering the switch and illuminating the LED. Part numbers: 3-pin with O-Ring, **563478** (527-005-690); 5-pin with O-Ring, **563477** (527-005-670); Explosion proof with O-Ring; **563485** (527-006-060).
- **Connecting Cables:** Brad Harrison mating cables with either 3- or 5-pin connectors are available in 12-ft. (3.65 m) lengths for the F/S proximity switches and other devices. Refer to bulletin L15600 for complete listing of proximity cycle switches.

Choice of indicators offer automatic system protection and fault location.

- Immediate response to blockages
- Manual or automatic reset
- Continues to serve unaffected points

Performance Indicators

These vital safeguards react to excess lube pressure when points or lines become blocked. Installed in indicator ports on the working piston sections, they quickly identify the affected lines. Refer to bulletin L15401 for complete listing of available performance indicators.

- Automatic Relief-to-Atmosphere Indicator (O-Ring Seal): Spring-loaded piston unseats when blockage occurs, venting lubricant to atmosphere each time piston cycles. This allows system to lubricate unaffected points. When the blockage is cleared, the indicator resets automatically.
- Manual Reset Indicator with Memory (O-Ring Seal): System blockage triggers a spring-loaded piston to display an indicator. Since there is no relief, pressure backs up in the system and the system stops, allowing a controller to alarm. After correcting the problem, the indicator pin is reset manually.

ORDERING INFORMATION		
Relief Pressure	Part No.	Old Part No.
750 psi (51 bar)	563170	508-310-415
1000 psi (69 bar)	563171	508-310-425
1250 psi (86 bar)	563172	508-310-435
1500 psi (103 bar)	563173	508-310-445
2000 psi (138 bar)	563174	508-310-455
2500 psi (172 bar)	563175	508-310-465
3000 psi (207 bar)	563176	508-310-475

ORDERING INFORMATION		
Relief Pressure	Part No.	Old Part No.
250 psi (17 bar)	563252	509-932-590
500 psi (34 bar)	563253	509-932-600
750 psi (51 bar)	563254	509-932-610
1000 psi (69 bar)	563255	509-932-620
1500 psi (103 bar)	563256	509-932-630
2000 psi (138 bar)	563257	509-932-640
2500 psi (172 bar)	563258	509-932-650



Automatic Relief-to-Atmosphere Indicator



Manual Reset Indicator with Memory

Improve matchup of lube delivery and machine usage.

Special Inlet Sections

- Allow zoning of large systems served by single pump and reservoir
- Choice of inlet port activation: electric or pneumatic
- Simpler to install, add or remove points
- Choice of SAE, NPSF, or BSPP (ISO 1179) connection

These versatile inlets provide positive, series-progressive lubrication for extended lines and systems. You easily match lube delivery to machine usage, bypass machinery that's not currently in use, and get reliable start-up testing, monitoring, and fault detection.

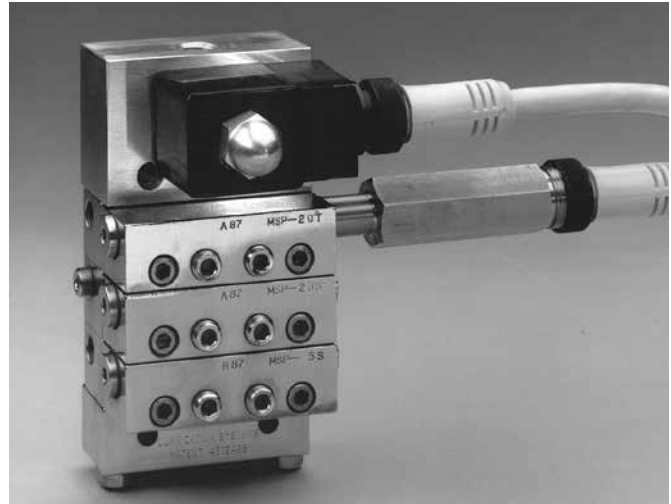

Zero-Leak Inlet Shut-Off

A two-way valve that can be used with either continuous or intermittent pressurized harder systems. Replaces a standard inlet section or mounts in-line with a remote manifold kit. Refer to bulletin L10104 for additional details. Refer to bulletin L10105 for modular zero-leak.

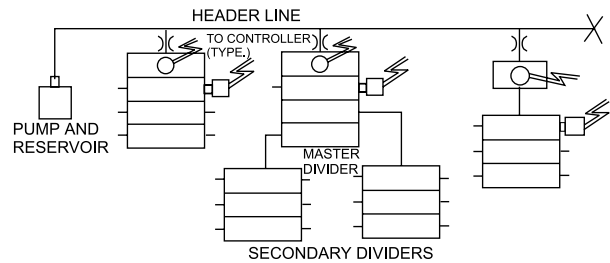

Shunt Inlet Section

A three-function valve, either electric or pneumatic: allows lubricant to enter divider valve, bypasses it to another divider valve, or diverts it back to tank. Replace standard inlet or mount in-line with remote manifold kit. See page 8 for part numbers.

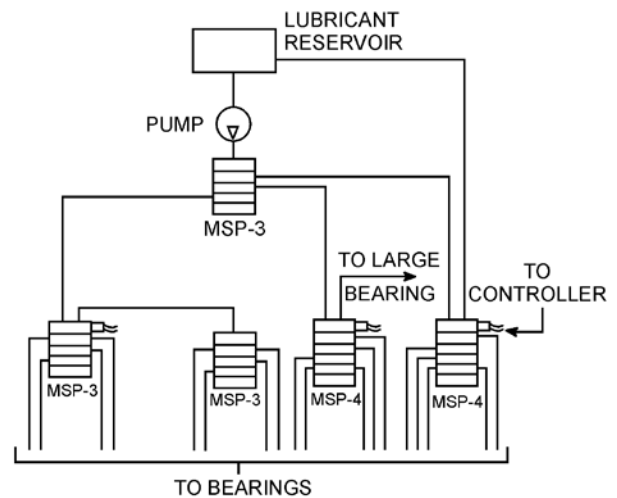
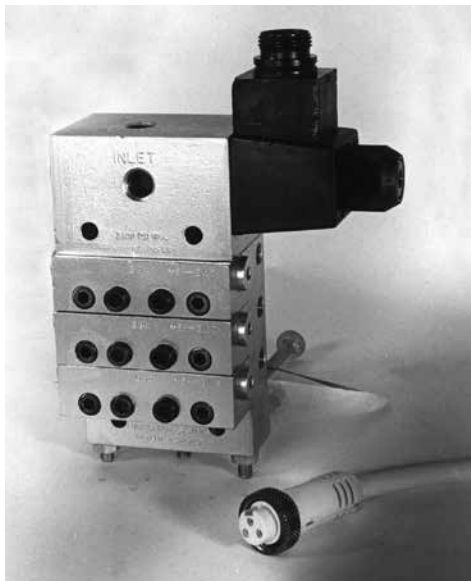

Zero-Leak Inlet Shut-Off Valve

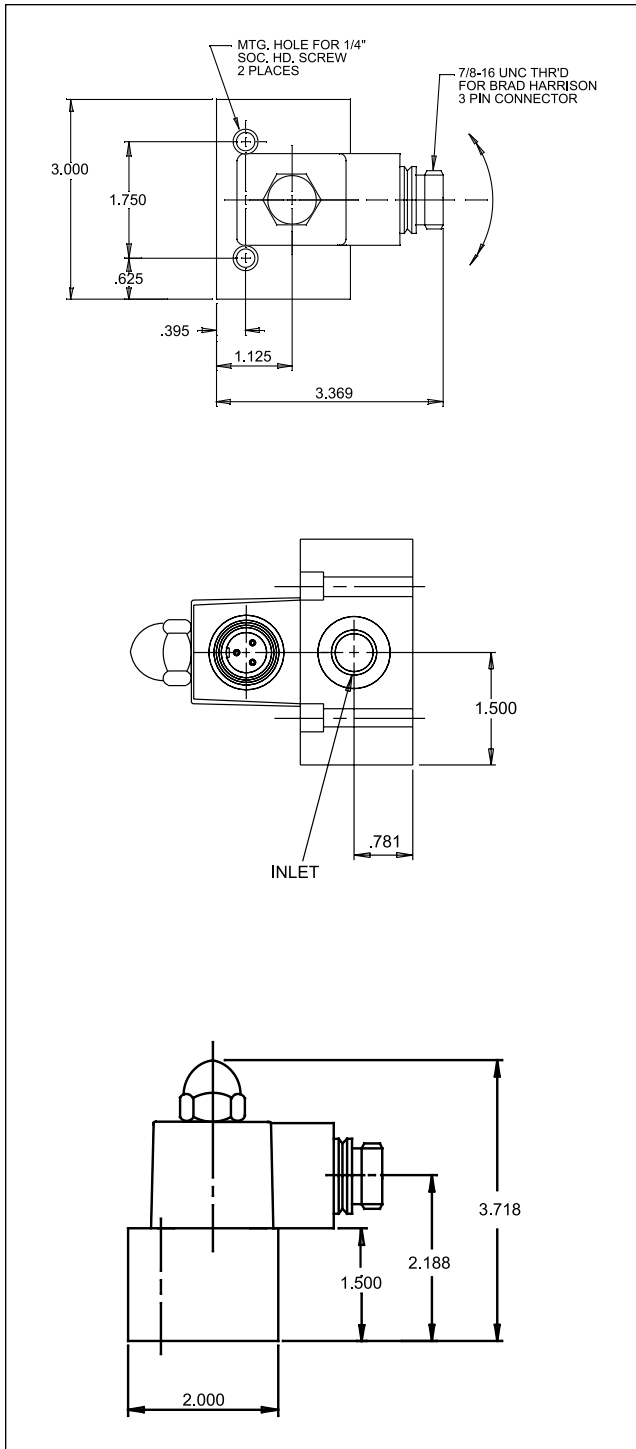

Zero-Leak Electrical Specifications:

115 VAC, 0.22 A In-Rush, 0.14 A Holding 24 VDC, 28 W

Shunt Inlet Option

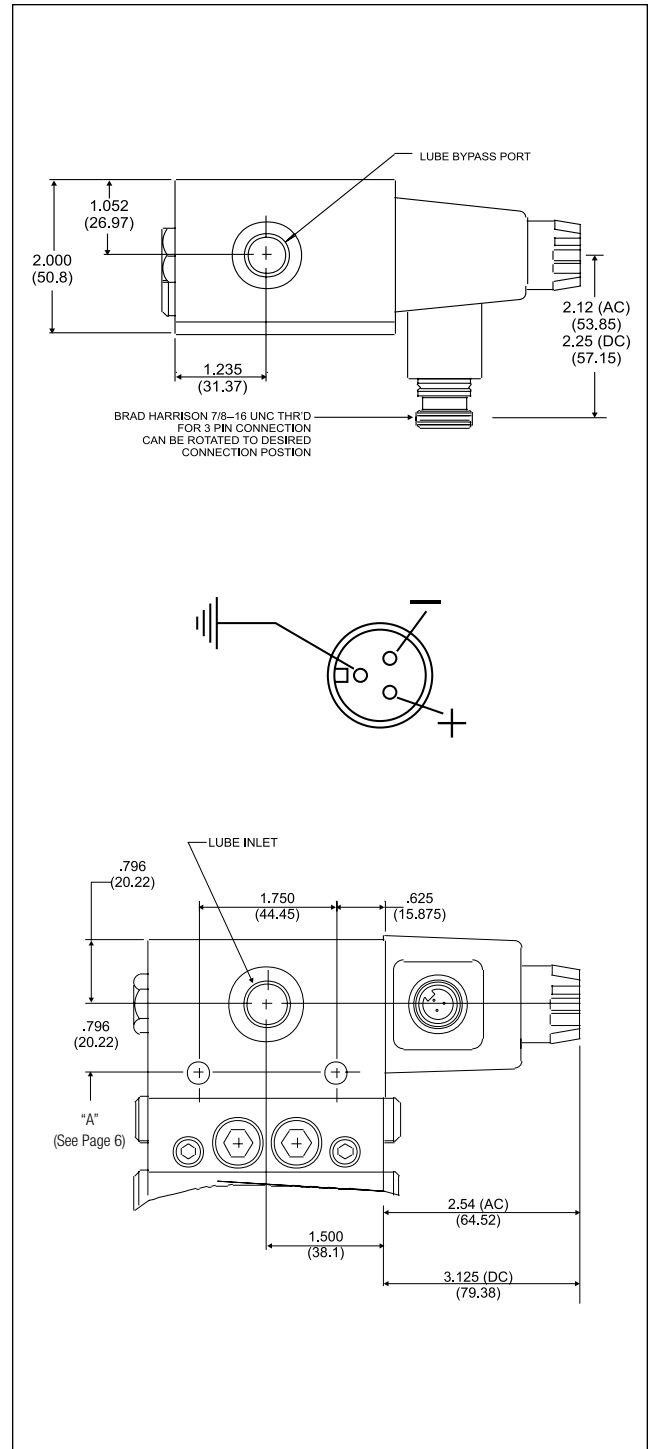

Shunt/Shut-Off Electrical Specifications:

115 VAC, 1.6 A In-Rush, 0.54 A Holding 24 VDC, 28 W

Solenoid mounted on right side: n.o. to divider, closed to bypass

Solenoid mounted on left side: n.c. to divider, open to bypass

You can easily configure the system to the need.

- Custom performance from stock modules
- Choice of Single or Twin outlets

Specifying Guide - MSP Divider Valve

Component Identification and Ordering Information
Zinc plated carbon steel

Item	Description T = Twin S = Single	Displacement in ³ (cm ³)	Fluoroelastomer Seal		w/Cycle Pin (RH) Fluoroelastomer Seal	
			Part no.	Old Part No.	Part No.	Old Part No.
1	Valve Sections					
	5T - .005	0.005 (0.082)	562720	106-100-175	-	-
	5S - .005	0.010 (0.164)	562711	106-100-015	-	-
	10T - .010	0.010 (0.164)	562721	106-100-185	-	-
	10S - .010	0.020 (0.328)	562712	106-100-025	-	-
	15T - .015	0.015 (0.246)	562722	106-100-195	-	-
	15S - .015	0.030 (0.492)	562713	106-100-035	-	-
	20T - .020	0.020 (0.328)	562723	106-100-205	562739	106-100-935
	20S - .020	0.040 (0.656)	562714	106-100-045	562729	106-100-735
	25T - .025	0.025 (0.410)	562724	106-100-215	562740	106-100-945
	25S - .025	0.050 (0.820)	562715	106-100-055	562730	106-100-745
	30T - .030	0.030 (0.492)	562725	106-100-225	562741	106-100-955
	30S - .030	0.060 (0.983)	562716	106-100-065	562731	106-100-755
	35T - .035	0.035 (0.574)	562726	106-100-235	562742	106-100-965
	35S - .035	0.070 (1.148)	562717	106-100-075	562732	106-100-765
	40T - .040	0.040 (0.656)	562727	106-100-245	562743	106-100-975
	40S - .040	0.080 (1.311)	562718	106-100-085	562733	106-100-775

	Part No.	Old Part No.
Cycle Indicator Pin Repair Kit	563929	560-002-055

Item	Description	Part No.	Old Part No.
2	Subplate		
	1/8-27 NPSF	563425	527-000-311
	7/16-20 SAE	563451	527-003-550
	1/8-28 BSPP (ISO 1179)	563447	527-003-140
3	Inlet		
	1/4-18 NPSF	560919	527-001-800
	7/16-20 SAE	560943	527-003-540
	1/4-19 BSPP (ISO 1179)	560936	527-003-130
	Inlet w/Bleed		
	1/4-18 NPSF	563421	527-000-322
	7/16-20 SAE	563422	527-000-325
4	Standard End Section	563424	527-001-900
	End (SPP)*	563279	510-770-332
5	Crossport Plate		
	Right	563469	527-005-320
	Left	563470	527-005-330
	Both	563471	527-005-340
6	Singling Plate	563472	527-005-350
7	Bypass Block	562660	106-000-010

*Use Leakproof Grease Nipple, p/n 555888 (straight) or 556429 (90°), sold separately.

Item	Description	Part No.	Old Part No.
8	Tie Rod (3 required)		
	3 Section	557731	527-001-930
	4 Section	557732	527-001-940
	5 Section	557733	527-001-950
	6 Section	557734	527-001-960
	7 Section	557735	527-001-970
	8 Section	557736	527-001-980
9	Tie Rod Nut Only (3 required)	556371	410-440-010
10	Valve Block Mounting Screws	122712	-
11	Piston Enclosure Plug	557716	527-000-232
11+12	Piston Enclosure Plug and O-Ring, Fluoroelastomer	567251	412-700-541
12	Piston Enclosure O-Ring, Fluoroelastomer	556570	422-240-040
13	Indicator Port Plug	557776	527-300-840
13+14	Indicator Port Plug and O-Ring, Fluoroelastomer	16U217	-
14	Indicator Port Plug O-Ring, Fluoroelastomer	556569	422-240-030
15	MSP (90 Duro) Fluoroelastomer O-Ring	122276	-
16	Valve Block Mounting Screw for Crossport/Singling Plate	556514	419-140-080
17	Outlet Check Ball	556327	401-030-020
18	Outlet Check Spring	557508	510-682-003
19	Outlet Port Plugs for Single and Crossported Sections		
	1/8" Pipe Plug, NPT	557349	503-485-000
	Plug and O-Ring, SAE	567251	412-700-541
	Plug and O-Ring, BSPP	558799	412-700-404

Special Inlets			
Valve State	Description	Part No.	Old Part No.
N.C.	Zero-Leak, 115 VAC, 3-Pin Brad Harrison Connector		
	1/4-18 NPSF	563460	527-004-320
	9/16-18 SAE	563468	527-005-200
	Replacement Coil	557226	492-120-206
N.C.	Zero-Leak, 24 VDC, 3-Pin Brad Harrison Connector		
	1/4-18 NPSF	563464	527-004-870
	9/16-18 SAE	563467	527-005-180
	1/4 BSPP (ISO 1179)	563082	463-920-720
	Replacement Coil	557225	492-120-205
	Zero-Leak, No Coil (order separately)	563462	527-004-770
N.O.	Shunt/Shut-Off, 115 VAC, 3-Pin Brad Harrison Connector		
	1/4-18 NPSF	563452	527-003-660
	9/16-18 SAE	560953	527-004-790
	1/4-18 NPSF	563453	527-003-670
	9/16-18 SAE	563463	527-004-800
	Replacement Coil	557214	492-120-128
N.O.	Shunt/Shut-Off, 24 VDC, 3-Pin Brad Harrison Connector		
	1/4-18 NPSF	563454	527-003-680
	9/16-18 SAE	563482	527-005-780
	1/4 BSPP (ISO 1179)	563493	527-007-090
	1/4-18 NPSF	563455	527-003-690
	9/16-18 SAE	563483	527-005-785
	1/4 BSPP (ISO 1179)	563494	527-007-100
	Replacement Solenoid	557215	492-120-130
	Shunt/Shut-Off Pneumatic Operator	563456	527-003-730
	Pneumatic Shunt Repair Kit	24E702	-
Remote Manifold kit - Zero-Leak and Shunt/Shut-Off			
	1/4-18 NPSF	563461	527-004-360
	9/16-18 SAE	-	527-005-400

Modular design for full flexibility

- One valve assembly serves up to 16 points (or more)
- O-Ring sealing throughout prevents leakage
- Built-in check valves prevent lube re-entry and help keep lines full

MSP Divider Valve

Part List Schematic

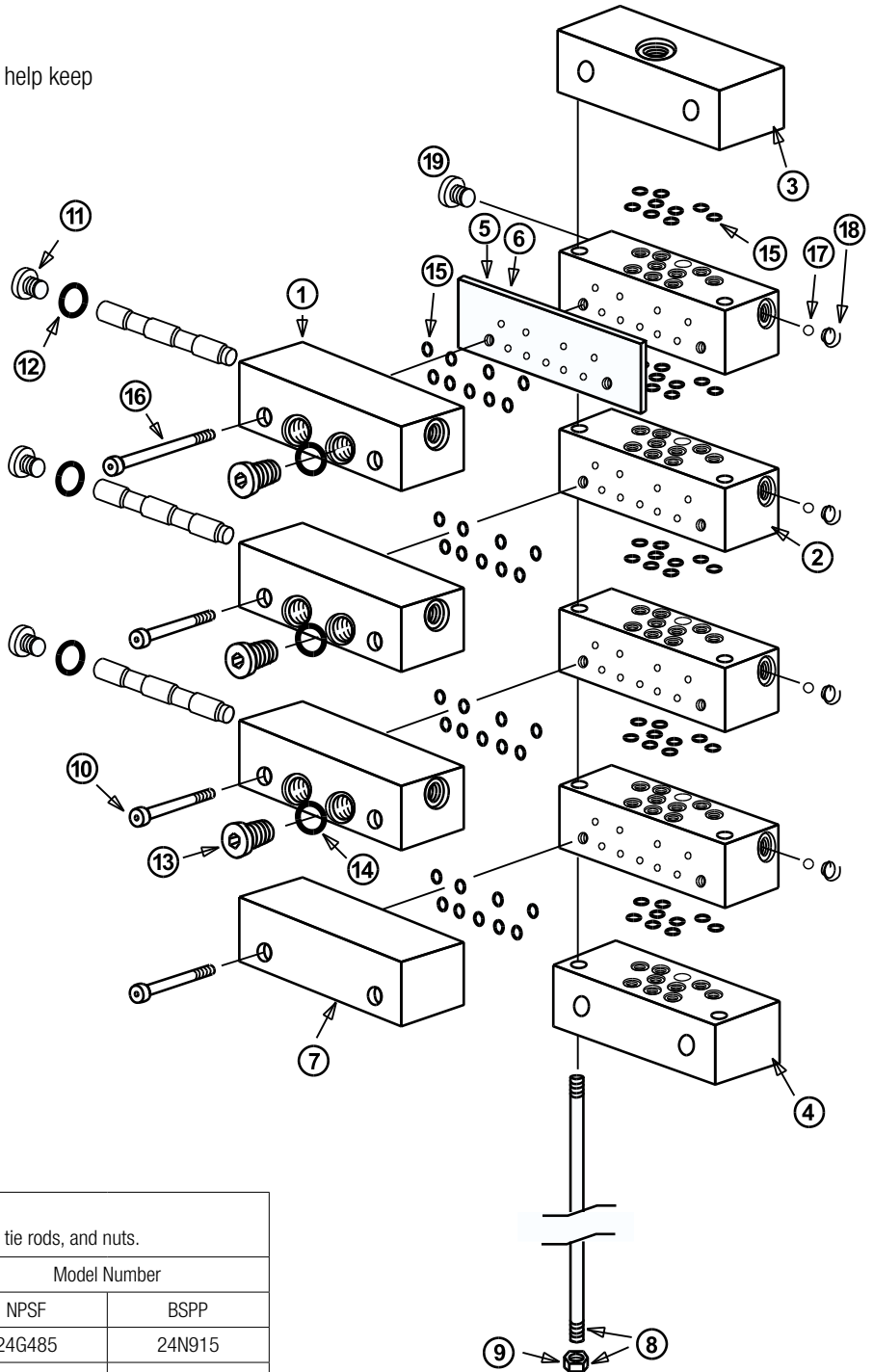

Pre-Configured MSP Base Plate Assemblies Includes inlets, intermediate base plate sections, end section, tie rods, and nuts.				
Item	Maximum Number of Outlets	Number of Valve Sections	Model Number	
			NPSF	BSPP
2/3/4/8/9	6	3	24G485	24N915
	8	4	24G486	24N916
	10	5	24G487	24N917
	12	6	24G488	24N918
	14	7	24G489	24N919
	16	8	24G490	24N920

Legacy Ordering Menu – Provided for reference only

	XXX	-	XXX	-	XX	-	X	-	X	-	XX	-	X	-	XX
SERIES OF FEEDER															
MSP - STANDARD INDUSTRIAL TO 3500 PSI MSV - SUPERSEDED BY MSP															
INLET/OUTLET PORT TYPES															
SAE - STRAIGHT THREAD O-Ring SEAL NPT - NPSF PIPE THREAD BSP - BRITISH PARALLEL PIPE O-Ring SEAL (ISO 1179)															
INLET SECTION OPTIONS															
MS - STANDARD INLET MH - INLET W/BLEED SCREWS SH - INLET W/SHUNT/SHUT-OFF (115 VAC) SD - INLET W/SHUNT/SHUT-OFF (24 VDC) ZL - ZERO LEAK SHUT-OFF INLET (115 VAC) ZF - ZERO LEAK SHUT-OFF INLET (24 VDC)															
DIVIDER VALVE ACCESSORY OPTIONS*															
P - ASSEMBLY OF PERFORMANCE INDICATORS IN ALL WORKING OUTLETS B - ASSEMBLY OF PERFORMANCE INDICATORS AND CHECK VALVES IN ALL WORKING OUTLETS C - EXTERNAL CHECK VALVES IN ALL WORKING OUTLETS E - SPP END SECTION W/PLUG IN 1/8-27 NPSF PORT FOR MANUAL LUBE FITTING - 563279 - (510-770-332)															
*Options P, B, and C indicated additional accessories; those accessories were to be specified as a separate line item.															
NUMBER OF SECTIONS															
3 - THREE 6 - SIX 4 - FOUR 7 - SEVEN 5 - FIVE 8 - EIGHT															
VALVE CAPACITY MS VALVE BLOCK															
BP - BYPASS 05 - .005 cu.in. (.082 cm ³) 10 - .010 cu.in. (.164 cm ³) 15 - .015 cu.in. (.246 cm ³) 20 - .020 cu.in. (.328 cm ³) 25 - .025 cu.in. (.410 cm ³) 30 - .030 cu.in. (.492 cm ³) 35 - .035 cu.in. (.574 cm ³) 40 - .040 cu.in. (.656 cm ³)															
TYPE OF VALVE BLOCK															
T - TWIN VALVE S - SINGLE VALVE - RH OUTLET L - SINGLE VALVE - LH OUTLET B - TWIN VALE W/CYCLE PIN RIGHT C - SINGLE VALVE W/CYCLE PIN RIGHT - RH OUTLET D - SINGLE VALVE W/CYCLE PIN RIGHT - LH OUTLET H - TWIN VALVE W/CYCLE PIN LEFT J - SINGLE VALVE W/CYCLE PIN LEFT - RH OUTLET K - SINGLE VALVE W/CYCLE PIN LEFT - LH OUTLET															
CROSSPORTING OPTION															
CR - RIGHT HAND SIDE CL - LEFT HAND SIDE CB - BOTH SIDES															

Notes

1. Right/Left Hand determined when viewing front of divider valve assembly. (Divider valve assembly placed on flat surface with inlet at top.)
2. Valves are specified starting from inlet section.
3. When valve is crossported, its outlet is plugged and output is diverted to next valve away from inlet.
4. Last valve in divider assembly, farthest from inlet, cannot be crossported.
5. Single valve can be crossported on one side only.
6. When valve is a single, only one outlet in its subplate can be used, other outlet must be plugged.
7. Cycle pins are available on MSP (20, 25, 30, 35, and 40) valves only.
8. All divider valve assemblies must have a minimum of 3 working valves.
9. Bypass block cannot be supplied on divider valve with 3 subplates. Bypass block is not a working valve.
10. Divider systems should be limited to first and second stages only. Third staging is not recommended. Refer to Trabon **Bulletins L20101, L20105, and L20115** for further information on system design.

Legacy Ordering Example

5-section MSP Divider Valve Assembly, standard seals, SAE ports and performance indicators in each working outlet. Consisting of:

- 1 - .030 Twin Valve with Cycle Pin Right Side
- 1 - .040 Single Valve - Crossport Right Side
- 1 - .040 Single Valve - Right Hand Outlet
- 1 - .020 Twin Valve
- 1 - Bypass Block

Ordering Code - MSP-SAE-MS-P-5-30B-40SCR-40S-20T-BP

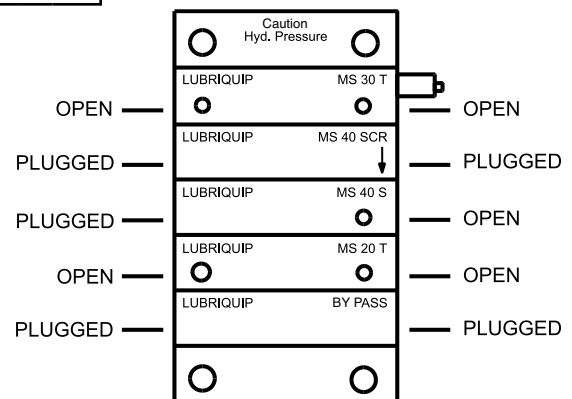

Graco® has applied automatic lubrication technology to a world of needs – including yours!



Graco systems require minimum attention. Filling the reservoir and periodic inspections are the only routine maintenance required.



Lube delivery to machines in motion is often superior to static lubrication. Oil and grease are forced into the load area to coat wear points.



Graco's automated systems deliver lubricant to vital mechanisms, prolonging equipment life and reducing downtime.

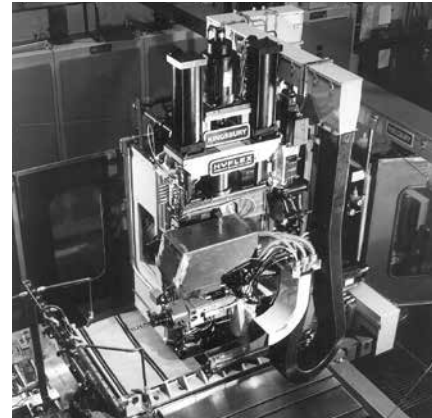

Automated systems improve safety. Maintenance personnel do not have to lubricate dangerous machinery. Operators have less exposure to oil and lubricants on equipment and floor.

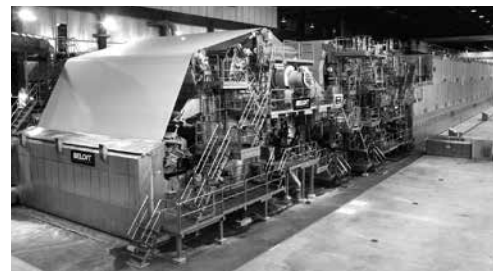

Graco's precise lubricant delivery eliminates lubricant waste, product contamination and heat buildup from excessive viscous shear.



Surges, vibrations, and other erratic operations are reduced with automatic lube systems. This minimizes risk of damage to equipment, products and personnel.



Your solution is at hand.



Our years of engineering innovative lubrication technology, plus our worldwide network of distributors means that the components you need are probably in stock right now. This inventory of proven components allows distributors and factory engineers to design a truly customized system using economical on-the-shelf parts.

New or upgrade, Graco has the applied technology.

Whether you are considering new equipment or upgrading an existing system, count on Graco for the applied lubrication technology to meet your need with a minimum of hassle and investment. Call on our unparalleled customer support for fast, efficient design, installation, maintenance and troubleshooting assistance, or to get the name of your nearest full-line, factory-trained distributor.

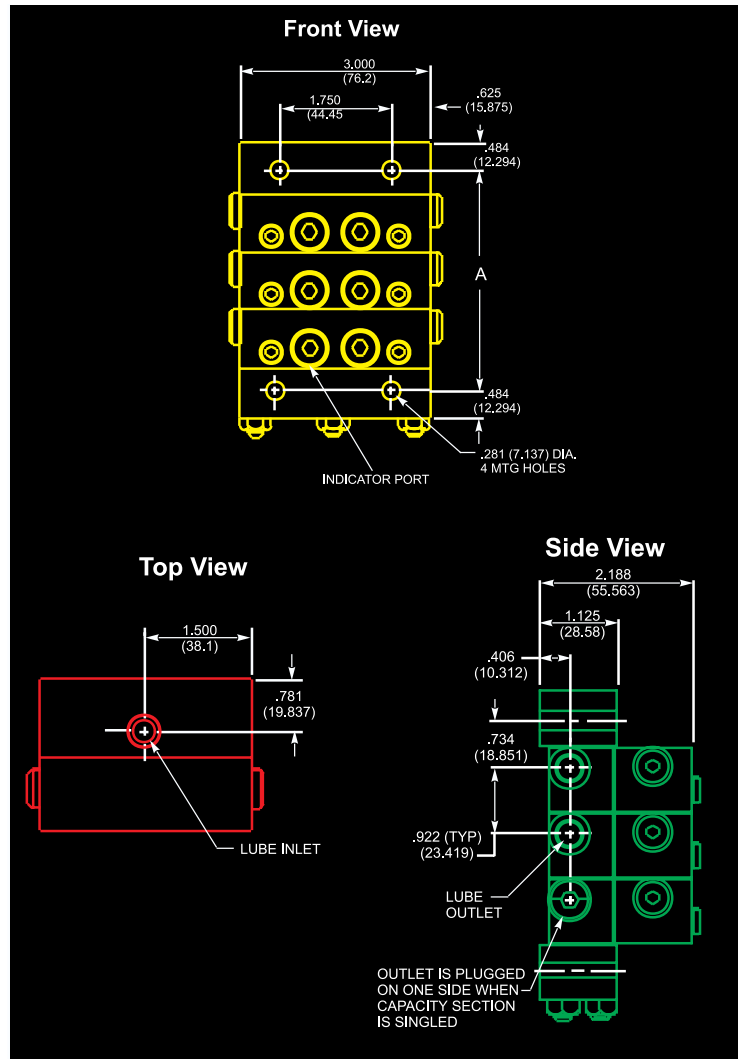

Contact us today!

To receive product information or talk with a Graco representative, call 800-533-9655 or visit us online at www.graco.com.

