

Servo drives CMMT-AS

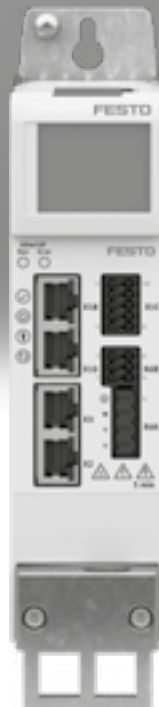

Festo core product range
Covers 80% of your automation tasks

Worldwide:
Superb:
Easy:

Always in stock
Festo quality at an attractive price
Simplified procurement and warehousing

★ Generally ready for dispatch from the factory within 24 hours
In stock at 13 Service Centres worldwide
More than 2200 products

★ Generally ready for dispatch from the factory within 5 days
Assembled for you at 4 Service Centres worldwide
Up to 6×10^{12} variants per product family

Just look
for the
star!

Key features

At a glance

- Universal servo drive for PM-synchronous servo motors up to 6000 W continuous power
- Supports the motor series EMMT-AS, EMME-AS, EMMB-AS and EMMS-AS as well as third-party motors
- Integrated single-phase/three-phase mains connection 230/400 V AC, mains filter and braking resistor, connection option for external braking resistor
- Precise torque, speed and position control
- Motion from point-to-point to interpolated motion
- Comprehensively integrated protective functions for the servo drive, motor and axis with automatic motor shut-down/quick stop
- Bus protocols

- Configuration:
 - Automatically with the "Festo Automation Suite" as well as auto-tuning
 - Directly via fieldbus and PLC
 - Data backup concept via PLC or operator unit CDSB
- Supports digital absolute encoders (EnDat, HIPERFACE, Nikon-A) in the motor as well as incremental (A/B, Sin/Cos) displacement encoders on the axis
- Integrated safety functions:
 - Safe torque off (STO) up to SIL3/Cat. 4 PL e
 - Safe stop 1 (SS1) when using a suitable external safety relay unit and suitable circuit for the servo drive
 - Safe brake control (SBC) up to SIL3/Cat. 3 PL e
 - Diagnostic outputs STA and SBA for feedback of the active safety function



- Modbus TCP is available as an additional protocol for all EtherNet/IP devices
- Prepared device description files and function blocks for integration in PLC systems

The technology in detail

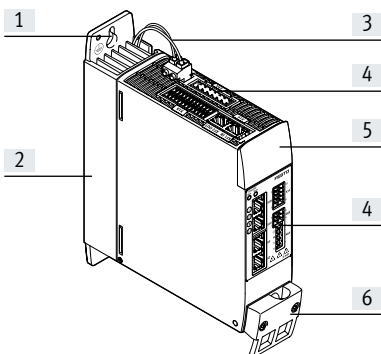

- [1] Elongated hole for mounting the servo drive on the control cabinet back wall
- [2] Cooling element for dissipating heat. The internal braking resistor is housed in the cooling element
- [3] Connection for braking resistor
- [4] Connections
- [5] Blanking plate (optionally with plug-on operator unit CDSB → page 14)
- [6] Shield clamp and strain relief

PositioningDrives

Configuring electromechanical drives



Create the optimum drive package quickly and reliably. PositioningDrives calculates suitable combinations of electric axis, electric motor and servo drive using just a few application details. You can sort the results according to your specifications and obtain all the relevant data including the bill of materials and documentation for the selected combination. This avoids design errors and results in significantly improved energy efficiency for the system.

Key features

Library for EPLAN

→ www.festo.de/eplan

EPLAN macros for fast and reliable planning of electrical projects in combination with servo drives, motors and cables. This enables a high level of planning reliability and standardisation of documentation without the need to create symbols, graphics and master data.

Festo Automation Suite

Parameterisation and programming software for electronic devices from Festo

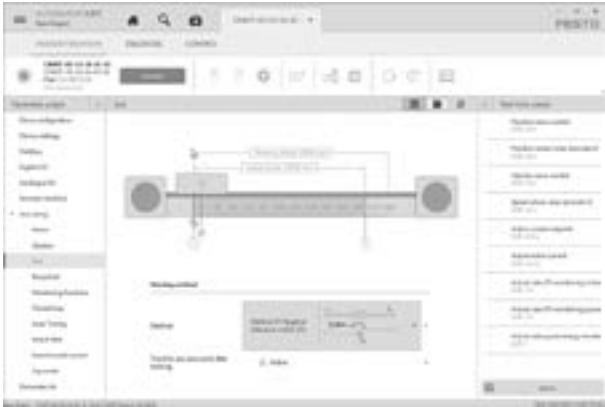

- Parameterisation, programming and commissioning in a clear and user-friendly interface
- Optimum support for complex processes thanks to guided wizards (e.g. for commissioning, drive configuration, etc.)
- Fast access to the required documents and additional information
- Easy integration of electric drives in the controller programming

System overview

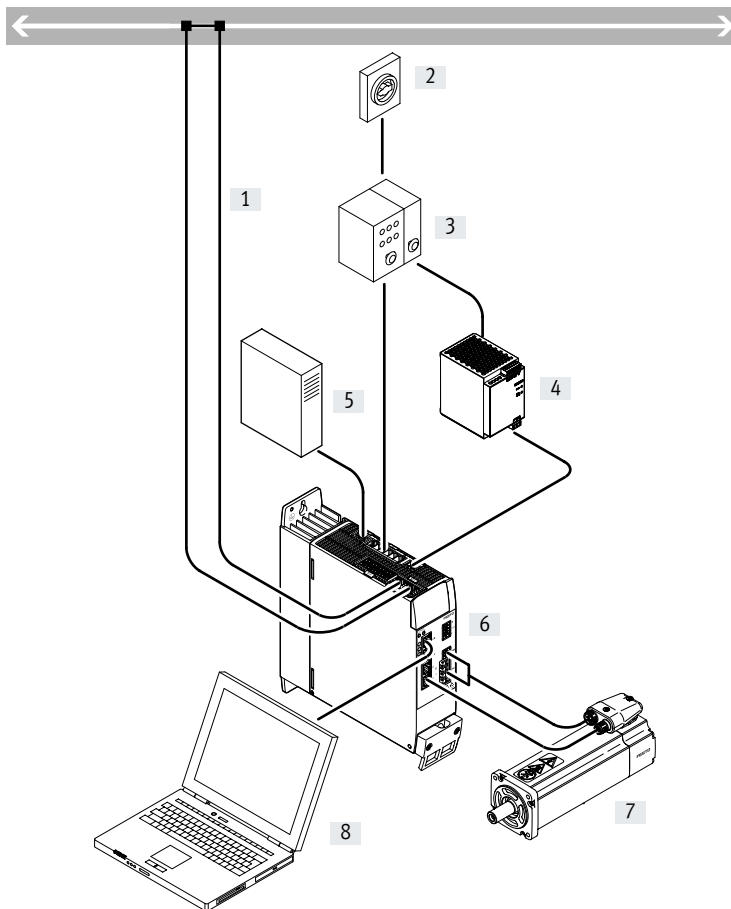

- [1] Bus/network
- [2] Main switch
- [3] Circuit breaker/fuses
- [4] Fixed power supply for logic voltage supply 24 V DC (PELV)
- [5] External braking resistor (optional)
- [6] Servo drive CMMT-AS
- [7] Servo motor
- [8] PC with Ethernet connection for parameterisation

Type codes

001	Series	
CMMT	Motor controller	

002	Motor type	
AS	AC synchronous	

003	Nominal current	
C2	2 A	
C3	3 A	
C4	4 A	
C5	5 A	
C7	7 A	
C12	12 A	

004	Nominal input voltage	
3A	230 V AC/50-60Hz	
11A	400 V AC	

005	Number of phases	
	Single-phase	
P3	Three-phase	

006	Bus protocol/activation	
EC	EtherCAT®	
EP	EtherNet/IP	
PN	Profinet	

007	Safety function	
S1	Standard safety	

Data sheet

Bus protocols



EtherNet/IP



General technical data		C2-3A...	C4-3A...	C2-11A...	C3-11A...	C5-11A...	C7-11A...	C12-11A...
CMMT-AS-								
Type of mounting	Mounting plate, screwed in							
Indicators	Green/yellow/red LED or operator unit CDSB with plain-text message							
Controller mode of operation	<ul style="list-style-type: none"> • Cascade controller • P position controller • PI speed controller • PI current regulator for F or M • Profile operation with record and direct mode • Interpolated mode via fieldbus • Homing/setup mode/auto-tuning 							
Operating mode	<ul style="list-style-type: none"> • Field-oriented control, position resolution 24-bit/rev. • Sampling rate 16 kHz • PWM with 8 or 16 kHz, vector modulation with third harmonic (16 kHz only with CMMT-AS-C2-3A and CMMT-AS-C4-3A) • Real-time data acquisition: <ul style="list-style-type: none"> – 2x input position capture – 2x output position trigger – 2x position encoder input – 1x SYNC interface for encoder emulation or encoder input 							
Mounting position	Vertical							
Product weight	[g]	1300	1400	2100	2100	2200	4100	4100

Bus protocols		EtherCAT	PROFINET RT/IRT	EtherNet/IP	Modbus TCP
Interface					
Function	Bus connection incoming/outgoing				
Process interfacing	Interpolated mode CSP	AC1: adjustable-speed drives	Adjustable-speed drives	Adjustable-speed drives	Adjustable-speed drives
	Interpolated mode CSV	AC3: drives with positioning function	Drives with positioning function	Drives with positioning function	Drives with positioning function
	Interpolated mode CST	AC4: synchronous servo application			
	Point-to-point mode PP				
	Point-to-point mode PV				
	Point-to-point mode PT				
	Homing mode HM				
	Record table with 128 entries				
Communication profile	CiA402	PROFIdrive	DriveProfile	DriveProfile	
	CoE (CANopen over EtherCAT)	PROFIenergy			
	EoE (Ethernet over EtherCAT)				
Max. fieldbus transmission rate	[Mbps]	100			
Connection type	2x bushing				
Connection technology	RJ45				

Data sheet

Electrical data		C2-3A...	C4-3A...	C2-11A...	C3-11A...	C5-11A...	C7-11A...	C12-11A...
Output connection data								
Output voltage range	[V AC]	3x (0 – Input)						
Nominal current per phase	[A _{eff}]	2	4	1.7	2.5	5	7	12
Peak current per phase	[A _{eff}]	6	12	5.1	7.5	15	21	36
Max. peak current duration (at fs ≥ 5 Hz)	[s]	2						
Nominal power	[W]	350	700	800	1200	2500	4000	6000
Peak power	[W]	1000	2000	2400	3600	7500	12000	18000
Output frequency	[Hz]	0 ... 599						
Max. motor cable length ¹⁾	[m]	25/25			50/100		25/100	
Load voltage AC								
Nominal operating voltage phases		Single-phase			Three-phase			
Input voltage range	[V AC]	100 –20% ... 230 +15%			200 –10% ... 480 +10%			
Nominal operating voltage	[V AC]	230			400			
Nominal current	[A _{eff}]	2.8	5.6	2	3	6	9	15
Peak current		8.4	16.8	6	9	18	27	45
Mains frequency	[Hz]	48 ... 62						
System voltage to EN 61800-5-1	[V]	300						
Max. short circuit current rating of the mains	[kA]	100			10			
Mains types of system earthing		TN, TT, IT			TN, IT			
Mains filter		Integrated						
Load voltage DC								
Input voltage range	[V DC]	80 ... 360			80 ... 700			
Max. DC link voltage	[V DC]	395			800			
Nominal current								
at 320 V DC	[A]	1.3	2.6	–	–	–	–	–
at 560 V DC	[A]	–	–	1.5	2.3	4.7	7.5	11.2
Logic supply								
Nominal voltage	[V DC]	24 ±20%						
Max. current consumption	[A]	0.5/2.3 ²⁾				0.5/2.5 ²⁾		

- 1) Without/with external mains filter
- 2) Max. current at full expansion, with two position encoders, brake output and all I/Os with max. specified loads connected

Braking resistor		C2-3A...	C4-3A...	C2-11A...	C3-11A...	C5-11A...	C7-11A...	C12-11A...
Integrated								
Resistance	[Ω]	100		130		47		
Pulse power	[kW]	1.6		5		13.6		
Pulse energy	[Ws]	230		850		1200		
Nominal power	[W]	23		48		48		58
External								
Resistance	[Ω]	100 ... 160	67 ... 100	130 ... 250	130 ... 250	80 ... 130	60 ... 85	40 ... 60
Max. continuous power	[W]	180	350	400	600	1200	1500	3000

Motor auxiliary connections		C2-3A...	C4-3A...	C2-11A...	C3-11A...	C5-11A...	C7-11A...	C12-11A...
Motor temperature monitoring								
Digital		Connection for temperature switch (PTC, N/C contact or N/O contact)						
Analogue		Connection for analogue temperature sensor (KTY81 ... 84, NTC, Pt1000)						
Output for holding brake								
Design		High-side switch; 24 V; monitored internally						
Output current	[A]	1.0				1.3	1.5	
Output for 2nd brake								
Design		High-side switch; 24 V; monitored internally						
Output current	[A]	0.1						

Data sheet

Interfaces		
Ethernet		
Function	Parameterisation and commissioning	
Protocol	DHCP	
	FTP	
	TCP/IP	
Position encoders		
Function of position encoder 1	ENDAT 2.1 encoder	
	ENDAT 2.2 encoder	
	HIPERFACE encoder	
	Incremental encoder	
	SIN/COS encoder	
Function of position encoder 2	Nikon-A	
	Incremental encoder	
Synchronisation		
Function	Encoder emulation A/B/Z	
	Encoder input A/B/Z	
Encoder output, characteristics	1 MHz maximum output frequency	
	Resolution up to 16384 ppr	
Encoder input, characteristics	1 MHz maximum input frequency	
	Resolution up to 16384 ppr	
Input/output		
Digital inputs		
Number	10 ... 12 (depending on device design)	
Number of high-speed	2	
Time resolution of high-speed	[μ s]	1
Switching logic	PNP	
Characteristics	Not galvanically isolated	
	Freely configurable in some cases	
	Safety inputs in some cases	
Specification	Based on IEC 61131-2, type 3	
Operating range	[V]	0 ... 30
Digital outputs		
Number	4 ... 6 (depending on device design)	
Number of high-speed	2	
Time resolution of high-speed	[μ s]	1
Switching logic	PNP	
Characteristics	Not galvanically isolated	
	Freely configurable in some cases	
Max. current	[mA]	20
Analogue setpoint inputs		
Number	1	
Characteristics	Differential input	
	Configurable for current/force, rotational speed and position	
Operating range	[V]	± 10
Impedance	[k Ω]	70
Floating switching outputs		
Number	1	
Max. current	[mA]	50

Data sheet

Safety characteristics		
Safety function to EN 61800-5-2		Safe torque off (STO)
		Safe stop 1 (SS1)
		Safe brake control (SBC)
Performance Level (PL) to EN ISO 13849-1		
Safe torque off (STO)		Category 4, Performance Level e
Safe brake control (SBC)		Category 3, Performance Level e
Safety integrity level (SIL) to EN 62061 and EN 61508		
Safe torque off (STO)		SIL 3/SILCL 3
Safe brake control (SBC)		SIL 3/SILCL 3
Certificate issuing authority and no.		TÜV Rheinland (German Technical Control Board) 01/205/5640.00/18
Proof test interval		
Safe torque off (STO)		Up to 20a
Safe brake control (SBC)		24 h
Diagnostic coverage	[%]	Up to 97
Safe failure fraction (SFF)	[%]	Up to 99
Hardware fault tolerance		1
Operating and environmental conditions		
Degree of protection		IP20
Ambient temperature ¹⁾	[°C]	0 ... +50
Storage temperature	[°C]	-25 ... +55
Relative humidity	[%]	5 ... 90 (non-condensing)
Protection class		I
Overvoltage category		III
Pollution degree		2
Surge resistance	[kV]	6
Max. installation height ²⁾	[m]	2000
Shock and vibration resistance		To EN 61800-2 and EN 61800-5-1
CE marking (see declaration of conformity)		To EU EMC Directive ³⁾
		To EU Machinery Directive
		To EU Low Voltage Directive
		To EU RoHS Directive
KC marking		KC EMC
Certification		c UL us listed (OL)
		RCM compliance mark
Note on materials		Contains paint-wetting impairment substances
		RoHS-compliant

1) Above 40°C power is reduced by 3% per K.

2) Above 1000 m power is reduced by 1% per 100 m.

3) For information about the area of use, see the EC declaration of conformity at: www.festo.com/sp → Certificates.

If the devices are subject to usage restrictions in residential, commercial or light-industrial environments, further measures for the reduction of the emitted interference may be necessary.

Data sheet

View of servo drives

Front view

- [1] PE connection, housing
- [2] [X5] Connection for operator unit (behind blanking plate)
- [3] [X18] Standard Ethernet
- [4] [X10] Device synchronisation
- [5] [X3] Position encoder 2
- [6] [X2] Position encoder 1
- [7] [X9B] Connection for braking resistor
- [8] [X1C] Inputs/outputs for the axis
- [9] [X6B] Motor auxiliary connection
- [10] [X6A] Motor phase connection
- [11] Shield clamp and strain relief

CMMT-AS-...-3A

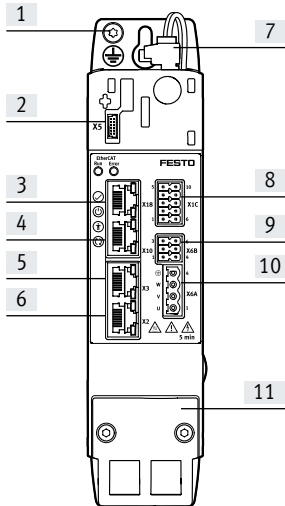

CMMT-AS-C2/C3/C5-...-11A

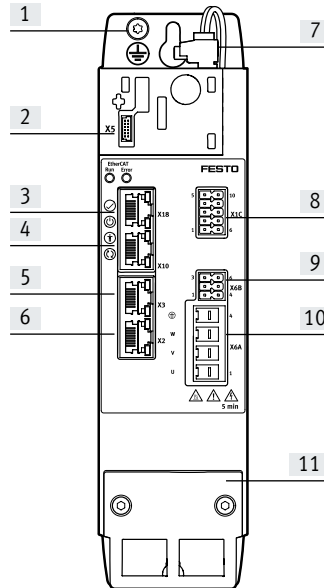

CMMT-AS-C7/C12-...-11A

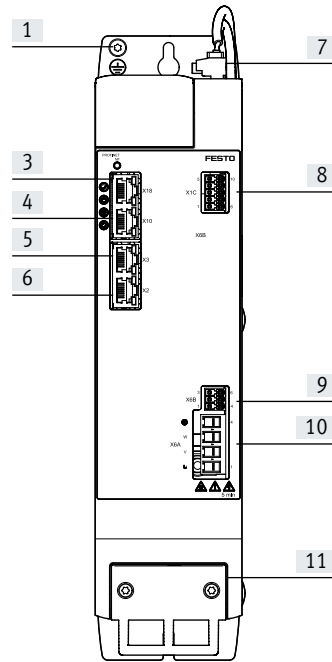

Top view

- [1] Cooling element
- [2] [X1A] I/O interface
- [3] [XF2 OUT] RTE interface port 2
- [4] [XF1 IN] RTE interface port 1
- [5] [X9B] Connection for braking resistor
- [6] [X9A] Supply: mains, DC link and logic voltage
- [7] [X9A] Supply: mains and DC link voltage
- [8] [X9C] Supply: logic voltage

CMMT-AS-...-3A

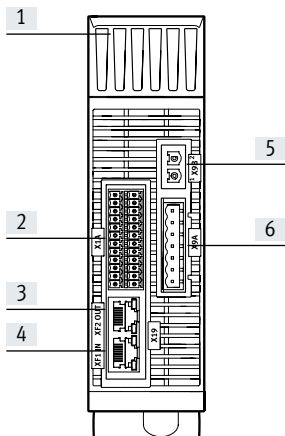

CMMT-AS-C2/C3/C5-...-11A

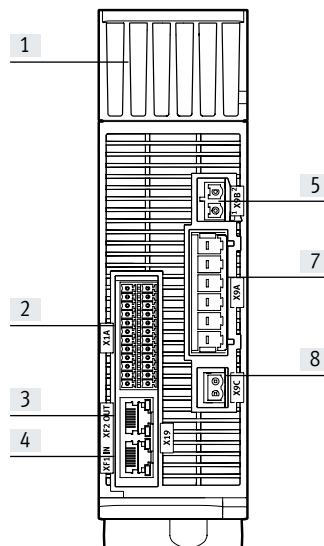

CMMT-AS-C7/C12-...-11A

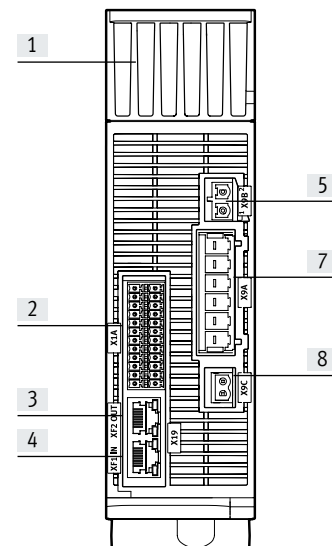

Data sheet

Installation clearance for servo drives

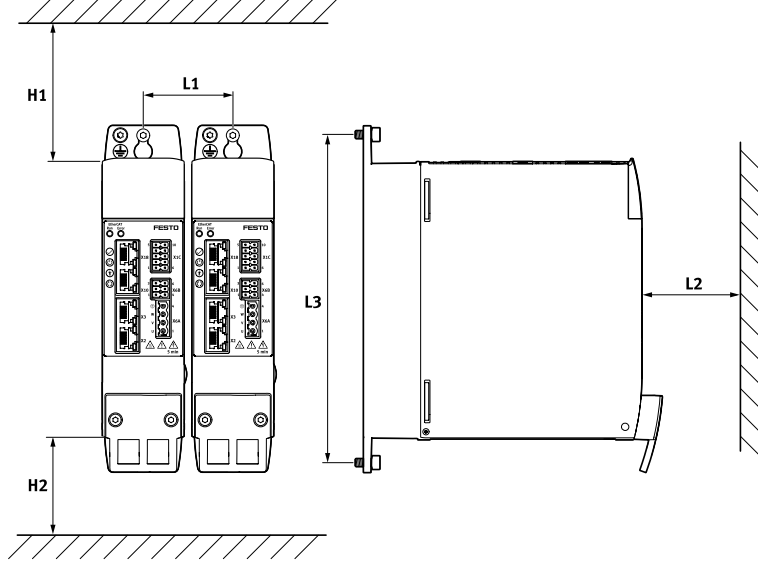

Type	H1	H2 ¹⁾	L1	L2	L3
CMMT-AS-C2-...-3A	70	70	52	70	200
CMMT-AS-C4-...-3A					
CMMT-AS-C2-...-11A	100	70	62	70	230
CMMT-AS-C3-...-11A					
CMMT-AS-C5-...-11A					
CMMT-AS-C7-...-11A	100	70	78	70	300
CMMT-AS-C12-...-11A					

1) An installation clearance of 150 mm underneath the servo drive is recommended for optimum wiring of the motor or encoder cable

Data sheet

Dimensions

Download CAD data → www.festo.com

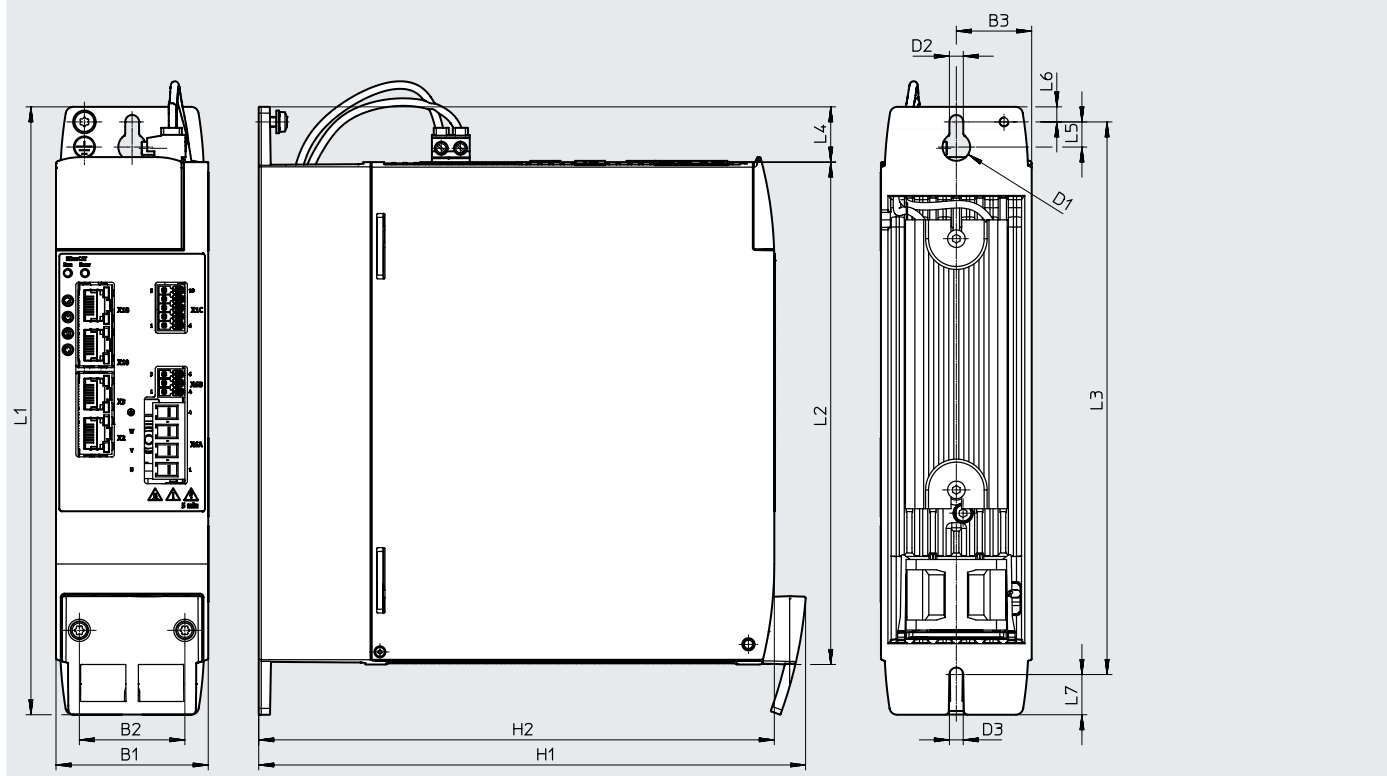

Type	B1	B2	B3	D1 Ø	D2	D3	H1	H2
CMMT-AS-2-...-3A	50	34	25	11	5.5	5.5	183	170
CMMT-AS-4-...-3A								
CMMT-AS-2-...-11A	60	42	29.7	11	5.5	5.5	218	205
CMMT-AS-3-...-11A								
CMMT-AS-5-...-11A								
CMMT-AS-7-...-11A	75	44	37.5	11	5.5	5.5	224	205
CMMT-AS-12-...-11A								

Type	L1	L2	L3	L4	L5	L6	L7
CMMT-AS-2-...-3A	212	170	200	22	10	6	9
CMMT-AS-4-...-3A							
CMMT-AS-2-...-11A	242	198	220	22	10	6	16
CMMT-AS-3-...-11A							
CMMT-AS-5-...-11A							
CMMT-AS-7-...-11A	319	276	300	22	10	6	13
CMMT-AS-12-...-11A							

Data sheet

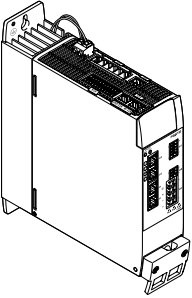
Ordering data	Description	Number of phases	Nominal current	Part no.	Type		
	The assortment of plugs NEKM (→ page 14) is not included in the scope of delivery of the servo drive.	Bus protocol: EtherCAT					
		Single-phase	2		★ 5340819	CMMT-AS-C2-3A-EC-S1	
			4		★ 5340820	CMMT-AS-C4-3A-EC-S1	
		Three-phase	2		★ 5340821	CMMT-AS-C2-11A-P3-EC-S1	
			3		★ 5340822	CMMT-AS-C3-11A-P3-EC-S1	
			5		★ 5340823	CMMT-AS-C5-11A-P3-EC-S1	
			7		★ 8133354	CMMT-AS-C7-11A-P3-EC-S1	
			12		★ 8133355	CMMT-AS-C12-11A-P3-EC-S1	
		Bus protocol: PROFINET RT/IRT					
		Single-phase	2		★ 5340814	CMMT-AS-C2-3A-PN-S1	
			4		★ 5340815	CMMT-AS-C4-3A-PN-S1	
		Three-phase	2		★ 5340816	CMMT-AS-C2-11A-P3-PN-S1	
			3		★ 5340817	CMMT-AS-C3-11A-P3-PN-S1	
			5		★ 5340818	CMMT-AS-C5-11A-P3-PN-S1	
			7		★ 8133352	CMMT-AS-C7-11A-P3-PN-S1	
			12		★ 8133353	CMMT-AS-C12-11A-P3-PN-S1	
		Bus protocol: EtherNet/IP and Modbus TCP					
		Single-phase	2		★ 5340824	CMMT-AS-C2-3A-EP-S1	
			4		★ 5340825	CMMT-AS-C4-3A-EP-S1	
		Three-phase	2		★ 5340826	CMMT-AS-C2-11A-P3-EP-S1	
			3		★ 5340827	CMMT-AS-C3-11A-P3-EP-S1	
			5		★ 5340828	CMMT-AS-C5-11A-P3-EP-S1	
			7		★ 8133356	CMMT-AS-C7-11A-P3-EP-S1	
			12		★ 8133357	CMMT-AS-C12-11A-P3-EP-S1	

Festo core product range



Generally ready for dispatch from the factory within 24 hours
 Generally ready for dispatch from the factory within 5 days

Ordering data – Modular product system

Ordering table					
Series			Condi- tions	Code	Enter code
CMMT-AS-...	-3A	-11A			
Module no.	5111184	5111189			
Series	CMMT			CMMT	CMMT
Motor type	AC synchronous			-AS	-AS
Nominal current					
2 A				-C2	
3 A	–		[1]	-C3	
4 A		–	[2]	-C4	
5 A	–		[1]	-C5	
7 A	–		[1]	-C7	
12 A	–		[1]	-C12	
Nominal input voltage					
230 V AC/50-60 Hz		–		-3A	
400 V AC	–			-11A	
Number of phases					
Single-phase		–			
Three-phase	–			-P3	
Bus protocol/control					
	EtherCAT			-EC	
	PROFINET RT/IRT			-PN	
	EtherNet/IP and Modbus TCP			-EP	
Safety function					
	Standard safety			-S1	-S1

[1] C3, C5, C7, C12 Only with nominal input voltage 11 A

[2] C4 Only with nominal input voltage 3 A

Accessories

Ordering data – Required accessories

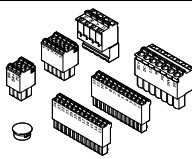
	Description	For CMMT-AS...		Part no.	Type
		-3A	-11A		
Assortment of plugs					
	For single wiring connection	■	-	★ 4325822	NEKM-C6-C16-S
	For double wiring connection	■	-	★ 5054513	NEKM-C6-C16-D
	For single wiring connection	-	■	★ 5119205	NEKM-C6-C45-P3-S
	For double wiring connection	-	■	★ 5118001	NEKM-C6-C45-P3-D
	Not included in the scope of delivery of the servo drive				

Ordering data – Optional accessories

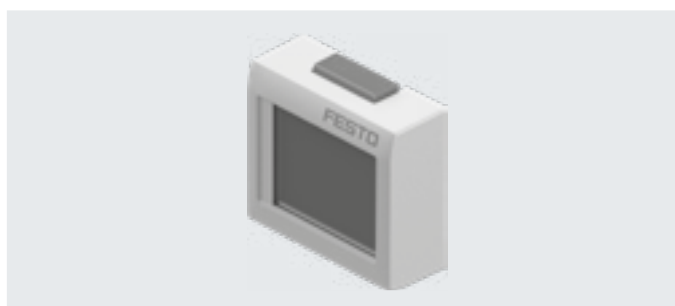

Operator unit CDSB-A1

- Display of full-text messages. This means that errors, warnings and selected data can be read at a glance
 - Easy data backup of parameters and firmware in the unit for e.g. serial commissioning or device replacement
 - One operator unit can be used for several servo drives
- Control element: touchscreen
 - Display: colour TFT
 - Display size: 1.77"
 - User memory: 3 GB
 - USB interface: USB 2.0 type mini
- Additional technical data:
→ Internet: cdsb

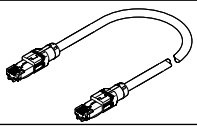

Ambient temperature [°C]	Storage temperature [°C]	Degree of protection	Weight [g]	Part no.	Type
0 ... 60	-20 ... +70	IP20	40	8070984	CDSB-A1
Not included in the scope of delivery of the servo drive					

Ordering data – Optional accessories

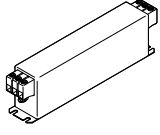
	Description	Part no.	Type
Connecting cable			
	<ul style="list-style-type: none"> • Patch cable for the daisy-chain connection of the bus interfaces X19A/B • Patch cable for master/slave functionality (X10-X10) • Ethernet category Cat 5e • Not included in the scope of delivery of the servo drive 	★ 8082383	NEBC-R3G8-KS-0.2-N-S-R3G8-ET
Mains filter			
	Single-phase, 8 A, sufficient for: 2x CMMT-AS-C2-3A or 1x CMMT-AS-C4-3A	★ 8088928	CAMF-C6-F-C8-3A
	Single-phase, 20 A, sufficient for: 6x CMMT-AS-C2-3A or 3x CMMT-AS-C4-3A	★ 8088929	CAMF-C6-F-C20-3A
	Three-phase, 16 A, sufficient for: 8x CMMT-AS-C2-11A or 5x CMMT-AS-C3-11A or 2x CMMT-AS-C5-11A or 2x CMMT-AS-C7-11A or 1x CMMT-AS-C12-11A	8096868	CAMF-C6-F-C16-11A
	Three-phase, 42 A, sufficient for: 21x CMMT-AS-C2-11A or 14x CMMT-AS-C3-11A or 7x CMMT-AS-C5-11A or 5x CMMT-AS-C7-11A or 3x CMMT-AS-C12-11A	8096894	CAMF-C6-F-C42-11A
Not included in the scope of delivery of the servo drive			

Festo core product range

- ★ Generally ready for dispatch from the factory within 24 hours
- ★ Generally ready for dispatch from the factory within 5 days

Accessories

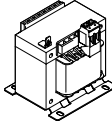
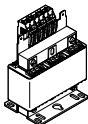
Ordering data – Optional accessories			
	Description	Part no.	Type
Flow control filter			
	Single-phase, 6 A, sufficient for: 2x CMMT-AS-C2-3A or 1x CMMT-AS-C4-3A	★ 8088930	CAMF-C6-FD-C6-3A
	Three-phase, 6 A, sufficient for: 3x CMMT-AS-C2-11A or 2x CMMT-AS-C3-11A or 1x CMMT-AS-C5-11A	8096867	CAMF-C6-FD-C6-11A
Not included in the scope of delivery of the servo drive			

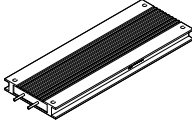

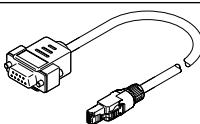
Ordering data – Optional accessories				Data sheets → Internet: cacr					
	Resistance value [Ω]	Nominal power [W]	Part no.	Type					
Braking resistor									
	For type CMMT-AS-								
	C2-3A	C4-3A	C2-11A	C3-11A	C5-11A				
	–	■	–	–	–	72	200	1336611	CACR-LE2-72-W500
	■	■	–	–	■	100	200	1336615	CACR-LE2-100-W500
	–	–	■	■	–	240	200	8091543	CACR-LE2-240-W500
	–	–	■	■	–	240	720	8091544	CACR-KL2-240-W1800
	■	■	–	–	■	100	720	8091545	CACR-KL2-100-W1800
	–	■	–	–	–	67	720	1336617	CACR-KL2-67-W1800
	For type CMMT-AS-								
	C7-11A		C12-11A						
	■		–			72	200	1336611	CACR-LE2-72-W500
	■		–			100	200	1336615	CACR-LE2-100-W500
	■		–			67	720	1336617	CACR-KL2-67-W1800
	■		–			100	720	8091545	CACR-KL2-100-W1800
–		■			50	200	2882342	CACR-LE2-50-W500	
–		■			40	800	2882343	CACR-KL2-40-W2000	
Not included in the scope of delivery of the servo drive									

Ordering data – Optional accessories			
	Description	Part no.	Type
Adapter			
	Required in combination with the linear axes EGC...-M1/M2 or ELGA...-M1/M2 (external displacement encoder) as adapter between encoder cable NEBM-M12G8...-V3 and interface X3 (position encoder 2)	8106112	NEFM-S1G9-K-0.5-R3G8
Not included in the scope of delivery of the servo drive			

Festo core product range

- ★ Generally ready for dispatch from the factory within 24 hours
- ★ Generally ready for dispatch from the factory within 5 days

Accessories

Ordering data – Optional accessories						
	Description	For CMMT-AS-			Part no.	Type
		C2/C4 ...-3A	C2/C3/C5 ...-11A	C7/C12 ...-11A		
Blanking plate						
	<ul style="list-style-type: none"> Used to cover the connections if no operator unit used Included in the scope of delivery of the servo drive 	■	■	■	★ 5395254	C AFC-06-C
Shield clamp						
	<ul style="list-style-type: none"> For fixing in place the shield and strain relief for the motor cable Included in the scope of delivery of the servo drive 	■	–	–	5326867	CAMA-C6-SK-S2
		–	■	–	5335956	CAMA-C6-SK-S3
		–	–	■	★ 8114689	CAMA-C6-SK-S4

Festo core product range



Generally ready for dispatch from the factory within 24 hours
 Generally ready for dispatch from the factory within 5 days