

(GB) Safety  
(DK) Advarselsymboler  
(DE) Warnsymbole  
(ES) Señales de advertencia

(FR) Sécurité  
(IT) Segnali di avvertenza  
(NL) Waarschuwingsymbolen  
(NO) Sikkerhet

(PT) Sinais Avisadores  
(SV) Säkerhet  
(FI) Varoituserkit  
(JP) 安全性

(GB) Warranty  
(DK) Garanti  
(DE) Garantie  
(ES) Garantía

(FR) Garantie  
(IT) Garanzia  
(NL) Garantie  
(NO) Garanti

(PT) Garantia  
(SE) Garanti  
(FI) Takuu  
(JP) 保証



- Vacuum force
- Vakuumkraft
- Vakuumkraft
- Fuerza de vacío
- Force d'aspiration
- Potenza di aspirazione
- Vakuumkracht
- Vakuumkraft
- Vácuo ligado
- Vakuumkraft
- Voimakas imu
- 真空口

- Exhaust
- Udblæs
- Abluft
- Aire procedente
- Evacuation de l'air
- Aria di scarico
- Uitlaatlucht
- Eksos
- Saida de ar
- Utblås
- Poistoilma
- 排気口

- Unrestricted exhaust
- Forbudt blokere udblæsningen
- Abluft nicht blockieren
- Prohibido bloquear la salida del aire
- Interdit de bloquer l'évacuation de l'air
- Lo scarico della pompa non deve essere ostruito
- Pompuitlaat vrijhouden
- Forbudt å blokkere eksos
- O escape da bomba deve ser livre
- Förbjudet blockera utblås
- Ulospuhalluksen esto kielletty
- 無制限の排気



(GB) The Piab Vacuum Pump has a 5 year warranty against manufacturing defects. The warranty is valid for the vacuum pump only and covers no other costs.

(DK) Piab vakuumpumper har 5 års garanti mod fabrikationsfejl. Garantien gælder kun vakuumpumperne, men ikke andre omkostninger eller fragtomkostninger.

(DE) Bei Herstellungsfehlern an der Piab Vakuumpumpe geben wir 5 Jahre Garantie. Verschleißteile wie z.B. Filter sind ausgeschossen.

(ES) La bomba de vacío Piab tiene una garantía de 5 años contra defectos de fabricación. La garantía es válida para la bomba de vacío solamente sin cubrir gastos extras.

(FR) La pompe à vide Piab est garantie 5 ans contre les défauts de fabrication. La garantie est valable uniquement pour la pompe, et ne couvre pas d'autres frais, par exemple les frais d'expédition.

(IT) La pompa a vuoto Piab ha 5 anni di garanzia contro i difetti di fabbricazione. La garanzia e' valida solo per la pompa a vuoto e non copre altri costi.

(NL) Piab vacuümpompen hebben een garantietermijn tegen fabricagefouten van 5 jaar. De garantie geldt alleen voor de pomp en dekt geen andere kosten.

(NO) Piab Vakuumpumper har 5 års garanti mot fabrikkasjonsfeil. Garantien gjelder kun vakuumpumperne og dekker ikke andre kostnader eller fraktkostnader.

(PT) As bombas de vacuo Piab têm 5 anos de garantia contra defeitos de fabrico. A garantia e' válida somente para as bombas de vacuo não cobrindo outros custos.

(SE) Piab Vakuumpump har 5 års garanti mot fabrikkationsfel. Garantien omfattar enbart vakuumpumpen och täcker ej andra kostnader eller fraktkostnader.

(FI) Piab-tyhjöpumpuilla on 5-vuoden takuu koskien valmistusvirheitä. Takuu koskee ainoastaan tyhjöpumpua, eikä peitä muita kustannuksia taikka lähetyskuluja.

(JP) Piab真空ポンプには、製造上の欠陥に対する5年間の保証が付いています。保証は真空ポンプにのみ有効で、その他の費用はかかりません。

piab

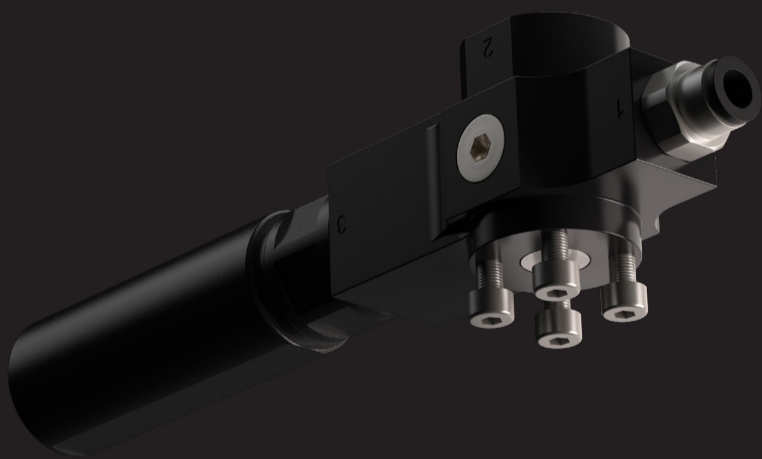

Manual  
Vacuum pump  
VGS™4005

Art. No. 0232475, Rev01  
Piab AB, 2021-06



Piab gives you service all over the world.  
To find your local distributor, please visit [www.piab.com](http://www.piab.com)

piab Evolving automation

## 1. Installations and connections

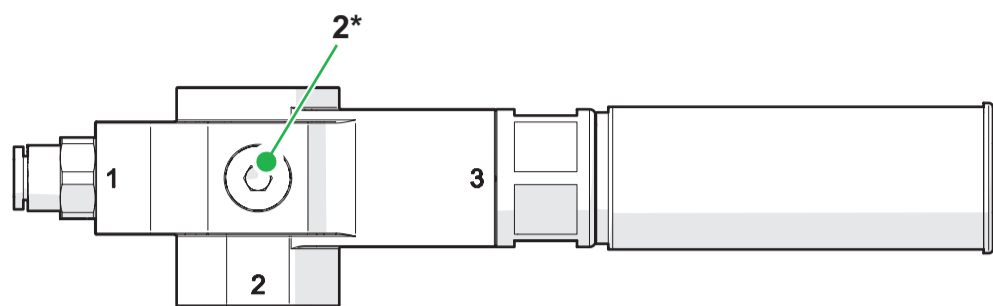
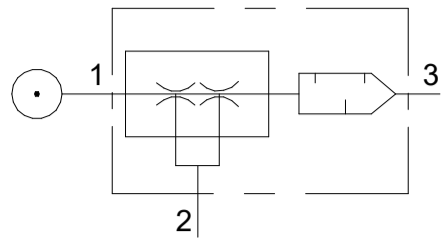

Recommended hose dimension in mm [IN] (internal diameter)

Connections	COAX@ cartridge	
	SX12**	SX42***
1 Compressed air	≥4 [≥0.16]	≥4 [≥0.16]
2 Vacuum	≥8 [≥0.31]	≥10 [≥0.39]
2* Vacuum sensing		
3 Exhaust		

\*\* Applies to hoses up to 3 m [9.8 feet]

\*\*\* Applies to hoses up to 2 m [6.6 feet]

Feed pressure and vacuum level

Description	Unit	COAX@ cartridge	
		SX12	SX42
Max. feed pressure	MPa [psi]	0.7 [101.5]	0.7 [101.5]
Feed pressure range	MPa [psi]	0.5-0.6 [72.5-87]	0.43-0.6 [62.4-87]
Max. vacuum in feed pressure range	-kPa [-inHg]	47-55 [13.9-16.2]	53-64 [15.7-18.9]

## 2. Mounting

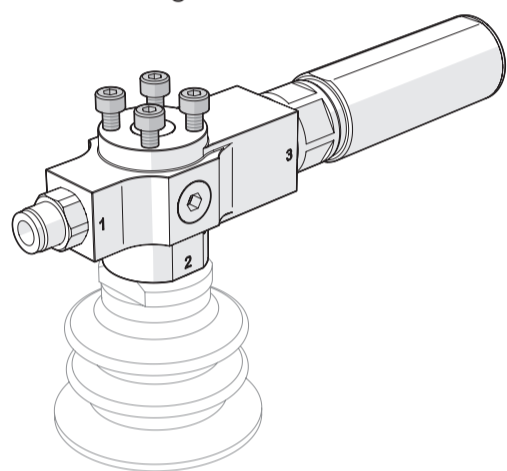

Technical data

Description	Unit	Value
Max. Torque Connection, vacuum G3/8"	Nm	6*
Max. Torque Mounting screws M4	Nm	1**
Max. Load (Static vertical)	kg	70

\*Avoid using NPT (conical) threads

\*\*6 mm thread engagement

## 3. Dimensions

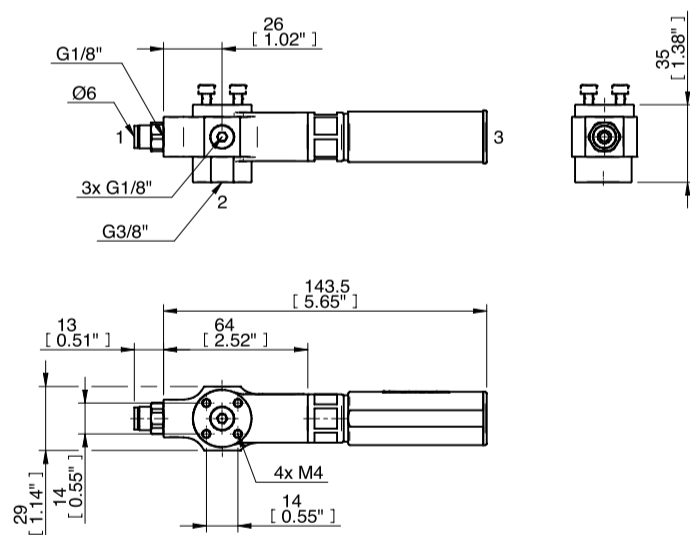

Art. no. 0231207 and 0231208

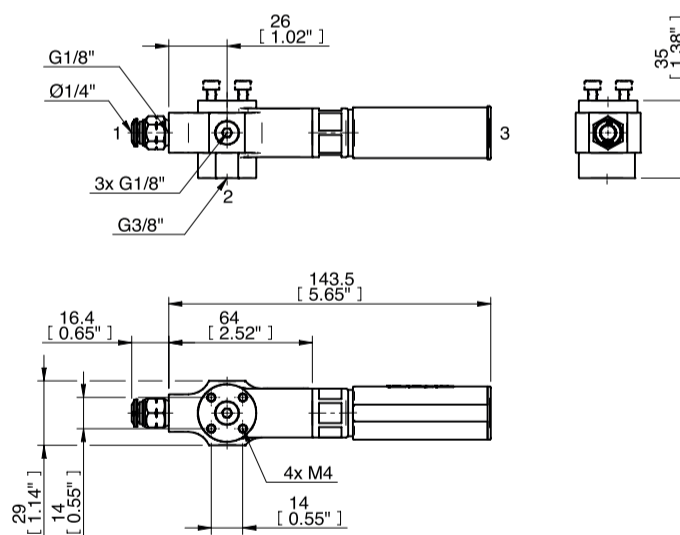

Art. no. 0231209 and 0231210

## 4. Spareparts

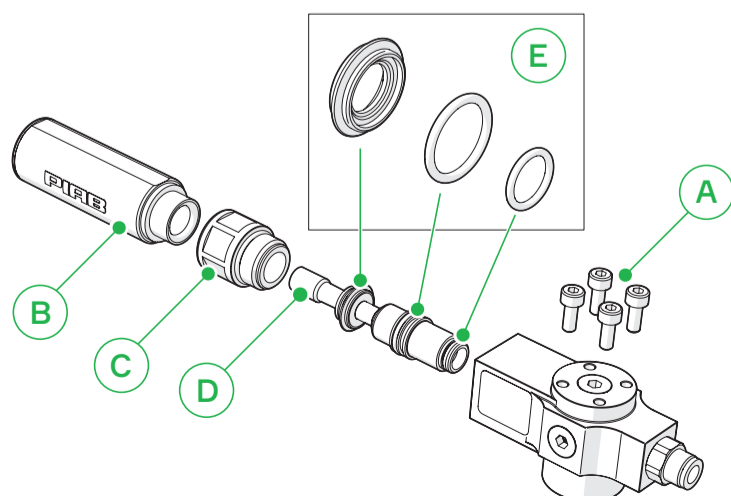

Spare parts and accessories

Description	Art. no.
A Spare part Mounting kit 4xM4	0232668
B Silencer G3/8"	3216009
C Holder VGS4005	0208488
D COAX@cartridge SX12	0205575
D COAX@cartridge SX42	0205724
E Spare part kit COAX SX	0232669