



aerospace  
climate control  
electromechanical  
filtration  
fluid & gas handling  
hydraulics  
**pneumatics**  
process control  
sealing & shielding



# Air Motors

P1V-A Series

1.6, 3.2, 5, 6, 9 & 18kW

Catalogue PDE2555TCUK



ENGINEERING YOUR SUCCESS.

Features	Air motor	Hydraulic motor	Electric motor
Overload safe	***	***	*
Increased torque at higher loads	***	**	*
Easy to limit torque	***	***	*
Easy to vary speed	***	***	*
Easy to limit power	***	***	*
Reliability	***	***	***
Robustness	***	***	*
Installation cost	***	*	**
Ease of service	***	**	*
Safety in damp environments	***	***	*
Safety in explosive atmospheres	***	***	*
Safety risk with electrical installations	***	***	*
Risk of oil leak	***	*	***
Hydraulic system required	***	*	***
Weight	**	***	*
Power density	**	***	*
High torque for size	**	***	*
Noise level during operation	*	***	**
Total energy consumption	*	**	***
Service interval	*	**	***
Compressor capacity required	*	***	***
Purchase price	*	*	***

\* = good, \*\* = average, \*\*\* = excellent



**Important**  
 Before carrying out service activities, make sure the air motor is vented. Before disassembling the motor, disconnect the primary air hose to ensure that the air supply is interrupted.



**Note**  
 All technical data in the catalogue are typical values. The air quality is a major factor in the service life of the motor, see ISO 8573-1.



**WARNING**

**FAILURE OR IMPROPER SELECTION OR IMPROPER USE OF THE PRODUCTS AND/OR SYSTEMS DESCRIBED HEREIN OR RELATED ITEMS CAN CAUSE DEATH, PERSONAL INJURY AND PROPERTY DAMAGE.**

This document and other information from Parker Hannifin Corporation, its subsidiaries and authorized distributors provide product and/or system options for further investigation by users having technical expertise. It is important that you analyze all aspects of your application and review the information concerning the product or system in the current product catalog. Due to the variety of operating conditions and applications for these products or systems, the user, through its own analysis and testing, is solely responsible for making the final selection of the products and systems and assuring that all performance, safety and warning requirements of the application are met. The products described herein, including without limitation, product features, specifications, designs, availability and pricing, are subject to change by Parker Hannifin Corporation and its subsidiaries at any time without notice.

**SALE CONDITIONS**

The items described in this document are available for sale by Parker Hannifin Corporation, its subsidiaries or its authorized distributors. Any sale contract entered into by Parker will be governed by the provisions stated in Parker's standard terms and conditions of sale (copy available upon request).

---

## **Contents**

### **General**

The steps to size .....	4
Principles of Air Motors .....	5
Introduction .....	6 - 9
Air quality & lubrication .....	10 - 11
Air Motors features .....	12
P1V-A Air Motors series .....	13
Material and technical specification .....	14
<b>Air Motors 1600 to 18000 watts</b> .....	15 - 22
Holding brakes .....	16
Technical data .....	17 - 23
Graphs .....	17 - 23
Dimensions .....	24 - 28
<b>Choice of an Air Motor with gear</b> .....	30 - 31
<b>Air Motors with planetary gear boxes</b> .....	32 - 33
Technical data .....	32
Dimensions .....	33
<b>Air Motors with helical (spur) gear boxes</b> .....	34 - 36
Technical data .....	34
Dimensions .....	35 - 37
<b>Air Motors with worm gear boxes</b> .....	38 - 44
Technical data .....	38
Dimensions .....	39 - 44
Shaft & flanges for air motors with worm gear boxes .....	45
Lubrication and service life .....	46
Order code key .....	47

## Choosing the correct air motor for your application

### 1 Which drive principle of the air motor is suitable for your application?

- Air vane motor are suitable for regular operating cycles, speed is very small e.g. 16 rpm
- Tooth gear air motor or turbines are more suitable for continuous operation, 24 hours non-stop, speed is in a upper range, up to 140,000 rpm
- Oil free operation is often an option for these three principles of air motors.

### 2 Which motor materials are suitable for your application?

- Will the air motor work in a normal production area
- Or in a paper industry
- Or in the food processing industry, in contact or not with food
- Or in underwater usage
- Or in the medical, pharmaceutical industries
- Or in potentially explosive areas
- Others, please describe your environment

### 3 How do you calculate the motor power taking the application conditions into consideration?

1. Which rotational direction? Clockwise, anti-clockwise, reversible?
2. Air pressure working range? Which air class quality is available?
3. Which torque and which speed under load do you expect to obtain?
4. Calculate the basic power with the formula

$$P = M \times n / 9550 \text{ with } P \text{ power output in kW, } M \text{ nominal torque in Nm, } n \text{ nominal speed in rpm}$$

5. Check performance data of air motors in our catalogues. Note that all data is at 6 bar in the inlet of the air motor, max 3 meters for tubes and oil lubricated operations.
6. To adapt the difference of air pressure with your operation conditions, please check graphs in our catalogues and how to do it.
7. or you can adapt the need of air to fit your operation conditions by throttling the outlet flow in the air motor you will reduce speed without loss of torque.
8. Check if you need an oil free or not working operation. 1 to 2 drops of oil per cube meter are needed to optimize performance and life time of air motors. Oil free operation will decrease by 10 to 15% the performance of air motors.

### 4 How do you integrate your air motor in your system?

- In which position is the air motor used?
- Do you need to use a brake?
- Do you want to use your own gear box and put it somewhere else in the machine?
- Do you need extra components like fittings, tubes, valves and FRLs?

### 5 How do you ensure a long life and high performance of the air motor?

- Ensure you air quality is in accordance with our specifications, oil or oil free lubrication operations.
- Keep the recommended maintenance intervals

### 6 How do you determine the purchasing and running costs after the air motor installation?

- Keep same level of your air quality.

## Principles of air motor functioning

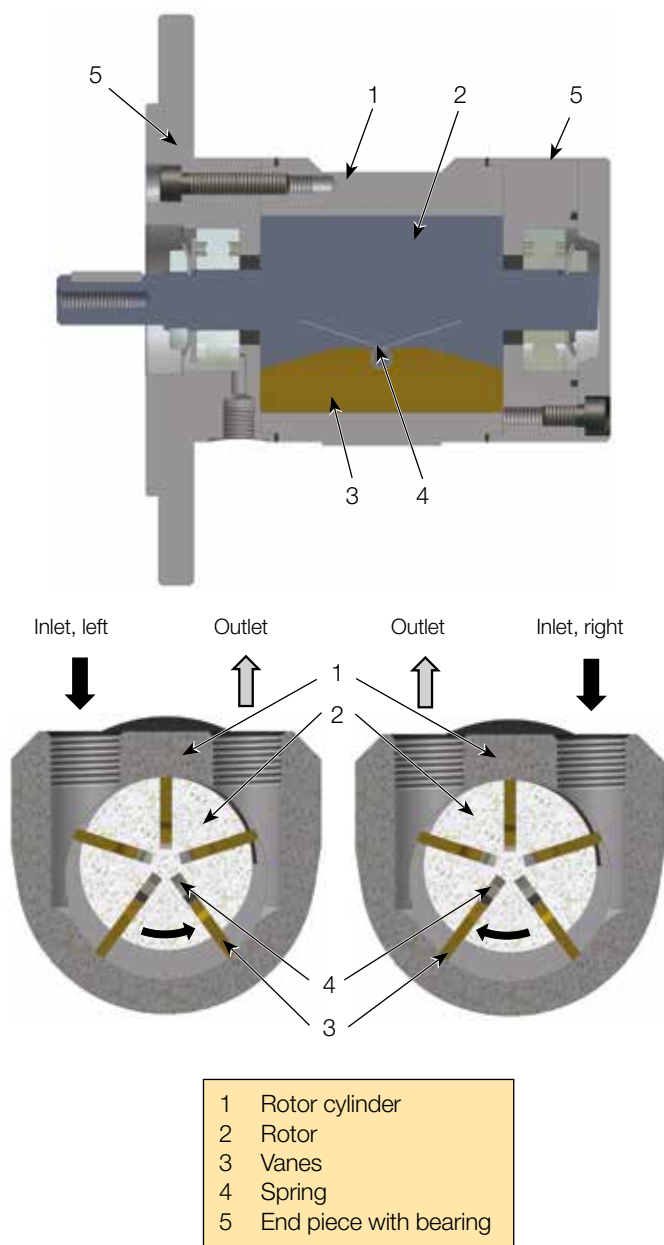

## Torque, power and air consumption graphs

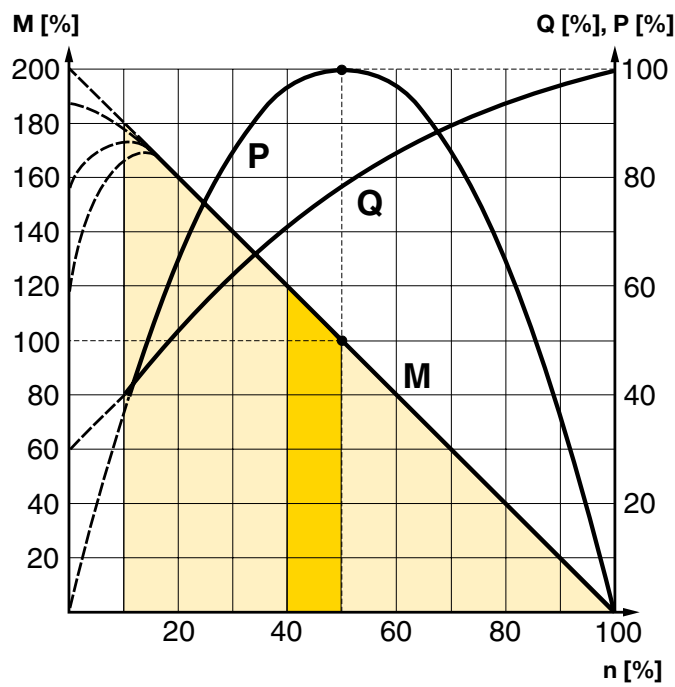

**P = power**  
**M = torque**  
**Q = air consumption**  
**n = speed**

**Possible working range of motor.**  
**Optimum working range of motor.**  
 Higher speeds = more vane wear  
 Lower speeds with high torque = more gearbox wear

There are a number of designs of air motors. Parker has chosen to use the vane rotor design, because of its simple design and reliable operation. The small external dimensions of vane motors make them suitable for all applications.

The principle of the vane motor is that a rotor with a number of vanes is enclosed in a rotor cylinder. The motor is supplied with compressed air through one connection and air escapes from the other connection. To give reliable starting, the springs press the vanes against the rotor cylinder. The air pressure always bears at right angles against a surface. This means that the torque of the motor is a result of the vane surfaces and the air pressure.

The performance characteristics of each motor are shown in a family of curves as above, from which torque, power and air consumption can be read off as a function of speed. Power is zero when the motor is stationary and also when running at free speed (100%) with no load. Maximum power (100%) is normally developed when the motor is driving a load at approximately half the free speed (50%).

Torque at free speed is zero, but increases as soon as a load is applied, rising linearly until the motor stalls. As the motor can then stop with the vanes in various positions, it is not possible to specify an exact torque. However, a minimum starting torque is shown in all tables.

Air consumption is greatest at free speed, and decreases with decreasing speed, as shown in the above diagram.

**Performance**

The performance of an air motor is dependent on the inlet pressure. At a constant inlet pressure, air motors exhibit the characteristic linear output torque / speed relationship. However, by simply regulating the air supply, using the techniques of throttling or pressure regulation, the output of an air motor can easily be modified. The most economical operation of an air motor (least wear, least air consumption, etc.) is reached by running close to nominal speed. By torque of  $M = 0$ , the maximum speed (idle speed) is reached. Shortly before standstill ( $n = 0$ ), the air motor reaches its maximum torque ( $M_{max} = 2 \times M_0$ ). At nominal speed ( $n_n$ ), for example in the middle of the speed range, air motor reaches its maximum power output ( $P_{max}$ ).

**Energy Efficiency**

A pneumatic motor achieves its maximum power when it is operating as close as possible to its rated speed (50% of the rated idle speed). The energy balance is best in this area, because the compressed air is used efficiently.

**Air pressure correction factors**

To adapt the difference of air pressure with your operation conditions

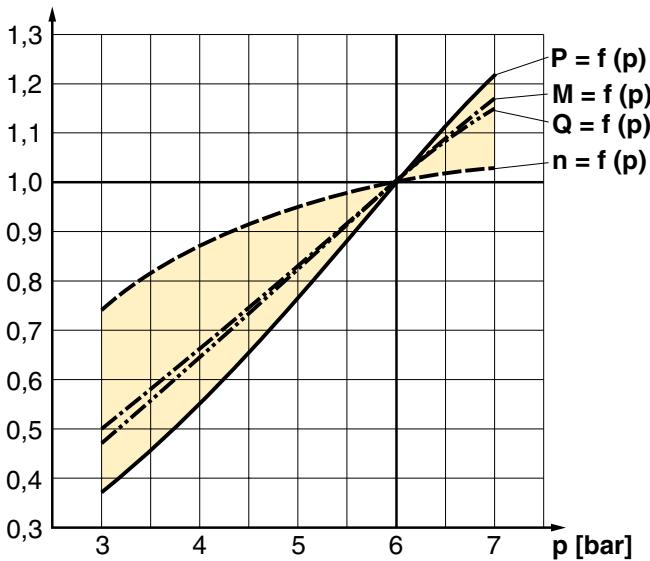

P = Power, M = Torque, Q = Air consumption, N = Speed

Pressure (p) bar / PSI	Power (P) %	Speed (n) %	Torque (M) %	Air Consumpt. (Q) %
7 / 99	121	103	117	117
6 / 85	100	100	100	100
5 / 71	77	95	83	83
4 / 57	55	87	67	67
3 / 42	37	74	50	50

All catalogue data and curves are specified at a supply pressure of 6 bar to the motor. This diagram shows the effect of pressure on speed, specified torque, power and air consumption. Start off on the curve at the pressure used and then look up to the lines for power, torque and air consumption. Read off the correction factor on the Y axis for each curve and multiply this by the specified catalogue data in the table, or data read from the torque and power graphs.

Example: at 4 bar supply pressure, the power is only 0.55 x power at 6 bar supply pressure. This example shows how strongly power falls if supply pressure is reduced. You must therefore ensure that the motor is supplied through pipes of sufficient diameter to avoid pressure drop.

The speed and torque can also be regulated by installing a pressure regulator in the inlet pipe. This means that the motor is constantly supplied with air at lower pressure, which means that when the motor is braked, it develops a lower torque on the output shaft.

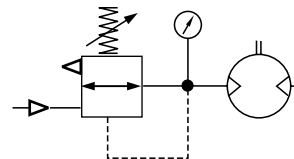

Pressure regulation at motor inlet.

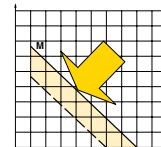

Theoretical torque curve change caused by pressure change

**Speed regulation, air flow reduction**

Every size reduction or restriction on the air line, whether of the supply hose itself or fittings, before the air motor affects the amount of the supplied air. By throttling you reduce the speed of your motor and simultaneously, the required torque. That means that you reduce the motor performance. The most common way to reduce the speed of a motor is to install a flow control valve in the air outlet, you can set the speed without loss of the torque. When the motor is used in applications where it must reverse and it is necessary to restrict the speed in both directions, flow control valves with by-pass should be used in both directions. If the inlet air is restricted, the air supply is restricted and the free speed of the motor falls, but there is full pressure on the vanes at low speeds. This means that we get full torque from the motor at low speeds despite the low air flow. Since the torque curve becomes "steeper", this also means that we get a lower torque at any given speed than would be developed at full air flow. The benefit of throttling the inlet is that air consumption is reduced, whereas throttling the exhaust air maintains a slightly higher starting torque.

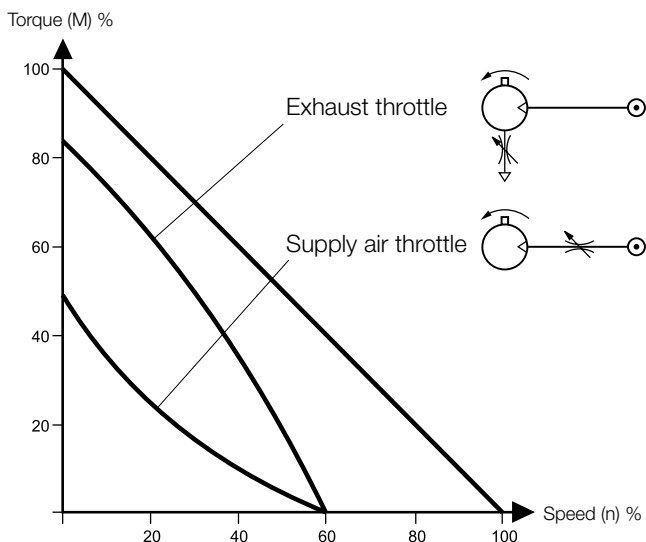

### Throttling

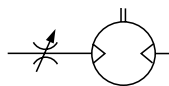

Supply or exhaust throttling, non-reversible motor

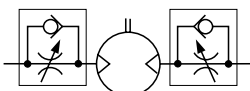

Supply throttling, reversible motor

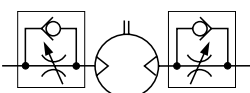

Exhaust throttling, reversible motor

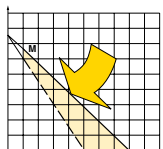

Torque curve change caused by throttling

### Component choice for air supply

#### Direction of motor rotation

The direction of rotation of reversible motors is obtained by supplying inlet L or inlet R with compressed air. The motor can be stopped and started continually without damage occurring.

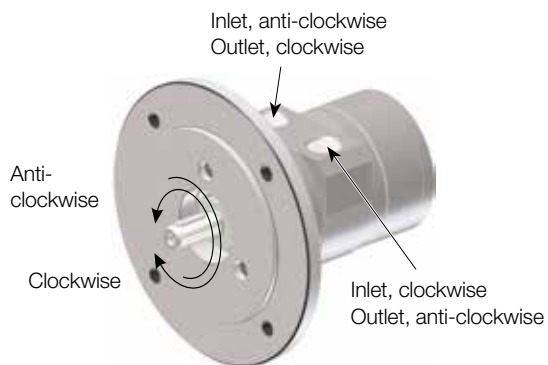

Reversible means in both directions.

### Compressed air quality

Oil and oil mist are avoided whenever possible to ensure a clean work environment. In addition, purchasing, installation and maintenance of oil equipment can be expensive. All users in all industries now try to avoid using components which have to be lubricated. The P1V air motors series are equipped with vanes for intermittent lubrication free operation as standard, which is the most common application of air motors.

#### Oil mist



If oil mist is used (approx. 1 drop of oil per m<sup>3</sup> of compressed air), the oil not only acts as a lubricant but also protects against corrosion. This means that compressed air with a certain water content may be used without causing corrosion problems inside the motor. ISO8573-1 purity class 3.-.5 may be used without difficulty.

#### ISO 8573-1 purity classes

Quality class	Contaminants		Water	Oil
	particle size (µm)	max. concentration (mg/m <sup>3</sup> )	max. pressure dew point (°C)	max. concentration (mg/m <sup>3</sup> )
<b>1</b>	0.1	0.1	-70	0.01
<b>2</b>	1	1	-40	0.1
<b>3</b>	5	5	-20	1.0
<b>4</b>	15	8	+3	5.0
<b>5</b>	40	10	+7	25
<b>6</b>	-	-	+10	-

For example: compressed air to purity class 3.4.3. This means a 5 µm filter (standard filter), dew point +3°C (refrigerant cooled) and an oil concentration of 1,0 mg oil/m<sup>3</sup> (as supplied by a standard compressor with a standard filter).

## Air supply

Since the supply pressure at the air motor inlet port is of considerable importance for obtaining the power, speed and torque quoted in the catalogue, the recommendations below should be observed.

The following data must be complied with:

- Supply pressure: 7 bar
- Regulator pressure setting: 6.7 bar
- Pipe length between air treatment unit and valve: max. 1 m
- Pipe length valve and air motor: max 2 m

The pressure drop through the air preparation unit, pipe, valve means that 6 bar pressure is obtained at the motor supply port. Please refer to the correction diagram and factors to see what lower supply pressure means for power, speed and torque.

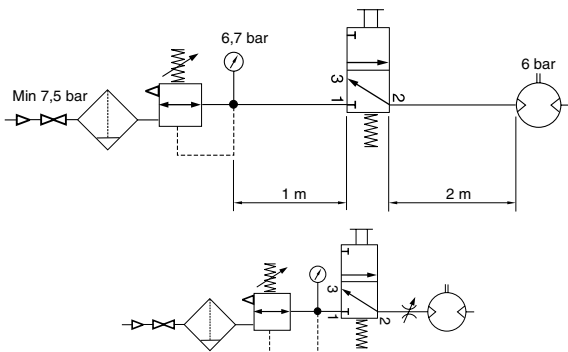

Shut-off, filtering, pressure regulation and control valve

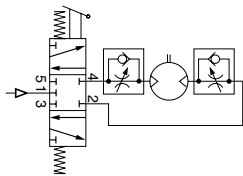

Reversible motor with 5/3 control valve

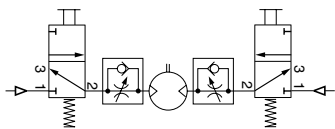

Reversible motor with two 3/2 control valves

The air with which the motor is supplied must be filtered and regulated. Directional valves are needed to provide it with air, to get the motor to rotate when we want it to. These valves can be equipped with several means of actuation, such as electric, manual and pneumatic control. When the motor is used in a non-reversible application, it is sufficient to use a 2/2 or 3/2 valve function for supply. Either one 5/3 or two 3/2 valve functions are needed for a reversible motor, to ensure that the motor receives compressed air and the residual air outlet is vented. A flow control valve can be installed in the supply pipe to regulate the motor speed if the motor is not used as a reversible motor.

One flow control valve with by-pass is needed to regulate each direction of rotation if the motor is used as a reversible motor. The built-in check valve will then allow air from the residual air outlet to escape through the outlet port in the control valve. The compressed air supply must have sufficiently large pipes and valves to give the motor the maximum power. The motor needs 6 bar at the supply port all the time. For example, a reduction of pressure to 5 bar reduces the power developed to 77% and to 55% at 4 bar!

## Silencing

Exhaust silencer

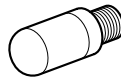

Central silencer

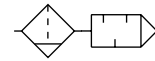

The noise from an air motor consists of both mechanical noise and a pulsating noise from the air flowing out of the outlet. The installation of the motor has a considerable effect on mechanical noise. It should be installed so that no mechanical resonance effects can occur. The outlet air creates a noise level which can amount to 125 dB(A) if the air is allowed to exhaust freely into the atmosphere. Various types of exhaust silencers are used to reduce this level. The most common type screws directly onto the exhaust port of the motor. Since the motor function causes the exhaust air to pulsate, it is a good idea to allow the air to exhaust into some kind of chamber first, which reduces the pulsations before they reach the silencer. The best silencing method is to connect a soft plastic hose to a large central silencer with the largest possible area, to reduce the speed of the out-flowing air as far as possible.

**Note!** Remember that if a silencer which is too small or is blocked, generates back pressure on the outlet side of the motor, which reduces the motor power.

**Note!** Inlet and exhaust air flows are critical for reaching the best performances.

## CE marking

The air motors are supplied as "Components for installation" – the installer is responsible for ensuring that the motors are installed safely in the overall system. Parker Pneumatic guarantees that its products are safe, and as a supplier of pneumatic equipment we ensure that the equipment is designed and manufactured in accordance with the applicable EU directive.

Most of our products are classed as components as defined by various directives, and although we guarantee that the components satisfy the fundamental safety requirements of the directives to the extent that they are our responsibility, they do not usually carry the CE mark. Nevertheless, most P1V-A motors without gear boxes carry the CE mark because they are ATEX certified (for use in explosive atmospheres).

The following are the currently applicable directives:

- Machinery Directive (essential health and safety requirements relating to the design and structure of machines and safety components)
- EMC Directive
- Simple Pressure Vessels Directive
- Low Voltage Directive
- ATEX Directive (ATEX = ATmosphere EXplosive)



## Torque, power and air consumption graphs

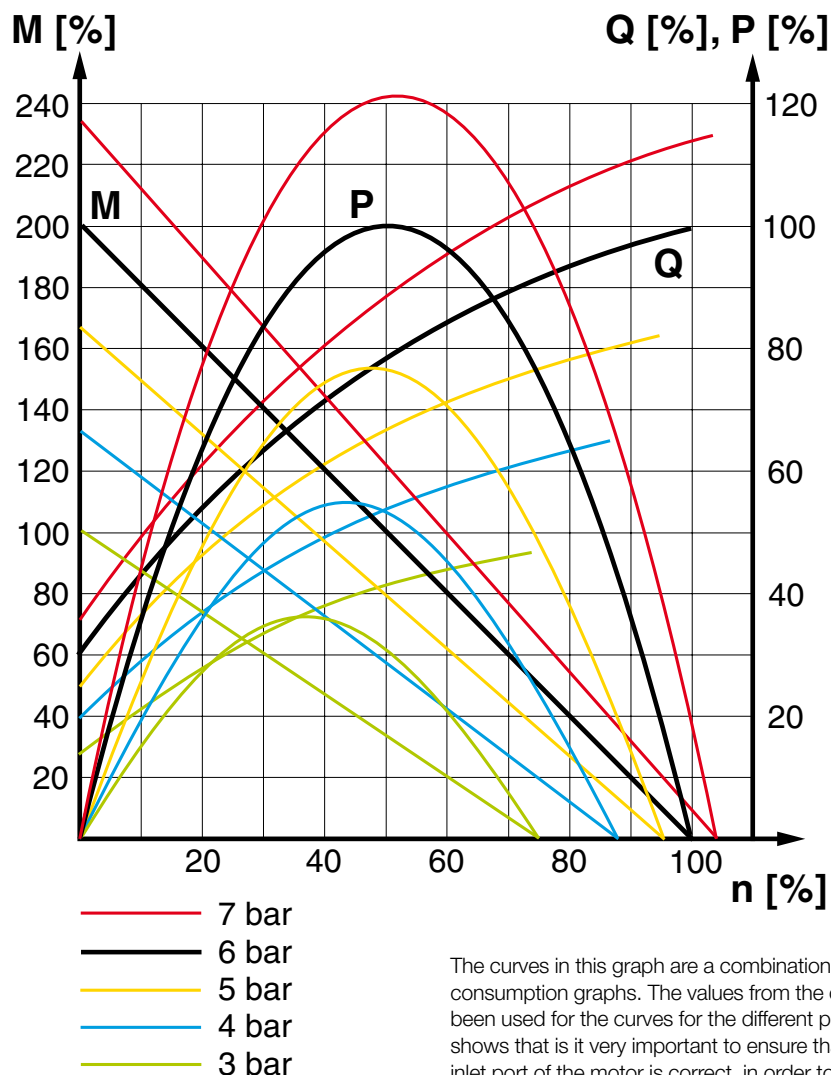

<b>P = power</b>	<b>Q = air consumption</b>
<b>M = torque</b>	<b>n = speed</b>

The curves in this graph are a combination of the torque, power and air consumption graphs. The values from the correction diagram have also been used for the curves for the different pressure values. The graph also shows that it is very important to ensure that the pressure supplied to the inlet port of the motor is correct, in order to allow the motor to work at maximum capacity. If the valve supplying a large motor is too small or if the supply line is underspecified, the pressure at the inlet port may be so low that the motor is unable to do its work. One solution would be to upgrade the valve and supply system, or alternatively you could replace the motor with a smaller motor with lower air consumption. The result would be increased pressure at the inlet port, which means that the smaller motor could carry out the necessary work. However, you may need to select a smaller motor with a lower free speed in order to obtain sufficient torque at the outgoing shaft.

### Choice of an air motor, general

The motor to be used should be selected by starting with the torque needed at a specific spindle speed. In other words, to choose the right motor, you have to know the required speed and torque. Since maximum power is reached at half the motor's free speed, the motor should be chosen so that the point aimed at is as close as possible to the maximum power of the motor.

The design principle of the motor means that higher torque is generated when it is braked, which tends to increase the speed. This means that the motor has a kind of speed selfregulation function built in. Use the following graph to choose the correct motor size and the correct type of gear as appropriate. The graph contains the points for the maximum torque of each motor at maximum power. Put in your point on the graph and select a marked point above and to the right of the point you need.

Then check the characteristic graph of each motor to find more accurate technical data. Always select a motor where the data required is in the orange field. Also use the correction diagram to see what it would mean to use different air supply pressures or different air flow in the motor.

**Tip:** Select a motor which is slightly too fast and powerful, regulate its speed and torque with a pressure regulator and/or restriction to achieve the optimum working point.

Do you need any support to select the right air motor, please feel free to consult your local sales office.

# Specifying air quality (purity) in accordance with ISO8573-1:2010, the international standard for Compressed Air Quality

ISO8573-1 is the primary document used from the ISO8573 series as it is this document which specifies the amount of contamination allowed in each cubic metre of compressed air.

ISO8573-1 lists the main contaminants as Solid Particulate, Water and Oil. The purity levels for each contaminant are shown separately in tabular form, however for ease of use, this document combines all three contaminants into one easy to use table.

ISO8573-1:2010 CLASS	Solid Particulate			Mass Concentration mg/m <sup>3</sup>	Water		Oil
	Maximum number of particles per m <sup>3</sup>				Vapour Pressure Dewpoint	Liquid g/m <sup>3</sup>	Total Oil (aerosol liquid and vapour) mg/m <sup>3</sup>
	0,1 - 0,5 micron	0,5 - 1 micron	1 - 5 micron				
0	As specified by the equipment user or supplier and more stringent than Class 1						
1	≤ 20 000	≤ 400	≤ 10	-	≤ -70 °C	-	0,01
2	≤ 400 000	≤ 6 000	≤ 100	-	≤ -40 °C	-	0,1
3	-	≤ 90 000	≤ 1 000	-	≤ -20 °C	-	1
4	-	-	≤ 10 000	-	≤ +3 °C	-	5
5	-	-	≤ 100 000	-	≤ +7 °C	-	-
6	-	-	-	≤ 5	≤ +10 °C	-	-
7	-	-	-	5 - 10	-	≤ 0,5	-
8	-	-	-	-	-	0,5 - 5	-
9	-	-	-	-	-	5 - 10	-
X	-	-	-	> 10	-	> 10	> 10

## Specifying air purity in accordance with ISO8573-1:2010

When specifying the purity of air required, the standard must always be referenced, followed by the purity class selected for each contaminant (a different purity class can be selected for each contamination if required).

An example of how to write an air quality specification is shown below:

### ISO 8573-1:2010 Class 1.2.1

ISO 8573-1:2010 refers to the standard document and its revision, the three digits refer to the purity classifications selected for solid particulate, water and total oil. Selecting an air purity class of 1.2.1 would specify the following air quality when operating at the standard's reference conditions :

#### Class 1 - Particulate

In each cubic metre of compressed air, the particulate count should not exceed 20,000 particles in the 0.1 - 0.5 micron size range, 400 particles in the 0.5 - 1 micron size range and 10 particles in the 1 - 5 micron size range.

#### Class 2 - Water

A pressure dewpoint (PDP) of -40°C or better is required and no liquid water is allowed.

#### Class 1 - Oil

In each cubic metre of compressed air, not more than 0.01mg of oil is allowed. This is a total level for liquid oil, oil aerosol and oil vapour.

## ISO8573-1:2010 Class zero

- Class 0 does not mean zero contamination.
- Class 0 requires the user and the equipment manufacturer to agree contamination levels as part of a written specification.
- The agreed contamination levels for a Class 0 specification should be within the measurement capabilities of the test equipment and test methods shown in ISO8573 Pt 2 to Pt 9.
- The agreed Class 0 specification must be written on all documentation to be in accordance with the standard.
- Stating Class 0 without the agreed specification is meaningless and not in accordance with the standard.
- A number of compressor manufacturers claim that the delivered air from their oil-free compressors is in compliance with Class 0.
- If the compressor was tested in clean room conditions, the contamination detected at the outlet will be minimal. Should the same compressor now be installed in typical urban environment, the level of contamination will be dependent upon what is drawn into the compressor intake, rendering the Class 0 claim invalid.
- A compressor delivering air to Class 0 will still require purification equipment in both the compressor room and at the point of use for the Class 0 purity to be maintained at the application.
- Air for critical applications such as breathing, medical, food, etc typically only requires air quality to Class 2.2.1 or Class 2.1.1.
- Purification of air to meet a Class 0 specification is only cost effective if carried out at the point of use.

## New Technology

The P3X Lite air preparation system is constructed from ultra light weight technopolymers instead of the traditional aluminium or zinc die cast, this means that is up to 45% lighter than conventional units.

This non-metal construction also means that the P3X Lite is corrosion free enabling it to be used in harsh industrial environments where anti freeze or aggressive synthetic oils are present.

The use of technopolymers in the design of P3X Lite has facilitated a universal body design, this has resulted in reducing the number of variants required to cover the full spectrum of applications. This can dramatically lower logistic costs and simplify stock holding for customers making the P3X Lite a very cost effective solution.



## New Nano Mist Technology, New Lubricator Concept. Self-Adjusting.

With conventional lubricators, only the oil volume per time unit can be adjusted. If the demand changes, the quantity dispensed still remains constant.

The P3X Lite lubricator concept sets new benchmarks here. For the first time, the oil volume is automatically adjusted to the flow rate. This ensures that there is neither too little nor too much oil in the system, which leads to clear economic and ecological advantages. In addition, with conventional systems, the distance between the lubricator and the equipment has to be less than 8 meters. With larger distances, the dispensed oil is deposited as a wall flow. The new lubricator principle of the P3X Lite allows for distances of up to 40 meters. This opens up new scope for the design of even more efficient production systems.

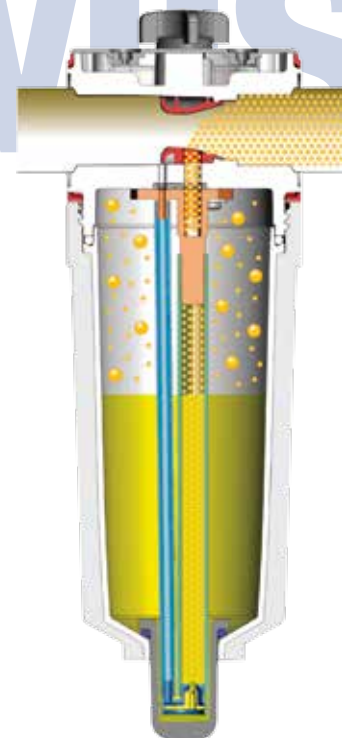

# P1V-A Air Motors

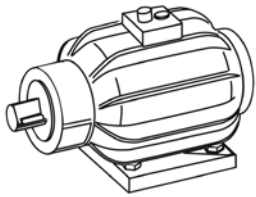

Air motors have much smaller installation dimensions than corresponding electric motors.

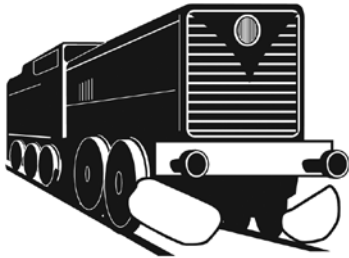

Air motors can be loaded until they stall, without damage. They are designed to be able to withstand the toughest heat, vibration, impact etc.



Air motors can be stopped and started continually without damage.



The simple design principle of air motors make them very easy to service.



The weight of an air motor is several times less than corresponding electric motors.

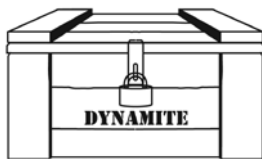

Air motors can be used in the harshest environments.

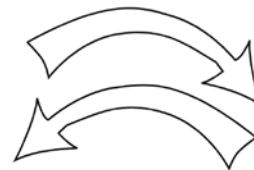

The motors are reversible as standard.



The reliability of air motors is very high, thanks to the design and the low number of moving parts.

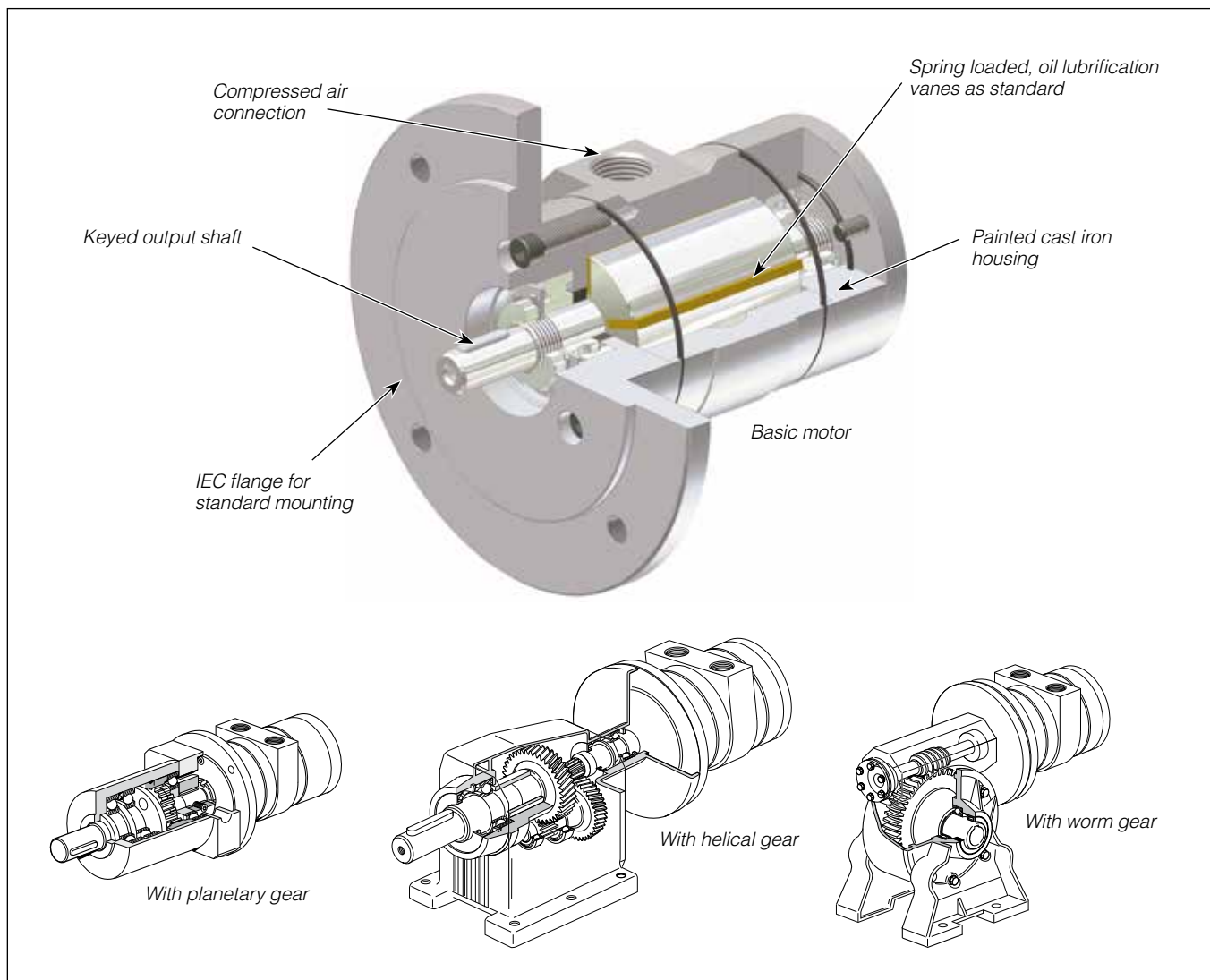

## Air Motors

P1V-A is a range of reversible air motors intended for heavy and demanding applications. The motor housings are made from painted cast iron, and the components sealed to permit operation in damp and dirty environments.

The range contains 6 different sizes with power ratings of 1600 to 18 000 Watts. The basic motors can be supplied with built-in gearboxes, either planetary, helical or worm drives, to provide the correct speed of rotation and torque, and the correct installation mountings.

### Basic motors

All pneumatic motors have very good starting and low speed running characteristics. They are also equipped with vanes for intermittent or permanent oil lubrication as standard. The simple construction of the motors makes them very reliable, with long service life and they are easy to service.

### Motors with planetary gears

A P1V-A combined with a planetary gear has small installation dimensions, low weight in relation to performance, free installation position, IEC flange mounting as standard, in line output shaft and high efficiency.

### Motors with helical gears

A P1V-A combined with a helical gear has high efficiency, simple installation with flange or foot, and competitive pricing. Oil-bath gears mean that the installation position must be decided beforehand. The installation position governs the amount of oil in the gear and the location of filling and drain plugs.

### Motors with worm gears

A P1V-A combined with a worm drive gear has the following characteristics: gearboxes with high gear ratios are self-locking, which means that they can be used to maintain the output shaft in position, simple installation with the flange on the left or right sides or with a foot, small installation dimensions and competitive pricing. Oil-bath gears mean that the installation position must be decided beforehand. The installation position governs the amount of oil in the gear and the location of filling and drain plugs.

## Technical data

**Note:** All technical data are based on a working pressure of 6 bar and with oil.  
Speed tolerance accuracy in between clock and anti-clockwise directions is  $\pm 10\%$ .

Air motor size & type	P1V-A160	P1V-A320	P1V-A500	P1V-A600	P1V-A900	P1V-AJ00
Nominal power (watts)	1600	3200	5000	6000	9000	18000
Working pressure (bar)	3 to 7 / 6 in explosive atmosphere				3 to 7	
Working temperature (°C)	-20 to +110 without gear					
Ambient temperature (°C)	-20 to +40 in explosive atmosphere without gear					
Air flow required (NI/min)	1900	3900	5800	7900	10000	20000
Min pipe ID, inlet (mm)	15	19	25	25	25	43
Min pipe ID, outlet (mm)	19	25	32	32	32	63.5

### Choice of air the treatment unit: recommended min. air flow [l/mn] at p1=7,5 bar and 0,8 bar pressure drop

Air flow [l/mn]	2090	4290	6380	8690	11000	22000
-----------------	------	------	------	------	-------	-------

### Choice of air the valve: recommended min. nominal air flow [l/mn] at p1=6 bar and 1 bar pressure drop

Air flow [l/mn]	2185	4485	6670	9085	11500	23000
Medium	40µm filtered, oil mist lubricated compressed air					
Oil operation	1-2 drop per cube meter, ISO 8573-1 purity class 3.-.5					
Recommended oil	ISO 8573-1 purity class 3.-.5					
Sound level free outlet (dB(A))	125	123	190	122	-	-
With outlet silencer (dB(A))	Consult your local technical support					

**Note:** Sound levels are measured at free speed with the measuring instrument positioned 1 meter away from the air motor at an height of 1 meter.

## Material specification

Air motor size & type	P1V-A160	P1V-A320	P1V-A500	P1V-A600	P1V-A900	P1V-AJ00
<b>Without gear box option</b>						
Motor housing	Cast iron, synthetic paint, silver grey color					
Shaft	High grade steel					
Shafts Key	Hardened steel					
External seal	Nitrile rubber, NBR					
Internal parts	High grade steel					
Internal seals	Nitrile rubber, NBR					
Vanes	Patented material, no public data					
Screws	Zinc coated steel					
<b>With gear box option, common data</b>						
Housing	Alloy steel, synthetic paint, silver grey color				-	-
Shaft	High grade steel				-	-
Shafts Key	Hardened steel				-	-
Shafts seal	Nitrile rubber, NBR				-	-
Screws	Zinc coated steel				-	-
<b>With planetary gear box option</b>						
Housing	Alloy steel, synthetic paint, silver grey color				-	-
<b>With helical (spur) gear box option</b>						
Housing	Aluminium or cast iron, synthetic paint, silver grey color				-	-
<b>With worm gear box option</b>						
Housing	Aluminium or cast iron, synthetic paint, silver grey color				-	-
Internal pinion	Chili cast phosphor bronze				-	-
Worm	Alloyed, hardened steel				-	-

**Note!** All technical data are based on a working pressure of 6 bar and with oil.  
 Speed tolerance accuracy is  $\pm 10\%$ .



CE II 2GD c IIC T3 (200°C) X

For 1600, 3200, 5000, 6000 Watts

**Note!** Inlet and exhaust air flows are critical for reaching the best performances.

**A: Basic reversible motor without gear box (A), IEC flange, ATEX, with planetary (B) or spur (D) gear boxes**

Max power	Free speed	Nominal speed	Nominal torque	Min starting torque	Air consumption	Connection	Min pipe ID	Weight	Mounting	Max permissible shaft loading		At A2/2	Gear box type	Order code
										F radial (N)	F axial (N)			
Watt	rpm	rpm	Nm	Nm	l/s	BSPP	mm	kg	Flange			mm		
1600	9000	4500	3.4	5.1	31.7	G1/2	15/19	5.2	IEC71	1000	600	15.0	Without	<b>P1V-A160A0900</b>
1600	3000	1500	10.2	15.3	31.7	G1/2	15/19	9.5	IEC80	550	1500	20.0	Spur	<b>P1V-A160D0300</b>
1600	1400	700	21.8	32.7	31.7	G1/2	15/19	9.5	IEC80	1200	880	20.0	Helical	<b>P1V-A160B0140</b>
3200	7000	3500	8.7	13.1	65.0	G3/4	19/25	10.3	IEC80	1400	700	20.0	Without	<b>P1V-A320A0700</b>
3200	3000	1500	20.4	30.6	65.0	G3/4	19/25	15.4	IEC90	800	1450	25.0	Spur	<b>P1V-A320D0300</b>
3200	1400	700	43.7	65.5	65.0	G3/4	19/25	13.6	IEC90	1600	1350	25.0	Helical	<b>P1V-A320B0140</b>
5000	6000	3000	15.9	23.9	96.7	G1	25/32	17.0	IEC90	1900	900	25.0	Without	<b>P1V-A500A0600</b>
5000	3000	1500	31.8	47.7	96.7	G1	25/32	25.8	IEC100	1250	950	30.0	Spur	<b>P1V-A500D0300</b>
5000	1450	725	65.9	98.8	96.7	G1	25/32	26.8	IEC100	2650	1150	30.0	Helical	<b>P1V-A500B0145</b>
6000	7000	3500	16.4	24.6	131.7	G1	25/32	17.0	IEC90	1900	900	25.0	Without	<b>P1V-A600A0700</b>
6000	3500	1750	32.7	49.1	131.7	G1	25/32	25.8	IEC100	1250	950	30.0	Spur	<b>P1V-A600D0350</b>
6000	1600	800	71.6	107.4	131.7	G1	25/32	26.8	IEC100	2650	1150	30.0	Helical	<b>P1V-A600B0160</b>
9000	6000	3000	28.6	43.0	166.7	G1	25/32	33.0	IEC112A	7500	1100	30.0	Without	<b>P1V-A900A0600</b>
18000	6000	3000	57.3	85.9	333.3	G2	43/63.5	54.0	IEC112A	7500	1100	30.0	Without	<b>P1V-AJ00A0600</b>

Maximum admissible speed (idling)  
 Air consumption at the maximum air motor power

**Permitted shaft loadings**

Max permitted load on output shaft for basic motors (based on 10,000,000 revolutions of the output shaft, with 90% probable service life for ball bearings).

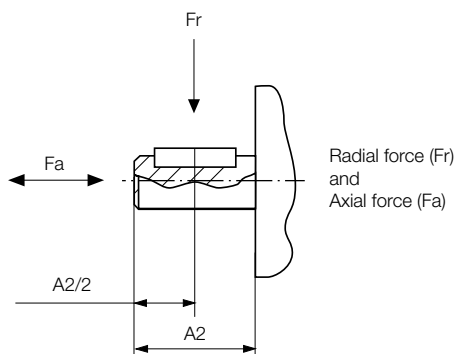

## Holding Brakes

Holding brakes are designed for the motors without gear box and can be ordered fully mounted on or added on later. The brake is fixed on the front of the motor.

Motor type	Order code	Brake torque Nm
P1V-A160A0900	<b>P1V-A/445709B</b>	*
P1V-A320A0700	<b>P1V-A/446196A</b>	*
P1V-A320D0300		*
P1V-A320B0140		*
P1V-A500A0600	<b>P1V-A/446062A</b>	*
P1V-A500D0300		*
P1V-A500B0145		*

\*) The braking torque is generally double the nominal torque.  
 The holding brake is not designed for use with a different drive system.  
 Please only use it in combination with the stated motor types.

For ATEX conformity, please contact Technical Sales.

## Dimensions (mm)

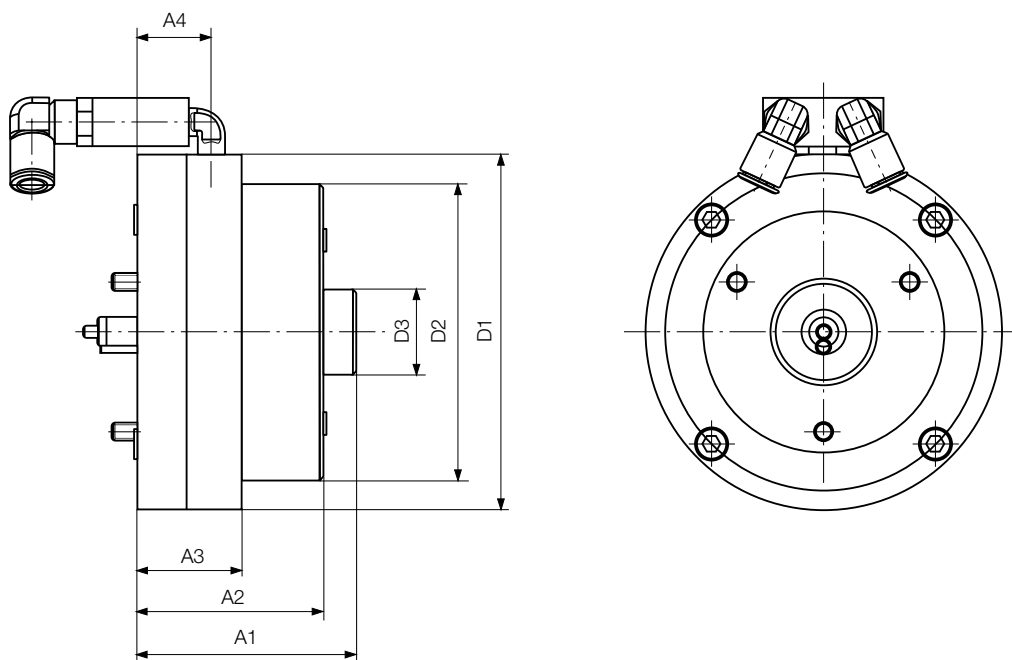

Order code	Dimensions of the braking device (mm)						
	A1	A2	A3	A4	D1	D2	D3
<b>P1V-A/445709B</b>	72.5	61.5	34.5	24.5	118	98	28
<b>P1V-A/445711B</b>	107	98	43.5	35.5	190	162	28
<b>P1V-A/445713B</b>	107	98	43.5	35.5	190	162	28



### P1V-A160A0900

**ATEX Ex II 2GD c IIC T3 (200°C) X**

#### Technical data

Max. power [Watt]	<b>1600</b>
Free speed [rpm]	9000
Nominal speed [rpm]	<b>4500</b>
Nominal torque [Nm]	<b>3,4</b>
Min. starting torque [Nm]	5,1
Stall torque [Nm]	6,5
Working pressure [bar]	3 to 7*
Air consumption [l/s]	31,7
Min pipe ID inlet/outlet [mm]	15 / 19
Connection [BSPP]	G1/2
Working temperature	-20° to +110°C -20 to +40°C in explosive atmosphere
Weight [kg]	5,2
Flange mounting	IEC71
Gear box type	None
Max. shaft radial force [N]	1000
Max. shaft axial force [N]	600
At A2/2 [mm]	15

\* 6 in explosive atmosphere

#### Torque & speed curves / Air Motor Power

— Torque in Nm at 6 bar    — Torque in Nm at 3 bar  
 — Power in W at 6 bar    — Power in W at 3 bar

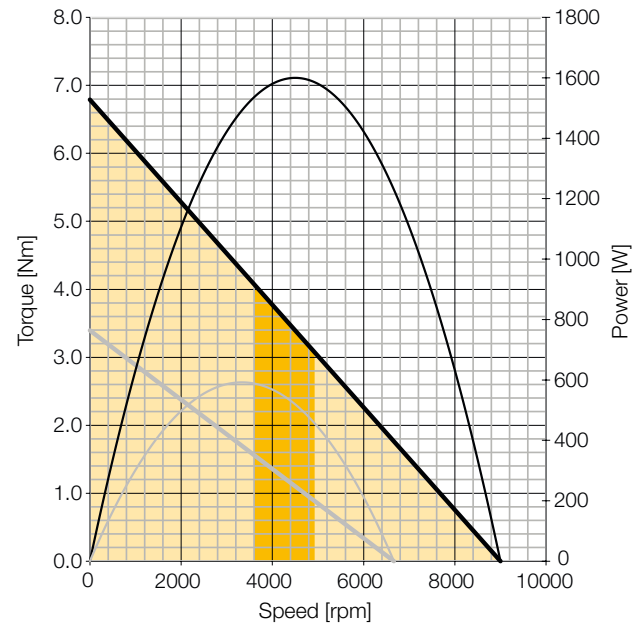

Optimum working speed range [rpm]    4500 to 3600  
 Optimum working torque range [Nm]    3,4 to 4,1

### P1V-A160D0300

**ATEX Ex II 2GD c IIC T3 (200°C) X**

#### Technical data

Max. power [Watt]	<b>1600</b>
Free speed [rpm]	3000
Nominal speed [rpm]	<b>1500</b>
Nominal torque [Nm]	<b>10,2</b>
Min. starting torque [Nm]	15,3
Stall torque [Nm]	19,4
Working pressure [bar]	3 to 7*
Air consumption [l/s]	31,7
Min pipe ID inlet/outlet [mm]	15 / 19
Connection [BSPP]	G1/2
Working temperature	-20° to +110°C -20 to +40°C in explosive atmosphere
Weight [kg]	9,5
Flange mounting	IEC80
Gear box type	Spur
Max. shaft radial force [N]	550
Max. shaft axial force [N]	1500
At A2/2 [mm]	20

\* 6 in explosive atmosphere

#### Torque & speed curves / Air Motor Power

— Torque in Nm at 6 bar    — Torque in Nm at 3 bar  
 — Power in W at 6 bar    — Power in W at 3 bar

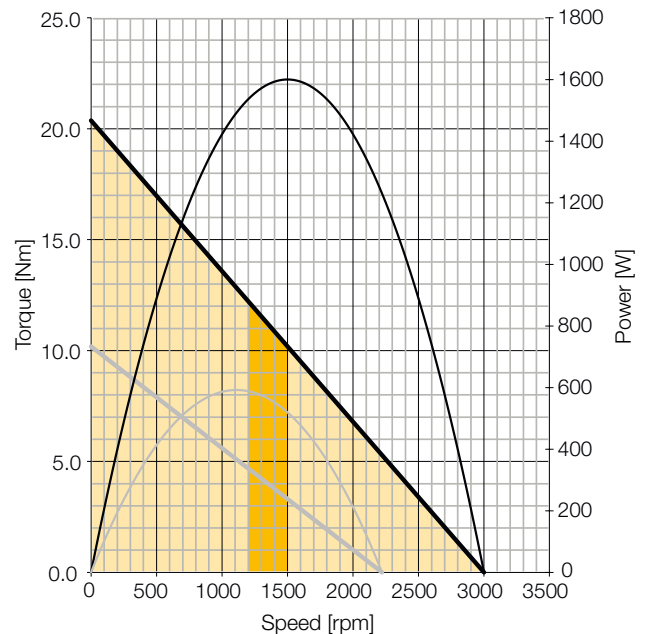

Optimum working speed range [rpm]    1500 to 1200  
 Optimum working torque range [Nm]    10,2 to 12,2

### P1V-A160B0140

**ATEX Ex II 2GD c IIC T3 (200°C) X**

#### Technical data

Max. power [Watt]	<b>1600</b>
Free speed [rpm]	1400
Nominal speed [rpm]	<b>700</b>
Nominal torque [Nm]	<b>21,8</b>
Min. starting torque [Nm]	32,7
Stall torque [Nm]	41,5
Working pressure [bar]	3 to 7*
Air consumption [l/s]	31,7
Min pipe ID inlet/outlet [mm]	15 / 19
Connection [BSPP]	G1/2
Working temperature	-20° to +110°C -20 to +40°C in explosive atmosphere
Weight [kg]	9,5
Flange mounting	IEC80
Gear box type	Planetary
Max. shaft radial force [N]	1200
Max. shaft axial force [N]	900
At A2/2 [mm]	20

\* 6 in explosive atmosphere

#### Torque & speed curves / Air Motor Power

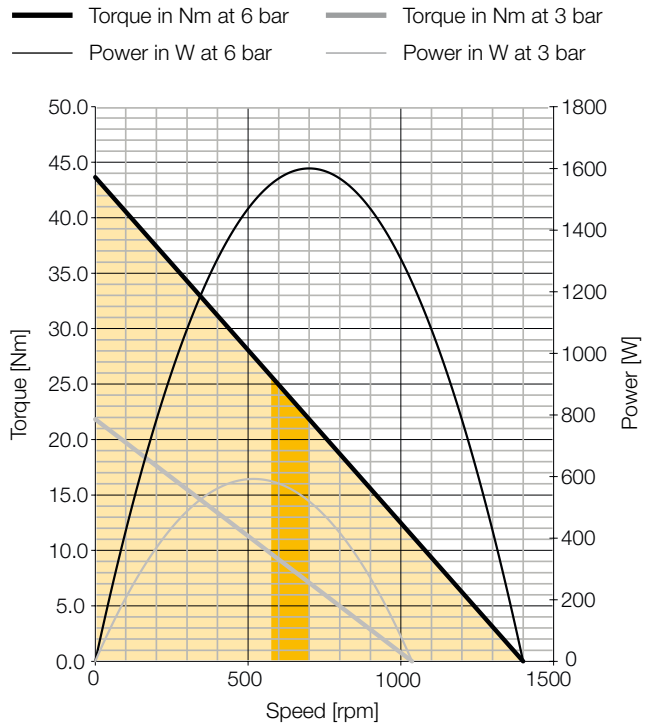

Optimum working speed range [rpm] 700 to 560  
 Optimum working torque range [Nm] 21,8 to 26,2

### P1V-A320A0700

**ATEX Ex II 2GD c IIC T3 (200°C) X**

#### Technical data

Max. power [Watt]	<b>3200</b>
Free speed [rpm]	7000
Nominal speed [rpm]	<b>3500</b>
Nominal torque [Nm]	<b>8,7</b>
Min. starting torque [Nm]	13,1
Stall torque [Nm]	16,6
Working pressure [bar]	3 to 7*
Air consumption [l/s]	65,0
Min pipe ID inlet/outlet [mm]	19 / 25
Connection [BSPP]	G3/4
Working temperature	-20° to +110°C -20 to +40°C in explosive atmosphere
Weight [kg]	10,3
Flange mounting	IEC80
Gear box type	None
Max. shaft radial force [N]	1400
Max. shaft axial force [N]	700
At A2/2 [mm]	20

\* 6 in explosive atmosphere

#### Torque & speed curves / Air Motor Power

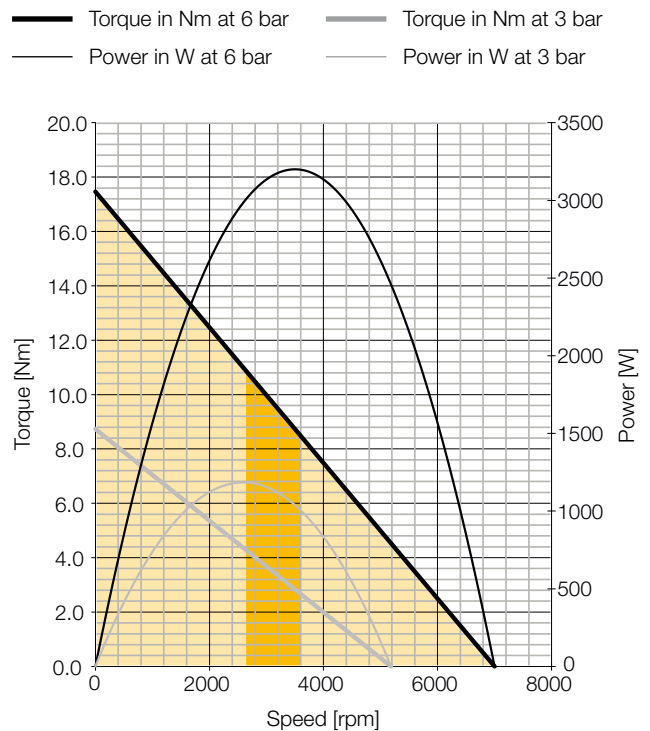

Optimum working speed range [rpm] 3500 to 2800  
 Optimum working torque range [Nm] 8,7 to 10,5

### P1V-A320D0300

**ATEX Ex II 2GD c IIC T3 (200°C) X**

#### Technical data

Max. power [Watt]	<b>3200</b>
Free speed [rpm]	3000
Nominal speed [rpm]	<b>1500</b>
Nominal torque [Nm]	<b>20,4</b>
Min. starting torque [Nm]	30,6
Stall torque [Nm]	38,7
Working pressure [bar]	3 to 7*
Air consumption [l/s]	65,0
Min pipe ID inlet/outlet [mm]	19 / 25
Connection [BSPP]	G3/4
Working temperature	-20° to +110°C -20 to +40°C in explosive atmosphere
Weight [kg]	15,4
Flange mounting	IEC90
Gear box type	Spur
Max. shaft radial force [N]	800
Max. shaft axial force [N]	1450
At A2/2 [mm]	25

\* 6 in explosive atmosphere

#### Torque & speed curves / Air Motor Power

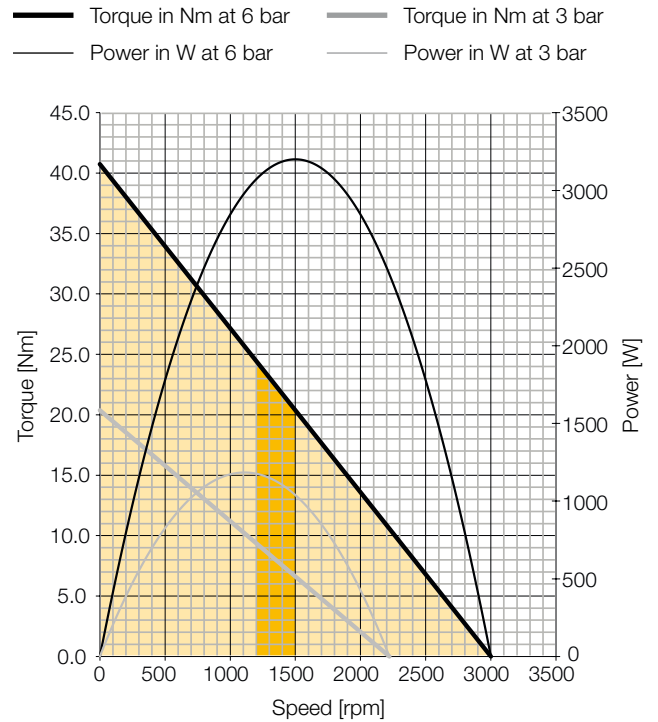

Optimum working speed range [rpm]      1500 to 1200  
 Optimum working torque range [Nm]      20,4 to 24,4

### P1V-A320B0140

**ATEX Ex II 2GD c IIC T3 (200°C) X**

#### Technical data

Max. power [Watt]	<b>3200</b>
Free speed [rpm]	1400
Nominal speed [rpm]	<b>700</b>
Nominal torque [Nm]	<b>43,7</b>
Min. starting torque [Nm]	65,5
Stall torque [Nm]	82,9
Working pressure [bar]	3 to 7*
Air consumption [l/s]	65,0
Min pipe ID inlet/outlet [mm]	19 / 25
Connection [BSPP]	G3/4
Working temperature	-20° to +110°C -20 to +40°C in explosive atmosphere
Weight [kg]	13,6
Flange mounting	IEC90
Gear box type	Helical
Max. shaft radial force [N]	1600
Max. shaft axial force [N]	1350
At A2/2 [mm]	25

\* 6 in explosive atmosphere

#### Torque & speed curves / Air Motor Power

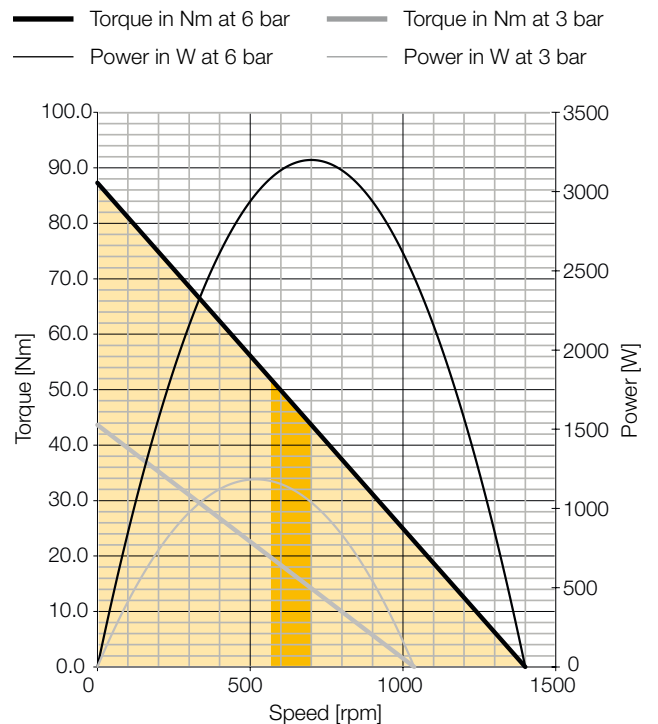

Optimum working speed range [rpm]      700 to 560  
 Optimum working torque range [Nm]      43,7 to 52,4

### P1V-A500A0600

**ATEX Ex II 2GD c IIC T3 (200°C) X**

#### Technical data

Max. power [Watt]	<b>5000</b>
Free speed [rpm]	6000
Nominal speed [rpm]	<b>3000</b>
Nominal torque [Nm]	<b>15,9</b>
Min. starting torque [Nm]	23,9
Stall torque [Nm]	30,2
Working pressure [bar]	3 to 7*
Air consumption [l/s]	96,7
Min pipe ID inlet/outlet [mm]	25 / 32
Connection [BSPP]	G1
Working temperature	-20° to +110°C -20 to +40°C in explosive atmosphere
Weight [kg]	17
Flange mounting	IEC90
Gear box type	None
Max. shaft radial force [N]	1900
Max. shaft axial force [N]	900
At A2/2 [mm]	25

\* 6 in explosive atmosphere

#### Torque & speed curves / Air Motor Power

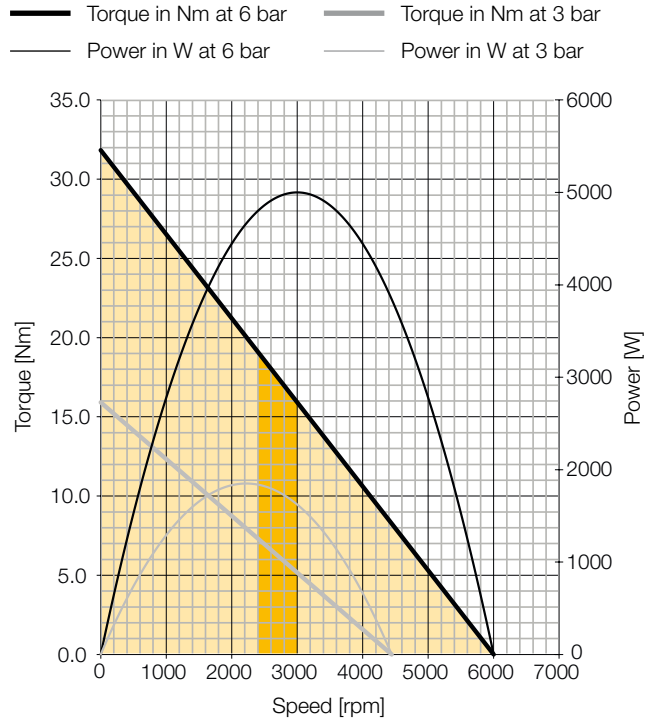

Optimum working speed range [rpm] 3000 to 2400  
 Optimum working torque range [Nm] 15,9 to 19,1

### P1V-A500D0300

**ATEX Ex II 2GD c IIC T3 (200°C) X**

#### Technical data

Max. power [Watt]	<b>5000</b>
Free speed [rpm]	3000
Nominal speed [rpm]	<b>1500</b>
Nominal torque [Nm]	<b>31,8</b>
Min. starting torque [Nm]	47,7
Stall torque [Nm]	60,5
Working pressure [bar]	3 to 7*
Air consumption [l/s]	96,7
Min pipe ID inlet/outlet [mm]	25 / 32
Connection [BSPP]	G1
Working temperature	-20° to +110°C -20 to +40°C in explosive atmosphere
Weight [kg]	25,8
Flange mounting	IEC100
Gear box type	Spur
Max. shaft radial force [N]	1250
Max. shaft axial force [N]	950
At A2/2 [mm]	30

\* 6 in explosive atmosphere

#### Torque & speed curves / Air Motor Power

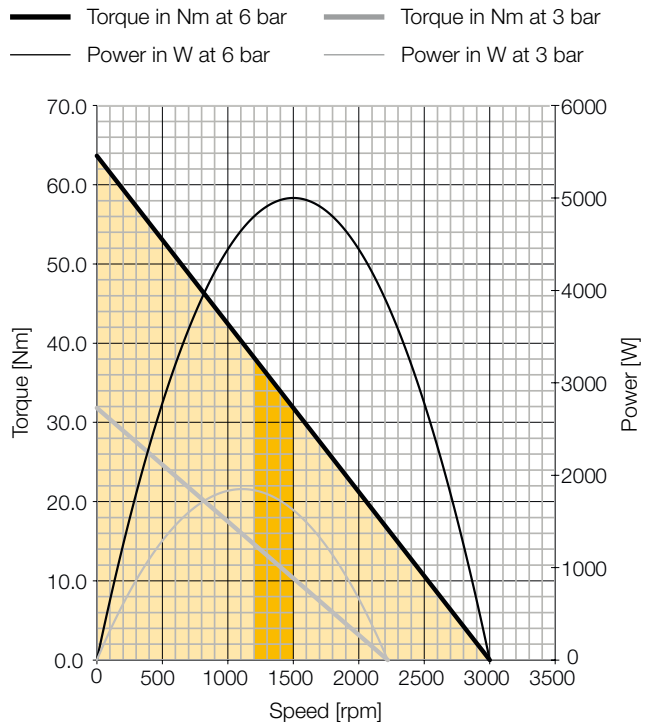

Optimum working speed range [rpm] 1500 to 1200  
 Optimum working torque range [Nm] 31,8 to 38,2

### P1V-A500B0145

**ATEX Ex II 2GD c IIC T3 (200°C) X**

#### Technical data

Max. power [Watt]	<b>5000</b>
Free speed [rpm]	1450
Nominal speed [rpm]	<b>725</b>
Nominal torque [Nm]	<b>65,9</b>
Min. starting torque [Nm]	98,8
Stall torque [Nm]	125,1
Working pressure [bar]	3 to 7*
Air consumption [l/s]	96,7
Min pipe ID inlet/outlet [mm]	25 / 32
Connection [BSPP]	G1
Working temperature	-20° to +110°C -20 to +40°C in explosive atmosphere
Weight [kg]	26,8
Flange mounting	IEC100
Gear box type	Helical
Max. shaft radial force [N]	2650
Max. shaft axial force [N]	1150
At A2/2 [mm]	30

\* 6 in explosive atmosphere

#### Torque & speed curves / Air Motor Power

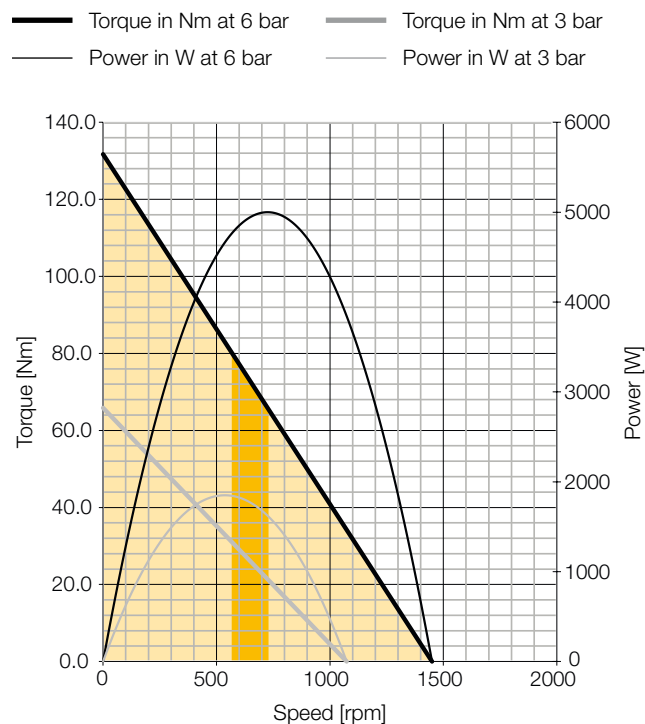

Optimum working speed range [rpm] 725 to 580  
 Optimum working torque range [Nm] 65,9 to 79,0

### P1V-A600A0700

**ATEX Ex II 2GD c IIC T3 (200°C) X**

#### Technical data

Max. power [Watt]	<b>6000</b>
Free speed [rpm]	7000
Nominal speed [rpm]	<b>3500</b>
Nominal torque [Nm]	<b>16,4</b>
Min. starting torque [Nm]	24,6
Stall torque [Nm]	31,1
Working pressure [bar]	3 to 7*
Air consumption [l/s]	131,7
Min pipe ID inlet/outlet [mm]	25 / 32
Connection [BSPP]	G1
Working temperature	-20° to +110°C -20 to +40°C in explosive atmosphere
Weight [kg]	17,0
Flange mounting	IEC90
Gear box type	None
Max. shaft radial force [N]	1900
Max. shaft axial force [N]	900
At A2/2 [mm]	25

\* 6 in explosive atmosphere

#### Torque & speed curves / Air Motor Power

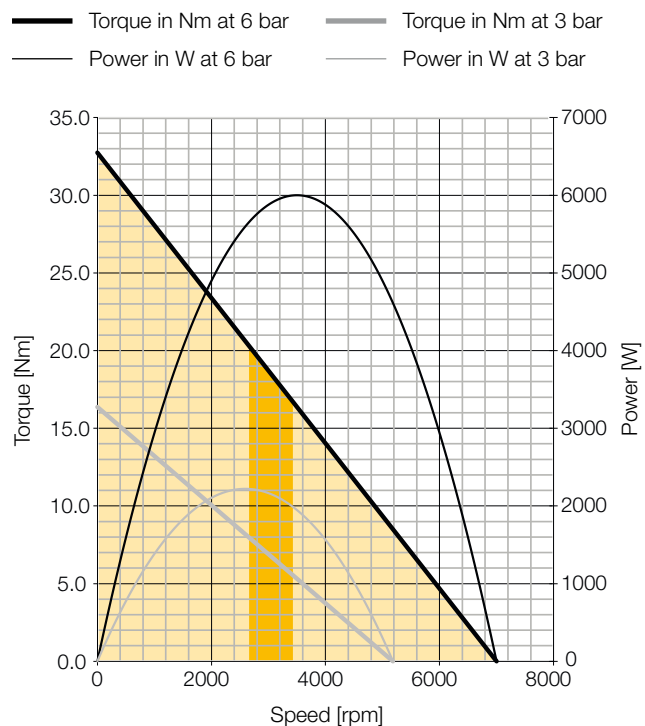

Optimum working speed range [rpm] 3500 to 2800  
 Optimum working torque range [Nm] 16,4 to 19,6

### P1V-A600D0350

**ATEX Ex II 2GD c IIC T3 (200°C) X**

#### Technical data

Max. power [Watt]	<b>6000</b>
Free speed [rpm]	3500
Nominal speed [rpm]	<b>1750</b>
Nominal torque [Nm]	<b>32,7</b>
Min. starting torque [Nm]	49,1
Stall torque [Nm]	62,2
Working pressure [bar]	3 to 7*
Air consumption [l/s]	131,7
Min pipe ID inlet/outlet [mm]	25 / 32
Connection [BSPP]	G1
Working temperature	-20° to +110°C -20 to +40°C in explosive atmosphere
Weight [kg]	25,8
Flange mounting	IEC100
Gear box type	Spur
Max. shaft radial force [N]	1250
Max. shaft axial force [N]	880
At A2/2 [mm]	30

\* 6 in explosive atmosphere

#### Torque & speed curves / Air Motor Power

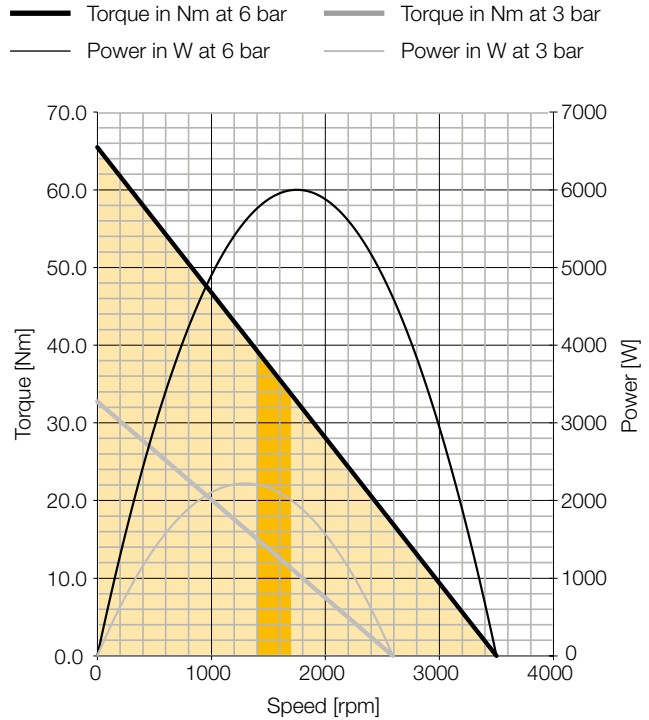

Optimum working speed range [rpm] 1750 to 1400

Optimum working torque range [Nm] 32,7 to 39,3

### P1V-A600B0160

**ATEX Ex II 2GD c IIC T3 (200°C) X**

#### Technical data

Max. power [Watt]	<b>6000</b>
Free speed [rpm]	1600
Nominal speed [rpm]	<b>800</b>
Nominal torque [Nm]	<b>71,6</b>
Min. starting torque [Nm]	107,4
Stall torque [Nm]	136.1
Working pressure [bar]	3 to 7*
Air consumption [l/s]	131,7
Min pipe ID inlet/outlet [mm]	25 / 32
Connection [BSPP]	G1
Working temperature	-20° to +110°C -20 to +40°C in explosive atmosphere
Weight [kg]	26,8
Flange mounting	IEC100
Gear box type	Helical
Max. shaft radial force [N]	2650
Max. shaft axial force [N]	1150
At A2/2 [mm]	30

\* 6 in explosive atmosphere

#### Torque & speed curves / Air Motor Power

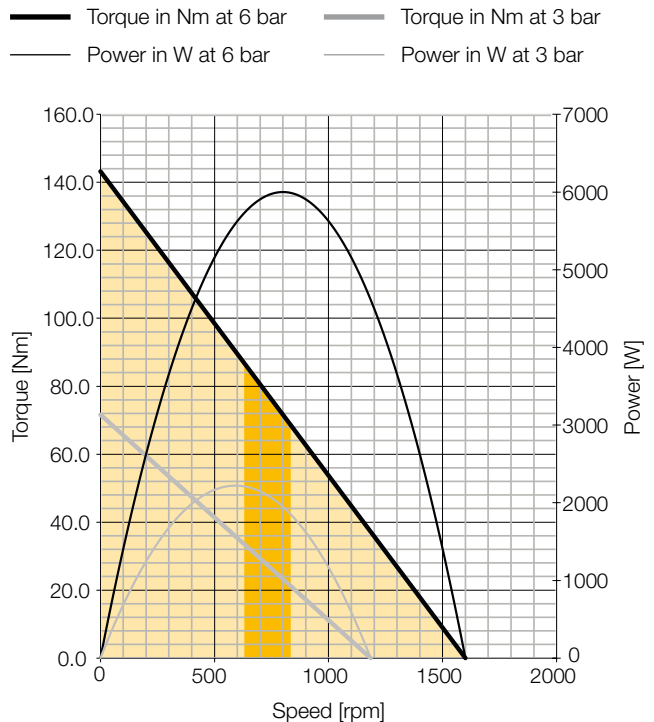

Optimum working speed range [rpm] 800 to 640

Optimum working torque range [Nm] 71,6 to 85,9

### P1V-A900A0600

#### Technical data

Max. power [Watt]	<b>18000</b>
Free speed [rpm]	6000
Nominal speed [rpm]	<b>3000</b>
Nominal torque [Nm]	<b>28,6</b>
Min. starting torque [Nm]	43,0
Stall torque [Nm]	54,4
Working pressure [bar]	3 to 7*
Air consumption [l/s]	166,7
Min pipe ID inlet/outlet [mm]	25 / 32
Connection [BSPP]	G1
Working temperature	-20° to +110°C
Weight [kg]	33
Flange mounting	IEC112A
Gear box type	None
Max. shaft radial force [N]	7500
Max. shaft axial force [N]	1100
At A2/2 [mm]	30

\* 6 in explosive atmosphere

#### Torque & speed curves / Air Motor Power

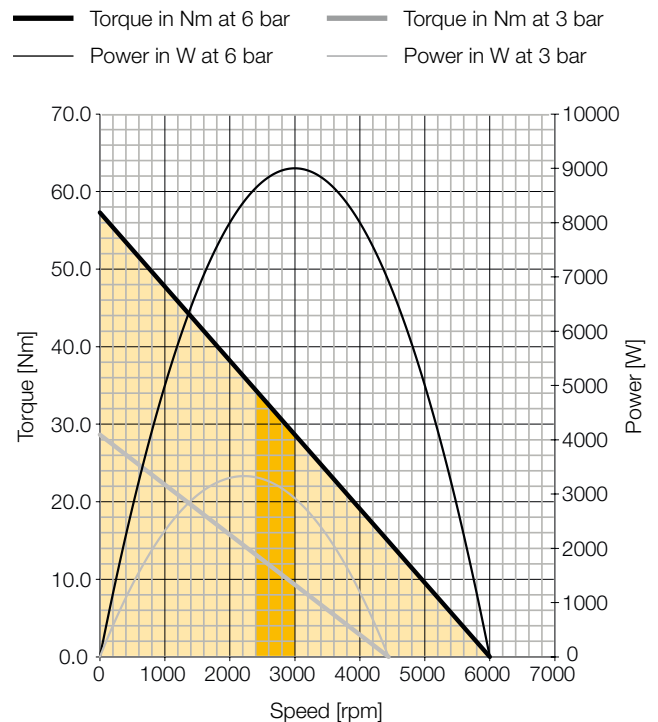

Optimum working speed range [rpm] 3000 to 2400  
 Optimum working torque range [Nm] 28,6 to 34,4

### P1V-AJ00A0600

#### Technical data

Max. power [Watt]	<b>18000</b>
Free speed [rpm]	6000
Nominal speed [rpm]	<b>3000</b>
Nominal torque [Nm]	<b>57,3</b>
Min. starting torque [Nm]	85,9
Stall torque [Nm]	108,9
Working pressure [bar]	3 to 7*
Air consumption [l/s]	333,3
Min pipe ID inlet/outlet [mm]	43 / 63,5
Connection [BSPP]	G2
Working temperature	-20° to +110°C
Weight [kg]	54,0
Flange mounting	IEC112A
Gear box type	None
Max. shaft radial force [N]	7500
Max. shaft axial force [N]	1100
At A2/2 [mm]	30

\* 6 in explosive atmosphere

#### Torque & speed curves / Air Motor Power

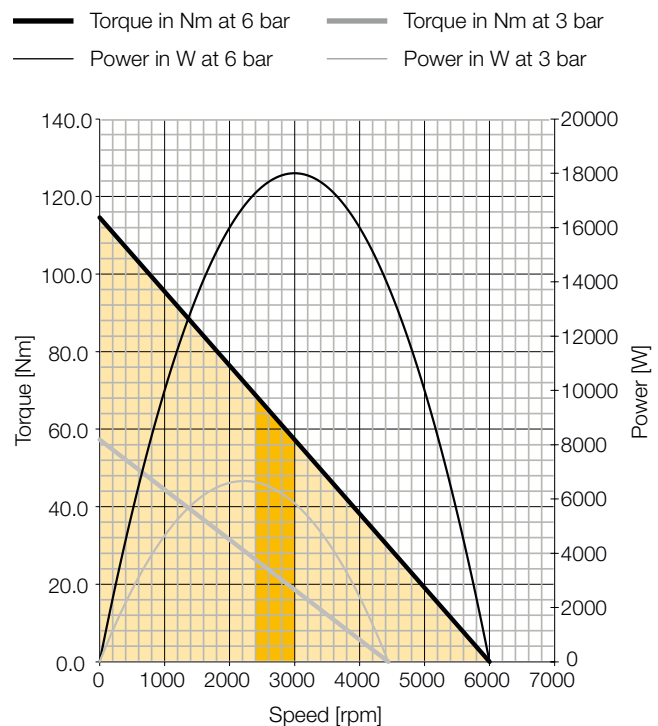

Optimum working speed range [rpm] 3000 to 2400  
 Optimum working torque range [Nm] 57,3 to 68,8

**P1V-A160A0900**

**IEC71 Flange mounting**

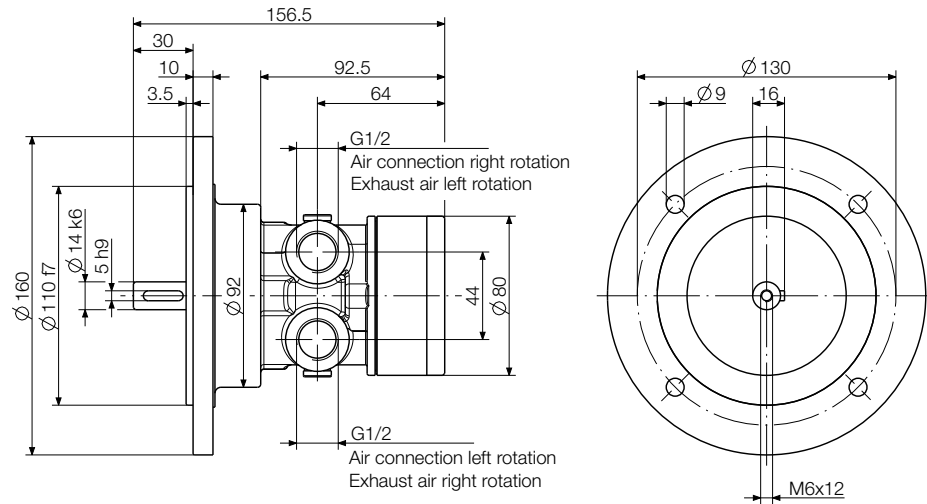

**P1V-A160D0300**

**IEC80 Flange mounting**

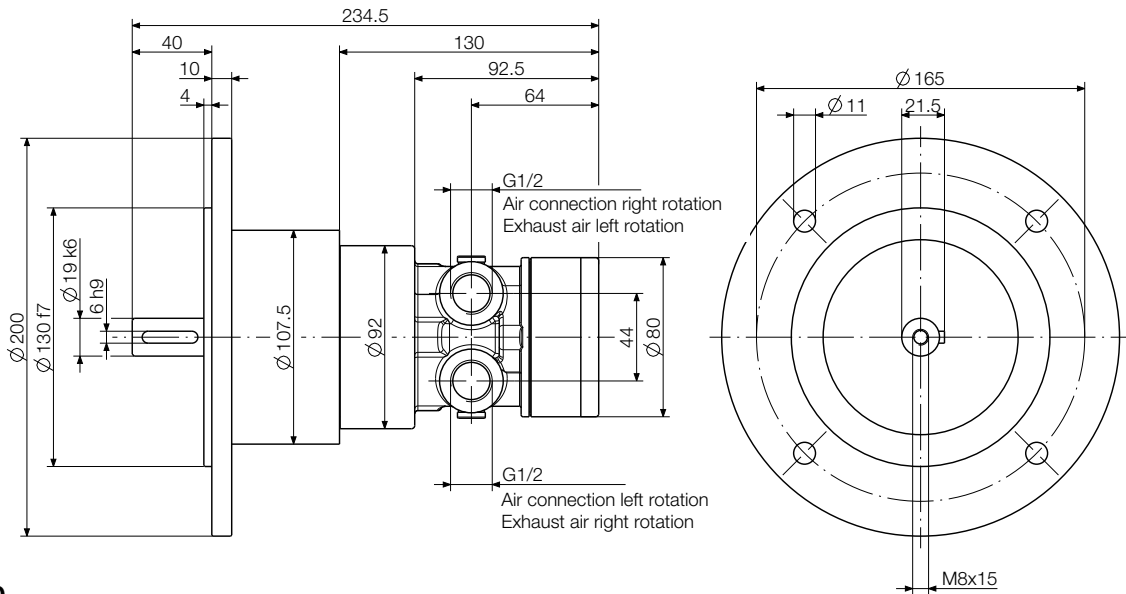

**P1V-A160B0140**

**IEC80 Flange mounting**

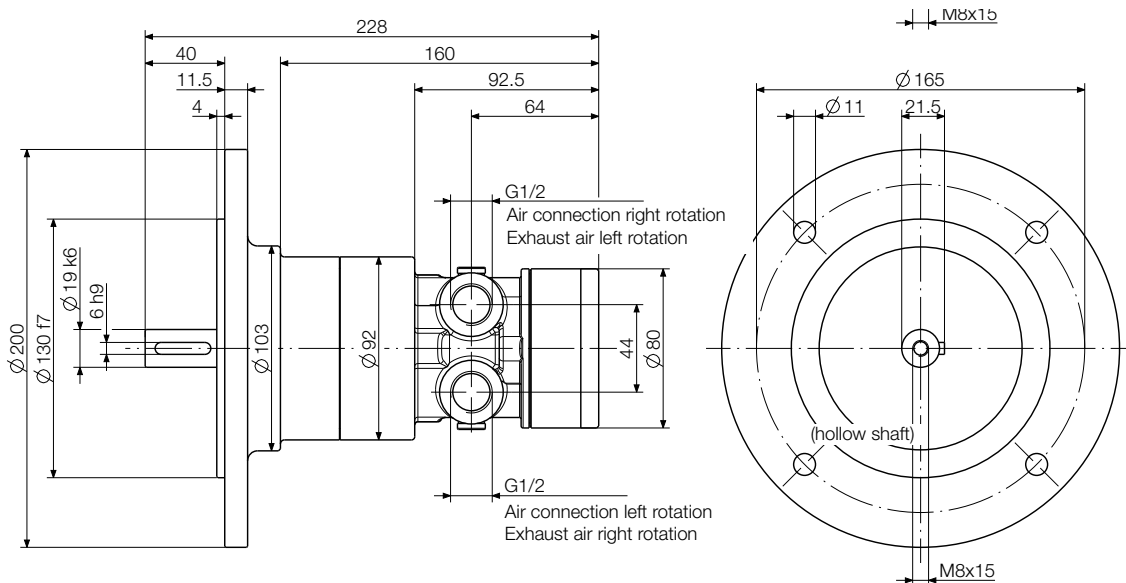

Dimensions in mm



**P1V-A320A0700**  
**IEC80 Flange mounting**

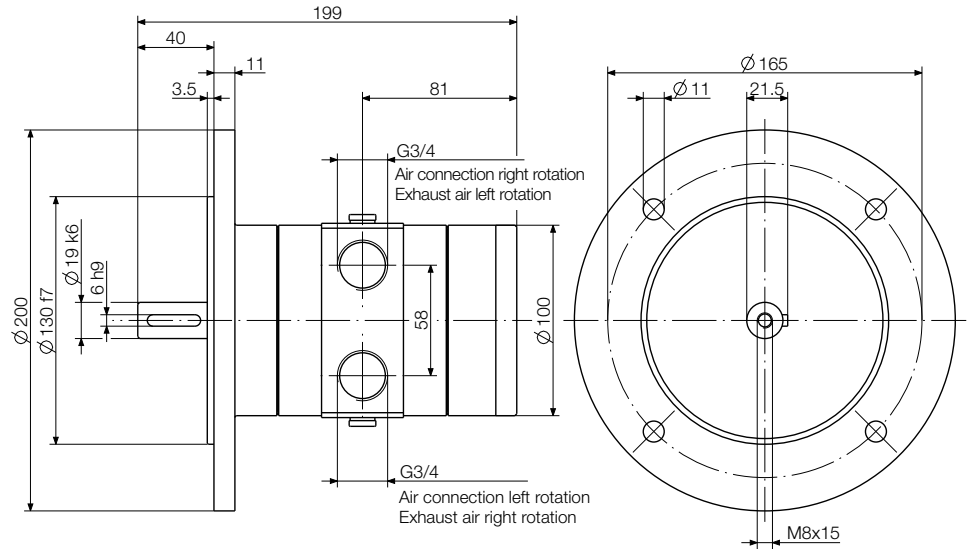

**P1V-A320D0300**  
**IEC90 Flange mounting**

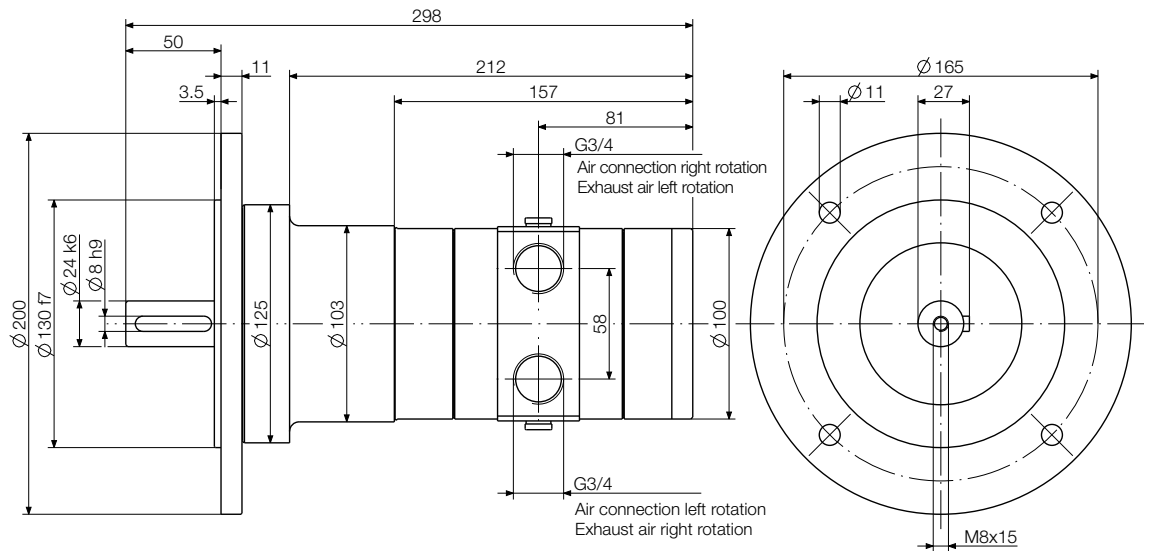

**P1V-A320B0140**  
**IEC90 Flange mounting**

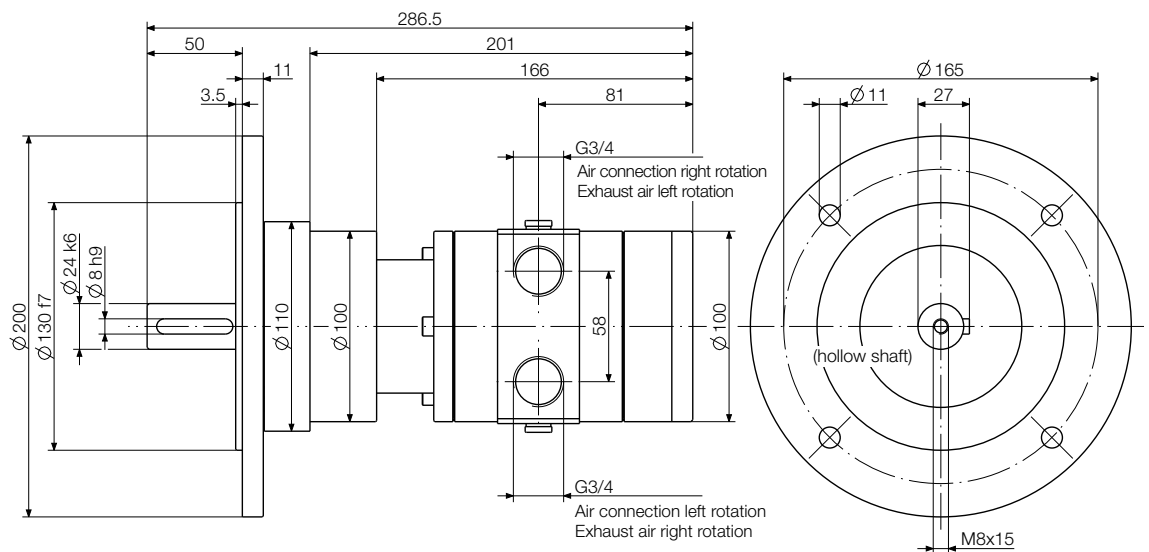

Dimensions in mm

**P1V-A500A0600**

**IEC90 Flange mounting**

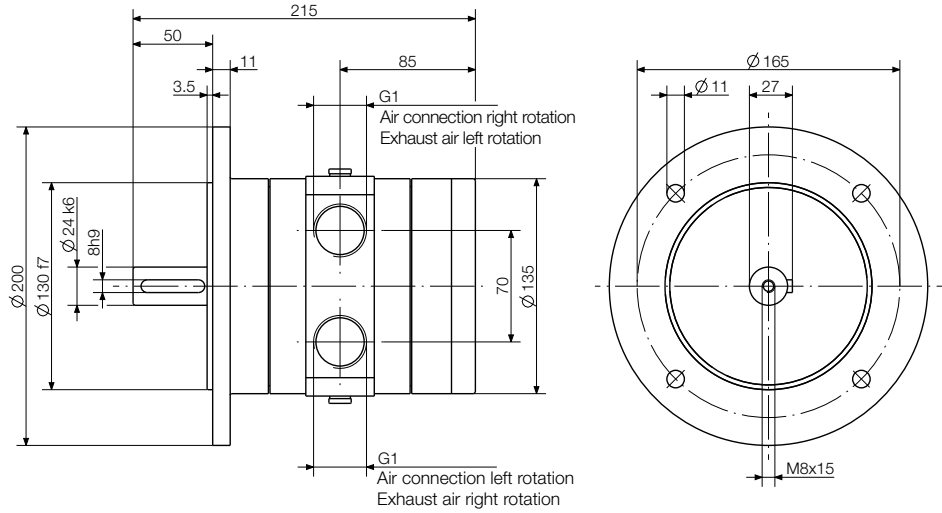

**P1V-A500D0300**

**IEC100 Flange mounting**

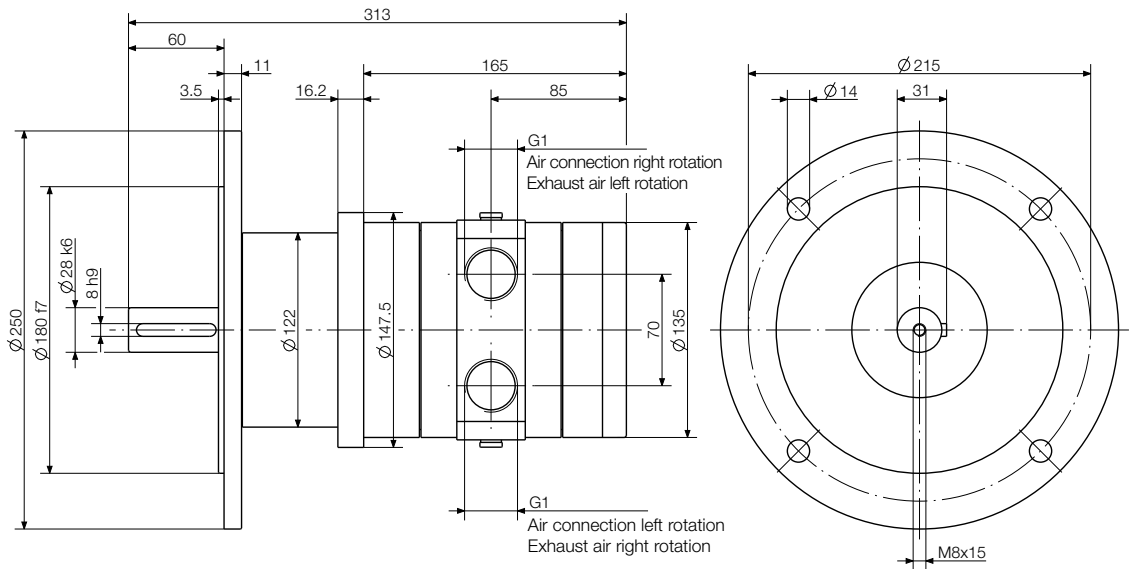

**P1V-A500B0145**

**IEC100 Flange mounting**

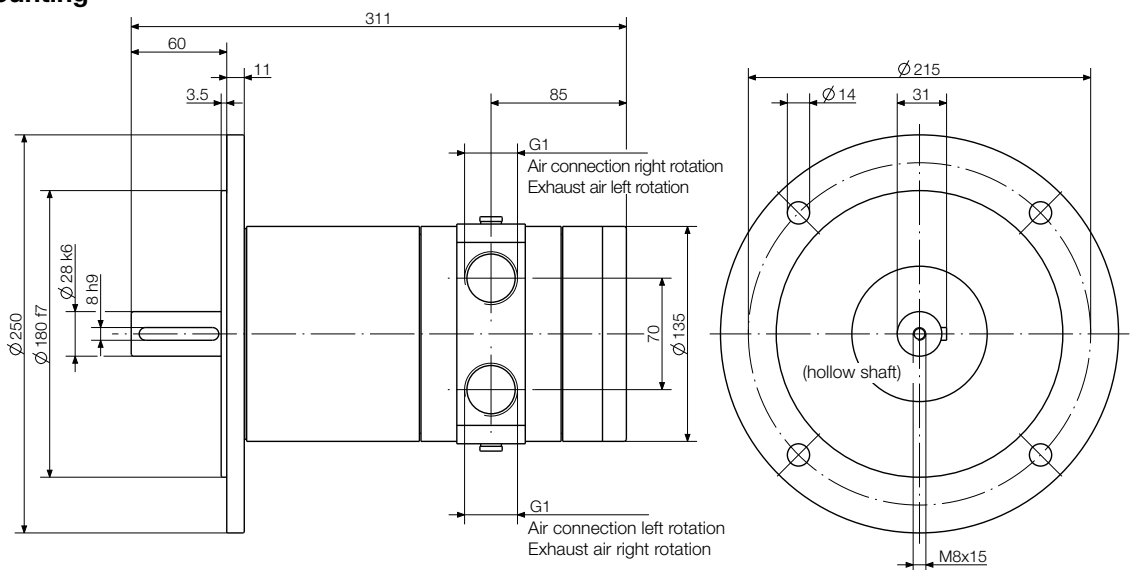

Dimensions in mm

**P1V-A600A0700**  
**IEC90 Flange mounting**

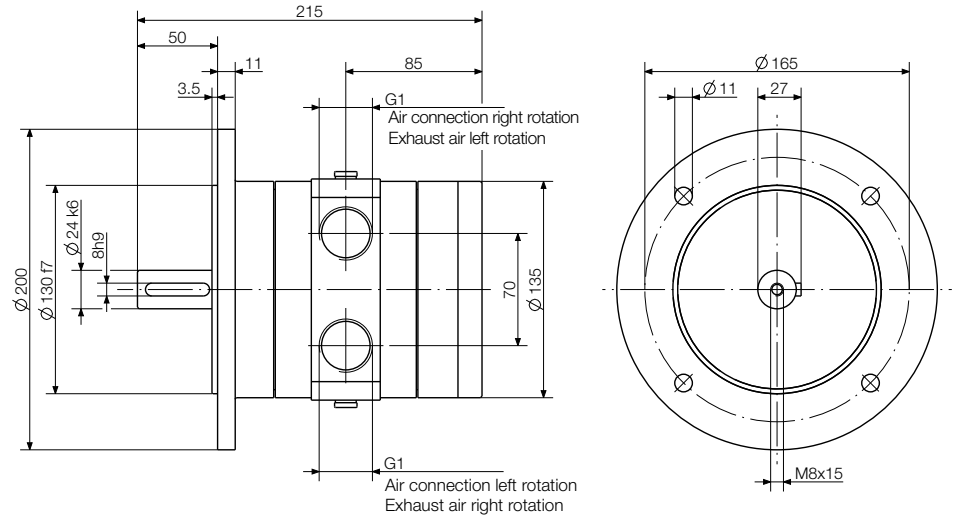

**P1V-A600D0350**  
**IEC100 Flange mounting**

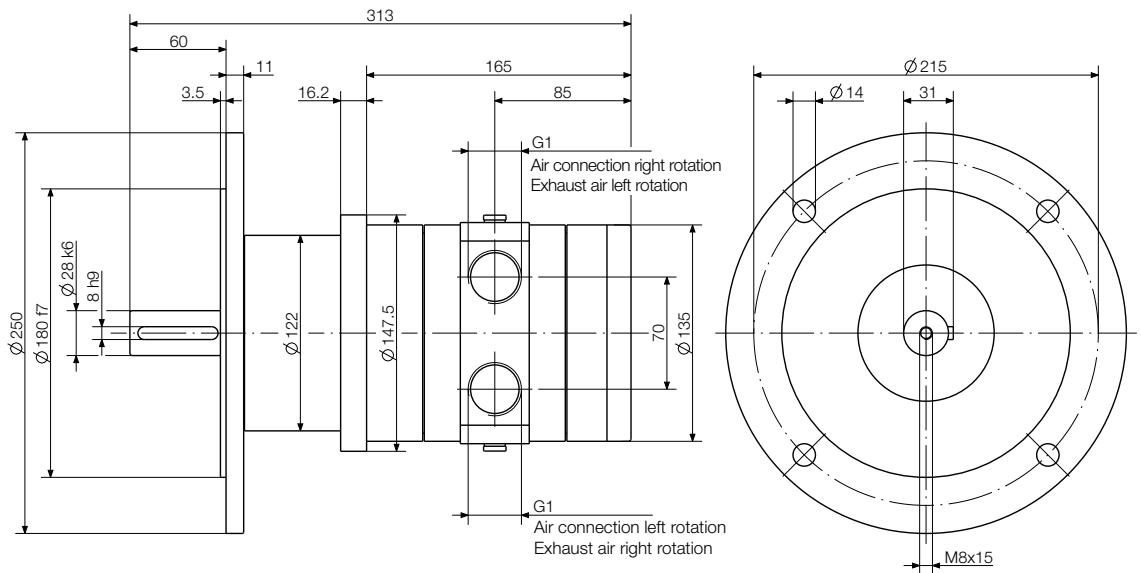

**P1V-A600B0160**  
**IEC100 Flange mounting**

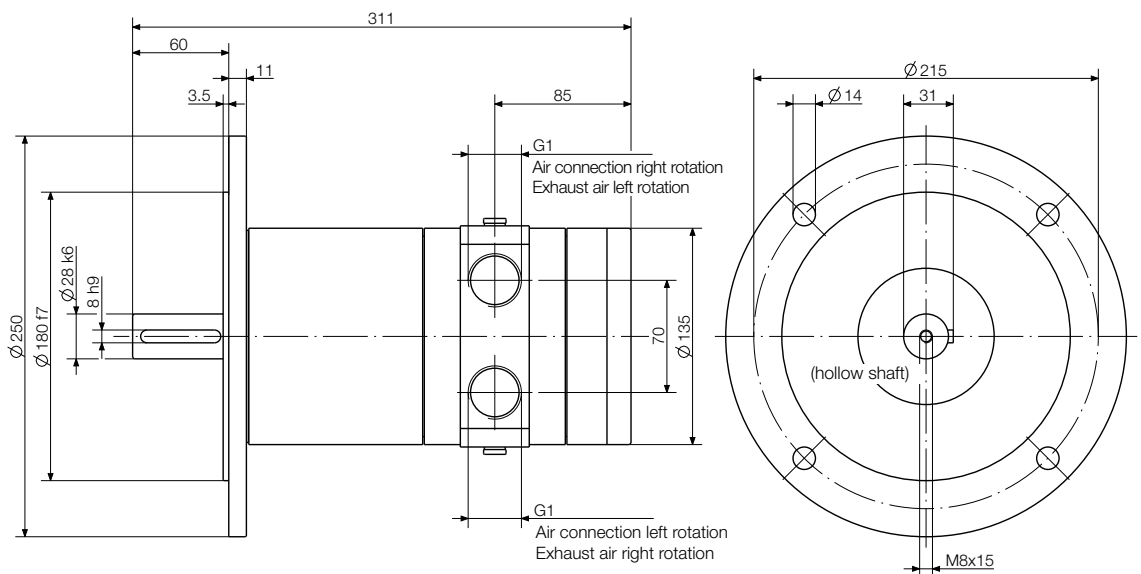

Dimensions in mm

**P1V-A900A0600**  
**IEC112A Flange mounting**

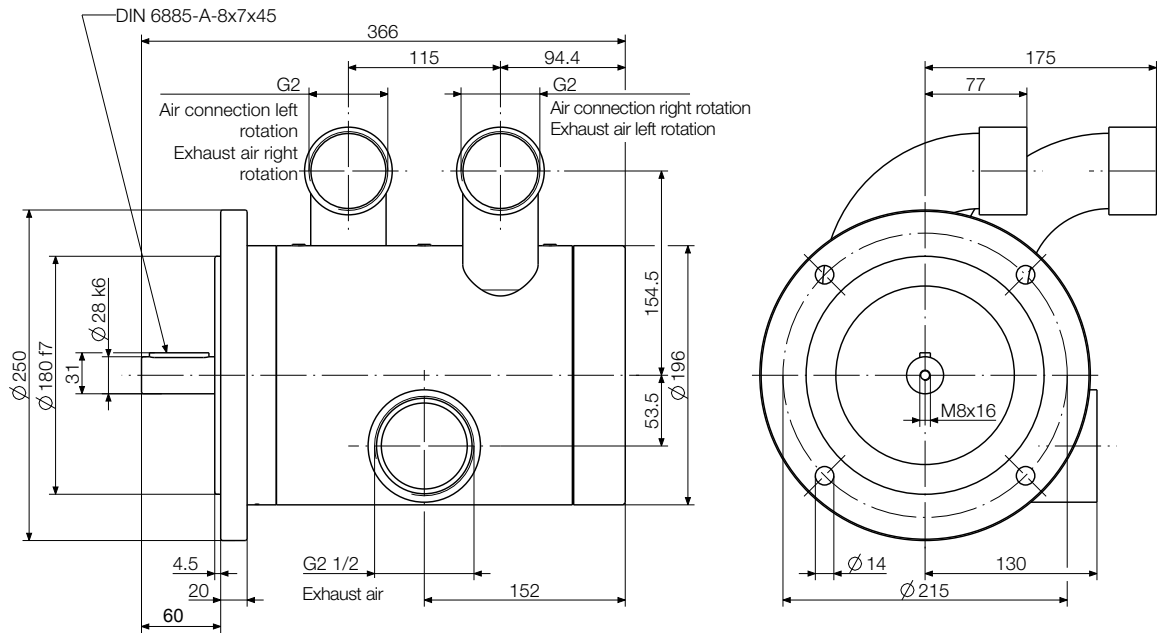
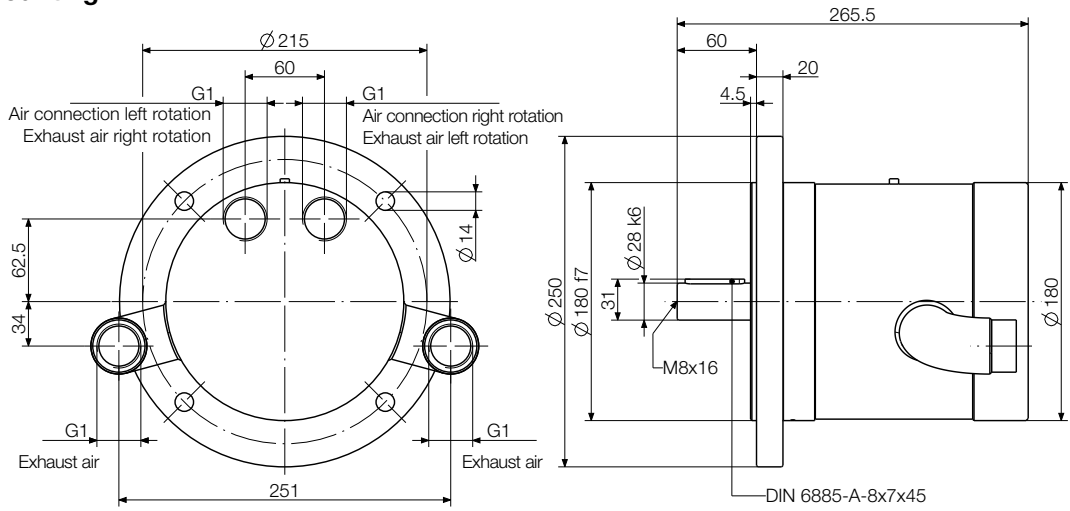

**P1V-AF1 Foot bracket**

Made in steel, kit with mounting screws

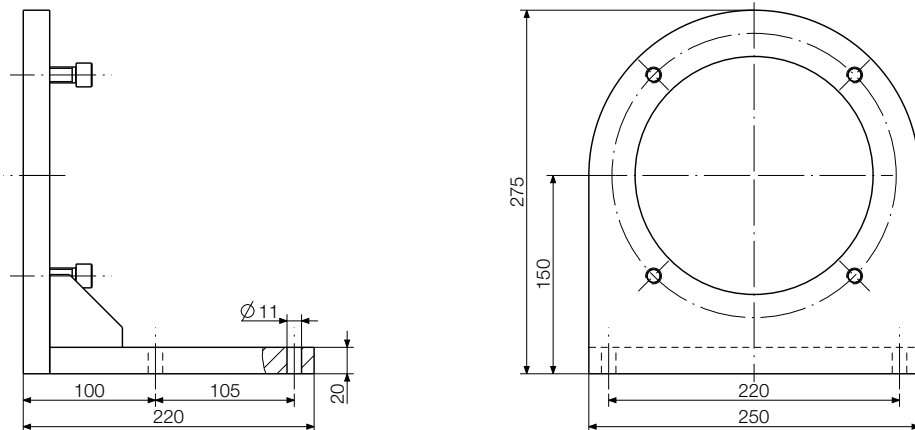

Dimensions in mm



## Choice of an air motor with gear

**Planetary gears** are characterized by high efficiency, low moment of inertia and can offer high gear ratios.

**Helical gears** are characterized by high efficiency. Several reduction stages permit relatively high gear ratios. Central output shaft and simple installation with flange or foot.

**Worm gears** are characterized by relatively simple technical construction, with a worm and pinion. This can give a large gear ratio and small dimensions. The efficiency of a worm drive gear is considerably lower than for planetary or helical gears.

### Planetary Gear

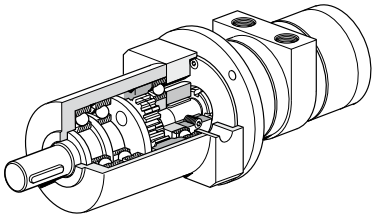

The output shaft is always in the middle of the gearbox. Small installation dimensions relative to the torque provided. The gears are lubricated by grease, which means that it can be installed in all conceivable positions.

- Small installation dimensions
- Free installation position
- Simple flange installation
- Low weight
- Output shaft in the middle
- High efficiency

### Helical (Spur) Gear

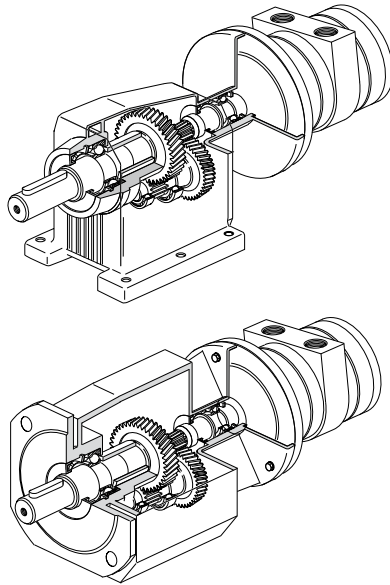

Oil-bath gearboxes mean that the installation position must be decided in advance. The installation position determines the volume of oil in the gearbox and location of oil filling and drain plugs.

- High efficiency
- Simple flange or foot installation
- Relatively low price
  - Installation position must be chosen in advance
  - Higher weight than planetary or worm drive gears.

### Worm Gear

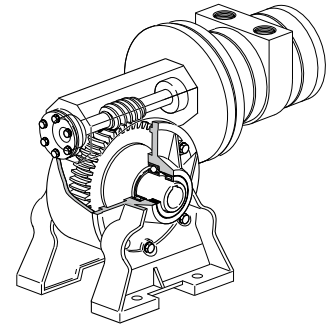

The design principle of worm drive gears makes them self-locking at higher gear ratios (the output shaft is "locked"). The output shaft comes out at an angle of 90° to the motor spindle. Installation is simple, with a flange on the left or right side, or with a foot. The gearbox is equipped as standard with a hollow output shaft with a key slot. Loose shafts with key can put the output shaft on the right, left, or on both sides. Oil-bath gearboxes mean that the installation position must be decided in advance. The installation position determines the volume of oil in the gearbox and location of oil filling and drain plugs.

- Low weight in relation to gear ratio
- Non-reversible at high gear ratios
- Relatively low price
  - Relatively low efficiency
  - Installation position must be decided in advance
  - Output shaft at 90° to motor spindle

## Choice of an air motor with a gear

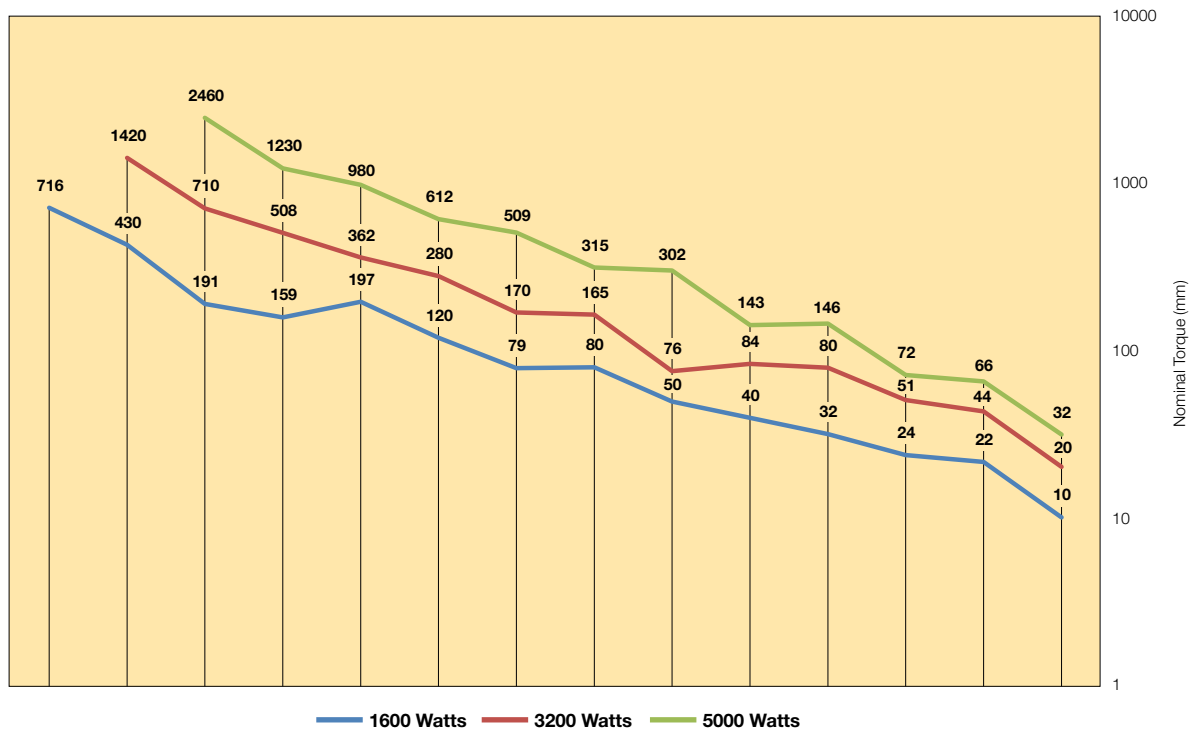

The motor to be used should be selected by starting with the torque needed at a specific spindle speed. In other words, to choose the right motor, you have to know the required speed and torque. Since maximum power is reached at half the motor's free speed, the motor should be chosen so that the point aimed at is as close as possible to the maximum power of the motor.

The design principle of the motor means that higher torque is generated when it is braked, which tends to increase the speed, etc. This means that the motor has a kind of speed self regulation function built in.

Use the following graph to choose the correct motor size and the correct type of gear as appropriate. The graph contains the points for the maximum torque of each motor at maximum power. Put in your point on the graph and select a marked point above and to the right of the point you need.

Then check the characteristic graph of each motor to find more accurate technical data. Always select a motor where the data required is in the grey field. Also use the correction diagram to see what it would mean to use different air supply pressures with the motor.

**Tip:** Select a motor which is slightly too fast and powerful, regulate its speed and torque with a pressure regulator and/or restriction to achieve the optimum working point.

Order code	Gear box type	Torque (Nm)	Order code	Gear box type	Torque (Nm)	Order code	Gear box type	Torque (Nm)	Order code	Gear box type	Torque (Nm)
P1V-A160D0300	Helical (spur)	10	P1V-A320D0300	Helical (spur)	20	P1V-A500D0300	Helical (spur)	32	P1V-A600D0350	Helical (spur)	33
P1V-A160B0140	Planetary	22	P1V-A320B0140	Planetary	44	P1V-A500B0145	Planetary	66	P1V-A600B0160	Planetary	72
P1V-A160D0066**	Helical (spur)	24	P1V-A320D0080**	Helical (spur)	51	P1V-A500D0105**	Helical (spur)	72			
P1V-A160B0060	Planetary	32	P1V-A320D0052**	Helical (spur)	80	P1V-A500D0052**	Helical (spur)	146			
P1V-A160H0043**	Worm	40	P1V-A320B0060	Planetary	84	P1V-A500H0050**	Worm	143			
P1V-A160D0032**	Helical (spur)	50	P1V-A320H0050**	Worm	76	P1V-A500D0025**	Helical (spur)	302			
P1V-A160B0019	Planetary	80	P1V-A320D0025**	Helical (spur)	165	P1V-A500H0022**	Worm	315			
P1V-A160H0020**	Worm	79	P1V-A320H0022**	Worm	170	P1V-A500H0013**	Worm	509			
P1V-A160D0014**	Helical (spur)	120	P1V-A320H0013**	Worm	280	P1V-A500D0013**	Helical (spur)	612			
P1V-A160D0008**	Helical (spur)	197	P1V-A320D0011**	Helical (spur)	362	P1V-A500H0006**	Worm	980			
P1V-A160H0010**	Worm	159	P1V-A320H0006**	Worm	508	P1V-A500D0006**	Helical (spur)	1230			
P1V-A160H0008**	Worm	191	P1V-A320H0006**	Helical (spur)	710	P1V-A500H0003**	Helical (spur)	2460			
P1V-A160D0004**	Helical (spur)	430	P1V-A320D0003**	Helical (spur)	1420						
P1V-A160D0003**	Helical (spur)	716									

**Note!** All technical data are based on a working pressure of 6 bar and with oil.  
Speed tolerance accuracy is  $\pm 10\%$ .

**For ATEX conformity, please contact Technical Sales**



**Note!** Inlet and exhaust air flows are critical for reaching the best performances.

**B: Reversible motor with planetary gear box, flange (B) mounting, free installation position**

Max power	Free speed	Nominal speed	Nominal torque	Min starting torque	Max gear box permanent torque	Air consumption	Connection	Min pipe ID	Weight	Mounting	Max permissible shaft loading		At A2/2	Gear box type & size	Order code
											F radial (N)	F axial (N)			
Watt	rpm	rpm	Nm	Nm	Nm	l/s	BSP	mm	kg			mm			
1600	600	450	32.0	48.0	<b>35.0</b>	31.7	G1/2	15/19	8.3	Flange	2400	1900	23.0	P90F	<b>P1V-A160B0060</b>
1600	190	180	80.0	120.0	<b>100.0</b>	31.7	G1/2	15/19	15.4	Flange	4600	4000	35.0	P120F	<b>P1V-A160B0019</b>
3200	600	350	84.0 *	131.0	<b>40.0</b>	65.0	G3/4	19/25	14.3	Flange	2400	1900	23.0	P90F	<b>P1V-A320B0060</b>

Maximum admissible speed (idling)  
Air consumption at the maximum air motor power  
\* Maximum torque 480 Nm for a maximum of 1000 cycles under load.

**Permitted shaft loadings**

Max permitted load on output shaft for basic motors (based on 10,000,000 revolutions of the output shaft, with 90% probable service life for ball bearings).

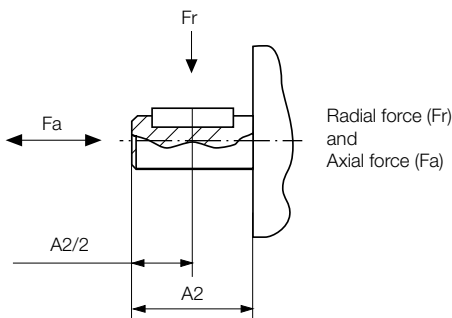



**P1V-A160B0060 planetary gear box (B)**

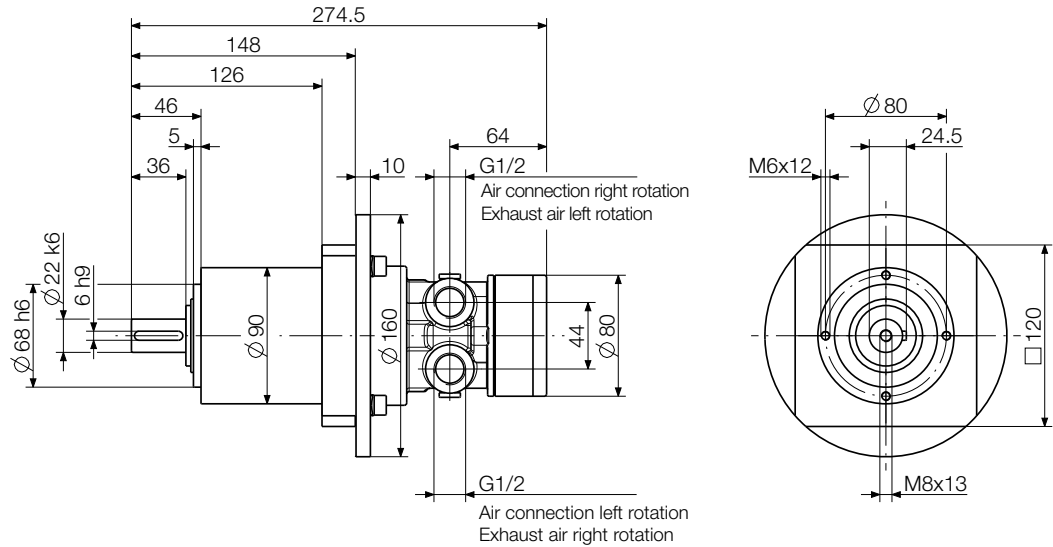

**P1V-A160B0019 planetary gear box (B)**

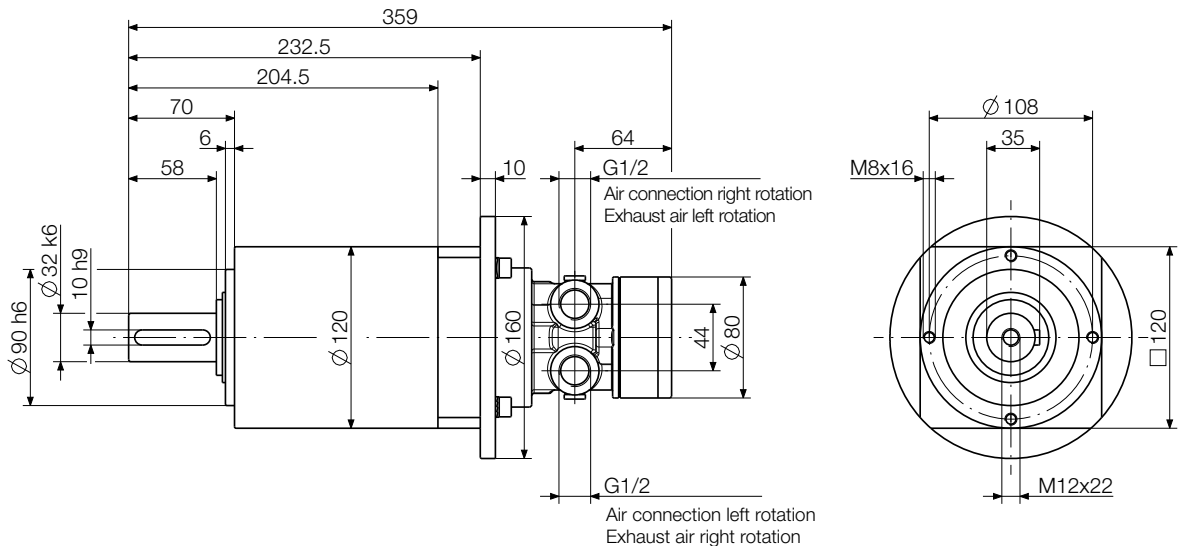

**P1V-A320B0060 planetary gear box (D)**

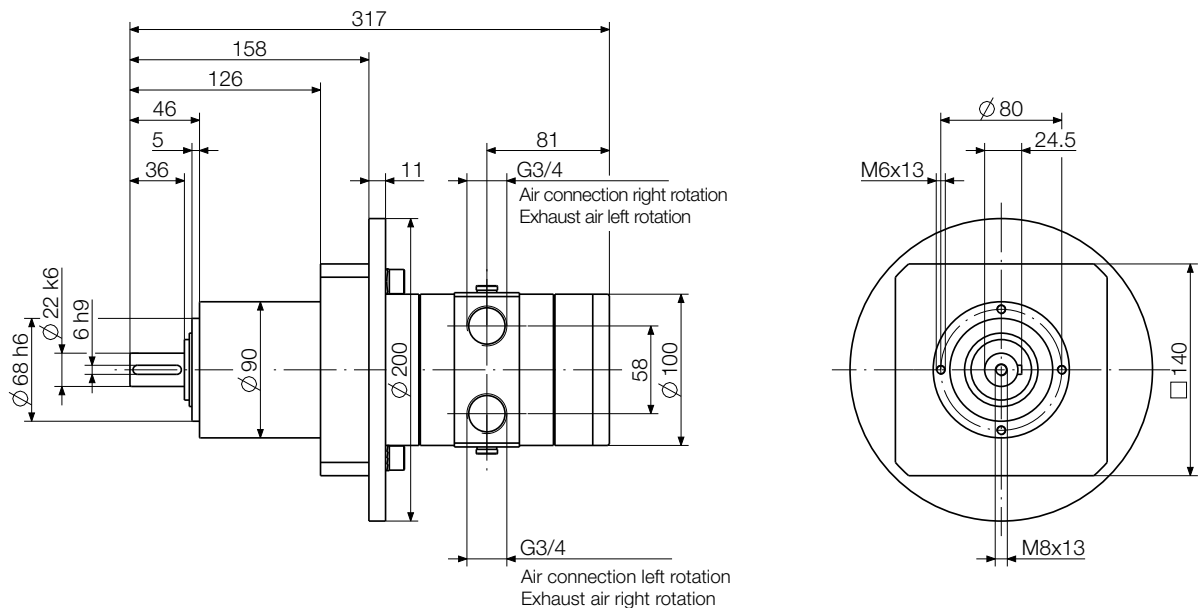

Dimensions in mm

**Note!** All technical data are based on a working pressure of 6 bar and with oil.  
Speed tolerance accuracy is +-10%.

For ATEX conformity, please contact Technical Sales

**Note!** Inlet and exhaust air flows are critical for reaching the best performances.

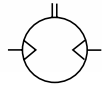
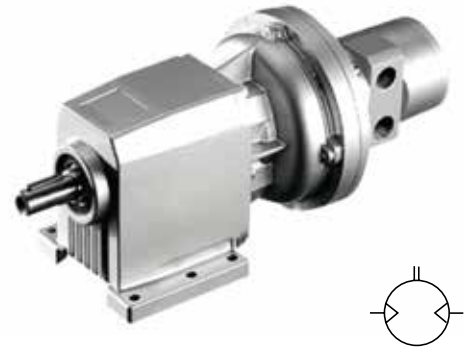

**D, E: Reversible motor with helical (spur) gear box, flange (D) or foot bracket (E) mountings**

Max power	Free speed	Nominal speed	Nominal torque	Min starting torque	Max gear box permanent torque	Air consumption	Connection	Min pipe ID inlet/outlet	Weight	Max permissible shaft loading	At B3/2	Mounting	Gear box type & size	Order code	Mounting	Gear box type & size	Order code	
Watt	rpm	rpm	Nm	Nm		l/s	BSP	mm	kg	F radial (N)	F axial (N)	mm						
1600	660	590	24.0	36.0	45.0	31.7	G1/2	15/19	11.2	1140	228	20	Flange	S122F	P1V-A160D0066	Foot	S122K	P1V-A160E0066
1600	320	280	50.0	75.0	140.0	31.7	G1/2	15/19	12.2	2030	406	25	Flange	S222F	P1V-A160D0032	Foot	S222K	P1V-A160E0032
1600	140	120	120.0	180.0	280.0	31.7	G1/2	15/19	14.4	4030	806	30	Flange	S322F	P1V-A160D0014	Foot	S322K	P1V-A160E0014
1600	80	70	197.0	299.0	560.0	31.7	G1/2	15/19	32.2	5800	1160	35	Flange	S413F	P1V-A160D0008	Foot	S413K	P1V-A160E0008
1600	37	33	430.0	645.0	1000.0	31.7	G1/2	15/19	53.4	10000	2000	40	Flange	S513F	P1V-A160D0004	Foot	S513K	P1V-A160E0004
1600	21	18	716.0	1084.0	1600.0	31.7	G1/2	15/19	74.7	16000	3200	50	Flange	S614F	P1V-A160D0003	Foot	S614K	P1V-A160E0003
3200	800	565	51.0	77.0	42.0	65.0	G3/4	19/25	17.3	660	132	20	Flange	S122F	P1V-A320D0080	Foot	S122K	P1V-A320E0080
3200	520	365	79.5	119.0	115.0	65.0	G3/4	19/25	18.3	1750	350	25	Flange	S222F	P1V-A320D0052	Foot	S222K	P1V-A320E0052
3200	250	175	165.0	248.0	235.0	65.0	G3/4	19/25	20.3	3290	658	30	Flange	S322F	P1V-A320D0025	Foot	S322K	P1V-A320E0025
3200	110	80	362.0	544.0	500.0	65.0	G3/4	19/25	39.3	5130	1026	35	Flange	S412F	P1V-A320D0011	Foot	S412K	P1V-A320E0011
3200	55	40	710.0	1065.0	1000.0	65.0	G3/4	19/25	60.5	10000	2000	40	Flange	S513F	P1V-A320D0006	Foot	S513K	P1V-A320E0006
3200	30	20	1420.0	2130.0	1600.0	65.0	G3/4	19/25	76.0	16000	3200	50	Flange	S613F	P1V-A320D0003	Foot	S613K	P1V-A320E0003
5000	1050	625	72.0	108.0	80.0	96.7	G1	25/32	24.6	1370	274	25	Flange	S222F	P1V-A500D0105	Foot	S222K	P1V-A500E0105
5000	520	310	146.0	220.0	175.0	96.7	G1	25/32	27.0	2580	516	30	Flange	S322F	P1V-A500D0052	Foot	S322K	P1V-A500E0052
5000	250	150	302.0	450.0	385.0	96.7	G1	25/32	46.0	3880	776	35	Flange	S412F	P1V-A500D0025	Foot	S412K	P1V-A500E0025
5000	125	74	612.0	920.0	795.0	96.7	G1	25/32	67.2	8870	1770	40	Flange	S512F	P1V-A500D0013	Foot	S512K	P1V-A500E0013
5000	60	36	1230.0	1850.0	1600.0	96.7	G1	25/32	82.5	14500	2900	50	Flange	S613F	P1V-A500D0006	Foot	S613K	P1V-A500E0006
5000	30	18	2460.0	3700.0	4000.0	96.7	G1	25/32	164.0	35000	7000	70	Flange	S803F	P1V-A500D0003	Foot	S803K	P1V-A500E0003

•• Specify installation position in the order code as in the illustrations  
Maximum admissible speed (idling)  
Air consumption at the maximum air motor power

**Note!** specify installation position in the order code as in the illustration below.  
**Example: P1V-A160D0066B5**

**Note:** Oil-bath gearboxes mean that the installation position must be decided in advance. The installation position determines the volume of oil in the gearbox and location of oil filling and drain plugs.

**D: Installation positions, helical gear and flange mounting**

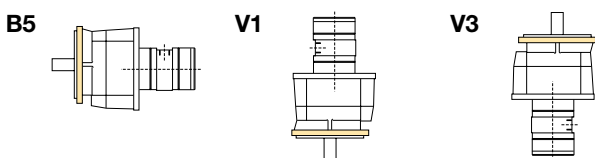

**E: Installation positions, helical gear and foot mounting**

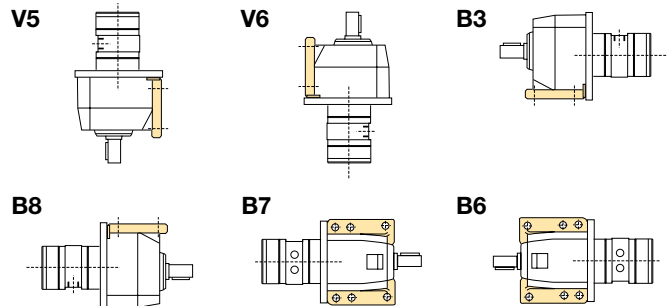

**P1V-A160D00\*\*\*\*, Spur gear box (D)**  
**Flange mounting**

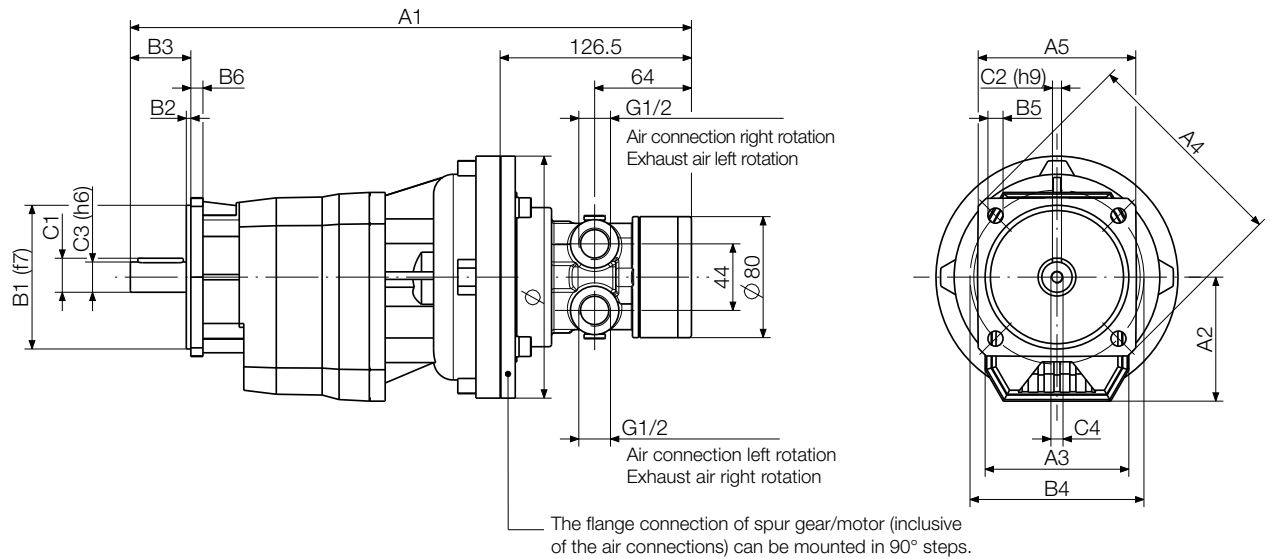

Order code	Dimensions (mm)														
	A1	A2	A3	A4	A5	B1	B2	B3	B4	B5	B6	C1	C2	C3	C4
P1V-A160D0066**	371,0	82,0	95,0	140,0	□ 105	95,0	3,0	40,0	115,0	9,5	8,0	22,5	6,0	20,0	M8 x 19
P1V-A160D0032**	400,0	94,0	110,0	160,0	□ 110	110,0	3,5	50,0	130,0	9,5	10,0	28,0	8,0	25,0	M8 x 19
P1V-A160D0014**	434,0	108,0	130,0	200,0	□ 150	130,0	3,5	60,0	165,0	11,5	12,0	33,0	8,0	30,0	M10 x 22
P1V-A160D0008**	463,0	128,0	155,0	250,0	-	180,0	4,0	70,0	215,0	14,0	13,0	38,0	10,0	35,0	M10 x 22
P1V-A160D0004**	489,0	152,0	185,0	300,0	-	230,0	4,0	80,0	265,0	14,0	16,0	43,0	12,0	40,0	M12 x 28
P1V-A160D0003**	616,0	178,5	210,0	350,0	-	250,0	5,0	100,0	300,0	18,0	18,0	53,5	14,0	50,0	M16 x 36

**P1V-A160E00\*\*\*\*, Spur gear box (E)**  
**Foot Bracket mounting**

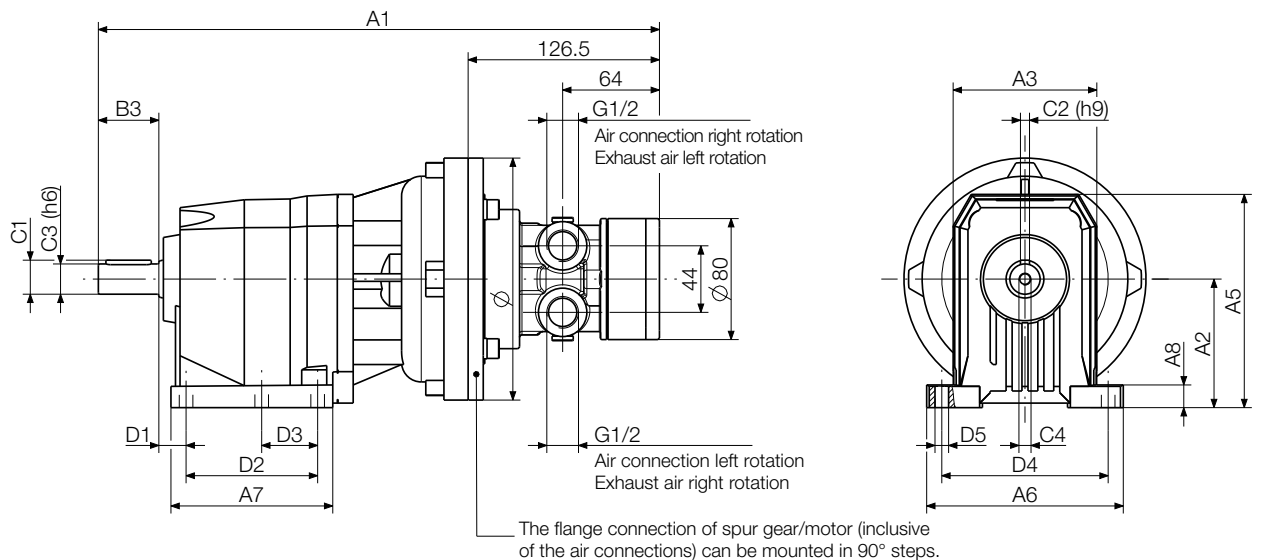

Order code	Dimensions (mm)																
	A1	A2	A3	A5	A6	A7	A8	B3	C1	C2	C3	C4	D1	D2	D3	D4	D5
P1V-A160E0066**	371,0	85,0	95,0	141,0	130,0	107,0	15,0	40,0	22,5	6,0	20,0	M8 x 19	18,0	87,0	37,0	110,0	9,0
P1V-A160E0032**	400,0	100,0	110,0	166,0	155,0	137,0	17,0	50,0	28,0	8,0	25,0	M8 x 19	18,0	107,5	47,5	130,0	11,0
P1V-A160E0014**	434,0	110,0	130,0	181,0	190,0	156,0	20,0	60,0	33,0	8,0	30,0	M10 x 22	18,0	130,0	60,0	160,0	11,0
P1V-A160E0008**	463,0	130,0	155,0	223,0	216,0	185,5	18,0	70,0	38,0	10,0	35,0	M10 x 22	19,5	149,5	-	180,0	14,0
P1V-A160E0004**	489,0	155,0	185,0	278,0	270,0	200,0	22,0	80,0	43,0	12,0	40,0	M12 x 28	25,0	156,0	-	225,0	18,0
P1V-A160E0003**	616,0	195,0	210,0	316,0	300,0	232,0	25,0	100,0	53,5	14,0	50,0	M16 x 36	25,0	180,0	-	250,0	18,0

**P1V-A320D00••••, Spur gear box (D)**  
**Flange mounting**

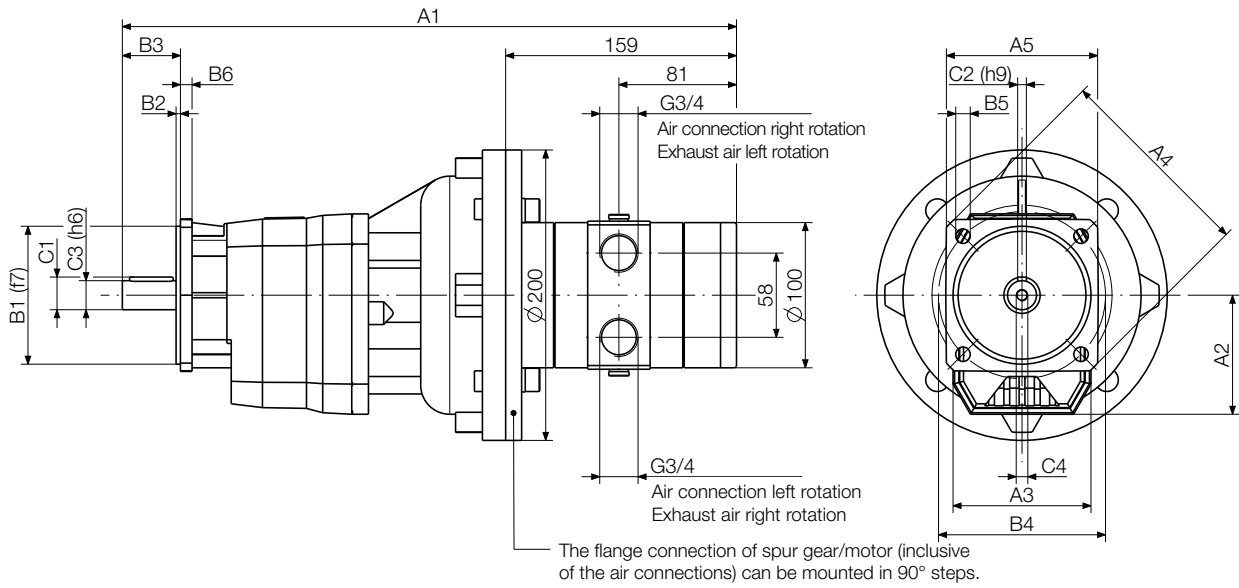

Order code	Dimensions (mm)															
	A1	A2	A3	A4	A5	B1	B2	B3	B4	B5	B6	C1	C2	C3	C4	
P1V-A320D0080••	423,0	82,0	95,0	140,0	□ 105	95,0	3,0	40,0	115,0	9,5	8,0	22,5	6,0	20,0	M8 x 19	
P1V-A320D0052••	451,0	94,0	110,0	160,0	□ 110	110,0	3,5	50,0	130,0	9,5	10,0	28,0	8,0	25,0	M8 x 19	
P1V-A320D0025••	486,0	108,0	130,0	200,0	□ 150	130,0	3,5	60,0	165,0	11,5	12,0	33,0	8,0	30,0	M10 x 22	
P1V-A320D0011••	515,0	128,0	155,0	250,0	-	180,0	4,0	70,0	215,0	14,0	13,0	38,0	10,0	35,0	M10 x 22	
P1V-A320D0006••	541,0	152,0	185,0	300,0	-	230,0	4,0	80,0	265,0	14,0	16,0	43,0	12,0	40,0	M12 x 28	
P1V-A320D0003••	594,0	178,5	210,0	350,0	-	250,0	5,0	100,0	300,0	18,0	18,0	53,5	14,0	50,0	M16 x 36	

**P1V-A320E00••••, Spur gear box (E)**  
**Foot Bracket mounting**

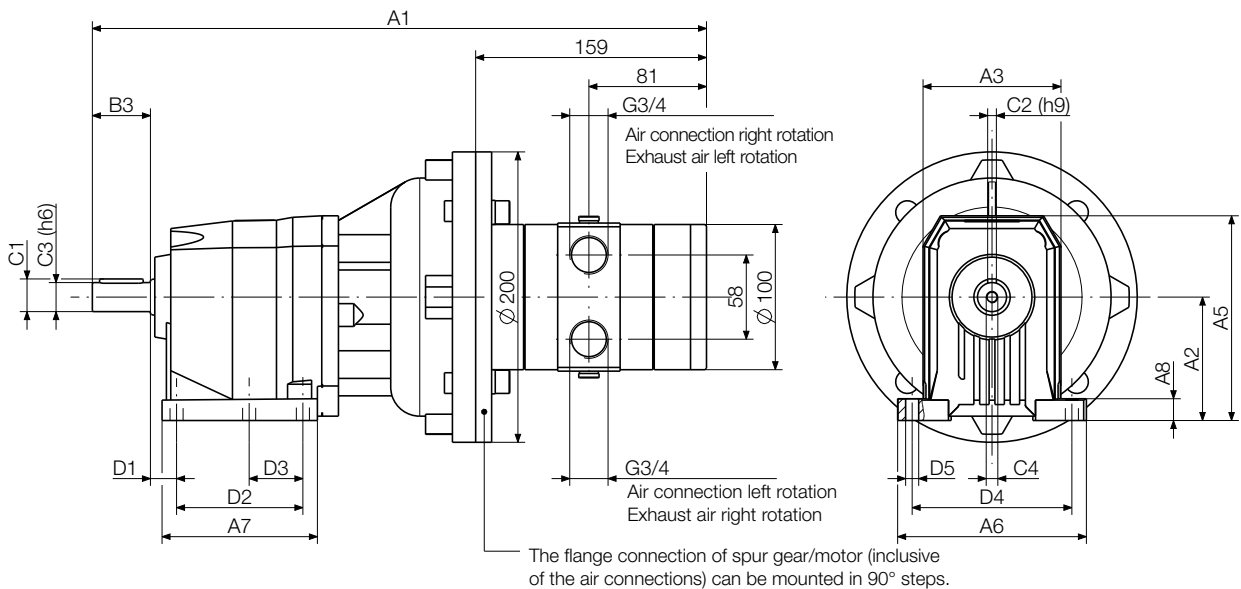

Order code	Dimensions (mm)																	
	A1	A2	A3	A5	A6	A7	A8	B3	C1	C2	C3	C4	D1	D2	D3	D4	D5	
P1V-A320E0080••	423,0	85,0	95,0	141,0	130,0	107,0	15,0	40,0	22,5	6,0	20,0	M8 x 19	18,0	87,0	37,0	110,0	9,0	
P1V-A320E0052••	451,0	100,0	110,0	166,0	155,0	137,0	17,0	50,0	28,0	8,0	25,0	M8 x 19	18,0	107,5	47,5	130,0	11,0	
P1V-A320E0025••	486,0	110,0	130,0	181,0	190,0	156,0	20,0	60,0	33,0	8,0	30,0	M10 x 22	18,0	130,0	60,0	160,0	11,0	
P1V-A320E0011••	515,0	130,0	155,0	223,0	216,0	185,5	18,0	70,0	38,0	10,0	35,0	M10 x 22	19,5	149,5	-	180,0	14,0	
P1V-A320E0006••	541,0	155,0	185,0	278,0	270,0	200,0	22,0	80,0	43,0	12,0	40,0	M12 x 28	25,0	156,0	-	225,0	18,0	
P1V-A320E0003••	594,0	195,0	210,0	316,0	300,0	232,0	25,0	100,0	53,5	14,0	50,0	M16 x 36	25,0	180,0	-	250,0	18,0	

**P1V-A500D00\*\*\*\*, Spur gear box (D)**  
**Flange mounting**

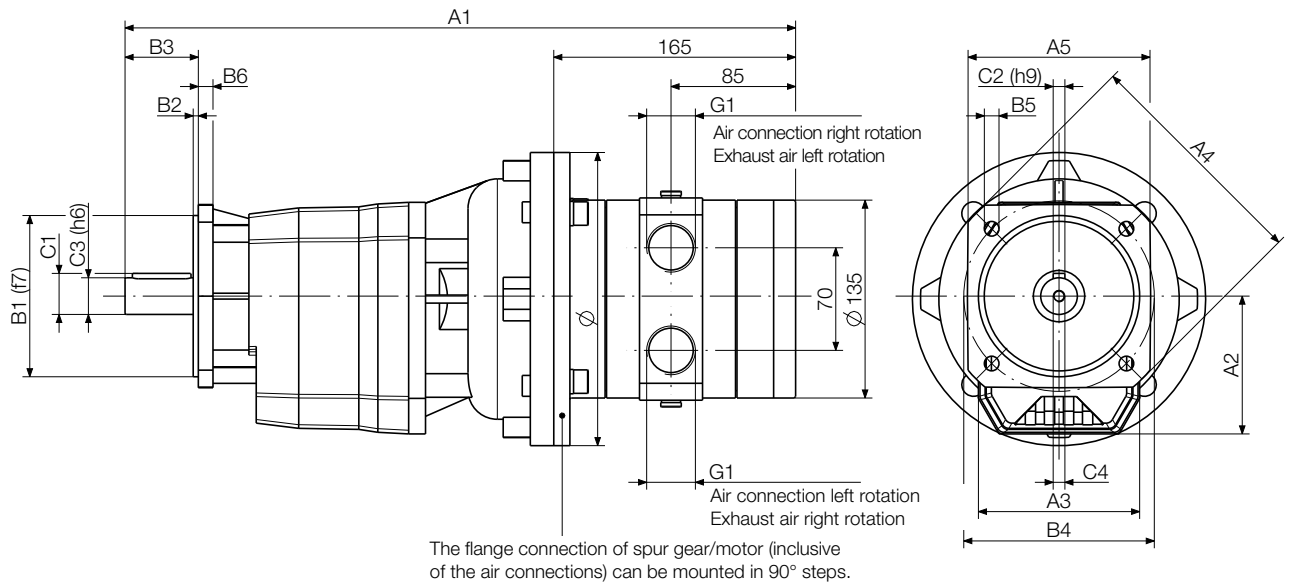

Order code	Dimensions (mm)															
	A1	A2	A3	A4	A5	B1	B2	B3	B4	B5	B6	C1	C2	C3	C4	
P1V-A500D0080**	458,0	94,0	110,0	160,0	□ 110	110,0	3,5	50,0	130,0	9,5	10,0	28,0	8,0	25,0	M8 x 19	
P1V-A500D0052**	492,0	108,0	130,0	200,0	□ 150	130,0	3,5	60,0	165,0	11,5	12,0	33,0	8,0	30,0	M10 x 22	
P1V-A500D0025**	521,0	128,0	155,0	250,0	-	180,0	4,0	70,0	215,0	14,0	13,0	38,0	10,0	35,0	M10 x 22	
P1V-A500D0011**	547,0	152,0	185,0	300,0	-	230,0	4,0	80,0	265,0	14,0	16,0	43,0	12,0	40,0	M12 x 28	
P1V-A500D0006**	600,0	178,5	210,0	350,0	-	250,0	5,0	100,0	300,0	18,0	18,0	53,5	14,0	50,0	M16 x 36	
P1V-A500D0003**	698,0	247,0	320,0	400,0	□ 350	300,0	5,0	140,0	350,0	18,0	20,0	85,0	22,0	80,0	M20 x 42	

**P1V-A500E00\*\*\*\*, Spur gear box (E)**  
**Foot Bracket mounting**

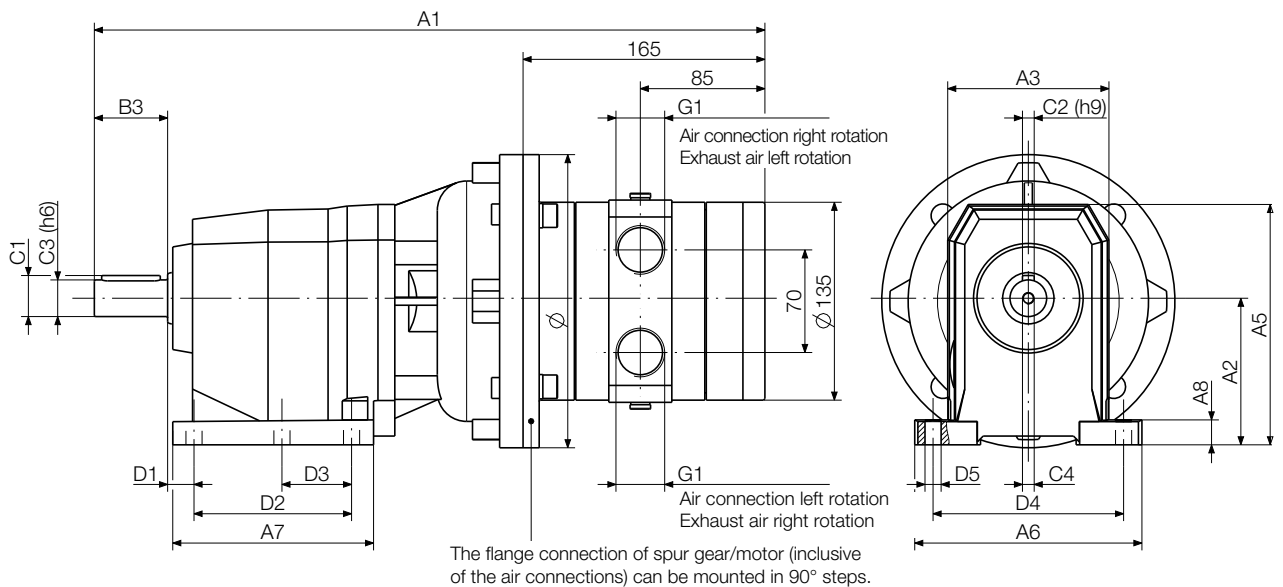

Order code	Dimensions (mm)																
	A1	A2	A3	A5	A6	A7	A8	B3	C1	C2	C3	C4	D1	D2	D3	D4	D5
P1V-A500E0080**	458,0	100,0	110,0	166,0	155,0	137,0	17,0	50,0	28,0	8,0	25,0	M8 x 19	18,0	107,5	47,5	130,0	11,0
P1V-A500E0052**	492,0	110,0	130,0	181,0	190,0	156,0	20,0	60,0	33,0	8,0	30,0	M10 x 22	18,0	130,0	60,0	160,0	11,0
P1V-A500E0025**	521,0	130,0	155,0	223,0	216,0	185,5	18,0	70,0	38,0	10,0	35,0	M10 x 22	19,5	149,5	-	180,0	14,0
P1V-A500E0011**	547,0	155,0	185,0	278,0	270,0	200,0	22,0	80,0	43,0	12,0	40,0	M12 x 28	25,0	156,0	-	225,0	18,0
P1V-A500E0006**	600,0	195,0	210,0	316,0	300,0	232,0	25,0	100,0	53,5	14,0	50,0	M16 x 36	25,0	180,0	-	250,0	18,0
P1V-A500E0003**	698,0	250,0	320,0	420,0	440,0	277,0	35,0	140,0	85,0	22,0	80,0	M20 x 42	33,0	210,0	-	370,0	26,0

**Note!** All technical data are based on a working pressure of 6 bar and with oil.  
 Speed tolerance accuracy is  $\pm 10\%$ .

**For ATEX conformity, please contact Technical Sales**

**Note!** Inlet and exhaust air flows are critical for reaching the best performances.



**F, G, H: Reversible motor with worm gear box, flange left (F) or right (G), foot bracket or universal (H) mountings**

Max power	Free speed	Nominal speed	Nominal torque	Min starting torque	Max gear box permanent torque	Air consumption	Conn.	Min pipe ID inlet/outlet	Weight	Max permissible shaft loading	Mounting	Gear box type	Order code	Flange	Gear box type	Order code	Flange	Gear box type	Order code	
Watt	rpm	rpm	Nm	Nm	Nm	l/s	BSP	mm	kg	F radial (N)	F axial (N)									
1600	430	320	40.0	42.0	49.0	31.7	G1/2	15/19	8.2			Bracket	W49KA	P1V-A160H0043**	On left	W49F	P1V-A160F0043**	On right	W49F	P1V-A160G0043**
1600	200	150	79.0	67.0	125.0	31.7	G1/2	15/19	11.5			Universal	W63U	P1V-A160H0020**	Option	-	-	Option	-	-
1600	95	70	159.0	121.0	250.0	31.7	G1/2	15/19	18.8			Universal	W86U	P1V-A160H0010**	Option	-	-	Option	-	-
1600	75	55	191.0	137.0	225.0	31.7	G1/2	15/19	18.8			Universal	W86U	P1V-A160H0008**	Option	-	-	Option	-	-
3200	500	350	76.0	86.0	125.0	65.0	G3/4	19/25	16.8			Universal	W63U	P1V-A320H0050**	Option	-	-	Option	-	-
3200	220	150	170.0	174.0	285.0	65.0	G3/4	19/25	24.1			Universal	W86U	P1V-A320H0022**	Option	-	-	Option	-	-
3200	125	85	280.0	240.0	295.0	65.0	G3/4	19/25	24.1			Universal	W86U	P1V-A320H0013**	Option	-	-	Option	-	-
3200	62	44	508.0	365.0	660.0	65.0	G3/4	19/25	63.0			Bracket	W130K	P1V-A320H0006**	On left	W130F	P1V-A320F0006**	On right	W130F	P1V-A320G0006**
5000	500	300	143.0	160.0	205.0	96.7	G1	25/32	26.6			Universal	W75U	P1V-A500H0050**	Option	-	-	Option	-	-
5000	220	130	315.0	325.0	480.0	96.7	G1	25/32	45.0			Universal	W110U	P1V-A500H0022**	Option	-	-	Option	-	-
5000	125	75	509.0	439.0	595.0	96.7	G1	25/32	48.0			Universal	W110U	P1V-A500H0013**	Option	-	-	Option	-	-
5000	55	37	980.0	930.0	1250.0	96.7	G1	25/32	79.0			Bracket	WR130A	P1V-A500H0006**	On left	WR130F	P1V-A500F0006**	On right	WR130F	P1V-A500G0006**

\*\* Specify installation position in the order code as in the illustrations  
 Maximum admissible speed (idling)  
 Air consumption at the maximum air motor power

**Note!**  
 • specify installation position in the order code as in the illustration below.  
**Example: P1V-A160H0043B3**

**F, G, H: Installation positions, worm gear, foot mounting**

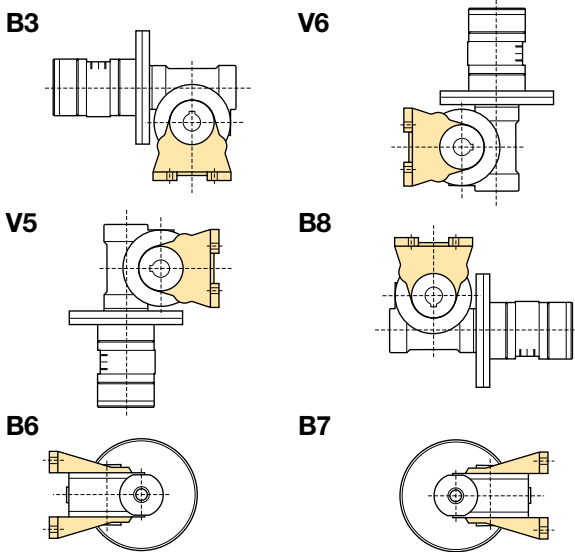

**Note:** Oil-bath gearboxes mean that the installation position must be decided in advance. The installation position determines the volume of oil in the gearbox and location of oil filling and drain plugs.

**Self-locking**

Dynamic self-locking means that the force acting on the output shaft of the gear can not turn the gear further when the air motor is stopped. Dynamic self-locking is only possible when the gear ratio is high, and at low speeds. None of our worm drive gears are completely self-locking in dynamic conditions.

Static self-locking means that the force acting on the output shaft of the gear can not begin to turn the shaft.

When loads with considerable momentum are driven, it is necessary to have a braking time sufficient to stop the gearbox from being overloaded. It is extremely important that the maximum permitted torque is not exceeded.

*Tip:* Braking of the air motor can be arranged by either slowly restricting the air supply to the motor until it is completely shut off, or by slowly reducing the supply pressure to zero.

**Types of Self-locking**

1. Static, not self-locking
2. Static, self-locking - quicker return under vibration - not dynamically self-locking
3. Static, self-locking - return only possible under vibration - good dynamic self-locking



**Important!**

Since it is practically impossible to guarantee total self-locking, an external brake must be used to guarantee that vibration can not cause an output shaft to move.

**P1V-A160G0043••, worm gear box (G)**  
**Flange on right side**

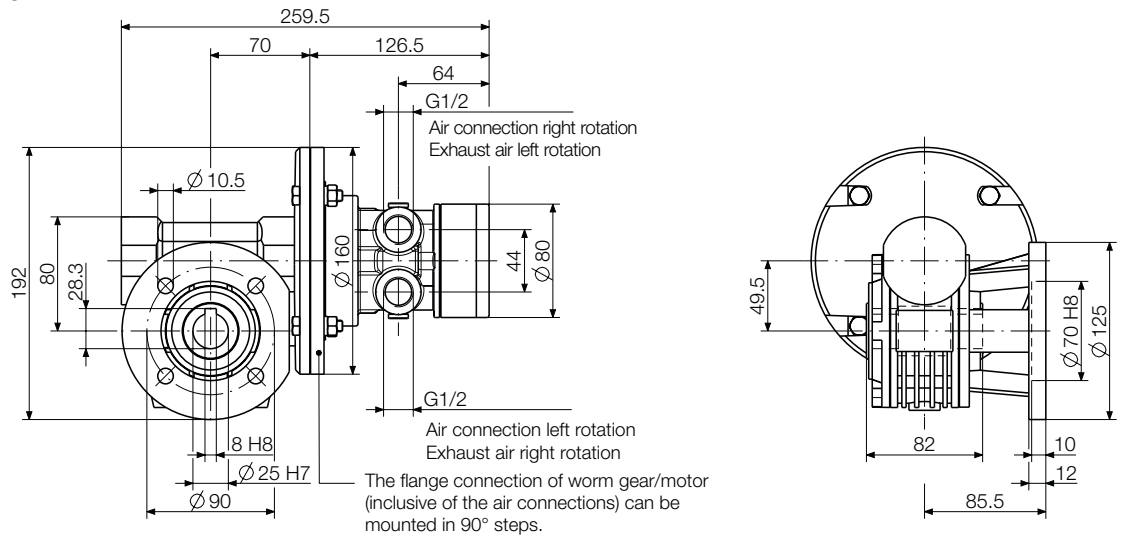

**P1V-A160F0043••, worm gear box (F)**  
**Flange on left side**

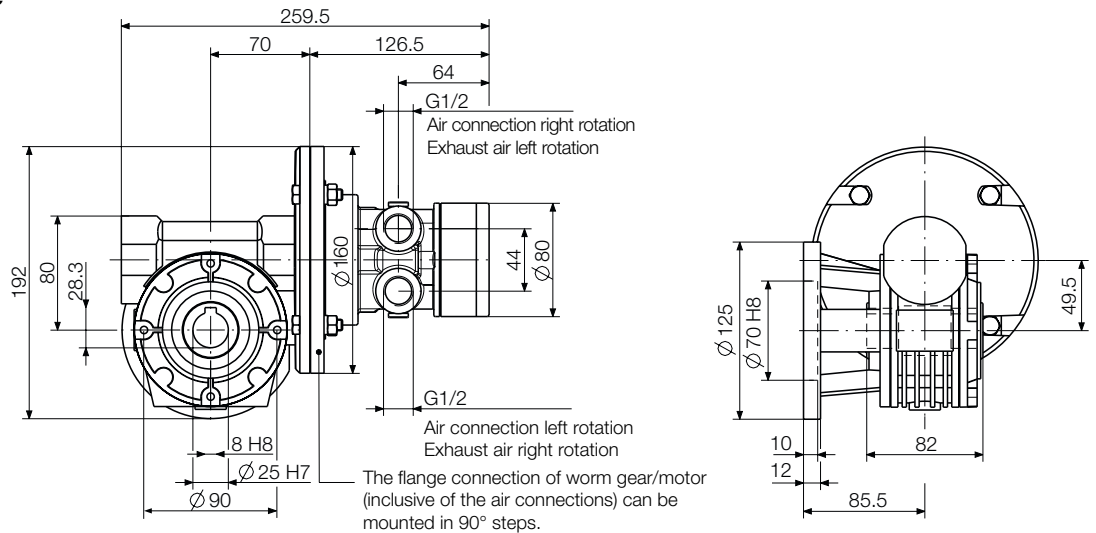

**P1V-A160H0043••, worm gear box (H)**  
**Foot bracket**

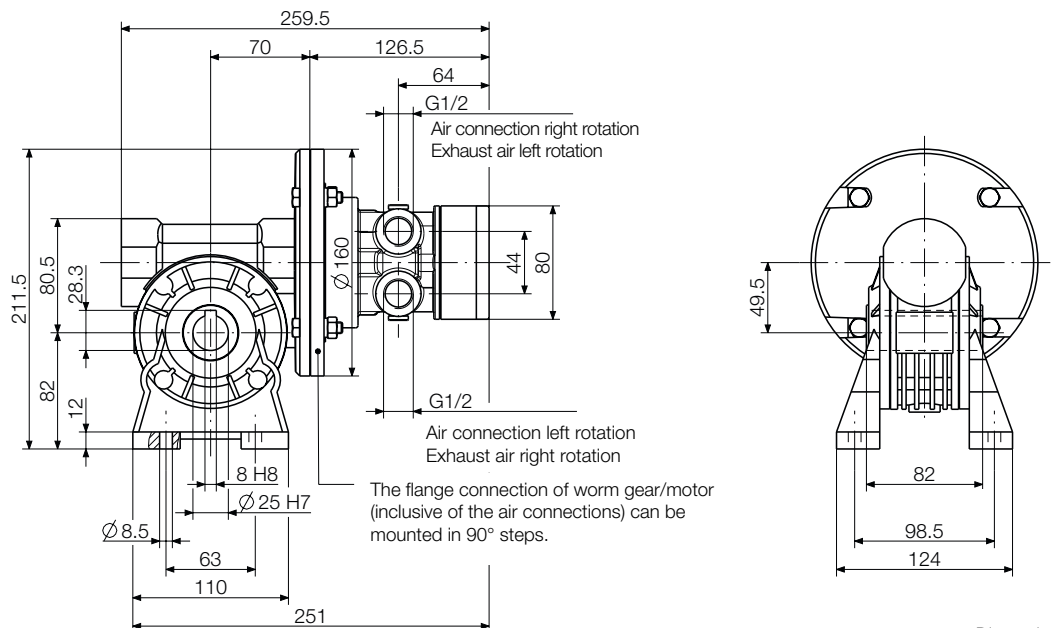

Dimensions in mm

**P1V-A160H00••••, worm gear box (H) Universal mounting  
Without flanges**

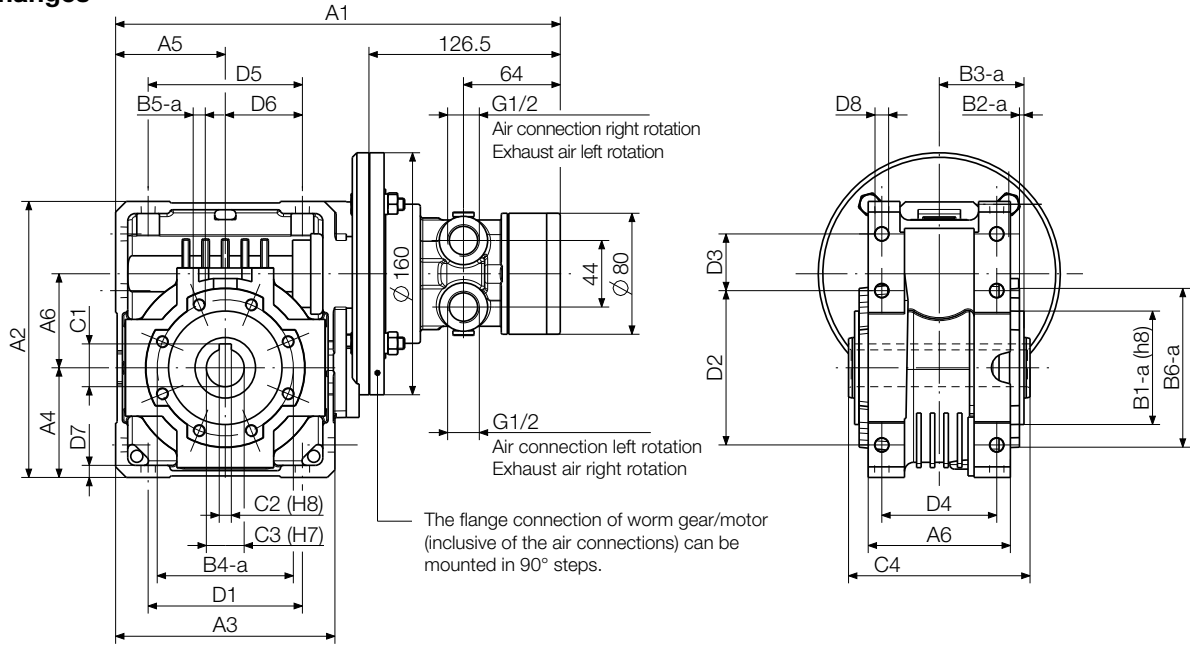

**With wide flange  
Adaption possible on both sides**

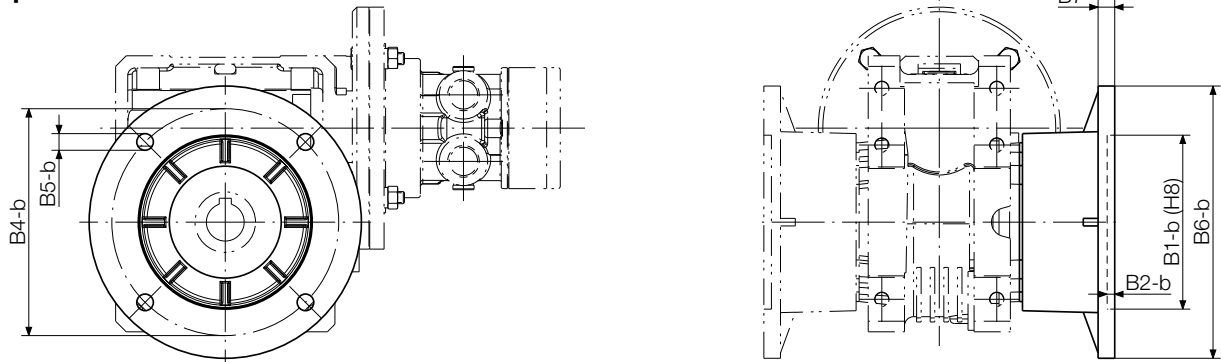

**With close flange  
Adaption possible on both sides**

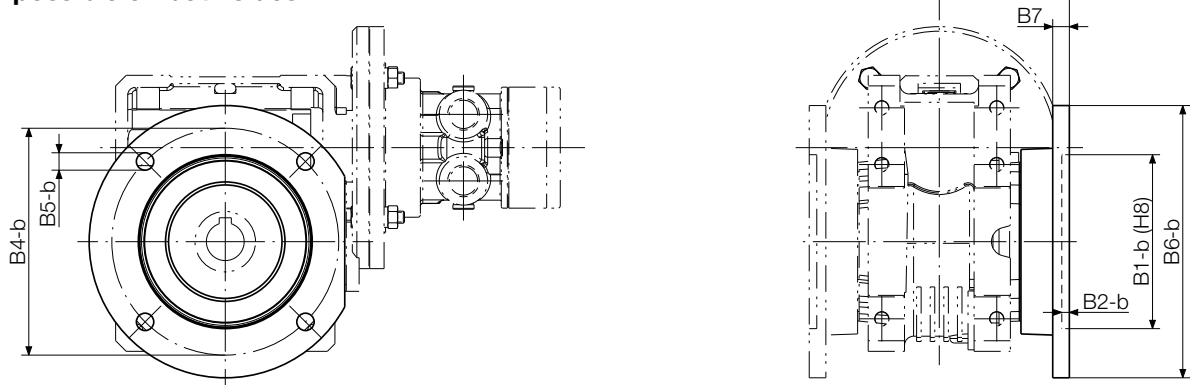

Order code	Dimensions (mm)															
	A1	A2	A3	A4	A5	A6	B1-a	B1-b	B2-a	B2-b	B3-a	B3-b	B3-c	B4-a	B4-b	B5-a
P1V-A160H0020••	294.0	182.5	145.0	72.5	72.5	94.0	75.0	115.0	3.0	5.0	56.0	116.0	-	90.0	150.0	M8x14
P1V-A160H0010••	355.0	245.5	200.0	100.0	100.0	125.0	110.0	152.0	3.5	6.0	68.0	151.0	-	130.0	176.0	M10x18
P1V-A160H0008••	355.0	245.5	200.0	100.0	100.0	125.0	110.0	152.0	3.5	6.0	68.0	-	-	130.0	176.0	M10x18
	B5-b	B6-a	B6-b	B7	C1	C2	C3	C4	D1	D2	D3	D4	D5	D6	D7	D8
P1V-A160H0020••	11.0	105.0	180.0	11.0	28.3	8.0	25.0	120.0	102.0	102.0	37.5	76.0	102.0	51.0	8.0	9.0
P1V-A160H0010••	12.5	150.0	210.0	15.0	38.3	10.0	35.0	140.0	144.0	144.0	45.5	101.0	144.0	72.0	11.0	11.5
P1V-A160H0008••	12.5	150.0	210.0	15.0	38.3	10.0	35.0	140.0	144.0	144.0	45.5	101.0	144.0	72.0	11.0	11.5



**P1V-A320G0006••, worm gear box (G)**  
**Flange on right side**

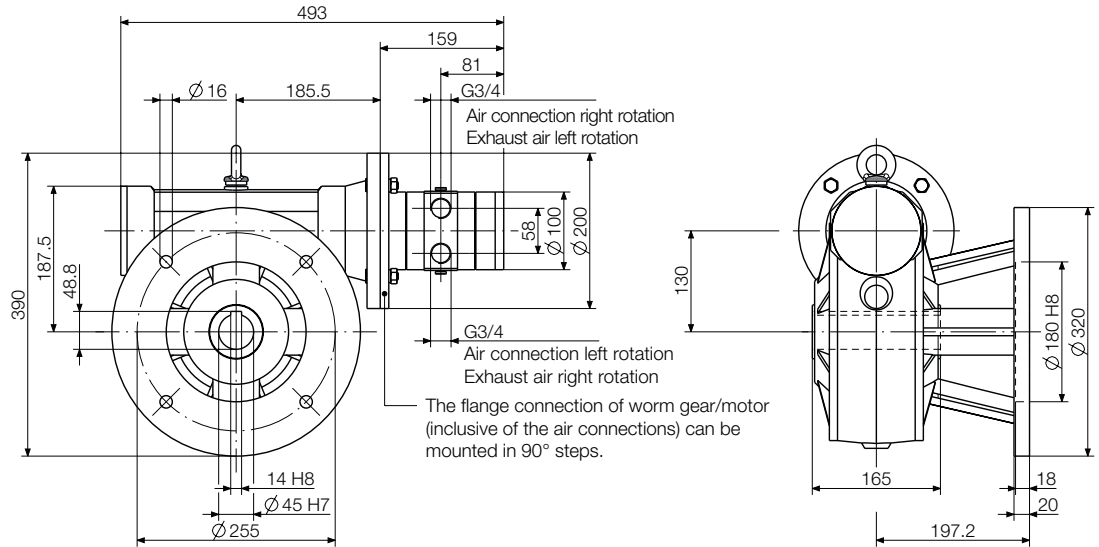

**P1V-A320F0006••, worm gear box (F)**  
**Flange on left side**

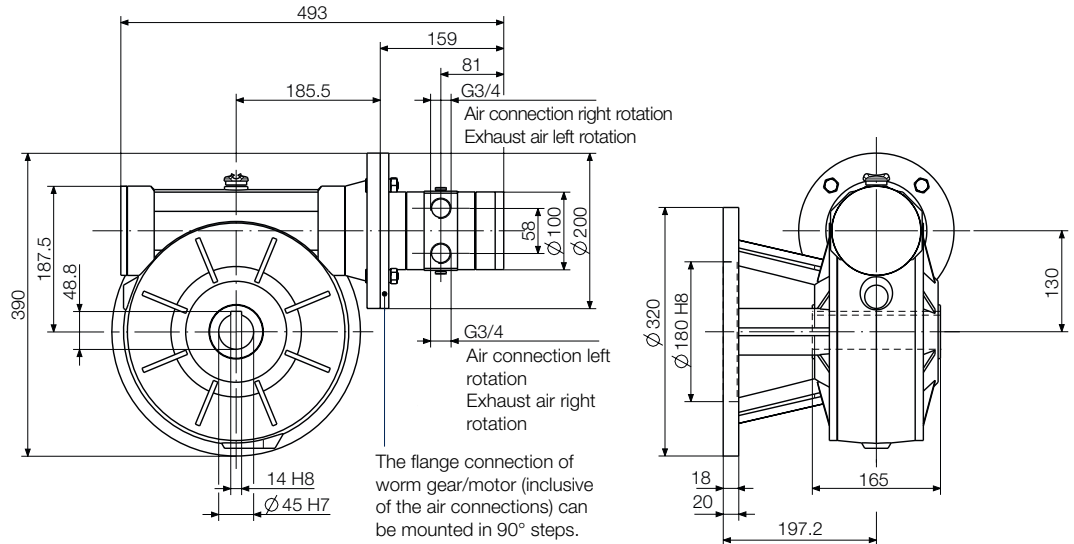

**P1V-A320H0006••, worm gear box (H)**  
**Foot bracket**

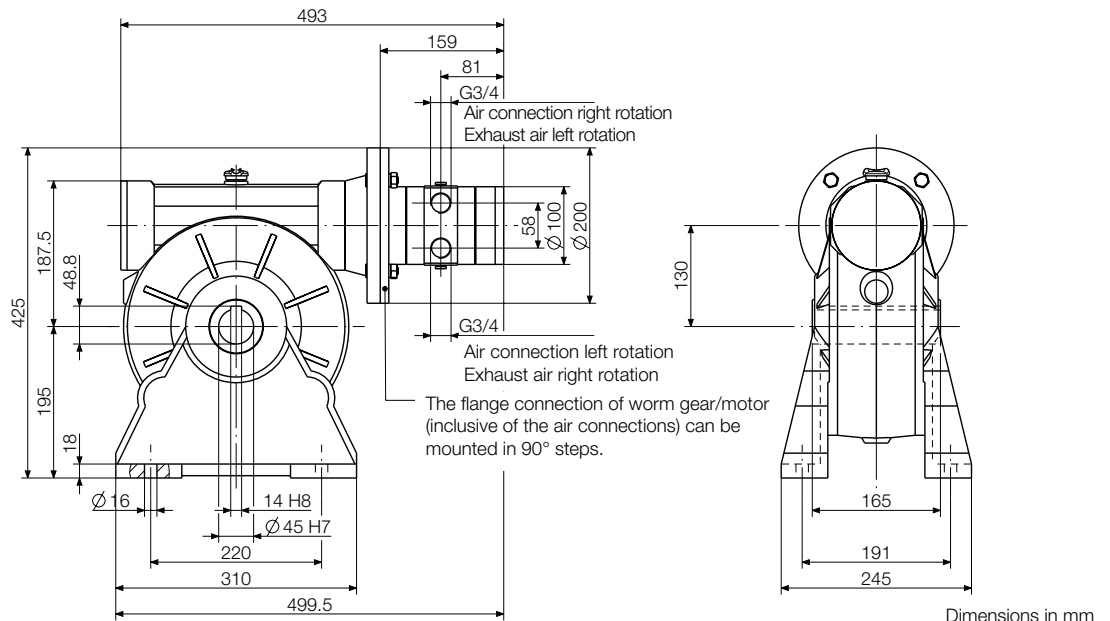

Dimensions in mm

**P1V-A320H00••••, worm gear box (H) Universal mounting  
Without flanges**

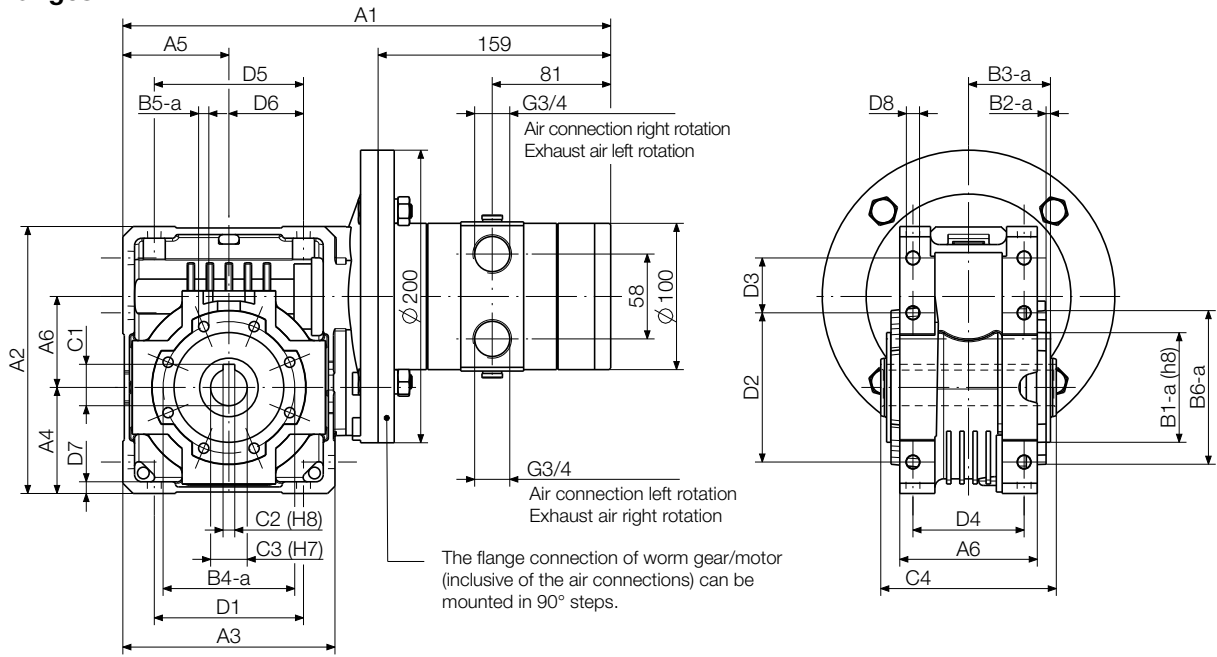

**With wide flange  
Adaption possible on both sides**

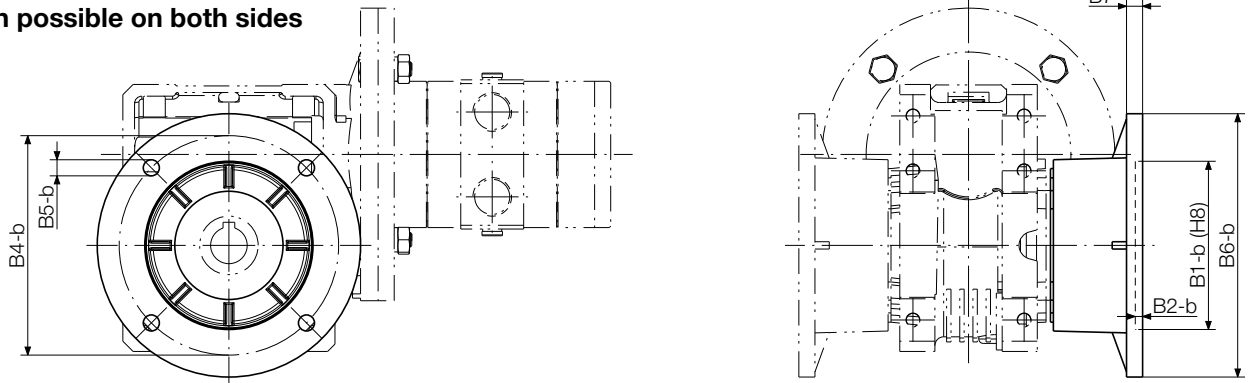

**With close flange  
Adaption possible on both sides**

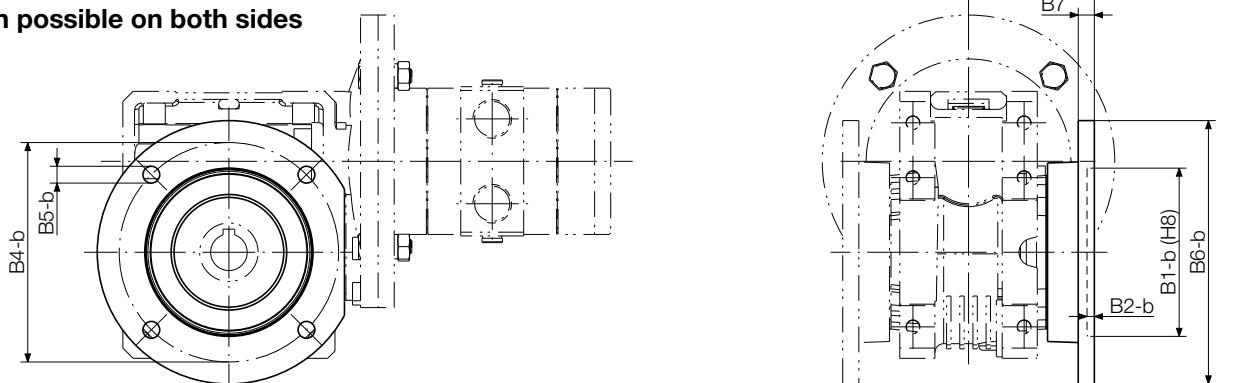

Order code	Dimensions (mm)															
	A1	A2	A3	A4	A5	A6	B1-a	B1-b	B2-a	B2-b	B3-a	B3-b	B3-c	B4-a	B4-b	B5-a
P1V-A320H0050••	334.0	182.5	145.0	72.5	72.5	94.0	75.0	115.0	3.0	5.0	56.0	116.0	86.0	90.0	150.0	M8x14
P1V-A320H0022••	387.0	245.5	200.0	100.0	100.0	125.0	110.0	152.0	3.5	6.0	68.0	151.0	110.5	130.0	176.0	M10x18
P1V-A320H0013••	387.0	245.5	200.0	100.0	100.0	125.0	110.0	152.0	3.5	6.0	68.0	-	110.5	130.0	176.0	M10x18
	B5-b	B6-a	B6-b	B7	C1	C2	C3	C4	D1	D2	D3	D4	D5	D6	D7	D8
P1V-A320H0050••	11.0	105.0	180.0	11.0	28.3	8.0	25.0	120.0	102.0	102.0	37.5	76.0	102.0	51.0	8.0	9.0
P1V-A320H0022••	12.5	150.0	210.0	15.0	38.3	10.0	35.0	140.0	144.0	144.0	45.5	101.0	144.0	72.0	11.0	11.5
P1V-A320H0013••	12.5	150.0	210.0	15.0	38.3	10.0	35.0	140.0	144.0	144.0	45.5	101.0	144.0	72.0	11.0	11.5

**P1V-A500G0006••, worm gear box (G)**  
**Flange on right side**

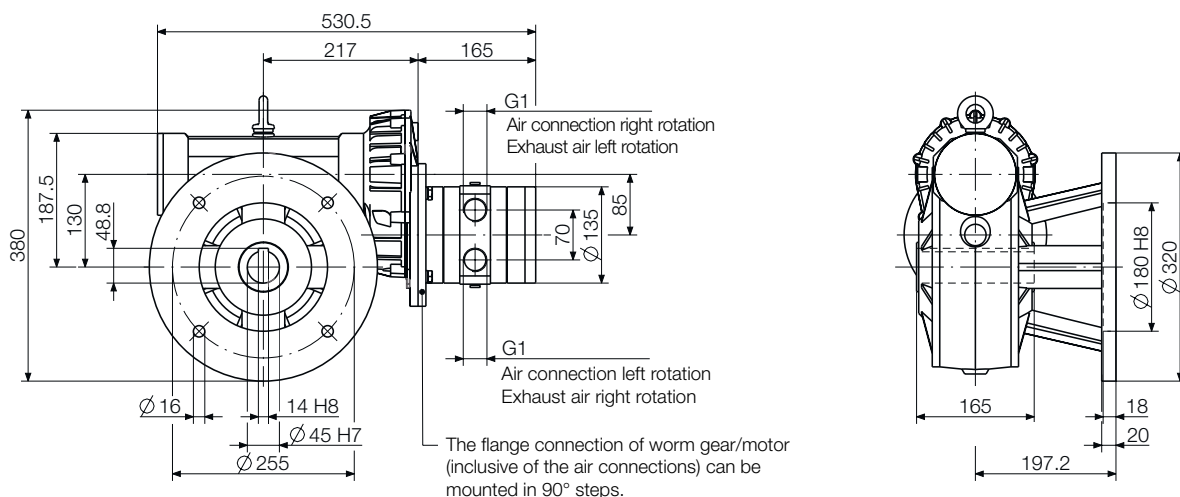

**P1V-A500F0006••, worm gear box (F)**  
**Flange on left side**

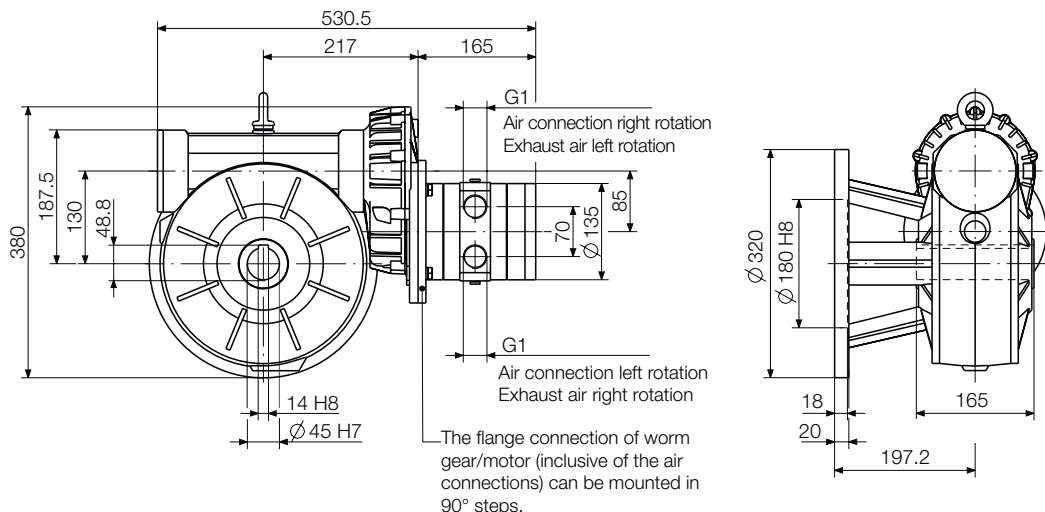

**P1V-A500H0006••, worm gear box (H)**  
**Foot bracket**

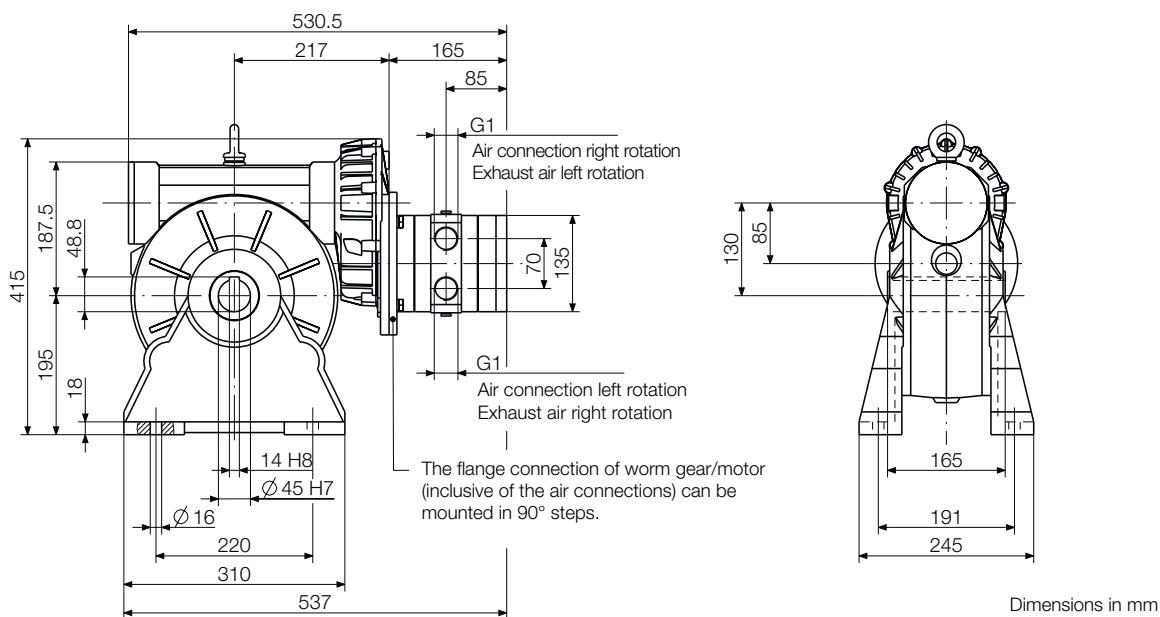

Dimensions in mm

**P1V-A500H00••••, worm gear box (H) Universal mounting  
Without flanges**

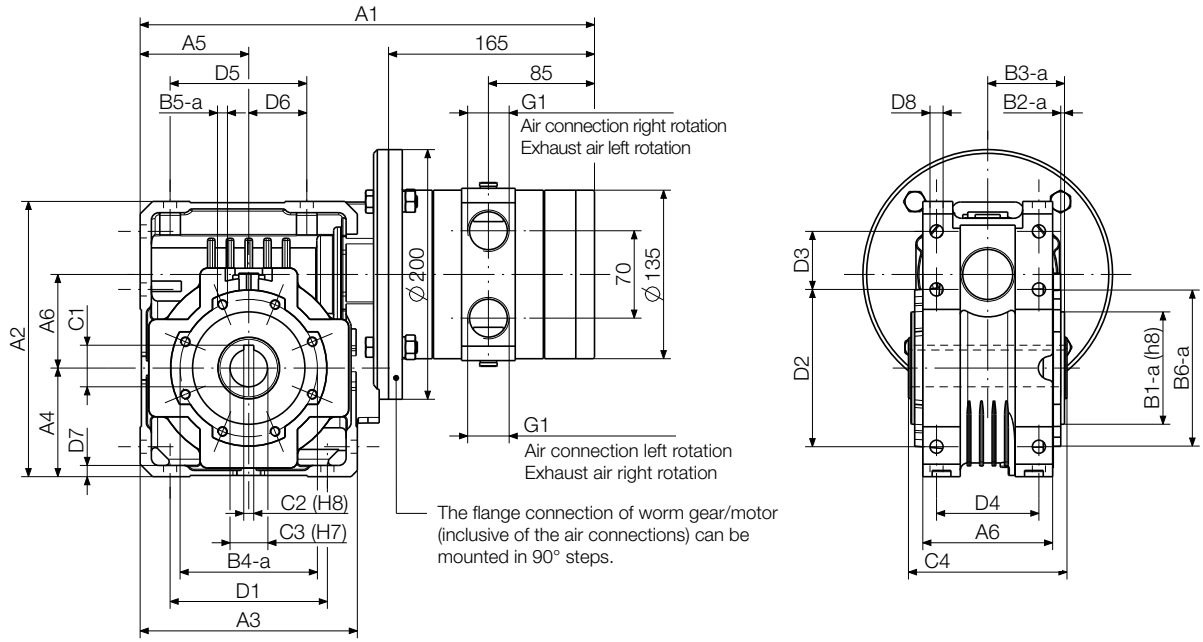

**With wide flange  
Adaption possible on both sides**

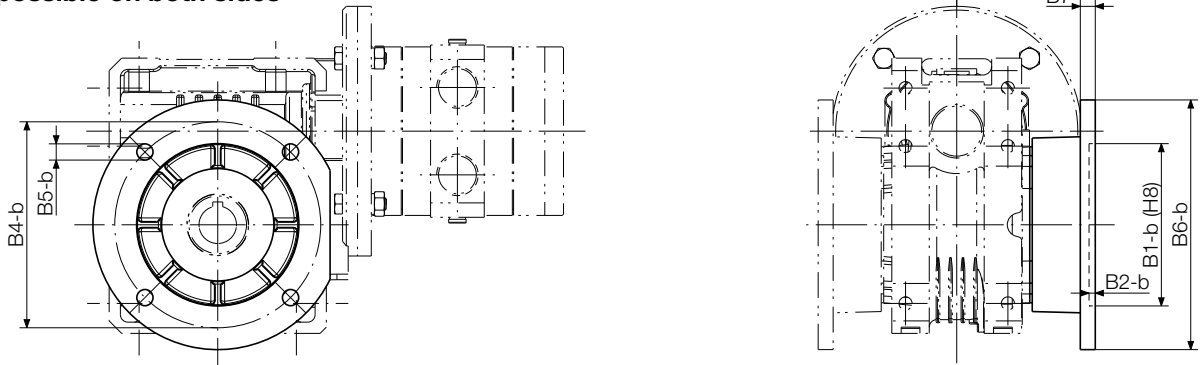

**With close flange  
Adaption possible on both sides**

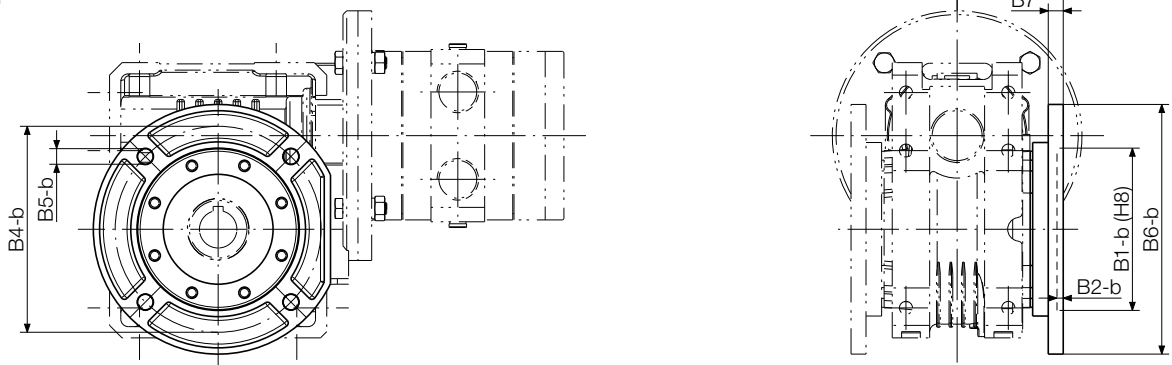

Order code	Dimensions (mm)															
	A1	A2	A3	A4	A5	A6	B1-a	B1-b	B2-a	B2-b	B3-a	B3-b	B3-c	B4-a	B4-b	B5-a
P1V-A500H0050••	364.0	220.5	174.0	87.0	87.0	75.0	90.0	130.0	3.0	5.0	61.5	110.0	85.0	110.0	165.0	M8 x 14
P1V-A500H0022••	433.0	308.0	250.0	125.0	125.0	110.1	130.0	170.0	3.5	12.0	76.5	179.5	131.5	165.0	230.0	M12 x 19
P1V-A500H0013••	433.0	308.0	250.0	125.0	125.0	110.1	130.0	170.0	3.5	12.0	76.5	179.5	131.5	165.0	230.0	M12 x 19
	B5-b	B6-a	B6-b	B7	C1	C2	C3	C4	D1	D2	D3	D4	D5	D6	D7	D8
P1V-A500H0050••	12.5	125.0	200.0	12.0	33.3	8.0	30.0	127.0	126.0	126.0	46.5	82.0	109.5	46.5	9.0	10.5
P1V-A500H0022••	13.0	200.0	280.0	20.0	45.3	12.0	42.0	155.0	184.0	184.0	58.0	115.0	174.0	82.0	14.0	14.0
P1V-A500H0013••	13.0	200.0	280.0	20.0	45.3	12.0	42.0	155.0	184.0	184.0	58.0	115.0	174.0	82.0	14.0	14.0

Shafts with keys and additional flanges for motors with worm gear boxes

Single-ended shafts with keys for motors with worm gear boxes (F, G, H types)

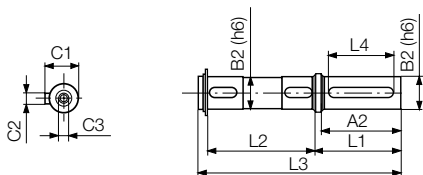

Order code	for hollow shaft mm	max. radial force N	max. axial force N	Weight kg	Dimensions (mm)								
					A2	B2	C1	C2	C3	L1	L2	L3	L4
9121510242	Ø25 x 82	3450	690	0.6	60.0	25.0	28.0	8.0	M8	65.0	82.0	154.0	50.0
9121510243	Ø25 x 120	5000	1000	0.75	60.0	25.0	28.0	8.0	M8	65.0	120.0	192.0	50.0
P1V-A/107573	Ø30 x 127	6200	1240	0.85	60.0	30.0	33.0	8.0	M10	65.0	127.0	199.0	50.0
9121510244	Ø35 x 140	7000	1400	1.6	60.0	35.0	38.0	10.0	M10	65.0	140.0	214.0	50.0
9121510245	Ø42 x 155	8000	1600	2.8	75.0	42.0	45.0	12.0	M12	80.0	155.0	244.0	60.0
9121510246	Ø45 x 165	13800	2760	3.2	80.0	45.0	48.5	14.0	M12	85.0	165.0	261.0	70.0

C2: UNI 6604, DIN 6885

Double-ended shafts with keys for motors with worm gear boxes (F, G, H types)

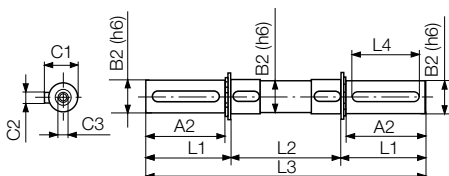

Order code	for hollow shaft mm	max. radial force N	max. axial force N	Weight kg	Dimensions (mm)								
					A2	B2	C1	C2	C3	L1	L2	L3	L4
9121510247	Ø25 x 82	3450	690	0.78	60.0	25.0	28.0	8.0	M8	63.2	82.0	208.4	50.0
9121510248	Ø25 x 120	5000	1000	0.98	60.0	25.0	28.0	8.0	M8	63.2	120.0	246.4	50.0
P1V-A/813122	Ø30 x 127	6200	1240	1.11	60.0	30.0	33.0	8.0	M10	64.0	127.0	255.0	50.0
9121510249	Ø35 x 140	7000	1400	2.08	60.0	35.0	38.0	10.0	M10	64.0	140.0	268.0	50.0
9121510250	Ø42 x 155	8000	1600	3.64	75.0	42.0	45.0	12.0	M12	79.2	155.0	313.4	60.0
9121510251	Ø45 x 165	13800	2760	4.16	80.0	45.0	48.5	14.0	M12	84.7	165.0	334.4	70.0

C2: UNI 6604, DIN 6885

Material specification

Shaft	High grade steel
Key	Hardened steel

Wide Flanges for motors with worm gear boxes (F, G, H types)



Gear box type & size	Order code Wide flange	Dimensions (mm)									
		B6-b	B1-b(H8)	B2-b	B3-b	B4-a	B4-b	B5-a	B5-b	B6-a	B7
W63U	P1V-A/830929	180.0	115.0	5.0	116.0	90	150.0	M8x14	11.0	105.0	11.0
W75U	P1V-A/834335	210.0	152.0	6.0	151.0	130	176.0	M10x18	12.5	150.0	15.0
W86U	P1V-A/830931	210.0	152.0	6.0	-	130	176.0	M10x18	12.5	150.0	15.0
W110U	P1V-A/830934	280.0	170.0	12.0	179.5	165.0	230.0	M12x19	13.0	200.0	20.0

Kit contains the flange and the screws to fix on the gear box

Close Flanges for motors with worm gear boxes (F, G, H types)



Gear box type & size	Order code Wide flange	Dimensions (mm)									
		B6-b	B1-b(H8)	B2-b	B3-b	B4-a	B4-b	B5-a	B5-b	B6-a	B7
W63U	P1V-A/830930	180.0	115.0	5.0	116.0	90	150.0	M8x14	11.0	105.0	11.0
W75U	P1V-A/106042	210.0	152.0	6.0	151.0	130	176.0	M10x18	12.5	150.0	15.0
W86U	P1V-A/830932	210.0	152.0	6.0	-	130	176.0	M10x18	12.5	150.0	15.0
W110U	P1V-A/830935	280.0	170.0	12.0	179.5	165.0	230.0	M12x19	13.0	200.0	20.0

Kit contains the flange and the screws to fix on the gear box

Material specification

Flange	Aluminium
Screws	Zinc coated steel

## Lubrication and service life

Oil and oil mist are things which one tries to avoid to get the best possible working environment. In addition, purchasing, installation and maintenance of oil mist equipment costs money and, above all, time to achieve optimum lubrication effect.

The P1V-A motor is equipped with vanes for intermittent operation as standard for most common applications.

## Service interval



The first service is due after approximately 500 hours of operation. After the first service, the service interval is determined by the degree of vane wear.

The following normal service intervals should be applied to in order to guarantee problem-free operation in air motors working continuously at load speeds.

### Intermittent lubrication operation

Duty cycle	70%
Max. duration of intermittent use	15 minutes
Oil volume	1 drop oil/Nm <sup>3</sup>
Filtering 40 µm	app. 750 hours operation
Filtering 5 µm	app. 1,000 hours operation

### Continuous lubrication operation

Oil volume	1 drop oil/Nm <sup>3</sup>
Filtering 40 µm	app. 1,000 hours operation
Filtering 5 µm	app. 2,000 hours operation

### Continuous lubrication operation

Oil volume	Oil free
Filtering 40 µm	app. 750 hours operation
Filtering 5 µm	app. 1,000 hours operation

### Standard vanes (0, D):

For intermittent lubrication-free operation.

They can operate 70% of the time for up to 15 minutes without lubrication.

With lubrication, these motors can operation 100% of the time.

### "Black" vanes (C, E):

For continuous lubrication-free operation.

(To obtain the longest possible service life, we recommend no oil in the air.)

## Service kits

The following kits are available for the basic motors, consisting of vanes, O-rings and springs:

Motor type	Motor power Watt	Order code	
		Vanes for intermittent lubrication operation, options "O & D"	Vanes for continuous lubrication operation, options "C & E"
P1V-A160A0900	1600	P1V-6/4450331B	P1V-6/4450332B
P1V-A160D0300	1600	P1V-6/4450331D	P1V-6/4450332D
P1V-A160B0140	1600	P1V-6/4450331E	P1V-6/4450332E
P1V-A160B●●●●	1600	P1V-6/4450331B	P1V-6/4450332B
P1V-A160H●●●●●	1600	P1V-6/4450331B	P1V-6/4450332B
P1V-A160F●●●●●	1600	P1V-6/4450331B	P1V-6/4450332B
P1V-A160G●●●●●	1600	P1V-6/4450331B	P1V-6/4450332B
P1V-A160D●●●●●	1600	P1V-6/4450331B	P1V-6/4450332B
P1V-A160E●●●●●	1600	P1V-6/4450331B	P1V-6/4450332B
P1V-A320A0700	3200	P1V-6/4450341B	P1V-6/4450342B
P1V-A320D0300	3200	P1V-6/4450341D	P1V-6/4450342D
P1V-A320B0140	3200	P1V-6/4450341E	P1V-6/4450342E
P1V-A320B0060	3200	P1V-6/4450341B	P1V-6/4450342B
P1V-A320H●●●●●	3200	P1V-6/4450341B	P1V-6/4450342B
P1V-A320F●●●●●	3200	P1V-6/4450341B	P1V-6/4450342B
P1V-A320G●●●●●	3200	P1V-6/4450341B	P1V-6/4450342B
P1V-A320D●●●●●	3200	P1V-6/4450341B	P1V-6/4450342B
P1V-A320E●●●●●	3200	P1V-6/4450341B	P1V-6/4450342B
P1V-A500A0600	5000	P1V-6/4450351B	P1V-6/4450352B
P1V-A500D0300	5000	P1V-6/4450351D	P1V-6/4450352D
P1V-A500B0145	5000	P1V-6/4450351E	P1V-6/4450352B
P1V-A500H●●●●●	5000	P1V-6/4450351B	P1V-6/4450352B
P1V-A500F●●●●●	5000	P1V-6/4450351B	P1V-6/4450352B
P1V-A500G●●●●●	5000	P1V-6/4450351B	P1V-6/4450352B
P1V-A500D●●●●●	5000	P1V-6/4450351B	P1V-6/4450352B
P1V-A500E●●●●●	5000	P1V-6/4450351B	P1V-6/4450352B
P1V-A600A0700	6000	P1V-6/4450351B	P1V-6/4450352B
P1V-A600D0350	6000	P1V-6/4450351D	P1V-6/4450352D
P1V-A600B0160	6000	P1V-6/4450351E	P1V-6/4450352E
P1V-A900A0600	9000	P1V-6/440246C	-
P1V-AJ00A0600	18000	P1V-6/440246B	-

●●●●● Rest of the air motor order code

For more information about our maintenance services, please contact your local parker sales office.

**Order key**

<b>P 1 V - A</b>	<b>1 6 0</b>	<b>E 0</b>	<b>0 6 6</b>	<b>B 6</b>
<b>Air Motor Family</b>	<b>Size (power)</b>		<b>Free/max speed</b>	<b>Installation position</b>
P1V-A Power Line Air Motor				

Function		Optional function *			
		0	C	D	E
		Standard vanes	"Black" vanes	0 with brake	C with brake
<b>A</b>	Basic motor without gear box	✓	✓	✓	✓
<b>B</b>	With planetary gear box	✓	✓		
<b>D</b>	With helical (spur) gear box, flange mounting	✓	✓		
<b>E</b>	With helical (spur) gear box, foot bracket mounting	✓	✓		
<b>F</b>	With worm gear box, flange mounting left side	✓	✓		
<b>G</b>	With worm gear box, flange mounting right side	✓	✓		
<b>H</b>	With worm gear box, foot bracket or universal mountings	✓	✓		

**Note:** This model code can not be used for creating new part numbers. All possible combinations between motor size, function and free speed are in all previous pages.

**Air motor use in the application is linked to the vanes material**  
 \* 0, D standard vanes for intermittent use, vanes are spring loaded  
 \* C, E "black" vanes for continuous use, vanes are spring loaded

**A: Free installation positions, basic motor**

**B: Free installation positions, planetary gear**

**D: Installation positions, helical gear and flange mounting**

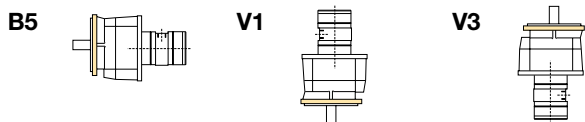

**E: Installation positions, helical gear and foot mounting**

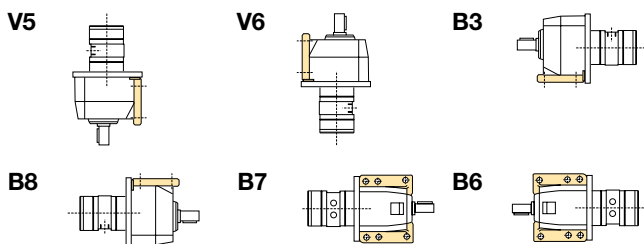

**F, G, H: Installation positions, worm gears**

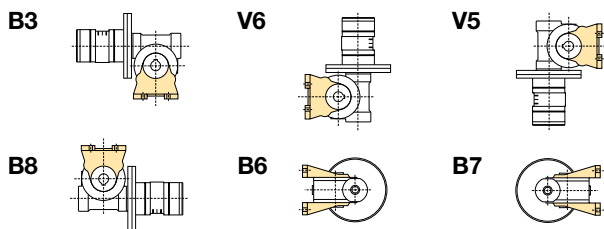

Installation position		Function						
		A	B	D	E	F	G	H
Free installation		✓	✓					
<b>Horizontal mounting</b>								
<b>B3</b>	Foot bottom				✓	✓	✓	✓
<b>B5</b>	Flange			✓				
<b>B6</b>	Foot left side				✓	✓	✓	✓
<b>B7</b>	Foot right side				✓	✓	✓	✓
<b>B8</b>	Foot top				✓	✓	✓	✓
<b>Vertical mounting</b>								
<b>V1</b>	Flange downward			✓				
<b>V3</b>	Flange upward			✓				
<b>V5</b>	Foot upward				✓	✓	✓	✓
<b>V6</b>	Foot downward				✓	✓	✓	✓

**Note:** Oil-bath gearboxes mean that the installation position must be decided in advance. The installation position determines the volume of oil in the gearbox and location of oil filling and drain plugs.

**Standard vanes (0, D):**

For intermittent lubrication-free operation. They can operate 70% of the time for up to 15 minutes without lubrication. With lubrication, these motors can operation 100% of the time.

**"Black" vanes (C, E):**

For continuous lubrication-free operation. (To obtain the longest possible service life, we recommend no oil in the air.)

# Parker Worldwide

## Europe, Middle East, Africa

**AE – United Arab Emirates,** Dubai  
Tel: +971 4 8127100  
parker.me@parker.com

**AT – Austria,** Wiener Neustadt  
Tel: +43 (0)2622 23501-0  
parker.austria@parker.com

**AT – Eastern Europe,** Wiener Neustadt  
Tel: +43 (0)2622 23501 900  
parker.easteurope@parker.com

**AZ – Azerbaijan,** Baku  
Tel: +994 50 2233 458  
parker.azerbaijan@parker.com

**BE/LU – Belgium,** Nivelles  
Tel: +32 (0)67 280 900  
parker.belgium@parker.com

**BG – Bulgaria,** Sofia  
Tel: +359 2 980 1344  
parker.bulgaria@parker.com

**BY – Belarus,** Minsk  
Tel: +48 (0)22 573 24 00  
parker.poland@parker.com

**CH – Switzerland,** Etoy  
Tel: +41 (0)21 821 87 00  
parker.switzerland@parker.com

**CZ – Czech Republic,** Klecany  
Tel: +420 284 083 111  
parker.czechrepublic@parker.com

**DE – Germany,** Kaarst  
Tel: +49 (0)2131 4016 0  
parker.germany@parker.com

**DK – Denmark,** Ballerup  
Tel: +45 43 56 04 00  
parker.denmark@parker.com

**ES – Spain,** Madrid  
Tel: +34 902 330 001  
parker.spain@parker.com

**FI – Finland,** Vantaa  
Tel: +358 (0)20 753 2500  
parker.finland@parker.com

**FR – France,** Contamine s/Arve  
Tel: +33 (0)4 50 25 80 25  
parker.france@parker.com

**GR – Greece,** Athens  
Tel: +30 210 933 6450  
parker.greece@parker.com

**HU – Hungary,** Budaörs  
Tel: +36 23 885 470  
parker.hungary@parker.com

**IE – Ireland,** Dublin  
Tel: +353 (0)1 466 6370  
parker.ireland@parker.com

**IL – Israel**  
Tel: +39 02 45 19 21  
parker.israel@parker.com

**IT – Italy,** Corsico (MI)  
Tel: +39 02 45 19 21  
parker.italy@parker.com

**KZ – Kazakhstan,** Almaty  
Tel: +7 7273 561 000  
parker.easteurope@parker.com

**NL – The Netherlands,** Oldenzaal  
Tel: +31 (0)541 585 000  
parker.nl@parker.com

**NO – Norway,** Asker  
Tel: +47 66 75 34 00  
parker.norway@parker.com

**PL – Poland,** Warsaw  
Tel: +48 (0)22 573 24 00  
parker.poland@parker.com

**PT – Portugal**  
Tel: +351 22 999 7360  
parker.portugal@parker.com

**RO – Romania,** Bucharest  
Tel: +40 21 252 1382  
parker.romania@parker.com

**RU – Russia,** Moscow  
Tel: +7 495 645-2156  
parker.russia@parker.com

**SE – Sweden,** Spånga  
Tel: +46 (0)8 59 79 50 00  
parker.sweden@parker.com

**SL – Slovenia,** Novo Mesto  
Tel: +386 7 337 6650  
parker.slovenia@parker.com

**TR – Turkey,** Istanbul  
Tel: +90 216 4997081  
parker.turkey@parker.com

**UA – Ukraine,** Kiev  
Tel: +48 (0)22 573 24 00  
parker.poland@parker.com

**UK – United Kingdom,** Warwick  
Tel: +44 (0)1926 317 878  
parker.uk@parker.com

**ZA – South Africa,** Kempton Park  
Tel: +27 (0)11 961 0700  
parker.southafrica@parker.com

## North America

**CA – Canada,** Milton, Ontario  
Tel: +1 905 693 3000

**US – USA,** Cleveland  
Tel: +1 216 896 3000

## Asia Pacific

**AU – Australia,** Castle Hill  
Tel: +61 (0)2-9634 7777

**CN – China,** Shanghai  
Tel: +86 21 2899 5000

**HK – Hong Kong**  
Tel: +852 2428 8008

**IN – India,** Mumbai  
Tel: +91 22 6513 7081-85

**JP – Japan,** Tokyo  
Tel: +81 (0)3 6408 3901

**KR – South Korea,** Seoul  
Tel: +82 2 559 0400

**MY – Malaysia,** Shah Alam  
Tel: +60 3 7849 0800

**NZ – New Zealand,** Mt Wellington  
Tel: +64 9 574 1744

**SG – Singapore**  
Tel: +65 6887 6300

**TH – Thailand,** Bangkok  
Tel: +662 186 7000

**TW – Taiwan,** Taipei  
Tel: +886 2 2298 8987

## South America

**AR – Argentina,** Buenos Aires  
Tel: +54 3327 44 4129

**BR – Brazil,** Sao Jose dos Campos  
Tel: +55 800 727 5374

**CL – Chile,** Santiago  
Tel: +56 2 623 1216

**MX – Mexico,** Toluca  
Tel: +52 72 2275 4200

### European Product Information Centre

Free phone: 00 800 27 27 5374

(from AT, BE, CH, CZ, DE, DK, EE, ES, FI, FR, IE, IL, IS, IT, LU, MT, NL, NO, PL, PT, RU, SE, SK, UK, ZA)

### Parker Hannifin Ltd.

Tachbrook Park Drive  
Tachbrook Park,  
Warwick, CV34 6TU  
United Kingdom  
Tel.: +44 (0) 1926 317 878  
Fax: +44 (0) 1926 317 855  
parker.uk@parker.com  
www.parker.com

