



aerospace  
climate control  
electromechanical  
filtration  
fluid & gas handling  
hydraulics  
**pneumatics**  
process control  
sealing & shielding



# P3X Lite Series Air Preparation System

G1/2 & G3/4 Body ported

Catalogue no. PDE2620TCUK February 2016



ENGINEERING YOUR SUCCESS.

# Table of Contents

---

Nano Mist .....	4
Popular combinations .....	5
Filters .....	6 - 7
Coalescing filters .....	8 - 9
Adsorber filters .....	10 - 11
Regulators .....	12 - 13
Filter regulators .....	14 - 15
Lubricators .....	16 - 17
Proportional Pressure Regulators .....	18 - 19
Combined Soft Start Dump Valves .....	20 - 21
Air Pilot Regulator .....	22 - 23
Modular slide valve .....	24
Modular manifold .....	24
Solenoid Coils .....	25
Accessories .....	26
Membrane Dryers .....	27 - 29

 **WARNING**

FAILURE OR IMPROPER SELECTION OR IMPROPER USE OF THE PRODUCTS AND/OR SYSTEMS DESCRIBED HEREIN OR RELATED ITEMS CAN CAUSE DEATH, PERSONAL INJURY AND PROPERTY DAMAGE.

This document and other information from Parker Hannifin Corporation, its subsidiaries and authorized distributors provide product and/or system options for further investigation by users having technical expertise. It is important that you analyze all aspects of your application and review the information concerning the product or system in the current product catalog. Due to the variety of operating conditions and applications for these products or systems, the user, through its own analysis and testing, is solely responsible for making the final selection of the products and systems and assuring that all performance, safety and warning requirements of the application are met. The products described herein, including without limitation, product features, specifications, designs, availability and pricing, are subject to change by Parker Hannifin Corporation and its subsidiaries at any time without notice.

**SALE CONDITIONS**

The items described in this document are available for sale by Parker Hannifin Corporation, its subsidiaries or its authorized distributors. Any sale contract entered into by Parker will be governed by the provisions stated in Parker's standard terms and conditions of sale (copy available upon request).

## The System

The P3X system allows units to be connected together, without the use of pipe connectors, saving space; providing constant mounting centres; whilst maintaining a modern aesthetically pleasing appearance.

The P3X Filters are specially designed to efficiently filter out rust, dirt, moisture and other impurities from compressed air lines. Operation is fully automatic with a minimum of pressure drop. Coalescing filters and adsorber filters for high purity air are also included in the P3X series.

The P3X Regulators are designed to provide quick response and accurate pressure regulation for the most demanding hi-flow industrial applications. The rolling diaphragm was designed for long trouble-free operation and will not rupture or tear under high cycle or other demanding applications.

The P3X mist lubricators are designed to provide lubrication for many general purpose applications in a pneumatic system.

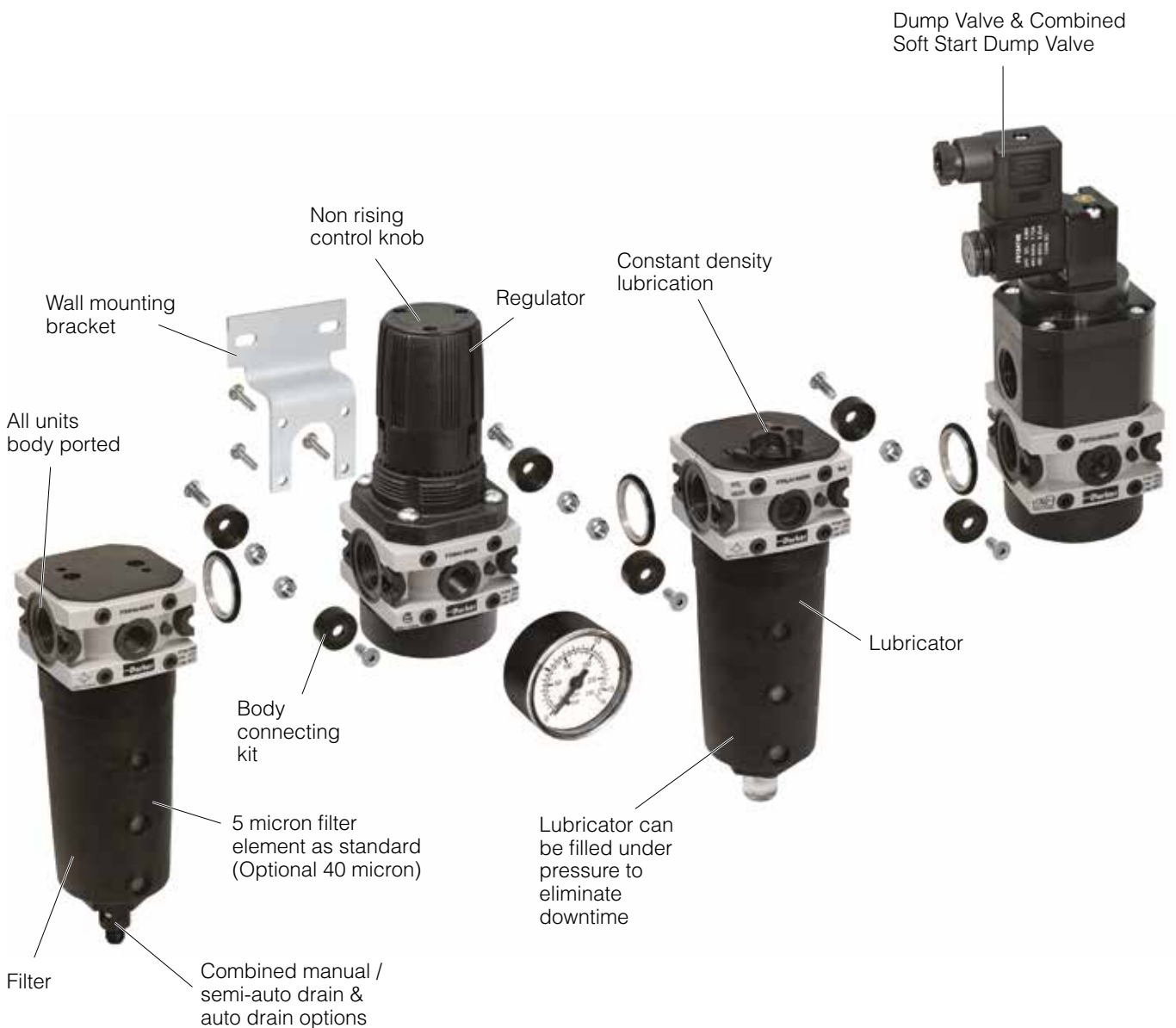

**New Technology**

The P3X Lite FRL system is constructed from ultra light weight technopolymers instead of the traditional aluminium or zinc die cast, this means that is up to 45% lighter than conventional units. This non-metal construction also means that the P3X Lite is corrosion free enabling it to be used in harsh industrial environments where anti freeze or aggressive synthetic oils are present.

The use of technopolymers in the design of P3X Lite has facilitated a universal body design, this has resulted in reducing the number of variants required to cover the full spectrum of applications. This can dramatically lower logistic costs and simplify stock holding for customers making the P3X Lite a very cost effective solution.



# Nano Mist

**New Nano Mist Technology,  
New Lubricator Concept.  
Self-Adjusting.**

With conventional lubricators, only the oil volume per time unit can be adjusted. If the demand changes, the quantity dispensed still remains constant.

The P3X Lite lubricator concept sets new benchmarks here. For the first time, the oil volume is automatically adjusted to the flow rate. This ensures that there is neither too little nor too much oil in the system, which leads to clear economic and ecological advantages. In addition, with conventional systems, the distance between the lubricator and the equipment has to be less than 8 meters. With larger distances, the dispensed oil is deposited as a wall flow. The new lubricator principle of the P3X Lite allows for distances of up to 40 meters. This opens up new scope for the design of even more efficient production systems.

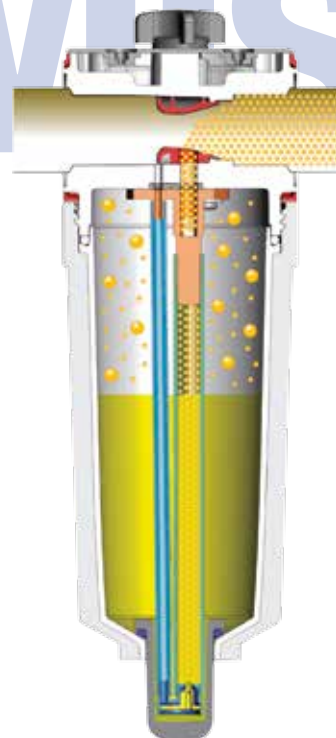

**Popular Combinations**

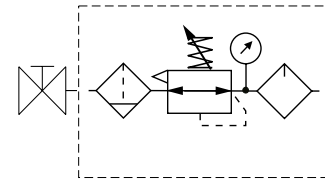

**Slide Valve + Filter/Regulator + Lubricator Combinations (50mg/m<sup>3</sup>)**  
**5 micron element, 8 bar Regulator + Gauge and Wall Mounting Brackets**

Port size	Combined Manual/Semi-Auto Drain	Flow dm <sup>3</sup> /s	Weight (g)	Auto Drain	Flow dm <sup>3</sup> /s	Weight (g)
G <sup>1</sup> / <sub>2</sub>	<b>P3XAA14GECNGPNW</b>	76	1300	<b>P3XAA14GEANGPNW</b>	76	1300
G <sup>3</sup> / <sub>4</sub>	<b>P3XAA16GECNGPNW</b>	77	1300	<b>P3XAA16GEANGPNW</b>	77	1300

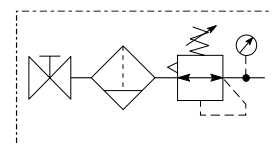

**Slide Valve + Filter/Regulator Combinations**  
**5 micron element, 8 bar Regulator + Gauge and Wall Mounting Brackets**

Port size	Combined Manual/Semi-Auto Drain	Flow dm <sup>3</sup> /s	Weight (g)	Auto Drain	Flow dm <sup>3</sup> /s	Weight (g)
G <sup>1</sup> / <sub>2</sub>	<b>P3XAN14GECNGW</b>	105	950	<b>P3XAN14GEANGW</b>	105	950
G <sup>3</sup> / <sub>4</sub>	<b>P3XAN16GECNGW</b>	106	950	<b>P3XAN16GEANGW</b>	106	950

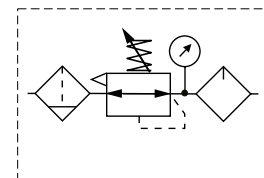

**Filter/Regulator + Lubricator Combinations (50mg/m<sup>3</sup>)**  
**5 micron element, 8 bar Regulator + Gauge and Wall Mounting Brackets**

Port size	Combined Manual/Semi-Auto Drain	Flow dm <sup>3</sup> /s	Weight (g)	Auto Drain	Flow dm <sup>3</sup> /s	Weight (g)
G <sup>1</sup> / <sub>2</sub>	<b>P3XCA14GECNGPNW</b>	76	1000	<b>P3XCA14GEANGPNW</b>	76	1000
G <sup>3</sup> / <sub>4</sub>	<b>P3XCA16GECNGPNW</b>	77	1000	<b>P3XCA16GEANGPNW</b>	77	1000

**Options:**

<b>P 3 X</b>				<b>G E</b>				<b>W</b>
Filter/Reg + Lubricator	<b>CA</b>	BSPP (G) <b>1</b>		Combined Manual/Semi Auto Drain	<b>C</b>	0 - 8 bar with gauge	<b>G</b>	
Slide valve + Filter/Reg	<b>AN</b>	NPT * <b>9</b>		Auto Drain	<b>A</b>	0 - 16 bar with gauge	<b>J</b>	
Slide valve + Filter/Reg + Lubricator	<b>AA</b>							
* NPT ports on request 1/2" size only		1/2 <b>4</b>		Non rise - Standard	<b>N</b>	(50mg/m <sup>3</sup> )	<b>PN</b>	Add only for options with lubricator
		3/4 <b>6</b>		Tamperproof - Lockable	<b>A</b>	(5mg/m <sup>3</sup> )	<b>SN</b>	

**Filter**



**Symbols**

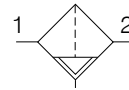

Manual / Semi auto drain

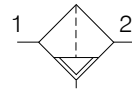

Auto drain

- Integral 1/2 or 3/4" ports
- 2 stage filtration
- High efficiency 5µ particulate element as standard
- Excellent water removal efficiency
- Low temperature -40°C with combined manual/semi - auto drain as standard

**Options:**

<b>P 3 X F A</b>	□	□	□	<b>G</b>	□	<b>N</b>																		
<table border="1" style="width: 100%; border-collapse: collapse;"> <tr> <td style="padding: 2px;">BSPP (G)</td> <td style="text-align: center; padding: 2px;"><b>1</b></td> </tr> <tr> <td style="padding: 2px;">NPT *</td> <td style="text-align: center; padding: 2px;"><b>9</b></td> </tr> </table>	BSPP (G)	<b>1</b>	NPT *	<b>9</b>	<table border="1" style="width: 100%; border-collapse: collapse;"> <tr> <td style="padding: 2px;">1/2</td> <td style="text-align: center; padding: 2px;"><b>4</b></td> </tr> <tr> <td style="padding: 2px;">3/4</td> <td style="text-align: center; padding: 2px;"><b>6</b></td> </tr> </table>	1/2	<b>4</b>	3/4	<b>6</b>	<table border="1" style="width: 100%; border-collapse: collapse;"> <tr> <td style="padding: 2px;">5 Micron Element Standard</td> <td style="text-align: center; padding: 2px;"><b>E</b></td> </tr> <tr> <td style="padding: 2px;">40 Micron Element Optional</td> <td style="text-align: center; padding: 2px;"><b>G</b></td> </tr> <tr> <td style="padding: 2px;">1 Micron Dust Filter</td> <td style="text-align: center; padding: 2px;"><b>2</b></td> </tr> </table>	5 Micron Element Standard	<b>E</b>	40 Micron Element Optional	<b>G</b>	1 Micron Dust Filter	<b>2</b>	<table border="1" style="width: 100%; border-collapse: collapse;"> <tr> <td style="padding: 2px;">Combined Manual/Semi Auto Drain</td> <td style="text-align: center; padding: 2px;"><b>C</b></td> </tr> <tr> <td style="padding: 2px;">Auto Drain</td> <td style="text-align: center; padding: 2px;"><b>A</b></td> </tr> </table>	Combined Manual/Semi Auto Drain	<b>C</b>	Auto Drain	<b>A</b>			
BSPP (G)	<b>1</b>																							
NPT *	<b>9</b>																							
1/2	<b>4</b>																							
3/4	<b>6</b>																							
5 Micron Element Standard	<b>E</b>																							
40 Micron Element Optional	<b>G</b>																							
1 Micron Dust Filter	<b>2</b>																							
Combined Manual/Semi Auto Drain	<b>C</b>																							
Auto Drain	<b>A</b>																							
<p>* NPT ports on request                      1/2" size only</p>																								

Port size	Description	Order Code	Flow dm <sup>3</sup> /s *	Max bar	Min temp °C	Max temp °C	Bowl capacity cm <sup>3</sup>	Height mm	Width mm	Depth mm	Weight g
1/2	Combined manual/semi auto drain	<b>P3XFA14EGCN</b>	55	16	-40	60	60	192	62	62	320
1/2	Auto drain	<b>P3XFA14EGAN</b>	55	16	-10	60	60	192	62	62	320
3/4	Combined manual/semi auto drain	<b>P3XFA16EGCN</b>	57	16	-40	60	60	192	62	62	320
3/4	Auto drain	<b>P3XFA16EGAN</b>	57	16	-10	60	60	192	62	62	320

\* flow with 6,3 bar inlet pressure and 0,5 pressure drop.

**Technical Information**

Fluid:	Compressed air
Maximum inlet pressure:	16 bar
Temperature range*:	
Auto drain:	-10°C to +60°C
Combined drain:	-40°C to +60°C
Particle removal:	1, 5 & 40 micron
Air quality:	Within ISO 8573-1 : 1991 Class 3 and 5 (particulates) Within ISO 8573-1 : 2001 Class 6 and 7 (particulates)
Typical flow with 5µm element 6,3 bar inlet pressure and 0.5 bar pressure drop:	1/2" size 55 dm <sup>3</sup> /s
Semi-auto drain: bowl pressure to close drain	0.8 bar
Auto drain: bowl pressure to close drain Operating range manual override facility	0.8 bar 0.8 to 16 bar
Bowl sump capacity:	60 cm <sup>3</sup>

\* Air supply must be dry enough to avoid ice formation at temperatures below +2°C

**Dimensions (mm)**

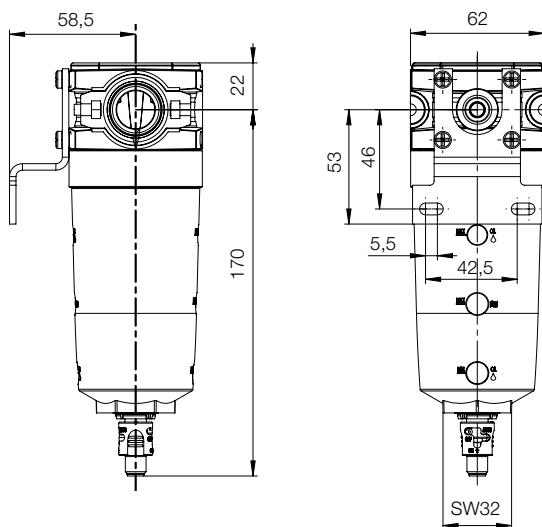

**Service kits**

Description	Order code
5 micron element kit	<b>P3XKA00ESE</b>
40 micron element kit	<b>P3XKA00ESG</b>
Bowl kit with combines manual/semi auto drain	<b>P3XKA00BSC</b>
Bowl kit with auto drain	<b>P3XKA00BSA</b>
1 micron element kit	<b>P3XKA00ES9</b>

**Material Specification**

Body:	High tech polymer
Sight glass:	Polypropylene
Body cover:	ABS
Element:	Sintered P.E.
Seals:	Nitrile NBR
Drains:	Manual / Semi-auto: Acetal Automatic: PA / Brass

**Flow characteristics**

**(1/2) 5 Micron Filter**

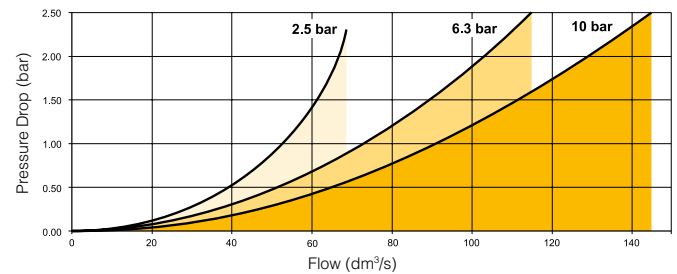

**(3/4) 5 Micron Filter**

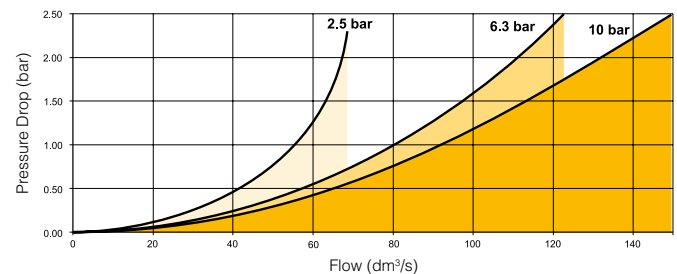

**Coalescing Filter**



- Integral 1/2 or 3/4 ports
- Removes liquid aerosols and sub micron particles
- Oil free air for critical applications, such as air gauging, pneumatic instrumentation and control

**Note:** To optimise the life of the coalescing element, it is advisable to install a P3XFA pre-filter with a 5 micron element upstream of the coalescing filter.

**Options:**

<b>P 3 X F A</b>									
	BSPP (G)	<b>1</b>	1/2	<b>4</b>	0.01 µm element with DPI standard	<b>D</b>	G		N
	NPT *	<b>9</b>	3/4	<b>6</b>			Combined Manual/Semi Auto Drain		<b>C</b>
							Auto Drain		<b>A</b>

\* NPT ports on request  
1/2" size only

Port size	Description	Order Code	Flow dm <sup>3</sup> /s *	Max bar	Min temp °C	Max temp °C	Bowl capacity cm <sup>3</sup>	Height mm	Width mm	Depth mm	Weight g
1/2	Coalescing Filter 0.01µm, Combined manual/semi auto drain	<b>P3XFA14DGCN</b>	24	16	-10	60	60	217	62	62	320
1/2	Coalescing Filter 0.01µm, auto drain	<b>P3XFA14DGAN</b>	24	16	-10	60	60	217	62	62	320
3/4	Coalescing Filter 0.01µm, Combined manual/semi auto drain	<b>P3XFA16DGCN</b>	24	16	-10	60	60	217	62	62	320
3/4	Coalescing Filter 0.01µm, auto drain	<b>P3XFA16DGAN</b>	24	16	-10	60	60	217	62	62	320

\* flow with 6,3 bar inlet pressure and 0,2 pressure drop.



**Technical Information**

Fluid:	Compressed air
Maximum inlet pressure:	16 bar
Temperature range*:	-10°C to +60°C
Media specifications:	
Coalescing efficiency	(0.3 to 0.6 micron particles): 99.97%
Max. oil carryover (PPM w/w):	0.008 mg/m <sup>3</sup>
Typical flow element @ 6,3 bar inlet pressure and 0.2 bar pressure drop:	16 dm <sup>3</sup> /s
Manual / Semi-auto drain:	
Bowl pressure to close drain	0.8 bar
Auto drain:	
bowl pressure to close drain	0.8 bar
Operating range manual override facility	0.8 to 16 bar
Bowl sump capacity:	60 cm <sup>3</sup>

\* Air supply must be dry enough to avoid ice formation at temperatures below +2°C

**Material Specification**

Body:	High tech polymer
Sight glass:	Polypropylene
Filter cover:	ABS
Coalescing element:	Borosilicate & Nano fibres
Top & bottom end cap:	Glass filled nylon - Black
Support cylinders:	Grade 430 stainless steel
Support media:	Polypropylene
Anti re-entrainment barrier:	Polyester
Ensapulate:	Epoxy resin / Hardener
Seals:	Nitrile NBR
Drains:	Manual / Semi-auto: Acetal
	Automatic: PA / Brass
Differential pressure indicator materials:	
Body:	Acetal
Internal parts:	Acetal
Spring:	Stainless steel
Seals:	Nitrile NBR
Screws:	Steel / zinc plated

**Dimensions (mm)**

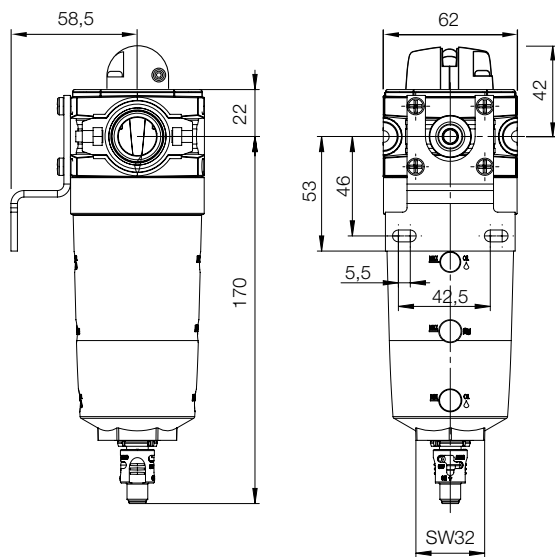

**Service kits**

Description	Order code
0.01 micron coalescing element kit	<b>P3XKA00ESC</b>
Bowl kit with combines manual/semi auto drain	<b>P3XKA00BSC</b>
Bowl kit with auto drain	<b>P3XKA00BSA</b>
Differential pressure indicator kit	<b>P3XKA00RQ</b>

**Flow characteristics**

**(1/2) 0.01µm Coalescing Filter Saturated**

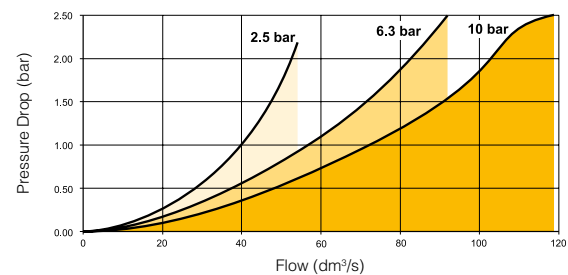

**(3/4) 0.01µm Coalescing Filter Saturated**

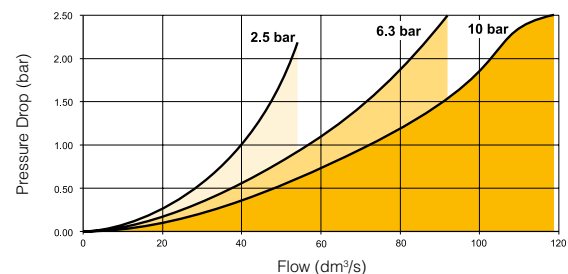

**Adsorber Filter**



- Integral 1/2 or 3/4 ports
- Adsorber activated carbon element removes oil vapours and most hydrocarbons

**Note:** To optimise the life of the adsorber element, it is advisable to install a P3X coalescing 0.01 µm filter upstream of the adsorber filter.

**Options:**

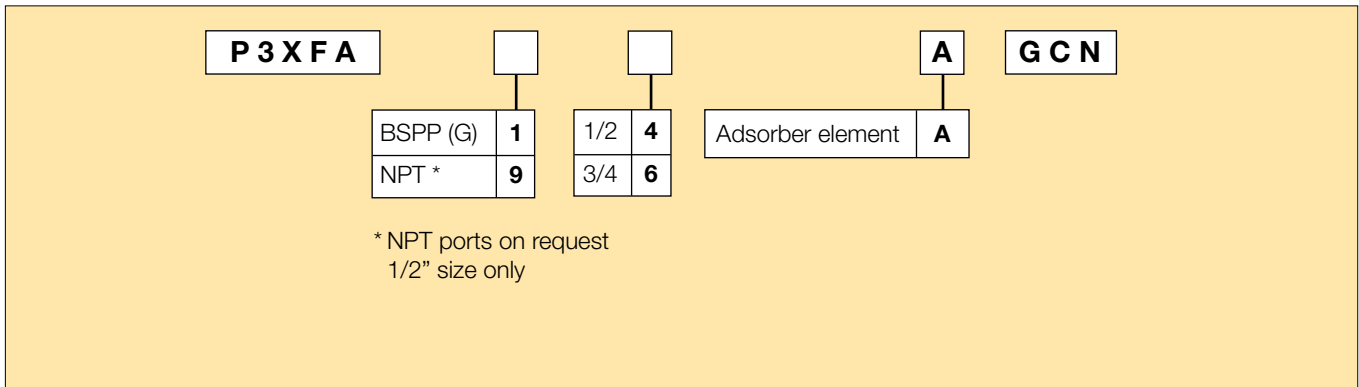

Port size	Description	Order Code	Flow dm <sup>3</sup> /s *	Max bar	Min temp °C	Max temp °C	Bowl capacity cm <sup>3</sup>	Height mm	Width mm	Depth mm	Weight g
1/2	Adsorber Filter, Manual / Semi-auto drain	<b>P3XFA14AGCN</b>	18	16	-10	60	60	192	62	62	320
3/4	Adsorber Filter, Manual / Semi-auto drain	<b>P3XFA16AGCN</b>	18	16	-10	60	60	192	62	62	320

\* flow with 6,3 bar inlet pressure and 0,2 pressure drop.

**Technical Information**

Fluid:	Compressed air	
Maximum inlet pressure:	16 bar	
Temperature range*:	-10°C to +60°C	
Typical flow at 6,3 bar inlet pressure and 0.2 bar pressure drop:	Adsorber	18 dm <sup>3</sup> /s
Manual / Semi-auto drain:	1/8" connection	
to close connection	0.8 bar	

\* Air supply must be dry enough to avoid ice formation at temperatures below +2°C

**Material Specification**

Body:	High tech polymer
Sight glass:	Polypropylene
Filter cover:	ABS
Adsorber element:	Activated carbon
Top & bottom endcap:	Glass filled nylon
Support cylinders:	Grade 430 stainless steel
Support media:	100% spun polypropylene
Support sock:	Polyester needlefelt
Encapsulant:	Epoxy resin / Hardener
Seals:	Nitrile NBR
Drain: Manual / Semi-auto	Acetal

**Dimensions (mm)**

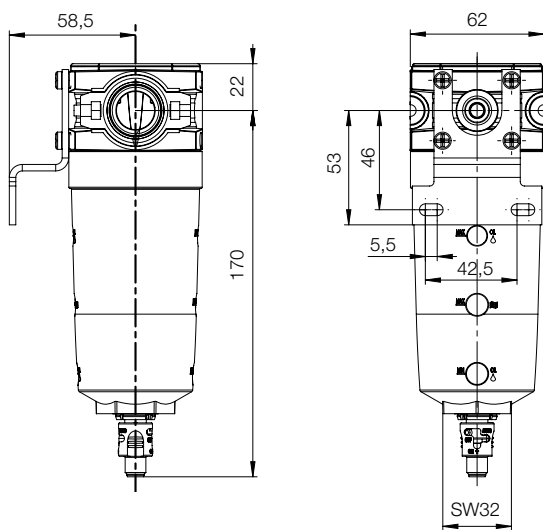

**Flow characteristics**

**(1/2) Adsorber Filter**

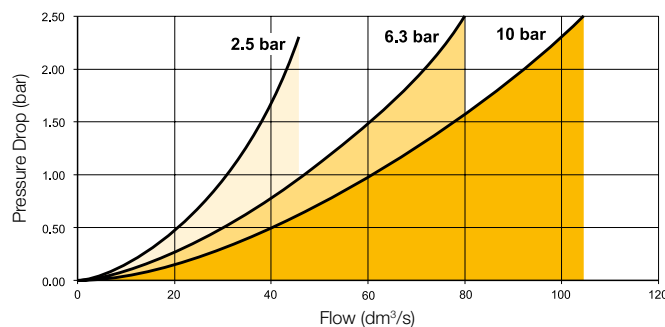

**(3/4) Adsorber Filter**

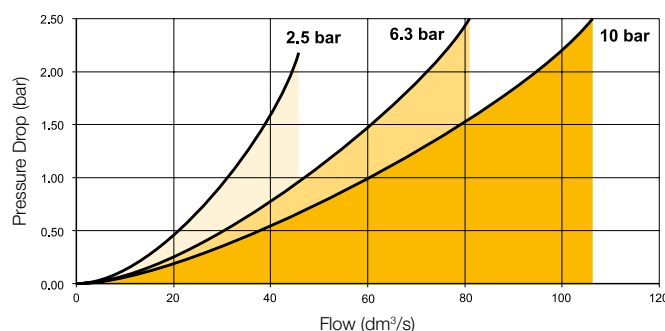

**Service kits**

Description	Order code
Adsorber element kit	<b>P3XKA00ESA</b>
Bowl kit with manual drain	<b>P3XKA00BSC</b>

**Regulator**



**Symbols**

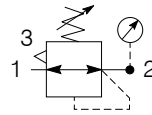

Self relieving regulator with gauge

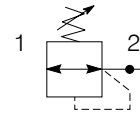

Non relieving regulator

- Integral 1/2 or 3/4 ports
- Secondary pressure ranges 8 & 16 bar
- Rolling diaphragm for extended life
- Secondary aspiration plus rolling diaphragm provides quick response and accurate pressure regulation.
- Optional tamperproof regulator, up to x 3 padlocks
- Relieving & Non-relieving types
- Low temperature -40°C as standard

**Options:**

<b>P 3 X R A</b>	□	□	□	□	□	□	<b>N</b>
BSPP (G) <b>1</b>	1/2 <b>4</b>	Relieving <b>B</b>	Non rise - standard <b>N</b>	0 - 4 bar No Gauge <b>L</b>			
NPT * <b>9</b>	3/4 <b>6</b>	Non-relieving <b>N</b>	Tamperproof - Lockable <b>A</b>	0 - 8 bar No Gauge <b>N</b>			
				0 - 16 bar No Gauge <b>H</b>			
				0 - 4 bar Gauge <b>M</b>			
				0 - 8 bar Gauge <b>G</b>			
				0 - 16 bar Gauge <b>J</b>			

\* NPT ports on request  
 1/2" size only

Port size	Description	Order Code	Flow dm <sup>3</sup> /s *	Max bar	Min temp °C	Max temp °C	Height mm	Width mm	Depth mm	Weight g
1/2	8 bar relieving	<b>P3XRA14BNNN</b>	122	16	-40	60	150	62	62	360
1/2	8 bar relieving + pressure gauge	<b>P3XRA14BNGN</b>	122	16	-10	60	150	62	95	410
3/4	8 bar relieving	<b>P3XRA16BNNN</b>	134	16	-40	60	150	62	62	360
3/4	8 bar relieving + pressure gauge	<b>P3XRA16BNGN</b>	134	16	-10	60	150	62	95	410
1/2	8 bar relieving with tamperproof facility	<b>P3XRA14BANN</b>	122	16	-40	60	158	62	62	360
1/2	8 bar relieving with tamperproof facility + pressure gauge	<b>P3XRA14BAGN</b>	122	16	-10	60	158	62	95	410
3/4	8 bar relieving with tamperproof facility	<b>P3XRA16BANN</b>	134	16	-40	60	158	62	62	360
3/4	8 bar relieving with tamperproof facility + pressure gauge	<b>P3XRA16BAGN</b>	134	16	-10	60	158	62	95	410

\* flow with 10 bar inlet pressure, 6,3 bar set pressure and 1 bar pressure drop.  
 Tamperproof regulator will require lock kit (on opposite page) to lock regulator.

**Technical Information**

Fluid:	Compressed air	
Maximum inlet pressure:	16 bar	
Temperature range*:	-40°C to +60°C	
Typical flow with 10 bar inlet pressure, 6.3 bar set pressure and 1 bar pressure drop:	1/2"	122 dm <sup>3</sup> /s
	3/4"	134 dm <sup>3</sup> /s
Gauge port ( x 2 ):	1/4"	

\* Air supply must be dry enough to avoid ice formation at temperatures below +2°C

**Material Specification**

Body:	High tech polymer
Bonnet:	High tech polymer
Regulator cover:	ABS
Control Knob:	Polyamide
Valve:	Brass / Nitrile
Seals:	Nitrile NBR
Screws:	Stainless steel

**Dimensions (mm)**

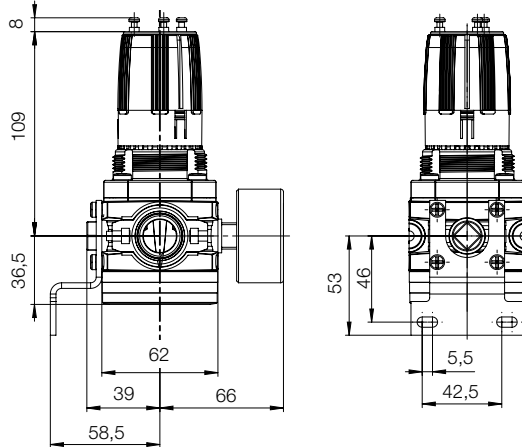

**Service kits**

Description	Order code
Wall bracket - Stainless steel	<b>P3XKA00MW</b>
Panel mounting nut	<b>P3XKA00MM</b>
Key lock	<b>P3XKA00AS</b>
Diaphragm kit (relieving type)	<b>P3XKA00RR</b>
Diaphragm kit (non-relieving type)	<b>P3XKA00RN</b>

**Lockable Tamperproof Kit** (up to x 3 padlocks)

This facilitates the tamperproofing of the Regulator and Filter-Regulator units. (On request)



	Order code
1 Padlock each	<b>P3XKA00AS</b>

**Flow characteristics**

**Regulation characteristics: (1/2)**

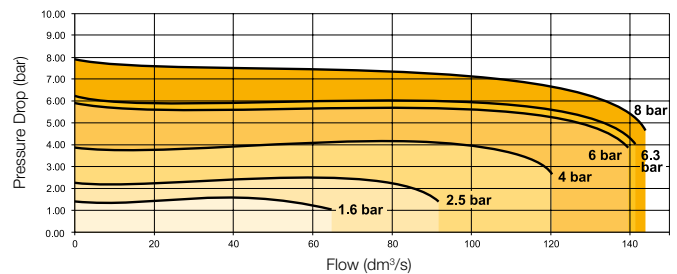

**Regulation characteristics: (3/4)**

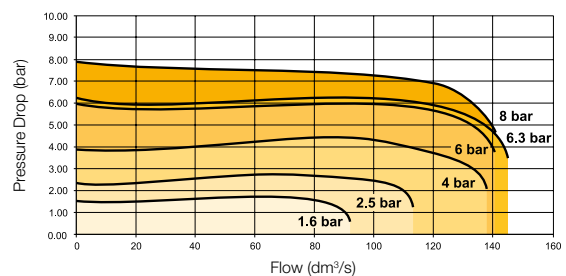

**Filter-Regulator**



**Symbols**

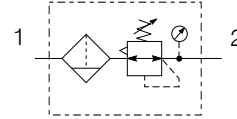

- Integral 1/2 or 3/4 ports
- High efficiency 5 micron element as standard
- Excellent water removal efficiency
- Secondary pressure ranges 8 and 16 bar
- Rolling diaphragm for extended life
- Secondary aspiration plus balanced poppet provides quick response and accurate pressure regulation.
- Low temperature -40°C with combined manual/semi - auto drain as standard

**Options:**

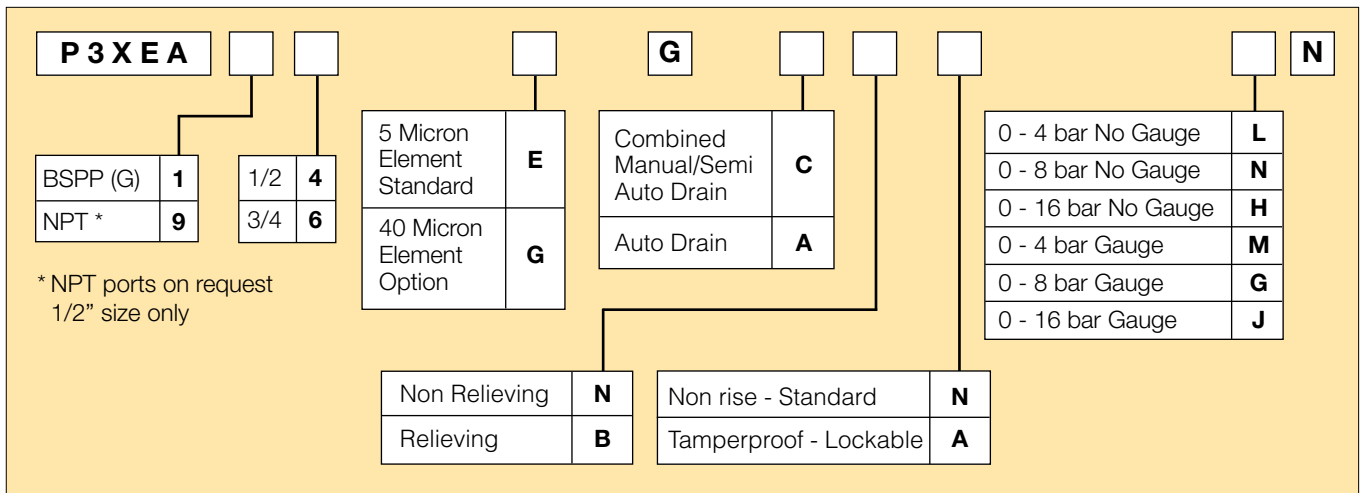

Port size	Description	Order Code	Flow dm <sup>3</sup> /s *	Max bar	Min temp °C	Max temp °C	Bowl capacity cm <sup>3</sup>	Height mm	Width mm	Depth mm	Weight g
1/2	8 bar, relieving, Combined manual/semi auto drain	<b>P3XEA14EGCBNNN</b>	111	16	-40	60	60	280	62	62	500
1/2	8 bar relieving, auto drain	<b>P3XEA14EGABNNN</b>	111	16	-10	60	60	280	62	62	500
1/2	8 bar, relieving, gauge Combined manual/semi auto drain	<b>P3XEA14EGCBNGN</b>	111	16	-10	60	60	280	62	62	550
1/2	8 bar relieving, gauge, auto drain	<b>P3XEA14EGABNGN</b>	111	16	-10	60	60	280	62	62	550
3/4	8 bar, relieving, Combined manual/semi auto drain	<b>P3XEA16EGCBNNN</b>	113	16	-40	60	60	280	62	62	500
3/4	8 bar relieving, auto drain	<b>P3XEA16EGABNNN</b>	113	16	-10	60	60	280	62	62	500
3/4	8 bar, relieving, gauge Combined manual/semi auto drain	<b>P3XEA16EGCBNGN</b>	113	16	-10	60	60	280	62	62	550
3/4	8 bar relieving, gauge, auto drain	<b>P3XEA16EGABNGN</b>	113	16	-10	60	60	280	62	62	550

\* flow with 10 bar inlet pressure, 6,3 bar set pressure and 1 bar pressure drop.

**Technical Information**

Fluid:	Compressed air
Maximum inlet pressure:	16 bar
Temperature range*:	
Auto drain:	-10°C to +60°C
Combined drain:	-40°C to +60°C
Particle removal:	5 micron and 40 micron
Air quality:	Within ISO 8573-1 : 1991 Class 3 and 5 (particulates) Within ISO 8573-1 : 2001 Class 6 and 7 (particulates)
Typical flow with 10 bar inlet pressure 6,3 bar set pressure and 1 bar pressure drop 106 dm <sup>3</sup> /s	
Manual / Semi-auto drain: pressure to close drain	0.8 bar
Auto drain:	
bowl pressure to close drain	0.8 bar
Operating range manual override facility	0.8 to 16 bar
Bowl sump capacity:	60 cm <sup>3</sup>
Gauge ports ( x 2 ):	1/4"

\* Air supply must be dry enough to avoid ice formation at temperatures below +2°C

**Dimensions (mm)**

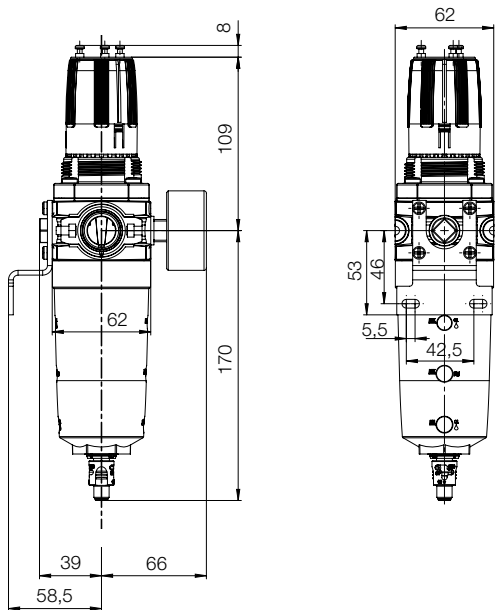

**Service kits**

Description	Order code
5 micron element kit	<b>P3XKA00ESE</b>
40 micron element kit	<b>P3XKA00ESG</b>
Bowl kit with combined manual/semi auto drain	<b>P3XKA00BSC</b>
Bowl kit with auto drain	<b>P3XKA00BSA</b>
Tamper-proof knob kit (keylock)	<b>P3XKA00AS</b>
Diaphragm kit (relieving type)	<b>P3XKA00RR</b>
Diaphragm kit (non-relieving type)	<b>P3XKA00RN</b>
Wall bracket kit - Stainless steel	<b>P3XKA00MW</b>
Panel mount nut	<b>P3XKA00MM</b>

**Material Specification**

Body:	High tech polymer
Sight glass:	Polypropylene
Body cover:	ABS
Element:	Sintered P.E.
Seals:	Nitrile NBR
Drains:	Manual / Semi-auto: Acetal Automatic: PA / Brass
Bonnet:	High tech polymer
Control knob:	Polyamide
Valve:	Brass / Nitrile
Screws:	Stainless steel

**Flow characteristics**

**(1/2) 5 Micron Filter/Regulator**

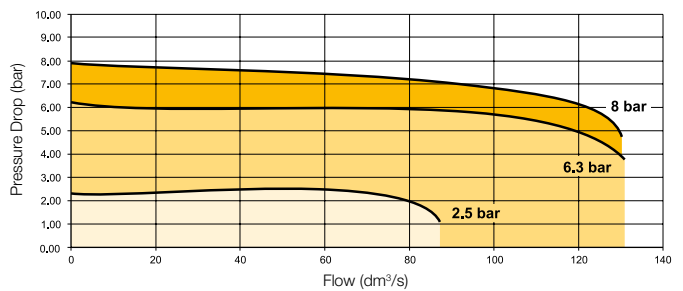

**(3/4) 5 Micron Filter/Regulator**

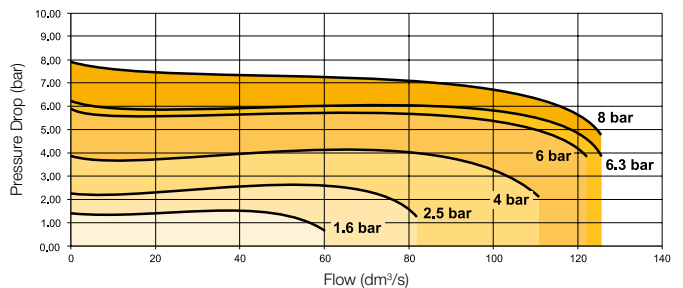

**Lubricator**



**Symbols**

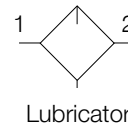

- Integral 1/2 or 3/4 ports
- Proportional oil delivery over a wide range of air flows.
- No adjustment necessary (self adjusting)
- Fill from top under system pressure

**Options:**

<b>P 3 X L A</b>	□	□	□	<b>G N N</b>												
* NPT ports on request 1/2" size only	<table border="1"> <tr><td>BSPP (G)</td><td style="text-align: center;"><b>1</b></td></tr> <tr><td>NPT *</td><td style="text-align: center;"><b>9</b></td></tr> </table>	BSPP (G)	<b>1</b>	NPT *	<b>9</b>	<table border="1"> <tr><td>1/2</td><td style="text-align: center;"><b>4</b></td></tr> <tr><td>3/4</td><td style="text-align: center;"><b>6</b></td></tr> </table>	1/2	<b>4</b>	3/4	<b>6</b>	<table border="1"> <tr><td>5 mg/m<sup>3</sup></td><td style="text-align: center;"><b>S</b><sup>1)</sup></td></tr> <tr><td>50 mg/m<sup>3</sup></td><td style="text-align: center;"><b>P</b><sup>2)</sup></td></tr> </table>	5 mg/m <sup>3</sup>	<b>S</b> <sup>1)</sup>	50 mg/m <sup>3</sup>	<b>P</b> <sup>2)</sup>	
BSPP (G)	<b>1</b>															
NPT *	<b>9</b>															
1/2	<b>4</b>															
3/4	<b>6</b>															
5 mg/m <sup>3</sup>	<b>S</b> <sup>1)</sup>															
50 mg/m <sup>3</sup>	<b>P</b> <sup>2)</sup>															

Port size	Description	Order Code	Flow dm <sup>3</sup> /s *	Max bar	Min temp °C	Max temp °C	Bowl capacity cm <sup>3</sup>	Height mm	Width mm	Depth mm	Weight g
1/2	Oil mist, fill under pressure (50mg/m <sup>3</sup> )	<b>P3XLA14PGNN</b>	78	16	-10	60	90	195	62	62	300
3/4	Oil mist, fill under pressure (50mg/m <sup>3</sup> )	<b>P3XLA16PGNN</b>	78	16	-10	60	90	195	62	62	300
1/2	Oil mist, fill under pressure (5mg/m <sup>3</sup> )	<b>P3XLA14SGNN</b>	78	16	-10	60	90	195	62	62	300
3/4	Oil mist, fill under pressure (5mg/m <sup>3</sup> )	<b>P3XLA16SGNN</b>	78	16	-10	60	90	195	62	62	300

\* Flow with 6,3 bar inlet pressure and 0,5 pressure drop.

<sup>1)</sup> Best for pre-lubricated pneumatic components (e.g. rodless cylinder, actuators, valves etc.)

<sup>2)</sup> Best for components which require effective lubrication (e.g. vane driven pneumatic motors / air tools etc.)



**Technical Information**

Fluid:	Compressed air
Maximum inlet pressure:	16 bar
Temperature range*:	-10°C to +60°C

\* Air supply must be dry enough to avoid ice formation at temperatures below +2° C  
 Low flow start point (lubrication pick-up): at 6.3bar inlet pressure 7 dm<sup>3</sup>/s  
 Typical flow with 6.3bar inlet pressure and 0.5 bar pressure drop: 78 dm<sup>3</sup>/s

**Note :** Fill lubricant from top only

**Material Specification**

Body:	High tech polymer
Bowl sight glass:	Polypropylene
Sight dome:	PA (Nylon)
Lubricator cover:	ABS
Seals:	Nitrile NBR

**Dimensions (mm)**

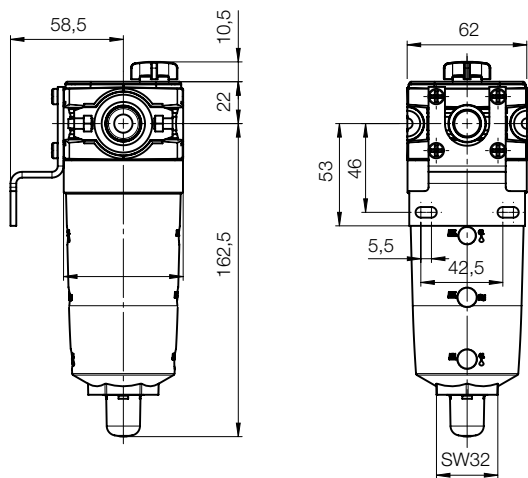

**Service kits**

Description	Order code
Bowl kit	<b>P3XKA00BSN</b>
Refill plug	<b>P3XKA00PL</b>
Oil VG15 - 100ml	<b>P3XKA00PPA</b>

**Flow characteristics**

**(1/2) Lubricator**

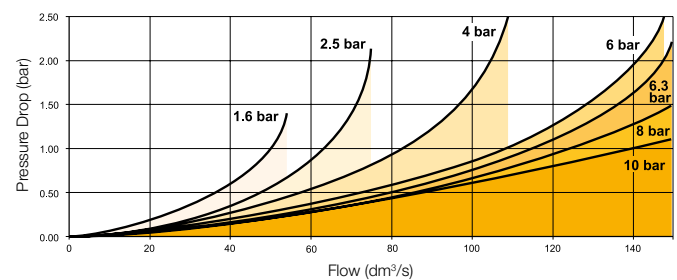

**(3/4) Lubricator**

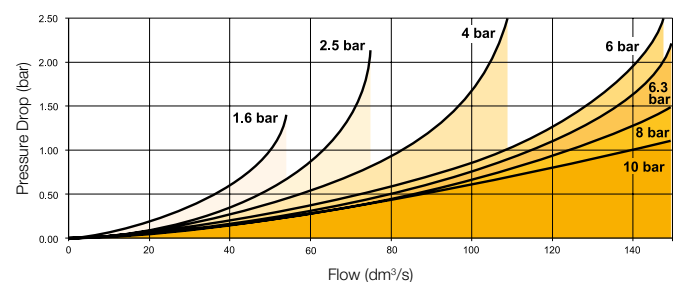

**Proportional Pressure Regulator**



- Integral 1/2" or 3/4" ports (BSPP & NPT)
- Accurate output pressure
- Very fast response times
- Robust but lightweight design.

**Options:**

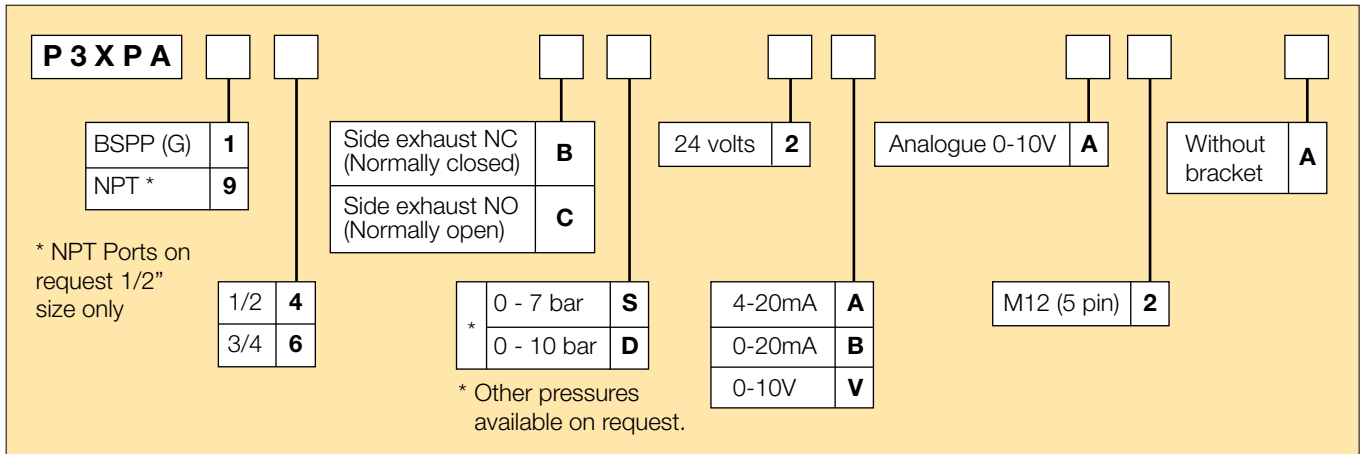

**Popular options:**

Port size	Description	Order Code	Control signal	Output signal	Output pressure	Weight kg
1/2	Normally closed	<b>P3XPA14BD2VA2A</b>	0 - 10 V	0 - 10 V	0 - 10 bar	0.75
3/4	Normally closed	<b>P3XPA16BD2VA2A</b>	0 - 10 V	0 - 10 V	0 - 10 bar	0.75

**Technical Information**

Operating pressure range	P <sup>1</sup> min	1 bar
Inlet pressure <sup>1)</sup>	P <sup>1</sup> max	16 bar
Operating pressure range	P <sup>2</sup> min	0.2 bar
Outlet pressure	P <sup>2</sup> max	10 bar
Operating Temperature	0°C to +50°C	
Maximum Flow <sup>2)</sup>	Q <sub>n</sub>	dm <sup>3</sup> /s 160
Hysteresis	P <sup>2</sup> max	< 1%
Repeatability	P <sup>2</sup> max	< 0.5%
Sensitivity	P <sup>2</sup> max	< 0.5%
Linearity	P <sup>2</sup> max	< 1%
Nominal voltage	U <sub>n</sub> V DC	24V = ±10%
Residual ripple	10%	
Power consumption	I <sub>Bmax</sub>	0.15 A
Set value input	U <sub>w</sub> V	0 - 10
	I mA	0 - 20
	I mA	4 - 20
Input resistance	R <sub>E</sub>	243 K $\Omega$
Actual valve output	U <sub>x</sub>	0 - 10 V
Output current	I <sub>Amax</sub>	10 mA
Degree of protection	IP65 to DIN 40050, EN 60529	

1)  $p_1 > p_2 + 10\% p_2$

2) at  $p_1 - 10$  bar to  $p_2 - 6.3$  bar

**Dimensions (mm)**

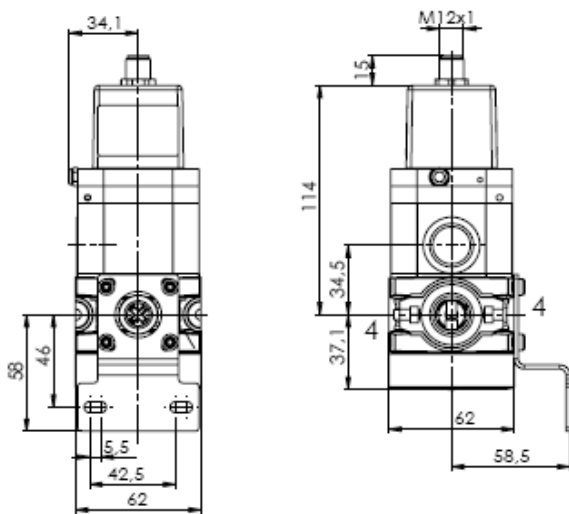

\* Two opposite gauge ports G1/4, plug screw mounted

\*\* Connection for 5-pin plug M12 x 1

\*\*\* Exhaust port 1/2"

**Material Specification**

Body:	High tech polymer
Booster valve:	Brass / Nitrile
Standard seals:	NBR
Body cover screws:	Steel / zinc plated
Body Cover:	Aluminium
Pilot piston:	Aluminium / Nitrile
Exhaust piston:	Brass / Nitrile
Electronic cover:	Zinc

**Connection diagram**

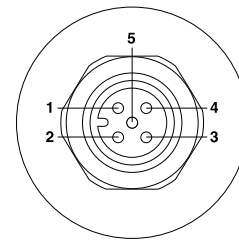

**Connector M12 x 1**

**Pin 1:**  
 Power supply  
 Plus +24 V DC ± 10%  
 0.15 A  
 Residual ripple 10%

**Pin 2:**  
 Power supply 0 V  
 Reference and mass capacity  
 for set value and actual value

**Pin 3:**  
 Set value input  
 0 - 10 V

**Pin 4:**  
 0 V set signal  
 (connected on board  
 with pin 2 as standard)

**Pin 5:**  
 Analogue actual value output  
 0 - 10 V  
 Tolerance ± 0.15 V

**Flow characteristics**

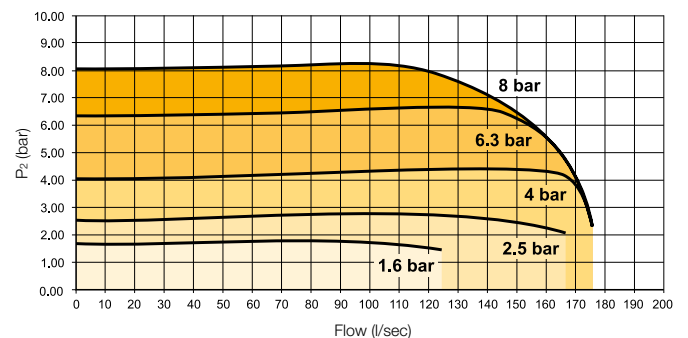

**Dump Valve & Combined Soft Start  
 Dump Valve**



**Symbols**

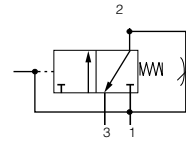

- Modular design with 1/2" & 3/4" integral ports (BSPP or NPT)
- Provides for the safe introduction of pressure
- Automatically dumps downstream pressure on the loss of pilot signal
- Adjustable slow start
- Solenoid or air pilot options
- High flow & exhaust capability

P3X Series Combined Soft Start/Dump Valves, provide for the safe introduction of pressure to machines or systems. Soft Start/Dump Valves when set, allow the pressure to gradually build to the set point before fully opening to deliver full flow at line pressure.

The controlled introduction of pressure can be an important safety factor and prevent damage to tooling when air pressure is introduced at machine or system start up.

**Options:**

**P 3 X**    **A**    **N**    **Solenoid type only**

Combined soft start dump valve	<b>T</b>	External air pilot	<b>P</b>	None (operator is fitted to valve)	<b>0</b>	Solenoid / coil not fitted	<b>000</b>
Dump valve	<b>D</b>	Solenoid pilot	<b>S</b>	30mm CNOMO coil (Form connection)	<b>A</b>	24V DC	<b>2CN</b>
BSPP (G)	<b>1</b>	30mm operator	<b>C</b>	22mm coil (Form connection)	<b>B</b>		
NPT *	<b>9</b>	Threaded air pilot	<b>P</b>	30mm CNOMO coil (M12 connection)	<b>D</b>		
				22mm coil (M12 connection)	<b>E</b>		

\* NPT Ports on request 1/2" size only

**Combined soft start dump valve**

Port size	Description	Order Code	Flow dm <sup>3</sup> /s	Max bar	Min temp °C	Max temp °C	Height mm	Width mm	Depth mm	Weight kg
1/2	Solenoid operated (not included)	<b>P3XTA14SCN0000</b>	80	16	-10	60	144	62	62	0.75
1/2	24VDC 22mm coil	<b>P3XTA14SCNB2CN</b>	80	10	-10	60	174	88	62	0.75
1/2	24VDC 30mm coil	<b>P3XTA14SCNA2CN</b>	80	16	-10	60	174	88	62	0.75
1/2	Air pilot operated	<b>P3XTA14PPN</b>	80	16	-10	60	127.5	62	62	0.75
3/4	Solenoid operated (not included)	<b>P3XTA16SCN0000</b>	88	16	-10	60	144	62	62	0.75
3/4	24VDC 22mm coil	<b>P3XTA16SCNB2CN</b>	88	10	-10	60	174	88	62	0.75
3/4	24VDC 30mm coil	<b>P3XTA16SCNA2CN</b>	88	16	-10	60	174	88	62	0.75
3/4	Air pilot operated	<b>P3XTA16PPN</b>	88	16	-10	60	127.5	62	62	0.75

**Technical Information**

Fluid:	Compressed air
Maximum pressure Solenoid operated 22mm coil:	10 bar
Maximum pressure Solenoid operated 30mm coil:	16 bar
Minimum operating pressure:	2 bar
Temperature range* Solenoid operated:	-10 <sup>o</sup> to + 60 <sup>o</sup> C
Temperature range* Air Pilot operated:	-10 <sup>o</sup> to + 60 <sup>o</sup> C
Air Pilot port:	1/8"
Exhaust port:	1/2"
Gauge port:	1/4"
Typical flow with 6.3bar inlet pressure and 1 bar pressure drop:	1/2" 80 dm <sup>3</sup> /s
	3/4" 80 dm <sup>3</sup> /s

\* Air supply must be dry enough to avoid ice formation at temperatures below +2°C  
 Snap pressure: Full flow when downstream pressure reaches 50% of the inlet pressure

**Material Specification**

Body:	Aluminium
Body cover:	ABS
Valve:	Brass / NBR composite
Pilot valve booster:	Aluminium
Seals:	Nitrile NBR

**Solenoid coils**

For Solenoid coil information refer to page 25

**Dimensions (mm)**

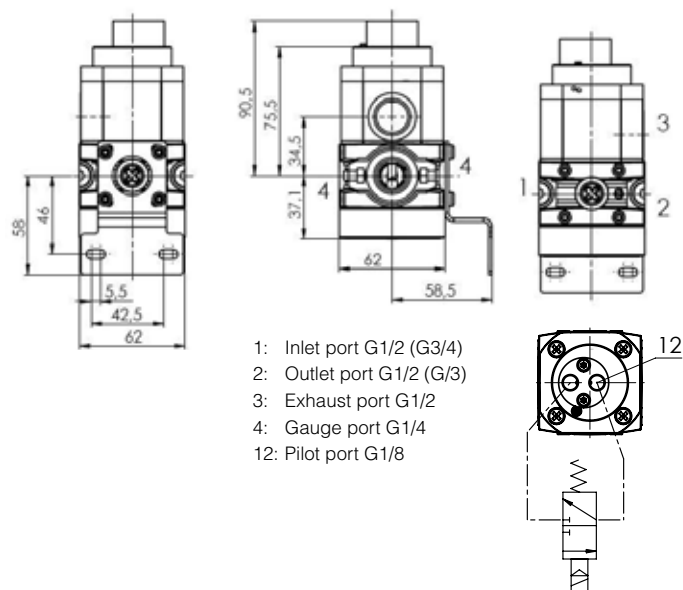
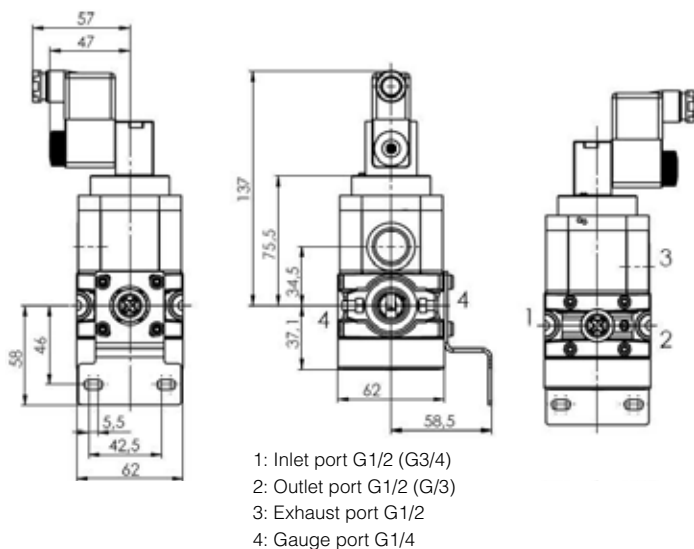

**Flow characteristics**

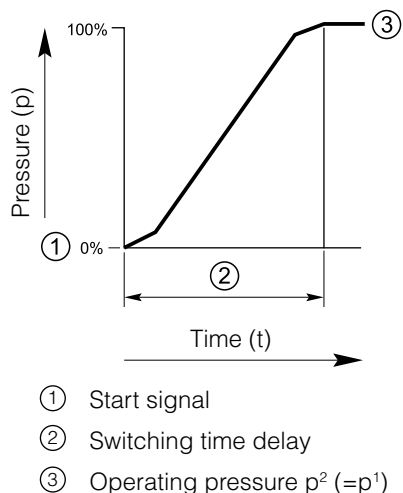

**Soft Start Dump Valve 24v 1/2" Port**

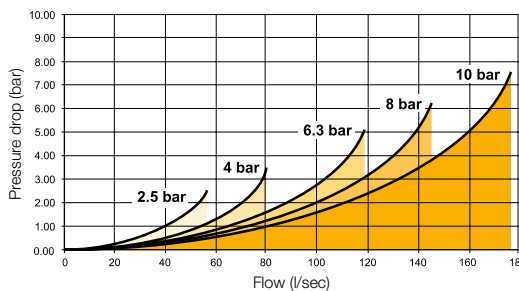

**Pilot Operated Regulator**



**Symbols**

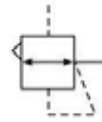

- Integral G1/2" or G3/4" ports
- G1/8" air pilot signal port
- Pilot controlled regulators can be mounted "out of reach" with pilot regulator installed in a convenient location
- Constant bleed control for accurate pressure control
- Balanced poppet provides quick response
- High flow
- Quick exhaust and high relief capacity through full 1/2" ported orifice

**Options:**

<b>P 3 X R A</b>			<b>B P P N</b>
BSPP (G)	<b>1</b>	1/2	<b>4</b>
NPT *	<b>9</b>	3/4	<b>6</b>

\* NPT ports on request  
 1/2" size only

Port size	Description	Order Code	Flow dm <sup>3</sup> /s	Max bar	Min temp °C	Max temp °C	Height mm	Width mm	Depth mm	Weight kg
1/2	Pilot operated regulator	<b>P3XRA14BPPN</b>	122	16	-40	60	150	62	62	360
3/4	Pilot operated regulator	<b>P3XRA16BPPN</b>	134	16	-40	60	150	62	62	360

\* flow with 10 bar inlet pressure, 6,3 bar set pressure and 1 bar pressure drop.

**Technical Information**

Fluid:	Compressed air
Maximum inlet pressure:	16 bar
Temperature range*:	-40°C to +60°C
Typical flow with 10 bar inlet pressure, 6.3 bar set pressure and 1 bar pressure drop:	1/2" 122 dm <sup>3</sup> /s 3/4" 134 dm <sup>3</sup> /s
Gauge port ( x 2 ):	1/4"
Pilot port:	1/8"

\* Air supply must be dry enough to avoid ice formation at temperatures below +2°C

**Material Specification**

Body:	High tech polymer
Body top:	Aluminium
Valve:	Brass / Nitrile
Seals:	Nitrile NBR
Screws:	Stainless steel

**Dimensions (mm)**

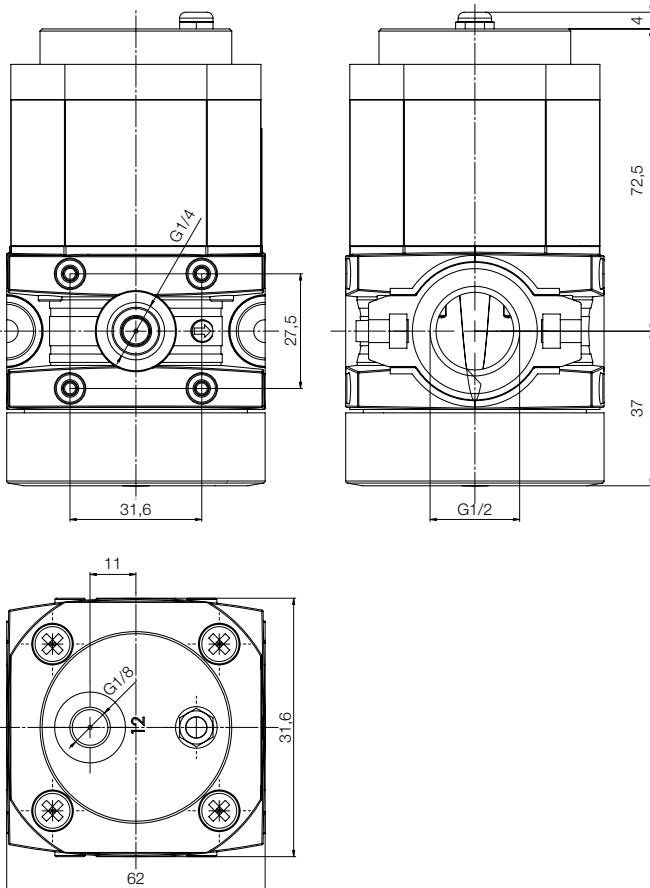

**Flow characteristics**

**Regulation characteristics: (1/2)**

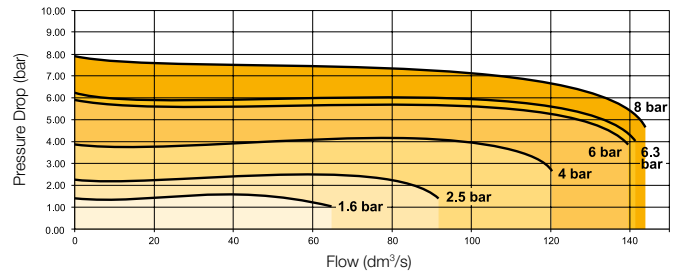

**Regulation characteristics: (3/4)**

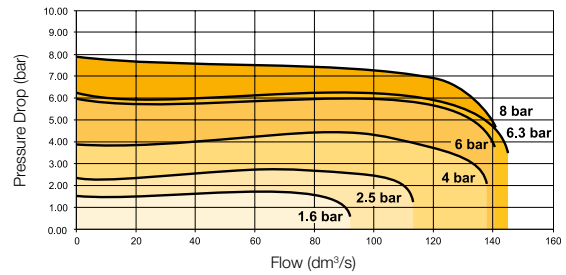

**Service kits**

Description	Order code
Wall bracket - Stainless steel	<b>P3XKA00MW</b>

**Modular Slide Valve**

**Symbol**

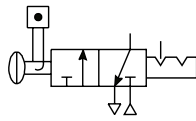

- Padlockable.
- When the inlet pressure is turned off the downstream vents through the exhaust port.

P3X Series Slide Valves provide shut off line pressure to prevent unauthorised adjustment.

**Options:**

<b>P 3 X</b>	<b>V A</b>			<b>LS N</b>
BSPP (G)	<b>1</b>	G1/2	<b>4</b>	
NPT *	<b>9</b>	G3/4	<b>6</b>	

\* NPT ports on request (1/2" size only)

**Technical Information**

Operating Temperature:	-10°C to +60°C	
Maximum Supply Pressure:	16 bar	
Weight (g):	1/2	300g
	3/4	300g

**Material specification:**

Body:	High tech polymer
Handle:	Polyamide
Seals:	Nitrile NBR
Exhaust muffler:	Sintered bronze

**Dimensions (mm)**

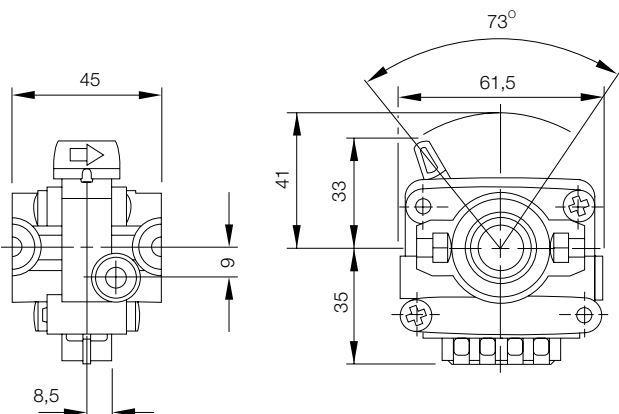

**Modular Manifold**



P3X Series Manifolds, provide up to 2 extra outlet ports, they may be assembled at any position in a combination e.g. before the lubricator to provide oil free take off or at the end of a combination to provide extra outlet ports.

Description	Order code BSPP	Order code NPT	Weight (g)
G1/2"	<b>P3XMA1V0N</b>	<b>P3XMA9V0N</b>	170
G3/4"	<b>P3XMA160N</b>		170

**Material specification:**

Body:	High tech polymer
Manifold Cover:	ABS

**Dimensions (mm)**

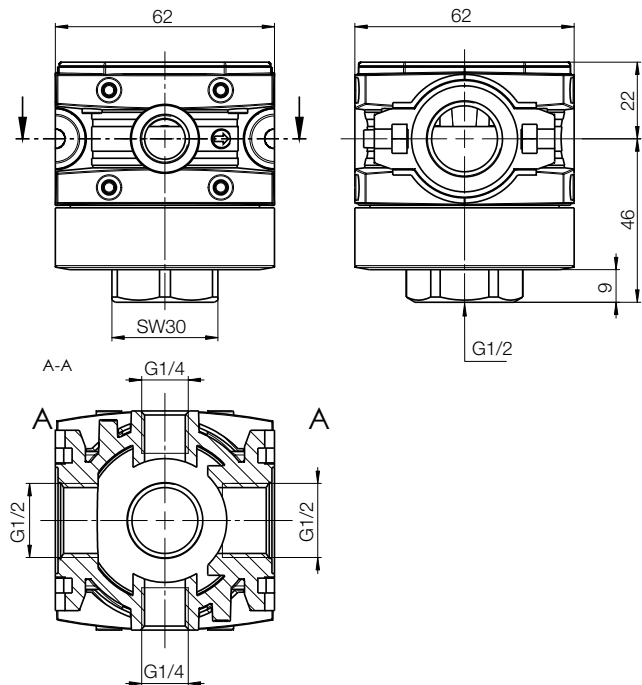

Inlet port	Bottom	Front and Back
1/2	1/2"	1/4"
3/4	3/4"	1/4"



**Solenoid coils with Din A or Industrial B connection**

Voltage	30mm x 30mm Order code DIN A Standard	Weight (Kg)	22mm x 30mm Order code Industrial B standard	Weight (Kg)
Direct current				
12V DC	<b>P2FCA445</b>	0.105	<b>P2FCB445</b>	0.093
24V DC	<b>P2FCA449</b>	0.105	<b>P2FCB449</b>	0.093
48V DC	<b>P2FCA453*</b>	0.105	<b>P2FCB451</b>	0.093
Alternative current				
12V 50/60Hz	<b>P2FCA440</b>	0.105	<b>P2FCB440</b>	0.093
24V 50/60Hz	<b>P2FCA442</b>	0.105	<b>P2FCB442</b>	0.093
48V 50/60Hz	<b>P2FCA469#</b>	0.105		
110V 50Hz, 120V 60Hz	<b>P2FCA453</b>	0.105	<b>P2FCB453</b>	0.093
230V 50Hz, 230V 60Hz	<b>P2FCA457</b>	0.105	<b>P2FCB457</b>	0.093





\* P2FCA453 is compatible with 110 V AC and 48 V DC

# P2FCA469 is 24 V DC 6.8W or 48 V 50Hz 9.9 VA

**Solenoid coils with M12 connection**

Voltage	Order code Form A 30 x 30	Weight (Kg)	Order code Form B 22 x 30	Weight (Kg)
Direct current				
24V DC	<b>P2FC6419</b>	0.065	<b>P2FC7419</b>	0.065

**Accessories**

Description	Connection	Weight (g)	Order code	
Panel mounting nut		10	<b>P3XKA00MM</b>	
Stainless steel - Wall bracket kit		80	<b>P3XKA00MW</b>	
P3X connecting kit		10	<b>P3XKA00CB</b>	
Lubricator Oil	VG15 : ISO 3448 - 100ml	100	<b>P3XKA00PPA</b>	
Pressure gauge	0 to 10 bar 0 to 16 bar	1/4" 1/4"	<b>KG8012-00</b> <b>KG8013-00</b>	
Connector O-ring kit	Qty: 5		<b>P3XKA04CY</b>	
Regulator & Filter/Regulator - Key Lock Kit		0.05	<b>P3XKA00AS</b>	

**The Problem**

Compressed air is an essential power source that is widely used throughout industry. This safe, powerful and reliable utility can be the most important part of your production process.

However, your compressed air will contain water, dirt, wear particles and even degraded lubricating oil which all mix together to form an unwanted condensate. This condensate often acidic, rapidly wears tools and pneumatic machinery, blocks valves and orifices causing high maintenance and costly air leaks. It also corrodes piping systems and can bring your production process to an extremely expensive standstill.

The use of high efficiency compressed air filters fitted with condensate drains will remove the oil, water and dirt particles to eliminate the abrasive sludge in the compressed air system.

In many cases this action alone is not enough, as modern production systems and processes demand an even higher level of air quality. Where required “point of use” membrane air dryers can provide the correct air quality, without the need for drying the complete compressed air installation, which can be both costly and totally unnecessary.

**The Efficient Solution**

The Parker P3X Series membrane air dryers employ an advanced molecular membrane technology that dries the compressed air and lowers the pressure dewpoint (PDP). The compact space saving design offer the user uncompromised performance from a dedicated “point-of-use” air dryer. It is easy to install and will transform an ordinary process into a highly reliable and efficient production operation.

The membrane material is formed into bundles of individual fibres retained in a cartridge. Water vapour escapes through the walls of the fibre to a sweep chamber from where it is continuously vented to atmosphere as a gas. A fraction of the dried air is routed through the sweep chamber to continuously purge and exhaust moisture vapour.

The P3X series membrane dryers can be used for many years to dry air continuously. They instantly respond to any change in inlet conditions. The P3X dryers perform at temperatures between 2° and 60° C (ambient or inlet) and handle pressure from 5 bar to 16 bar. The inlet flow rate and pressure determine the outlet dew point suppression. In other words, membrane dryers deliver a constant level of drying protection that follow the rise or fall of the inlet dew point temperature.

Prefilters mounted immediately upstream of the membrane dryer keep out liquids and solids to allow an almost unlimited service life. Because water vapour passes right through the membrane material, it does not accumulate there, so membranes do not become saturated and never need to be regenerated. The P3X membrane dryers have no moving parts to wear out, they are non-electric and are suitable for hazardous application areas. They require no RF shielding or protection, they do not use refrigerant gas or potentially dusty desiccants.

The P3X membrane dryer is based upon well proven principles which offer a simple cost effect alternative to refrigeration and desiccant dryers.

Available in 6 sizes, the membrane dryer is compatible with the modular P3X air preparation series which can easily be connected to the P3X filters providing a clean dry air system at the point-of-use.

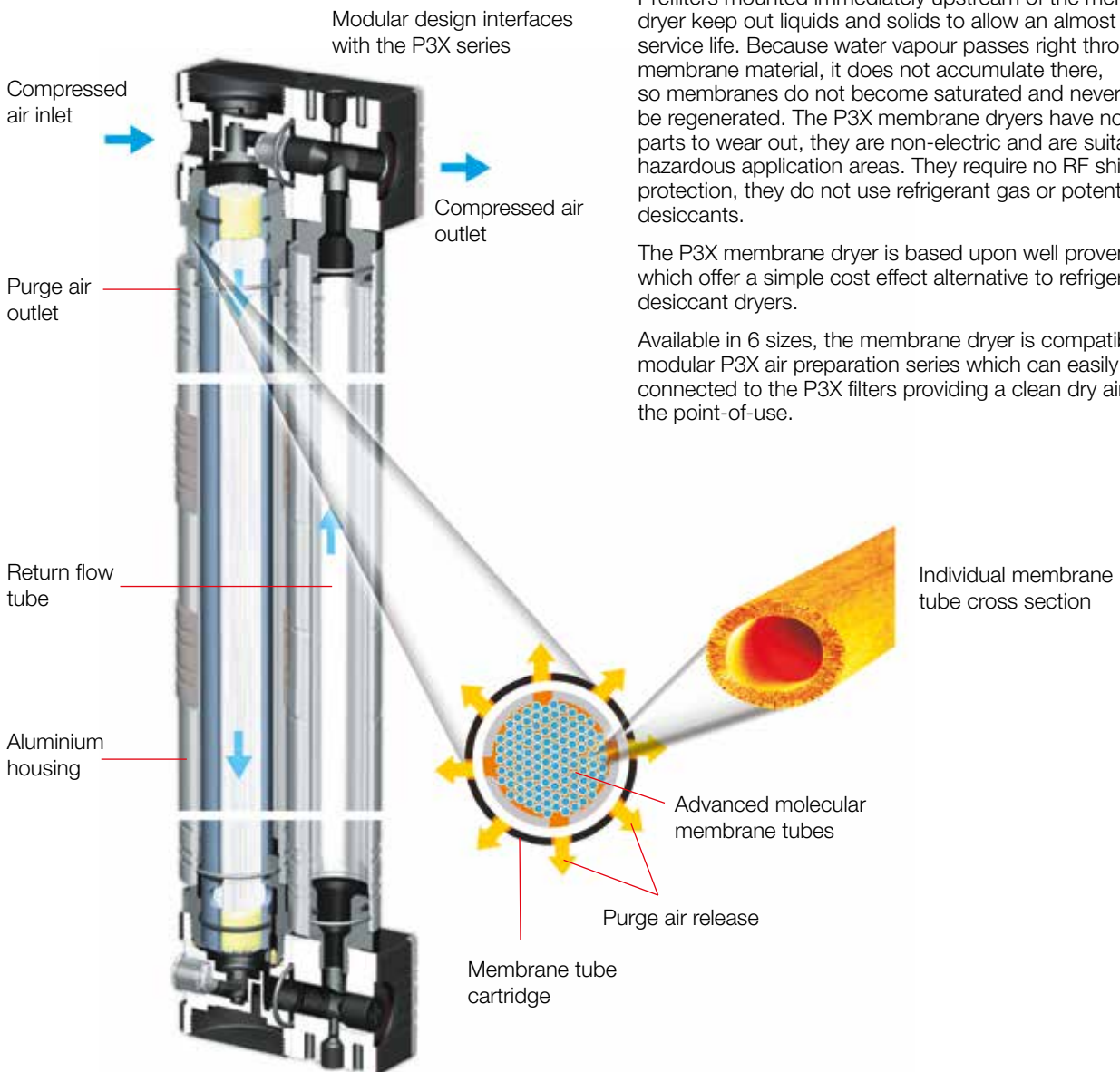

**Advantages of the P3X Series Membrane Dryers**

Dried compressed air is immediate



No electrical connection necessary

Suitable for hazardous areas



No CFC's/FC's

Compatible with the P3X series modular air preparation series



Low pressure drop

No moving parts

No drying medium required

Low purge air usage

Low operating costs



**Dryer types with PDP reduction & flow values**

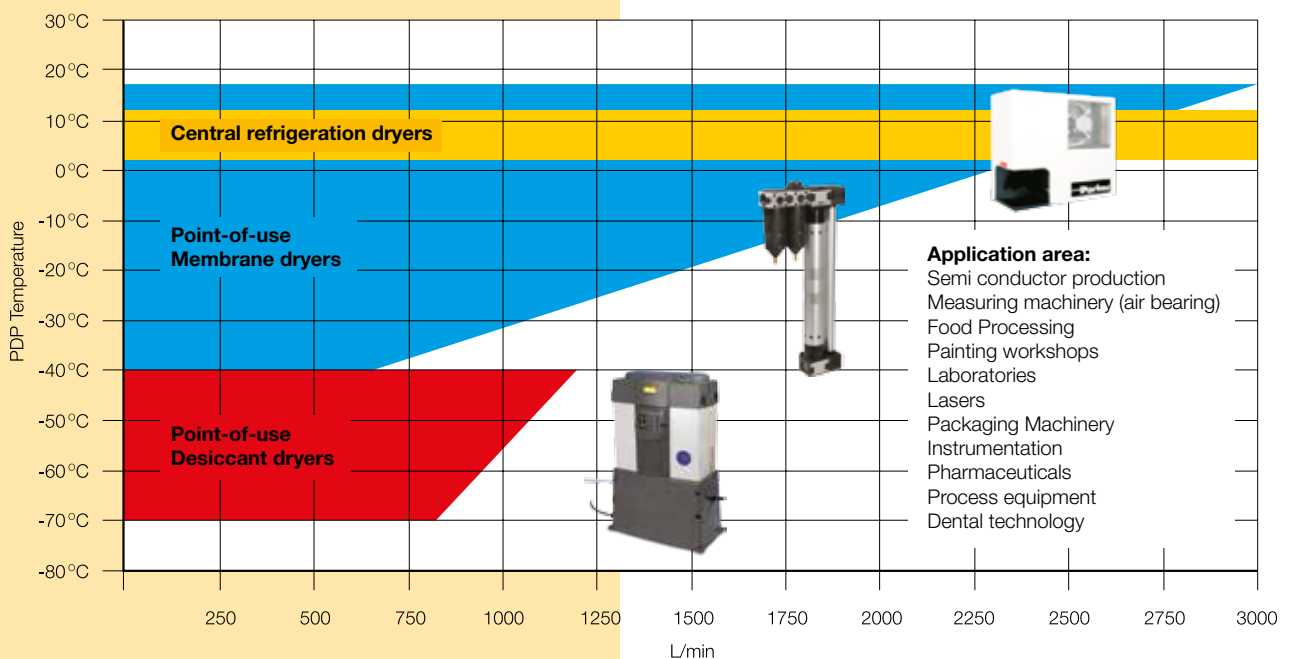

- Removes water vapour & lowers the PDP
- Compact design
- No electrical connections necessary
- Suitable for hazardous environments
- No moving parts
- Maintenance & wear free
- No change in air consumption
- Low pressure drop less than 0.1 bar
- Minimal purge air consumption
- Modular design - compatible with the P3X air prep series



**Membrane dryer**

Port size	Size	Description	Order Code
G1/2	10	Membrane dryer with return tube	<b>P3XJA14CA1N</b>
G1/2	15	Membrane dryer with return tube	<b>P3XJA14CB1N</b>
G1/2	20	Membrane dryer with return tube	<b>P3XJA14CC1N</b>
G1/2	25	Membrane dryer with return tube	<b>P3XJA14CD1N</b>
G1/2	35	Membrane dryer serial type	<b>P3XJA14CE1N</b>
G1/2	50	Membrane dryer serial type	<b>P3XJA14CF1N</b>



**Note:** For NPT threaded connections replace the 6th digit from **1** to **9** i.e. P3XJA**9**4CA1N

**Wall mounting bracket kit**

Order Code	Description
<b>P3XKA00MWD</b>	Top & bottom wall mounting bracket

**Note:**

For optimum system performance and maintenance free conditions, Parker recommend the dryer is preceded with a 5 micron and 0.01 coalescer filter from the P3X series.

**Complete Filter / Dryer System combinations available on request**



**F + Fc + MD**



**F + Fc + MD + R**



**F + Fc + MD + R + Fa**





# Parker Worldwide

## Europe, Middle East, Africa

**AE – United Arab Emirates,**  
Dubai

Tel: +971 4 8127100  
parker.me@parker.com

**AT – Austria,** Wiener Neustadt

Tel: +43 (0)2622 23501-0  
parker.austria@parker.com

**AT – Eastern Europe,** Wiener  
Neustadt

Tel: +43 (0)2622 23501 900  
parker.easteurope@parker.com

**AZ – Azerbaijan,** Baku

Tel: +994 50 2233 458  
parker.azerbaijan@parker.com

**BE/LU – Belgium,** Nivelles

Tel: +32 (0)67 280 900  
parker.belgium@parker.com

**BG – Bulgaria,** Sofia

Tel: +359 2 980 1344  
parker.bulgaria@parker.com

**BY – Belarus,** Minsk

Tel: +375 17 209 9399  
parker.belarus@parker.com

**CH – Switzerland,** Etoy

Tel: +41 (0)21 821 87 00  
parker.switzerland@parker.com

**CZ – Czech Republic,** Klecany

Tel: +420 284 083 111  
parker.czechrepublic@parker.com

**DE – Germany,** Kaarst

Tel: +49 (0)2131 4016 0  
parker.germany@parker.com

**DK – Denmark,** Ballerup

Tel: +45 43 56 04 00  
parker.denmark@parker.com

**ES – Spain,** Madrid

Tel: +34 902 330 001  
parker.spain@parker.com

**FI – Finland,** Vantaa

Tel: +358 (0)20 753 2500  
parker.finland@parker.com

**FR – France,** Contamine s/Arve

Tel: +33 (0)4 50 25 80 25  
parker.france@parker.com

**GR – Greece,** Athens

Tel: +30 210 933 6450  
parker.greece@parker.com

**HU – Hungary,** Budaörs

Tel: +36 23 885 470  
parker.hungary@parker.com

**IE – Ireland,** Dublin

Tel: +353 (0)1 466 6370  
parker.ireland@parker.com

**IT – Italy,** Corsico (MI)

Tel: +39 02 45 19 21  
parker.italy@parker.com

**KZ – Kazakhstan,** Almaty

Tel: +7 7273 561 000  
parker.easteurope@parker.com

**NL – The Netherlands,** Oldenzaal

Tel: +31 (0)541 585 000  
parker.nl@parker.com

**NO – Norway,** Asker

Tel: +47 66 75 34 00  
parker.norway@parker.com

**PL – Poland,** Warsaw

Tel: +48 (0)22 573 24 00  
parker.poland@parker.com

**PT – Portugal,** Leca da Palmeira

Tel: +351 22 999 7360  
parker.portugal@parker.com

**RO – Romania,** Bucharest

Tel: +40 21 252 1382  
parker.romania@parker.com

**RU – Russia,** Moscow

Tel: +7 495 645-2156  
parker.russia@parker.com

**SE – Sweden,** Spånga

Tel: +46 (0)8 59 79 50 00  
parker.sweden@parker.com

**SL – Slovenia,** Novo Mesto

Tel: +386 7 337 6650  
parker.slovenia@parker.com

**TR – Turkey,** Istanbul

Tel: +90 216 4997081  
parker.turkey@parker.com

**UA – Ukraine,** Kiev

Tel: +380 44 494 2731  
parker.poland@parker.com

**UK – United Kingdom,** Warwick

Tel: +44 (0)1926 317 878  
parker.uk@parker.com

**ZA – South Africa,** Kempton Park

Tel: +27 (0)11 961 0700  
parker.southafrica@parker.com

## North America

**CA – Canada,** Milton, Ontario

Tel: +1 905 693 3000

**US – USA,** Cleveland

Tel: +1 216 896 3000

## Asia Pacific

**AU – Australia,** Castle Hill

Tel: +61 (0)2-9634 7777

**CN – China,** Shanghai

Tel: +86 21 2899 5000

**HK – Hong Kong**

Tel: +852 2428 8008

**IN – India,** Mumbai

Tel: +91 22 6513 7081-85

**JP – Japan,** Tokyo

Tel: +81 (0)3 6408 3901

**KR – South Korea,** Seoul

Tel: +82 2 559 0400

**MY – Malaysia,** Shah Alam

Tel: +60 3 7849 0800

**NZ – New Zealand,** Mt Wellington

Tel: +64 9 574 1744

**SG – Singapore**

Tel: +65 6887 6300

**TH – Thailand,** Bangkok

Tel: +662 186 7000

**TW – Taiwan,** Taipei

Tel: +886 2 2298 8987

## South America

**AR – Argentina,** Buenos Aires

Tel: +54 3327 44 4129

**BR – Brazil,** Sao Jose dos Campos

Tel: +55 12 4009 3500

**CL – Chile,** Santiago

Tel: +562 2303 9640

**MX – Mexico,** Toluca

Tel: +52 72 2275 4200

European Product Information Centre

Free phone: 00 800 27 27 5374

(from AT, BE, CH, CZ, DE, DK, EE, ES, FI,  
FR, IE, IL, IS, IT, LU, MT, NL, NO, PL, PT, RU,  
SE, SK, UK, ZA)



### Parker Hannifin Ltd.

Tachbrook Park Drive

Tachbrook Park,

Warwick, CV34 6TU

United Kingdom

Tel.: +44 (0) 1926 317 878

Fax: +44 (0) 1926 317 855

parker.uk@parker.com

www.parker.com