

### ● ISO Class 4\*1 (ISO 14644-1)

- Built-in vacuum piping
- It is possible to mount the main body without removing the external cover, etc.
- Body-integrated linear guide specification

\*1 Changes depending on the suction flow rate

### Slider Type

#### Ball Screw Drive/11-LEFS Series

Step Motor (Servo/24 VDC)

Servo Motor (24 VDC)

p. 635

AC Servo Motor

p. 644, 646



Vacuum port

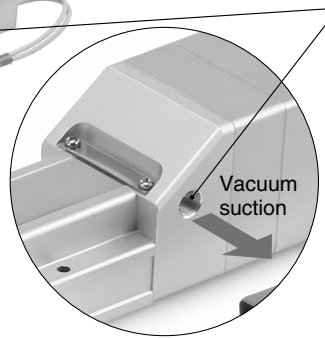

Vacuum suction

Vacuum suction from the vacuum port minimizes external particle generation from the ball screw and guide.

### High Rigidity Slider Type

#### Ball Screw Drive/11-LEJS Series

AC Servo Motor

p. 657, 659



Vacuum port

\* Port locations can be selected.

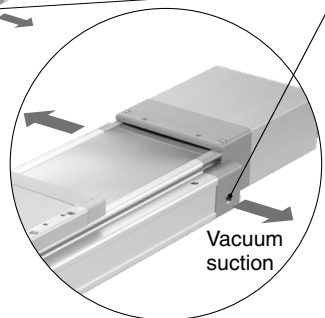

Vacuum suction

Vacuum suction from the vacuum port minimizes external particle generation from the ball screw and guide.

### Support Guide/11-LEFG Series p. 651

The support guide was designed to support workpieces with significant overhang.

- As the dimensions are the same as the LEF series body, installation is simple and contributes to a reduction in installation and assembly labor.
- The standard-equipped seal bands prevent grease from splashing and external foreign matter from entering.

### ⚠ Caution

After installing the actuator on the drive side, align it with the support guide.

If the mounting flatness exceeds 0.1, install a floating mechanism separately on the workpiece installation surface (table).

Application example

LEF (Drive side)

Support guide

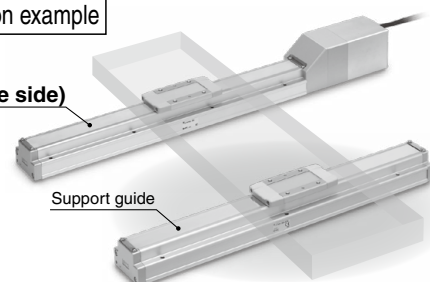

# Particle Generation Characteristics

11-LEFS Series ▶ p. 635, 644, 646

## Particle Generation Measuring Method

The particle generation data for SMC Clean Series are measured in the following test method.

### Test Method (Example)

Operate the specimen that is placed in an ISO Class 5 equivalent clean bench, and measure the changes of the particle concentration over time until the number of cycles reaches the specified point.

### Measuring Conditions

Measuring instrument	Description	Laser dust monitor (Automatic particle counter using the light scattering method)
	Minimum measurable particle diameter	0.1 μm
	Suction flow rate	28.3 L/min (ANR)
Setting conditions	Sampling time	5 min
	Interval time	55 min
	Sampling air flow	141.5 L (ANR)

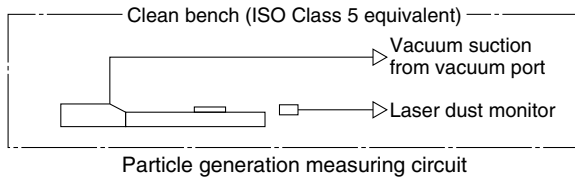

### Evaluation Method

To obtain the measured values of particle concentration, the accumulated value\*1 of particles captured every 5 minutes, by the laser dust monitor, is converted into the particle concentration in every 1 m<sup>3</sup>.

When determining particle generation grades, the 95% upper confidence limit of the average particle concentration (average value), when each specimen is operated at a specified number of cycles\*2 is considered.

The plots in the graphs indicate the 95% upper confidence limit of the average particle concentration of particles with a diameter within the horizontal axis range.

\*1 Sampling air flow rate: Number of particles contained in 141.5 L (ANR) of air

\*2 Actuator: 1 million cycles

\* The particle generation characteristics (pages 633 and 634) provide a guide for selection but is not guaranteed.

\* When the suction flow rate is 0 L/min, the particle concentration is measured during operation without suction.

LEFS  
LEFB

LEJS  
LEJB

LEL

LEM

LEY  
LEYG

LES  
LESH

LEPY  
LEPS

LER

LEH

LEY-X5

11-LEFS

11-LEJS

25A-

LEC

JXC

LECS  
LECS-T

LECY

Motorless

LAT3

# 11-LEFS Series

Step Motor (Servo/24 VDC) Servo Motor (24 VDC) Clean Room Specification

## Particle Generation Characteristics Step Motor (Servo/24 VDC), Servo Motor (24 VDC)

11-LEFS16 Speed 500 mm/s

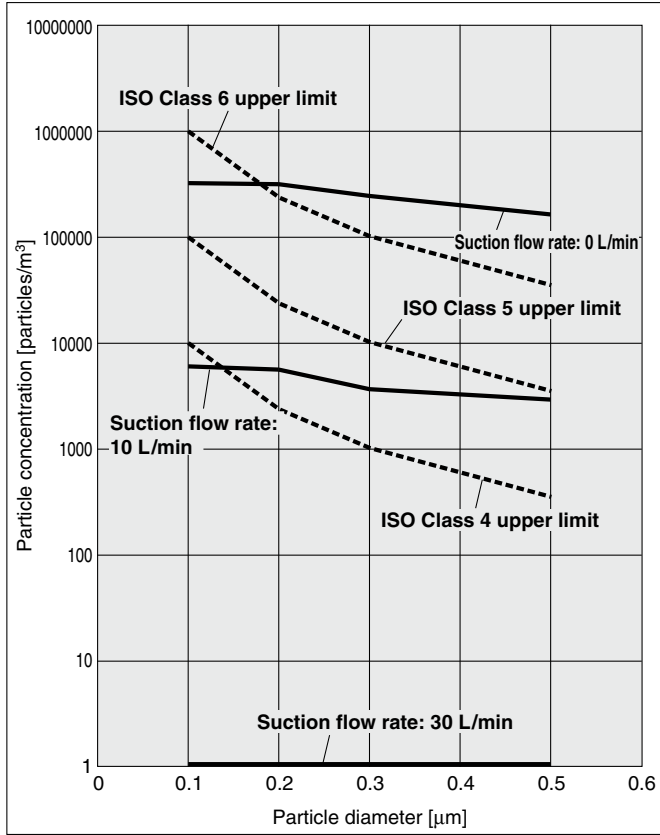

11-LEFS25 Speed 500 mm/s

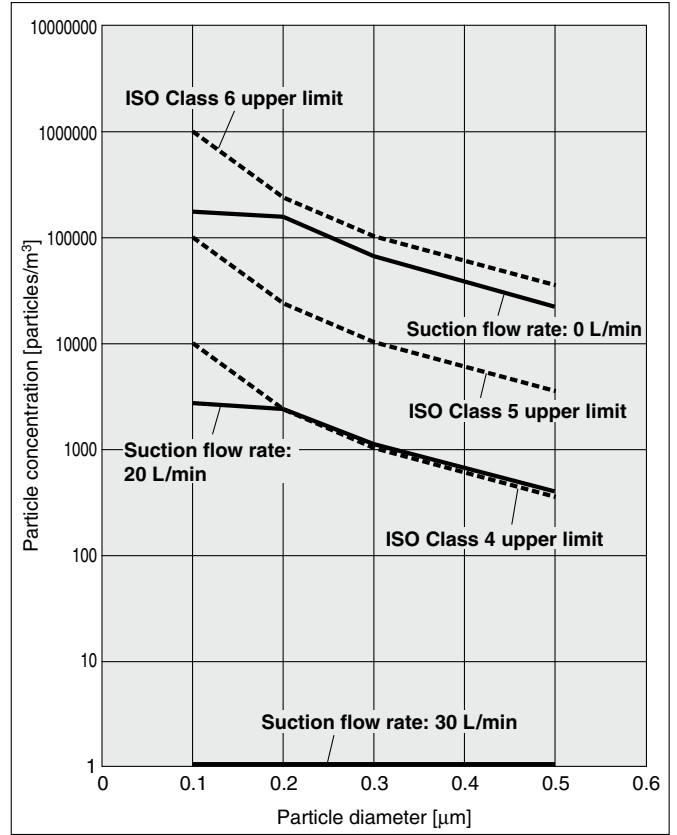

11-LEFS32 Speed 500 mm/s

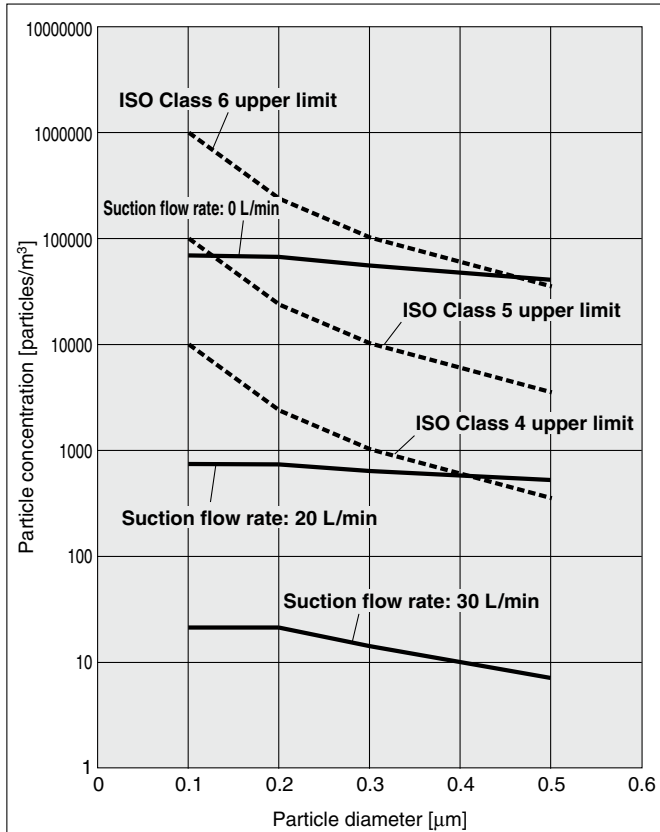

11-LEFS40 Speed 500 mm/s

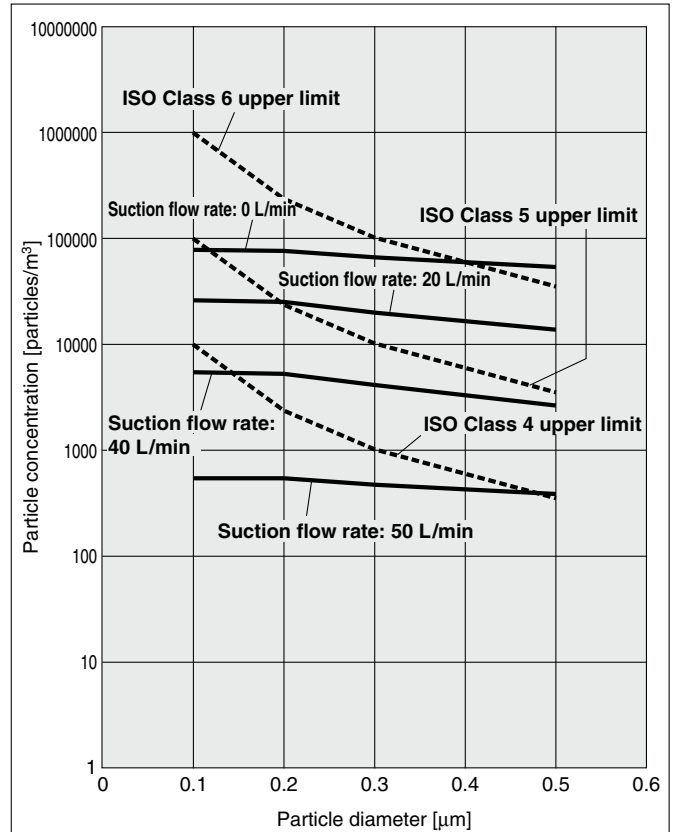

**Particle Generation Characteristics  
AC Servo Motor (100/200/400 W)**

**11-LEFS25 Speed 900 mm/s**

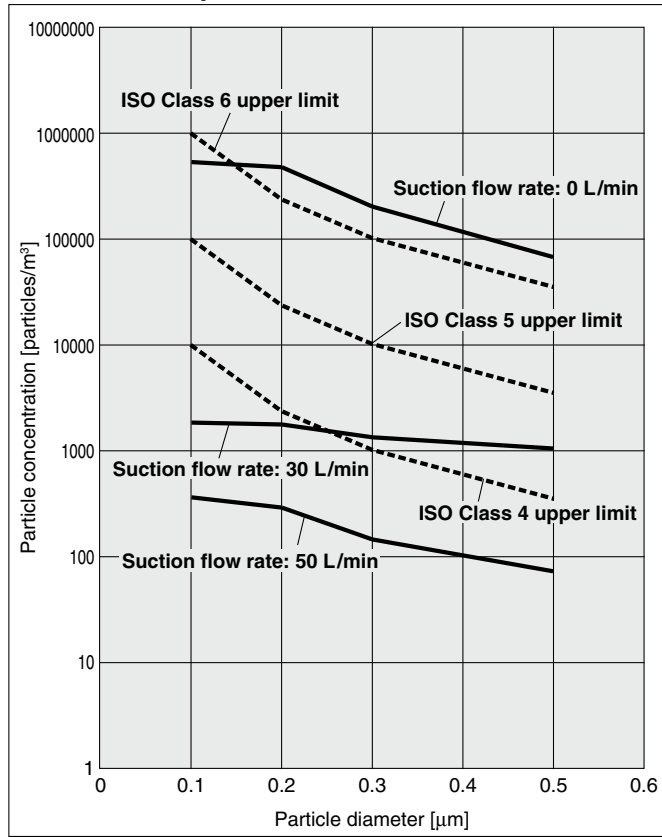

**11-LEFS32 Speed 1000 mm/s**

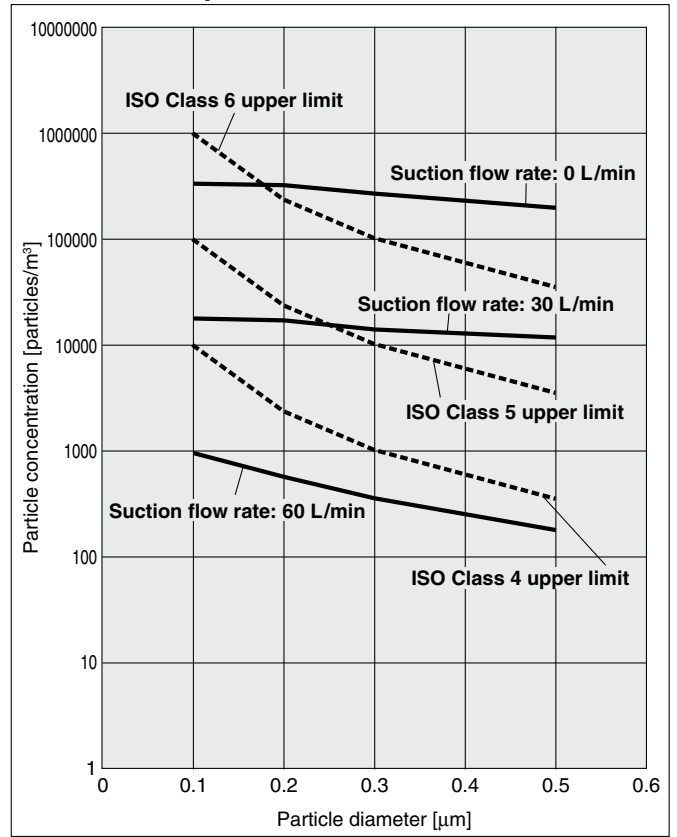

**11-LEFS40 Speed 1000 mm/s**

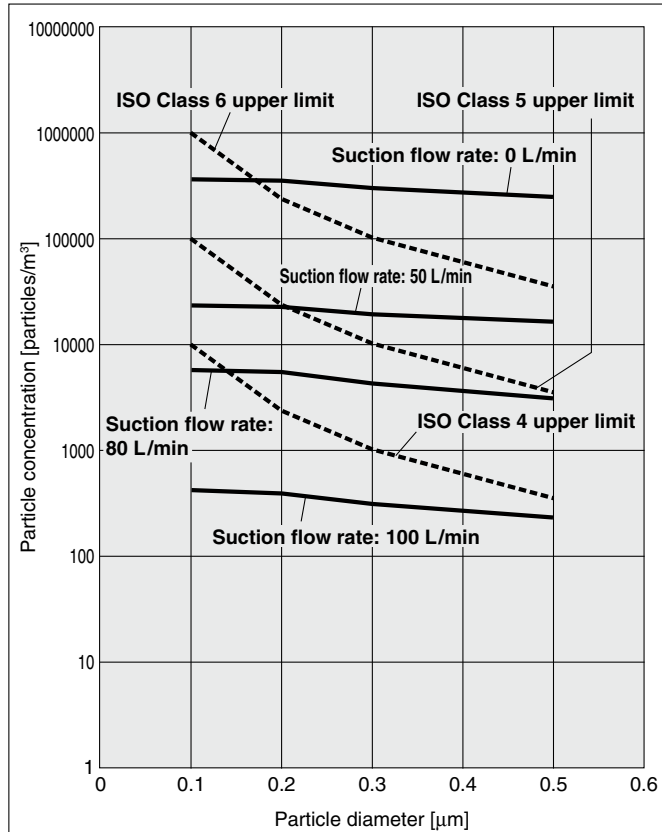

- LEFS
- LEJBS
- LEJLB
- LEL
- LEM
- LEYS
- LEYG
- LES
- LESH
- LEPY
- LEPS
- LER
- LEH
- LEH-X5
- LEY-X5
- 11-LEFS
- 11-LEJS
- 25A-
- LEC
- JXC
- LECS
- LECS-T
- LECY
- Motorless
- LAT3

# Electric Actuator/Slider Type Ball Screw Drive

Clean Room Specification



## 11-LEFS Series LEFS16, 25, 32, 40



Refer to page 31 for model selection and page 632 for particle generation characteristics.

### How to Order

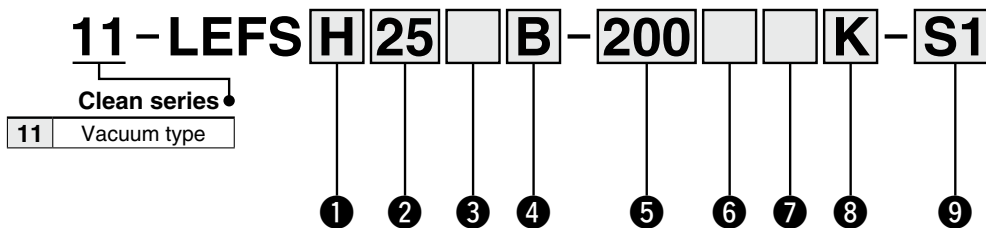
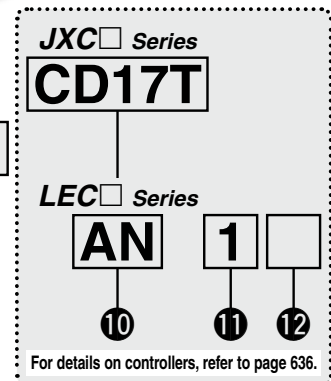

**1 Accuracy**

Nil	Basic type
H	High-precision type

**2 Size**

16
25
32
40

**3 Motor type**

Symbol	Type	Applicable size				Compatible controllers/drivers
		LEFS16	LEFS25	LEFS32	LEFS40	
Nil	Step motor (Servo/24 VDC)	●	●	●	●	JXCE1 LECP1 JXC91 LECPA JXCP1 JXCD1 JXCL1 JXCM1 JXC51 JXC61
A	Servo motor (24 VDC)	●	●	—	—	LECA6

**4 Lead [mm]**

Symbol	11-LEFS16	11-LEFS25	11-LEFS32	11-LEFS40
A	10	12	16	20
B	5	6	8	10

**6 Motor option**

Nil	Without option
B	With lock

**5 Stroke\*1 [mm]**

Stroke	Size	Note
		Applicable stroke
50 to 500	16	50, 100, 150, 200, 250, 300, 350, 400, 450, 500
50 to 600	25	50, 100, 150, 200, 250, 300, 350, 400, 450, 500, 550, 600
50 to 800	32	50, 100, 150, 200, 250, 300, 350, 400, 450, 500, 550, 600, 650, 700, 750, 800
150 to 1000	40	150, 200, 250, 300, 350, 400, 450, 500, 550, 600, 650, 700, 750, 800, 850, 900, 950, 1000

**7 Vacuum port**

Nil	Left
R	Right

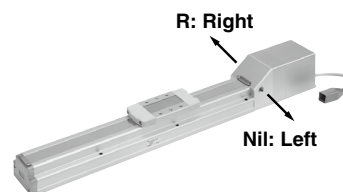

**8 Positioning pin hole**

Nil	Housing B bottom*2	
K	Body bottom 2 locations	

**9 Actuator cable type/length\*4**

Standard cable [m]		Robotic cable [m]	
Nil	None	R1	1.5
S1	1.5*6	RA	10*3
S3	3*6	R3	3
S5	5*6	RB	15*3
		R5	5
		RC	20*3
		R8	8*3

**Support Guide/11-LEFG Series**  
The support guide was designed to support workpieces with significant overhang.  
p. 651

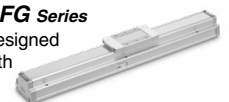

# Electric Actuator/Slider Type Ball Screw Drive **11-LEFS Series**

Step Motor (Servo/24 VDC)

Servo Motor (24 VDC)

Clean Room Specification

## JXC Series (For details, refer to page 637.)

### 10 Controller

Nil	Without controller
C□1□□	With controller

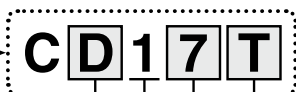

#### Interface

(Communication protocol/Input/Output)	
E	EtherCAT®
9	EtherNet/IP™
P	PROFINET
D	DeviceNet™
L	IO-Link
M	CC-Link Ver 1.10
5	Parallel input (NPN)
6	Parallel input (PNP)

#### Mounting

7	Screw mounting
8*10	DIN rail

For single axis



### Communication plug connector I/O cable\*11

Symbol	Type	Applicable interface
Nil	Without accessory	—
S	Straight type communication plug connector	DeviceNet™
T	T-branch type communication plug connector	CC-Link Ver 1.10
1	I/O cable (1.5 m)	Parallel input (NPN) Parallel input (PNP)
3	I/O cable (3 m)	
5	I/O cable (5 m)	

## LEC Series (For details, refer to page 637.)

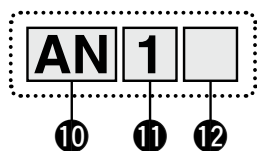

### 10 Controller/Driver type\*5

Nil		Without controller/driver	
6N	LECA6	NPN	
6P	(Step data input type)	PNP	
1N	LECP1*6	NPN	
1P	(Programless type)	PNP	
AN	LECPA*6 *7	NPN	
AP	(Pulse input type)	PNP	

### 11 I/O cable length\*8

Nil		Without cable (Without communication plug connector)	
1	1.5 m		
3	3 m*9		
5	5 m*9		

### 12 Controller/Driver mounting

Nil	Screw mounting
D	DIN rail*10



- \*1 Please consult with SMC for non-standard strokes as they are produced as special orders.
- \*2 Refer to the body mounting example on page 166 for the mounting method.
- \*3 Produced upon receipt of order (Robotic cable only)
- \*4 The standard cable should only be used on fixed parts. For use on moving parts, select the robotic cable. Refer to pages 758 and 759 if only the actuator cable is required.
- \*5 For details on controllers/drivers and compatible motors, refer to the compatible controllers/drivers on the next page.
- \*6 Only available for the motor type "Step motor"
- \*7 When pulse signals are open collector, order the current limiting resistor (LEC-PA-R-□) on page 736 separately.

- \*8 When "Without controller/driver" is selected for controller/driver types, I/O cable cannot be selected. Refer to page 713 (For LECA6), page 724 (For LECP1), or page 736 (For LECPA) if I/O cable is required.
- \*9 When "Pulse input type" is selected for controller/driver types, pulse input usable only with differential. Only 1.5 m cables usable with open collector
- \*10 The DIN rail is not included. It must be ordered separately.
- \*11 Select "Nil" for anything other than DeviceNet™, CC-Link, or parallel input. Select "Nil," "S," or "T" for DeviceNet™ or CC-Link. Select "Nil," "1," "3," or "5" for parallel input.

## ⚠ Caution

### [CE-compliant products]

- ① EMC compliance was tested by combining the electric actuator LEF series and the controller LEC/JXC series. The EMC depends on the configuration of the customer's control panel and the relationship with other electrical equipment and wiring. Therefore, compliance with the EMC directive cannot be certified for SMC components incorporated into the customer's equipment under actual operating conditions. As a result, it is necessary for the customer to verify compliance with the EMC directive for the machinery and equipment as a whole.
- ② For the servo motor (24 VDC) specification, EMC compliance was tested by installing a noise filter set (LEC-NFA). Refer to page 713 for the noise filter set. Refer to the LECA series Operation Manual for installation.

### [UL-compliant products (For the LEC series)]

When compliance with UL is required, the electric actuator and controller/driver should be used with a UL1310 Class 2 power supply.

## The actuator and controller/driver are sold as a package.

Confirm that the combination of the controller/driver and actuator is correct.

### <Check the following before use.>

- ① Check the actuator label for the model number. This number should match that of the controller/driver.
- ② Check that the Parallel I/O configuration matches (NPN or PNP).

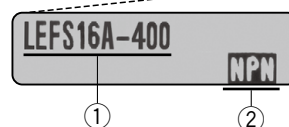

\* Refer to the Operation Manual for using the products. Please download it via our website: <https://www.smcworld.com>

LEFS  
LEFB

LEJS  
LEJB

LEL

LEM

LEY  
LEYG

LES  
LESH

LEPY  
LEPS

LER

LEH

LEY-X5

11-LEFS

11-LEJS

25A-

LEC□

JXC□

LECS□  
LECS□-T

LECY□

Motorless

LAT3







# 11-LEFS Series





Step Motor (Servo/24 VDC)

Servo Motor (24 VDC)

Clean Room Specification

## Compatible Controllers/Drivers

Type	EtherCAT® direct input type 	EtherNet/IP™ direct input type 	PROFINET direct input type 	DeviceNet™ direct input type 	IO-Link direct input type 	CC-Link direct input type 
Series	<b>JXCE1</b>	<b>JXC91</b>	<b>JXCP1</b>	<b>JXCD1</b>	<b>JXCL1</b>	<b>JXCM1</b>
Features	EtherCAT® direct input	EtherNet/IP™ direct input	PROFINET direct input	DeviceNet™ direct input	IO-Link direct input	CC-Link direct input
Compatible motor	Step motor (Servo/24 VDC)					
Max. number of step data	64 points					
Power supply voltage	24 VDC					
Reference page	741					

Type	Step data input type 	Step data input type 	Programless type 	Pulse input type 
Series	<b>JXC51</b> <b>JXC61</b>	<b>LECA6</b>	<b>LECP1</b>	<b>LECPA</b>
Features	Parallel I/O	Value (Step data) input Standard controller	Capable of setting up operation (step data) without using a PC or teaching box	Operation by pulse signals
Compatible motor	Step motor (Servo/24 VDC)	Servo motor (24 VDC)	Step motor (Servo/24 VDC)	
Max. number of step data	64 points		14 points	—
Power supply voltage	24 VDC			
Reference page	706-1	707	719	731

# Electric Actuator/Slider Type Ball Screw Drive **11-LEFS Series**

Step Motor (Servo/24 VDC)

Servo Motor (24 VDC)

Clean Room Specification

## Specifications

### Step Motor (Servo/24 VDC)

Model		11-LEFS16		11-LEFS25		11-LEFS32		11-LEFS40				
Actuator specifications	Stroke [mm]*1	50 to 500		50 to 600		50 to 800		150 to 1000				
	Work load [kg]	Horizontal	JXC□1/LECP1		14	15	25	30	45	50	55	65
			LECPA/JXC□2□3		9	10	20	20	40	45	50	60
	Speed [mm/s]*2	Vertical			2	4	7.5	15	10	20	2	23
					10 to 500	5 to 250	12 to 500	6 to 250	16 to 500	8 to 250	20 to 500	10 to 250
	Max. acceleration/deceleration [mm/s <sup>2</sup> ]		3000									
	Positioning repeatability [mm]	Basic type		±0.02								
		High-precision type		±0.015								
	Lost motion*3 [mm]	Basic type		0.1 or less								
		High-precision type		0.05 or less								
	Lead [mm]		10	5	12	6	16	8	20	10		
	Impact/Vibration resistance [m/s <sup>2</sup> ]*4		50/20									
	Actuation type		Ball screw									
	Guide type		Linear guide									
Static allowable moment*5 [N·m]	Mep (Pitching)		10		27		46		110			
	Mey (Yawing)		10		27		46		110			
	Mer (Rolling)		20		52		101		207			
Operating temperature range [°C]		5 to 40										
Operating humidity range [%RH]		90 or less (No condensation)										
Cleanliness class*6		ISO Class 4 (ISO 14644-1)										
Grease	Ball screw /Linear guide portion		Low particle generation grease									
Electric specifications	Motor size		□28		□42		□56.4					
	Motor type		Step motor (Servo/24 VDC)									
	Encoder		Incremental									
	Power supply voltage [V]		24 VDC ±10%									
Lock unit specifications	Power [W]*7 *9		Max. power 51		Max. power 57		Max. power 123		Max. power 141			
	Type*8		Non-magnetizing lock									
	Holding force [N]		20	39	78	157	108	216	113	225		
	Power consumption [W]*9		2.9		5		5		5			
Rated voltage [V]		24 VDC ±10%										

- \*1 Please consult with SMC for non-standard strokes as they are produced as special orders.
- \*2 Speed changes according to the controller/driver type and work load. Check the "Speed-Work Load Graph (Guide)" on pages 32 and 33. Furthermore, if the cable length exceeds 5 m, then it will decrease by up to 10% for each 5 m.
- \*3 A reference value for correcting an error in reciprocal operation
- \*4 Impact resistance: No malfunction occurred when the actuator was tested with a drop tester in both an axial direction and a perpendicular direction to the lead screw. (The test was performed with the actuator in the initial state.)  
Vibration resistance: No malfunction occurred in a test ranging between 45 to 2000 Hz. The test was performed in both an axial direction and a perpendicular direction to the lead screw. (The test was performed with the actuator in the initial state.)
- \*5 The static allowable moment is the amount of static moment which can be applied to the actuator when it is stopped.  
If the product is exposed to impact or repeated load, be sure to take adequate safety measures when using the product.
- \*6 The amount of particle generation changes according to the operating conditions and suction flow rate. Refer to the particle generation characteristics for details.
- \*7 Indicates the max. power during operation (including the controller)  
This value can be used for the selection of the power supply.
- \*8 With lock only
- \*9 For an actuator with lock, add the power consumption for the lock.

- LEFS
- LEFB
- LEJS
- LEJB
- LEL
- LEM
- LEY
- LEYG
- LES
- LESH
- LEPY
- LEPS
- LER
- LEH
- LEY-X5
- 11-LEFS
- 11-LEJS
- 25A-
- LEC□
- LEC
- JXC□
- JXC
- LECS□
- LECS□-T
- LECY□
- LECY
- Motorless
- LAT3



# 11-LEFS Series

Step Motor (Servo/24 VDC)

Servo Motor (24 VDC)

Clean Room Specification

## Specifications

### Servo Motor (24 VDC)

Model		11-LEFS16A		11-LEFS25A		
Actuator specifications	Stroke [mm] <sup>*1</sup>	50 to 500		50 to 600		
	Work load <sup>*2</sup> [kg]	Horizontal	7	10	11	18
		Vertical	2	4	2.5	5
	Speed [mm/s] <sup>*2</sup>	1 to 500	1 to 250	2 to 500	1 to 250	
	Max. acceleration/deceleration [mm/s <sup>2</sup> ]	3000				
	Positioning repeatability [mm]	Basic type	±0.02			
		High-precision type	±0.015			
	Lost motion <sup>*3</sup> [mm]	Basic type	0.1 or less			
		High-precision type	0.05 or less			
	Lead [mm]	10	5	12	6	
	Impact/Vibration resistance [m/s <sup>2</sup> ] <sup>*4</sup>	50/20				
	Actuation type	Ball screw				
	Guide type	Linear guide				
	Static allowable moment <sup>*5</sup> [N·m]	Mep (Pitching)	10		27	
		Mey (Yawing)	10		27	
Mer (Rolling)		20		52		
Operating temperature range [°C]	5 to 40					
Operating humidity range [%RH]	90 or less (No condensation)					
Cleanliness class <sup>*6</sup>	ISO Class 4 (ISO 14644-1)					
Grease   Ball screw/Linear guide portion	Low particle generation grease					
Electric specifications	Motor size	□28		□42		
	Motor output [W]	30		36		
	Motor type	Servo motor (24 VDC)				
	Encoder	Incremental				
	Power supply voltage [V]	24 VDC ±10%				
Lock unit specifications	Power [W] <sup>*7 *9</sup>	Max. power 70		Max. power 113		
	Type <sup>*8</sup>	Non-magnetizing lock				
	Holding force [N]	20	39	78	157	
Power consumption [W] <sup>*9</sup>	2.9		5			
Rated voltage [V]	24 VDC ±10%					

\*1 Please consult with SMC for non-standard strokes as they are produced as special orders.

\*2 Check the "Speed-Work Load Graph (Guide)" on page 35 for details. Furthermore, if the cable length exceeds 5 m, then it will decrease by up to 10% for each 5 m.

\*3 A reference value for correcting an error in reciprocal operation

\*4 Impact resistance: No malfunction occurred when the actuator was tested with a drop tester in both an axial direction and a perpendicular direction to the lead screw. (The test was performed with the actuator in the initial state.)

Vibration resistance: No malfunction occurred in a test ranging between 45 to 2000 Hz. The test was performed in both an axial direction and a perpendicular direction to the lead screw. (The test was performed with the actuator in the initial state.)

\*5 The static allowable moment is the amount of static moment which can be applied to the actuator when it is stopped.

If the product is exposed to impact or repeated load, be sure to take adequate safety measures when using the product.

\*6 The amount of particle generation changes according to the operating conditions and suction flow rate. Refer to the particle generation characteristics for details.

\*7 Indicates the max. power during operation (including the controller)

This value can be used for the selection of the power supply.

\*8 With lock only

\*9 For an actuator with lock, add the power consumption for the lock.

## Weight

Series	11-LEFS16									
Stroke [mm]	50	100	150	200	250	300	350	400	450	500
Product weight [kg]	0.83	0.90	0.98	1.05	1.13	1.20	1.28	1.35	1.43	1.50
Additional weight with lock [kg]	0.12									

Series	11-LEFS25											
Stroke [mm]	50	100	150	200	250	300	350	400	450	500	550	600
Product weight [kg]	1.70	1.84	1.98	2.12	2.26	2.40	2.54	2.68	2.82	2.96	3.10	3.24
Additional weight with lock [kg]	0.26											

Series	11-LEFS32															
Stroke [mm]	50	100	150	200	250	300	350	400	450	500	550	600	650	700	750	800
Product weight [kg]	3.15	3.35	3.55	3.75	3.95	4.15	4.35	4.55	4.75	4.95	5.15	5.35	5.55	5.75	5.95	6.15
Additional weight with lock [kg]	0.53															

Series	11-LEFS40																			
Stroke [mm]	150	200	250	300	350	400	450	500	550	600	650	700	750	800	850	900	950	1000		
Product weight [kg]	5.37	5.65	5.93	6.21	6.49	6.77	7.15	7.33	7.61	7.89	8.17	8.45	8.75	9.01	9.29	9.57	9.85	10.13		
Additional weight with lock [kg]	0.53																			

**Dimensions: Ball Screw Drive**

**11-LEFS16**

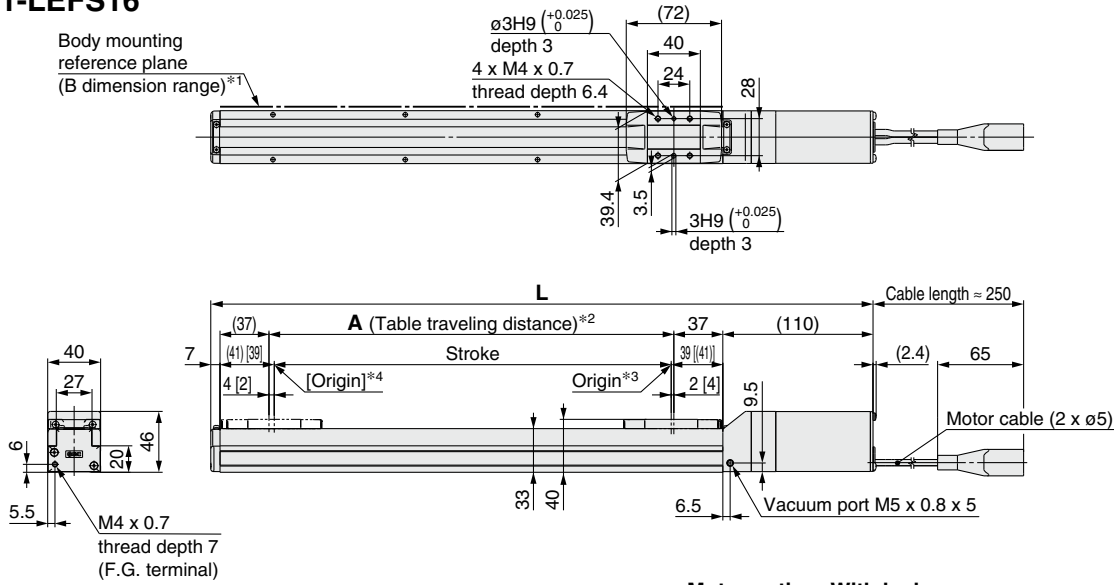

**Motor option: With lock**

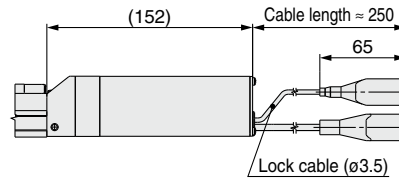

**Step motor**



**Servo motor**

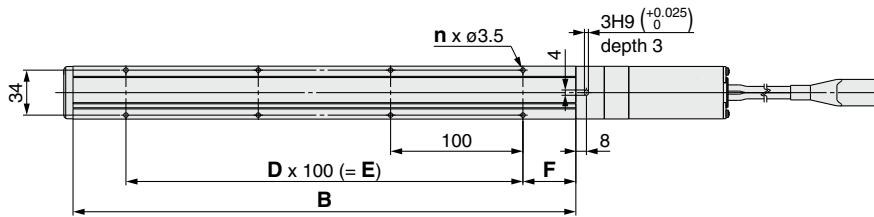
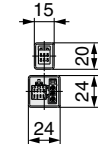

**Positioning pin hole\*5 (Option): Body bottom**

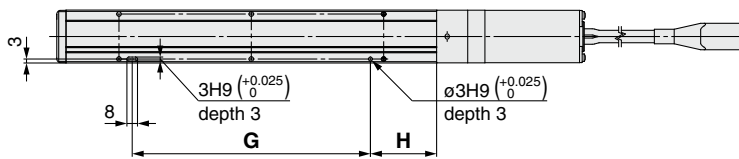

- \*1 When mounting the actuator using the body mounting reference plane, set the height of the opposite surface or pin to be 2 mm or more because of round chamfering. (Recommended height 5 mm)  
In addition, be aware that surfaces other than the body mounting reference plane (B dimension range) may slightly protrude from the body mounting reference plane. Be sure to provide a clearance of 1 mm or more to avoid interference with workpieces, facilities, etc.
- \*2 This is the distance within which the table can move when it returns to origin.  
Make sure workpieces mounted on the table do not interfere with the workpieces and facilities around the table.
- \*3 Position after returning to origin
- \*4 [ ] for when the direction of return to origin has changed
- \*5 When using the body bottom positioning pin holes, do not simultaneously use the housing B bottom pin hole.

**Dimensions**

Model	L		A	B	n	D	E	F	G	H
	Without lock	With lock								
11-LEFS16□-50□	247	289	56	130	4	—	—	40	80	25
11-LEFS16□-100□	297	339	106	180	4	—	—		80	50
11-LEFS16□-150□	347	389	156	230	4	—	—		80	50
11-LEFS16□-200□	397	439	206	280	6	2	200		180	50
11-LEFS16□-250□	447	489	256	330	6	2	200		180	50
11-LEFS16□-300□	497	539	306	380	8	3	300		280	50
11-LEFS16□-350□	547	589	356	430	8	3	300		280	50
11-LEFS16□-400□	597	639	406	480	10	4	400		380	50
11-LEFS16□-450□	647	689	456	530	10	4	400		380	50
11-LEFS16□-500□	697	739	506	580	12	5	500		480	50

- LEFS
- LEFB
- LEJS
- LEJB
- LEL
- LEM
- LEYG
- LESH
- LEPS
- LER
- LEH
- LEY-X5
- 11-LEFS
- 11-LEJS
- 25A-
- LEC□
- JXC□
- LECS□
- LECS□-T
- Motorless
- LAT3

# 11-LEFS Series

Step Motor (Servo/24 VDC)

Servo Motor (24 VDC)

Clean Room Specification

## Dimensions: Ball Screw Drive

### 11-LEFS25

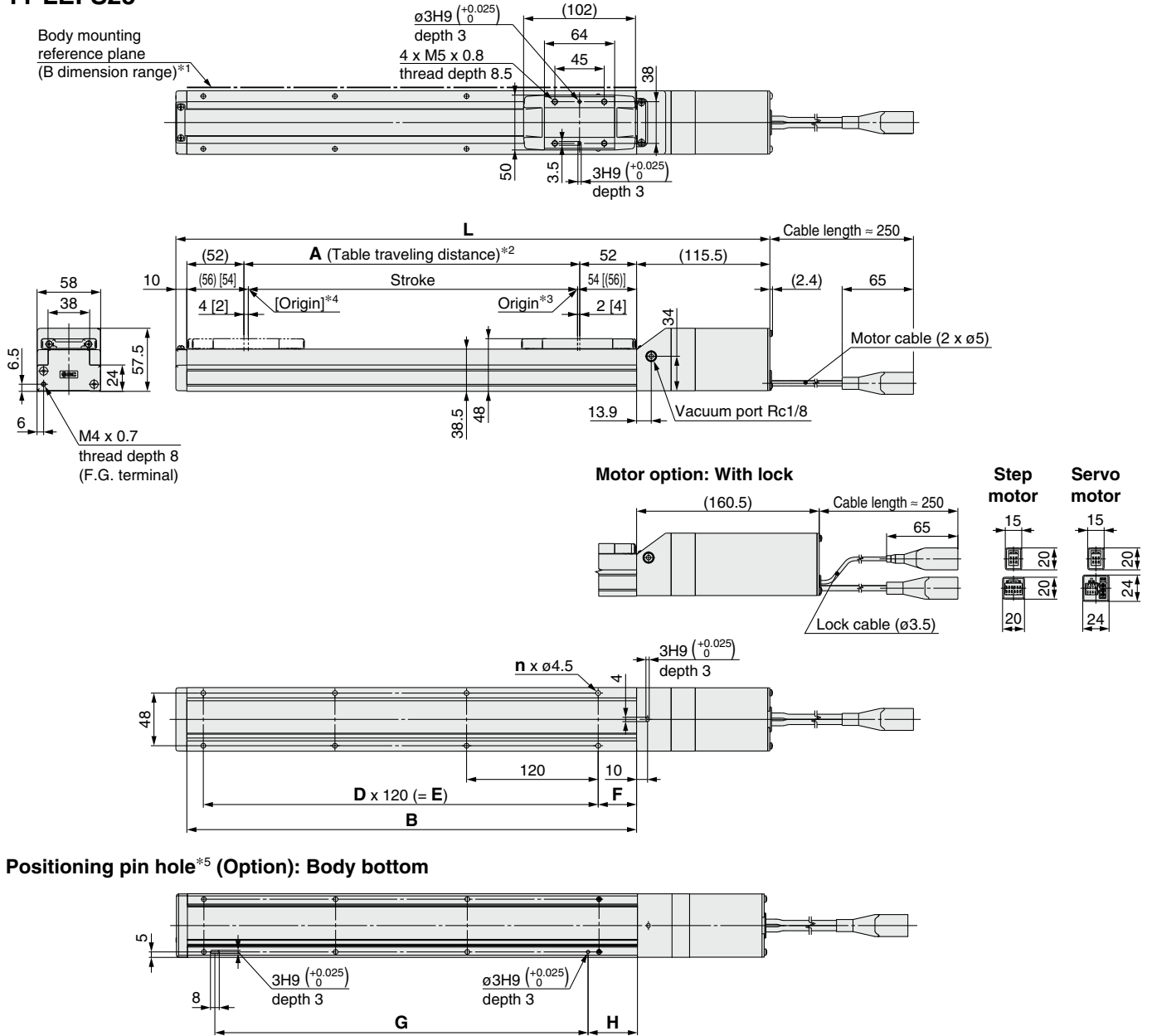

- \*1 When mounting the actuator using the body mounting reference plane, set the height of the opposite surface or pin to be 3 mm or more because of round chamfering. (Recommended height 5 mm)  
In addition, be aware that surfaces other than the body mounting reference plane (B dimension range) may slightly protrude from the body mounting reference plane. Be sure to provide a clearance of 1 mm or more to avoid interference with workpieces, facilities, etc.
- \*2 This is the distance within which the table can move when it returns to origin. Make sure workpieces mounted on the table do not interfere with the workpieces and facilities around the table.
- \*3 Position after returning to origin
- \*4 [ ] for when the direction of return to origin has changed
- \*5 When using the body bottom positioning pin holes, do not simultaneously use the housing B bottom pin hole.

### Dimensions

Model	L		A	B	n	D	E	F	G	H	
	Without lock	With lock									
11-LEFS25□-50□	285.5	330.5	56	160	4	—	—	35	20	100	30
11-LEFS25□-100□	335.5	380.5	106	210	4	—	—		100	45	
11-LEFS25□-150□	385.5	430.5	156	260	4	—	—		100	45	
11-LEFS25□-200□	435.5	480.5	206	310	6	2	240		220	45	
11-LEFS25□-250□	485.5	530.5	256	360	6	2	240		220	45	
11-LEFS25□-300□	535.5	580.5	306	410	8	3	360		340	45	
11-LEFS25□-350□	585.5	630.5	356	460	8	3	360		340	45	
11-LEFS25□-400□	635.5	680.5	406	510	8	3	360		340	45	
11-LEFS25□-450□	685.5	730.5	456	560	10	4	480		460	45	
11-LEFS25□-500□	735.5	780.5	506	610	10	4	480		460	45	
11-LEFS25□-550□	785.5	830.5	556	660	12	5	600		580	45	
11-LEFS25□-600□	835.5	880.5	606	710	12	5	600		580	45	

**Dimensions: Ball Screw Drive**

**11-LEFS32**

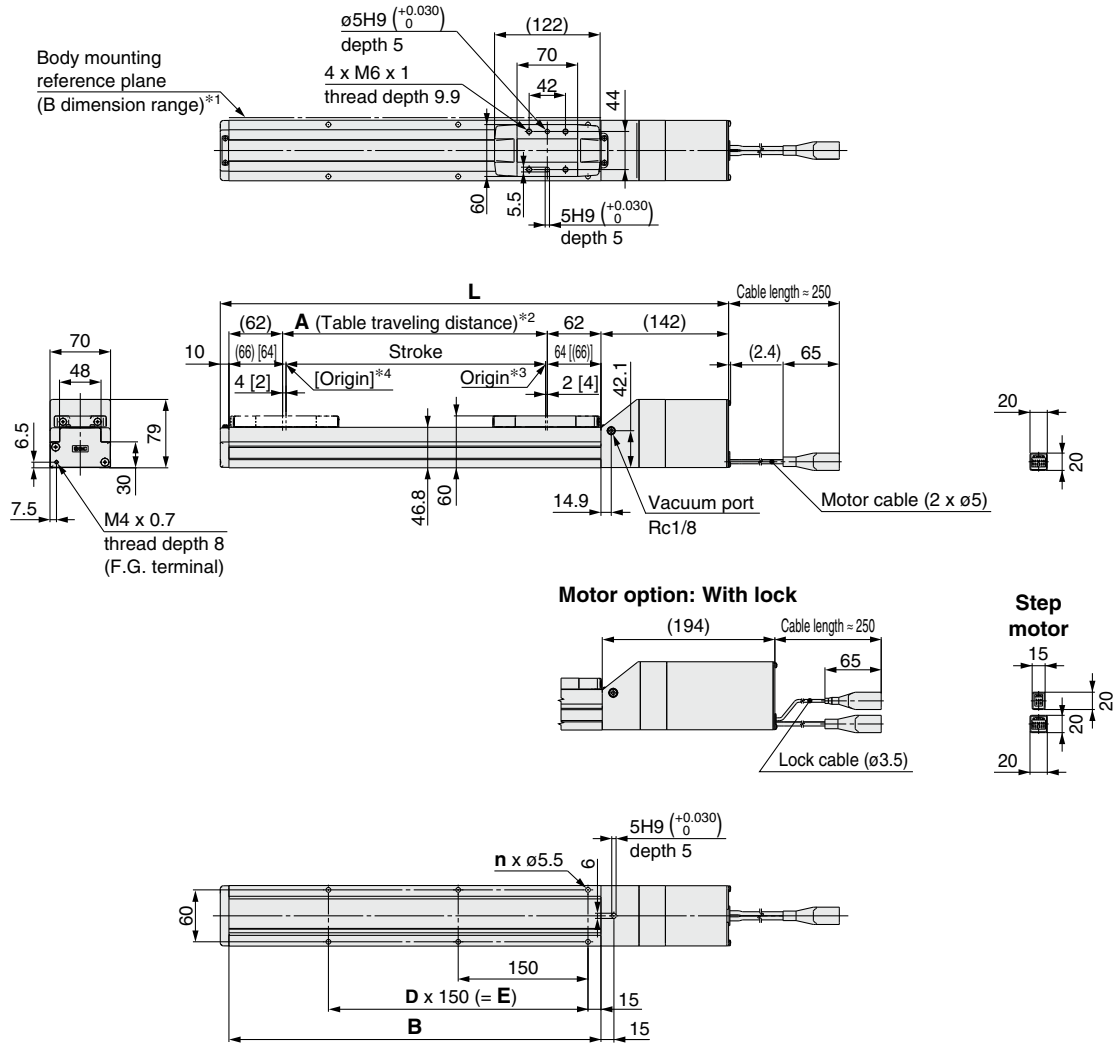

**Positioning pin hole\*5 (Option): Body bottom**

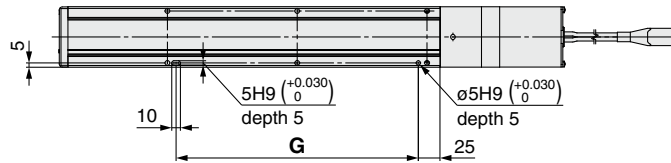

- \*1 When mounting the actuator using the body mounting reference plane, set the height of the opposite surface or pin to be 3 mm or more because of round chamfering. (Recommended height 5 mm)  
In addition, be aware that surfaces other than the body mounting reference plane (B dimension range) may slightly protrude from the body mounting reference plane. Be sure to provide a clearance of 1 mm or more to avoid interference with workpieces, facilities, etc.
- \*2 This is the distance within which the table can move when it returns to origin.  
Make sure workpieces mounted on the table do not interfere with the workpieces and facilities around the table.
- \*3 Position after returning to origin
- \*4 [ ] for when the direction of return to origin has changed
- \*5 When using the body bottom positioning pin holes, do not simultaneously use the housing B bottom pin hole.

**Dimensions**

Model	L		A	B	n	D	E	G
	Without lock	With lock						
11-LEFS32□-50□	332	384	56	180	4	—	—	130
11-LEFS32□-100□	382	434	106	230	4	—	—	130
11-LEFS32□-150□	432	484	156	280	4	—	—	130
11-LEFS32□-200□	482	534	206	330	6	2	300	280
11-LEFS32□-250□	532	584	256	380	6	2	300	280
11-LEFS32□-300□	582	634	306	430	6	2	300	280
11-LEFS32□-350□	632	684	356	480	8	3	450	430
11-LEFS32□-400□	682	734	406	530	8	3	450	430
11-LEFS32□-450□	732	784	456	580	8	3	450	430
11-LEFS32□-500□	782	834	506	630	10	4	600	580
11-LEFS32□-550□	832	884	556	680	10	4	600	580
11-LEFS32□-600□	882	934	606	730	10	4	600	580
11-LEFS32□-650□	932	984	656	780	12	5	750	730
11-LEFS32□-700□	982	1034	706	830	12	5	750	730
11-LEFS32□-750□	1032	1084	756	880	12	5	750	730
11-LEFS32□-800□	1082	1134	806	930	14	6	900	880

- LEFS
- LEFB
- LEJS
- LEJB
- LEL
- LEM
- LEJ
- LEY
- LEYG
- LES
- LESH
- LEPY
- LEPS
- LER
- LEH
- LEY-X5
- 11-LEFS
- 11-LEJS
- 25A-
- LEC□
- JXC□
- LECS□
- LECS□-T
- LECY□
- Motorless
- LAT3

# 11-LEFS Series

Step Motor (Servo/24 VDC)

Servo Motor (24 VDC)

Clean Room Specification

## Dimensions: Ball Screw Drive

### 11-LEFS40

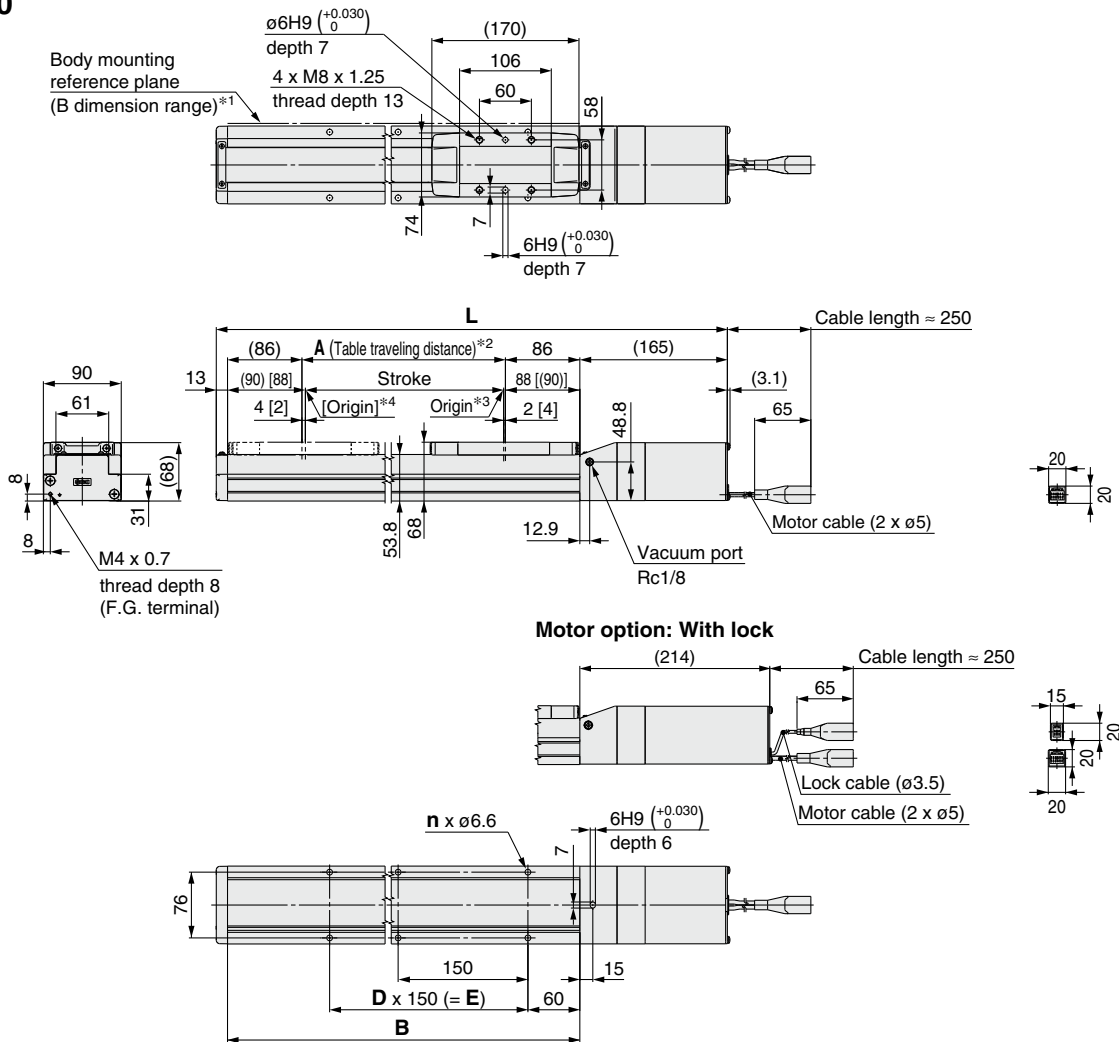

### Positioning pin hole\*5 (Option): Body bottom

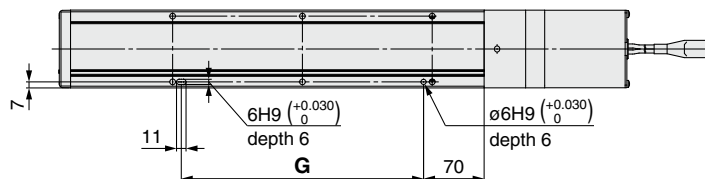

\*1 When mounting the actuator using the body mounting reference plane, set the height of the opposite surface or pin to be 3 mm or more because of round chamfering. (Recommended height 5 mm) In addition, be aware that surfaces other than the body mounting reference plane (B dimension range) may slightly protrude from the body mounting reference plane. Be sure to provide a clearance of 1 mm or more to avoid interference with workpieces, facilities, etc.

\*2 This is the distance within which the table can move when it returns to origin. Make sure workpieces mounted on the table do not interfere with the workpieces and facilities around the table.

\*3 Position after returning to origin

\*4 [ ] for when the direction of return to origin has changed

\*5 When using the body bottom positioning pin holes, do not simultaneously use the housing B bottom pin hole.

### Dimensions

[mm]

Model	L		A	B	n	D	E	G
	Without lock	With lock						
11-LEFS40□-150□	506	555	156	328	4	—	150	130
11-LEFS40□-200□	556	605	206	378	6	2	300	280
11-LEFS40□-250□	606	655	256	428	6	2	300	280
11-LEFS40□-300□	656	705	306	478	6	2	300	280
11-LEFS40□-350□	706	755	356	528	8	3	450	430
11-LEFS40□-400□	756	805	406	578	8	3	450	430
11-LEFS40□-450□	806	855	456	628	8	3	450	430
11-LEFS40□-500□	856	905	506	678	10	4	600	580
11-LEFS40□-550□	906	955	556	728	10	4	600	580
11-LEFS40□-600□	956	1005	606	778	10	4	600	580
11-LEFS40□-650□	1006	1055	656	828	12	5	750	730
11-LEFS40□-700□	1056	1105	706	878	12	5	750	730
11-LEFS40□-750□	1106	1155	756	928	12	5	750	730
11-LEFS40□-800□	1156	1205	806	978	14	6	900	880
11-LEFS40□-850□	1206	1255	856	1028	14	6	900	880
11-LEFS40□-900□	1256	1305	906	1078	14	6	900	880
11-LEFS40□-950□	1306	1355	956	1128	16	7	1050	1030
11-LEFS40□-1000□	1356	1405	1006	1178	16	7	1050	1030

# Electric Actuator/Slider Type Ball Screw Drive Clean Room Specification

## 11-LEFS Series LEFS25, 32, 40

The LECSB-S, LECS-S, and LECS-S electric actuator drivers are to be discontinued. The LECSB-T, LECS-T, and LECS-T drivers are available as substitutes. In the product number, select T6 instead of S6, T7 instead of S7, or T8 instead of S8 for the **Motor type**, and select B2 instead of B1, C2 instead of C1, or S2 instead of S1 for the **Driver type**.

Refer to page 39 for model selection and page 632 for particle generation characteristics.



LECY Series ▶ p. 646

### How to Order

Click here for details. Click here for details.

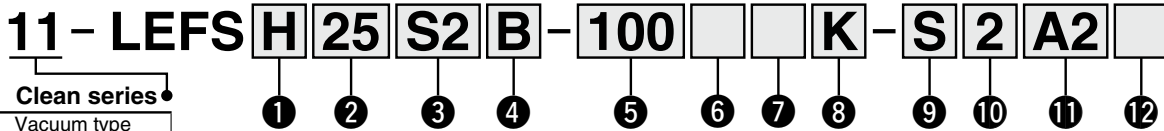

**Clean series**  
11 Vacuum type

#### ① Accuracy

Nil	Basic type
H	High-precision type

#### ② Size

25
32
40

#### ④ Lead [mm]

Symbol	11-LEFS25	11-LEFS32	11-LEFS40
A	12	16	20
B	6	8	10

#### ⑤ Stroke [mm]

50	50
to	to
1000	1000

#### ⑥ Motor option

Nil	Without option
B	With lock

#### ③ Motor type

Symbol	Type	Output [W]	Actuator size	Compatible drivers	UL-compliant
S2*1	AC servo motor (Incremental encoder)	100	25	LECSA□-S1	●
S3		200	32	LECSA□-S3	●
S4		400	40	LECSA2-S4	●
S6*1	AC servo motor (Absolute encoder)	100	25	LECSB□-S5 LECS□-S5 LECSS□-S5	—
S7		200	32	LECSB□-S7 LECS□-S7 LECSS□-S7	—
S8		400	40	LECSB2-S8 LECS□2-S8 LECSS2-S8	—
T6*2	AC servo motor (Absolute encoder)	100	25	LECSB2-T5 LECS□2-T5 LECSN2-T5□ LECSS2-T5	●
T7		200	32	LECSB2-T7 LECS□2-T7 LECSN2-T7□ LECSS2-T7	●
T8		400	40	LECSB2-T8 LECS□2-T8 LECSN2-T8□ LECSS2-T8	●

\*1 For motor type S2 and S6, the compatible driver part number suffixes are S1 and S5 respectively.

\*2 For motor type T6, the compatible driver part number is LECS□2-T5.

#### ⑫ I/O cable length [m]\*1

Nil	Without cable
H	Without cable (Connector only)
1	1.5

\*1 When "Without driver" is selected for driver type, only "Nil: Without cable" can be selected. Refer to page 797 if I/O cable is required. (Options are shown on page 797.)

#### ⑧ Positioning pin hole

Nil	Housing B bottom*1	
K	Body bottom 2 locations	

\*1 Refer to the body mounting example on page 166 for the mounting method.

#### ⑨ Cable type\*1 \*2

Nil	Without cable
S	Standard cable
R	Robotic cable (Flexible cable)

\*1 The motor and encoder cables are included. (The lock cable is also included when the motor with lock option is selected.)

\*2 Standard cable entry direction is "(B) Counter axis side." (Refer to page 796 for details.)

#### ⑩ Cable length\*1

Nil	Without cable
2	2 m
5	5 m
A	10 m

\*1 The length of the encoder, motor, and lock cables are the same.

#### ⑦ Vacuum port\*1

Nil	Left
R	Right
D	Both left and right

\*1 Select "D" for the vacuum port for suction of 50 L/min (ANR) or more.

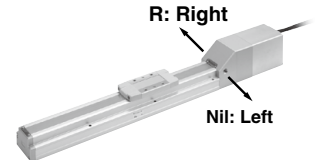

#### ⑪ Driver type

	Compatible drivers	Power supply voltage [V]	Size		
			25	32	40
Nil	Without driver	—	●	●	●
A1	LECSA1-S□	100 to 120	●	●	—
A2	LECSA2-S□	200 to 230	●	●	●
B1	LECSB1-S□	100 to 120	●	●	—
B2	LECSB2-S□	200 to 230	●	●	●
	LECSB2-T□	200 to 240	●	●	●
C1	LECS□1-S□	100 to 120	●	●	—
C2	LECS□2-S□	200 to 230	●	●	●
	LECS□2-T□	200 to 240	●	●	●
S1	LECSS1-S□	100 to 120	●	●	—
S2	LECSS2-S□	200 to 230	●	●	●
	LECSS2-T□	200 to 240	●	●	●
N2	LECSN2-T□	200 to 240	●	●	●
E2	LECSN2-T□-E	200 to 240	●	●	●
92	LECSN2-T□-9	200 to 240	●	●	●
P2	LECSN2-T□-P	200 to 240	●	●	●

\* When a driver type is selected, a cable is included. Select the cable type and cable length.

Example) S2S2: Standard cable (2 m) + Driver (LECSS2)  
S2: Standard cable (2 m)

Nil: Without cable and driver

#### Support Guide/11-LEFG Series

The support guide was designed to support workpieces with significant overhang. p. 651



#### Applicable Stroke Table

Model	Stroke [mm]																				
	50	100	150	200	250	300	350	400	450	500	550	600	650	700	750	800	850	900	950	1000	
11-LEFS25	●	●	●	●	●	●	●	●	●	●	●	●	●	—	—	—	—	—	—	—	—
11-LEFS32	●	●	●	●	●	●	●	●	●	●	●	●	●	●	●	●	●	●	●	●	—
11-LEFS40	—	—	●	●	●	●	●	●	●	●	●	●	●	●	●	●	●	●	●	●	●

\* Please consult with SMC for non-standard strokes as they are produced as special orders.

#### Compatible Drivers

Driver type	Pulse input type/ Positioning type	Pulse input type	CC-Link direct input type	SSCNET III type	Pulse input type	CC-Link direct input type	SSCNET III/H type	Network card type	
Series	LECSA	LECSB	LECS□	LECS□	LECSB-T	LECS□-T	LECSS-T	LECSN-T	
Number of point tables*1	Up to 7	—	Up to 255 (2 stations occupied)	—	Up to 255	Up to 255 (2 stations occupied)	—	Up to 255	
Pulse input	○	○	—	—	○	—	—	—	
Applicable network	—	—	CC-Link	SSCNET III	—	CC-Link	SSCNET III/H	PROFINET EtherCAT® EtherNet/IP™	
Control encoder	Incremental 17-bit encoder	Absolute 18-bit encoder	Absolute 18-bit encoder	Absolute 18-bit encoder	Absolute 22-bit encoder	Absolute 18-bit encoder	Absolute 22-bit encoder	Absolute 22-bit encoder	
Communication function	USB communication	USB communication	RS422 communication	USB communication	USB communication	RS422 communication	USB communication	USB communication	
Power supply voltage [V]	100 to 120 VAC (50/60 Hz), 200 to 230 VAC (50/60 Hz)   200 to 240 VAC (50/60 Hz)   200 to 230 VAC (50/60 Hz)   200 to 240 VAC (50/60 Hz)   200 to 240 VAC (50/60 Hz)								
Reference page	777								

\*1 The LECSN-T only supports PROFINET and EtherCAT®.

# 11-LEFS Series

AC Servo Motor

Clean Room Specification

## Specifications

### 11-LEFS25, 32, 40 AC Servo Motor

Model		11-LEFS25 $\frac{S}{6}$ /T6		11-LEFS32 $\frac{S}{7}$ /T7		11-LEFS40 $\frac{S}{8}$ /T8			
Actuator specifications	Stroke [mm] <sup>*1</sup>	50 to 600		50 to 800		150 to 1000			
	Work load [kg] <sup>*2</sup>	Horizontal	20	20	40	45	50	60	
		Vertical	8	15	10	20	15	30	
	Max. speed <sup>*3</sup> [mm/s]	Stroke range	Up to 400	900	450	1000	500	1000	500
			401 to 500	720	360	1000	500	1000	500
			501 to 600	540	270	800	400	1000	500
			601 to 700	—	—	620	310	940	470
			701 to 800	—	—	500	250	760	380
			801 to 900	—	—	—	—	620	310
		901 to 1000	—	—	—	—	520	260	
	Max. acceleration/deceleration [mm/s <sup>2</sup> ]	5000 (Refer to pages 41 to 43 for limit according to work load and duty ratio.)							
	Positioning repeatability [mm]	Basic type	±0.02						
		High-precision type	±0.01						
	Lost motion [mm] <sup>*4</sup>	Basic type	0.1 or less						
		High-precision type	0.05 or less						
Lead [mm]		12	6	16	8	20	10		
Impact/Vibration resistance [m/s <sup>2</sup> ] <sup>*5</sup>		50/20							
Actuation type		Ball screw							
Guide type		Linear guide							
Static allowable moment <sup>*6</sup> [N·m]	Mep (Pitching)	27		46		110			
	Mey (Yawing)	27		46		110			
	Mer (Rolling)	52		101		207			
Operating temperature range [°C]		5 to 40							
Operating humidity range [%RH]		90 or less (No condensation)							
Cleanliness class <sup>*7</sup>		ISO Class 4 (ISO 14644-1) Class 10 (Fed.Std.209E)							
Grease	Ball screw /Linear guide portion	Low particle generation grease							
Motor output/Size		100 W/□40		200 W/□60		400 W/□60			
Motor type		AC servo motor (100/200 VAC)							
Encoder <sup>*10</sup>		Motor type S2, S3, S4: Incremental 17-bit encoder (Resolution: 131072 p/rev) Motor type S6, S7, S8: Absolute 18-bit encoder (Resolution: 262144 p/rev) Motor type T6, T7, T8: Absolute 22-bit encoder (Resolution: 4194304 p/rev) (For LECSB2-T□, LECSS2-T□) Motor type T6, T7, T8: Absolute 18-bit encoder (Resolution: 262144 p/rev) (For LECSC2-T□)							
Power [W] <sup>*8</sup>		Max. power 445		Max. power 725		Max. power 1275			
Type <sup>*9</sup>		Non-magnetizing lock							
Holding force [N]		131	255	197	385	330	660		
Power consumption at 20°C [W]		6.3		7.9		7.9			
Rated voltage [V]		24 VDC <sup>0</sup> <sub>-10%</sub>							

- \*1 Please consult with SMC for non-standard strokes as they are produced as special orders.
- \*2 For details, refer to the "Speed-Work Load Graph (Guide)" on page 40.
- \*3 The allowable speed changes according to the stroke.
- \*4 A reference value for correcting an error in reciprocal operation
- \*5 Impact resistance: No malfunction occurred when the actuator was tested with a drop tester in both an axial direction and a perpendicular direction to the lead screw. (The test was performed with the actuator in the initial state.)  
Vibration resistance: No malfunction occurred in a test ranging between 45 to 2000 Hz. The test was performed in both an axial direction and a perpendicular direction to the lead screw. (The test was performed with the actuator in the initial state.)

- \*6 The static allowable moment is the amount of static moment which can be applied to the actuator when it is stopped.  
If the product is exposed to impact or repeated load, be sure to take adequate safety measures when using the product.
- \*7 The amount of particle generation changes according to the operating conditions and suction flow rate. Refer to the particle generation characteristics for details.
- \*8 Indicates the max. power during operation (including the driver)  
When selecting the power supply capacity, refer to the power supply capacity in the operation manual of each driver.
- \*9 Only when motor option "With lock" is selected
- \*10 For motor type T6, T7, and T8, the resolution will change depending on the driver type.

## Weight

Series		11-LEFS25 $\square$											
Stroke [mm]		50	100	150	200	250	300	350	400	450	500	550	600
Motor type	S2	2.00	2.14	2.28	2.44	2.56	2.69	2.84	2.99	3.12	3.24	3.40	3.54
	S6	2.06	2.20	2.34	2.50	2.62	2.75	2.90	3.05	3.18	3.30	3.46	3.60
	T6	2.04	2.18	2.32	2.48	2.60	2.73	2.88	3.03	3.16	3.28	3.44	3.58
Additional weight with lock [kg]		S2: 0.2/S6: 0.3/T6: 0.3											

Series		11-LEFS32 $\square$															
Stroke [mm]		50	100	150	200	250	300	350	400	450	500	550	600	650	700	750	800
Motor type	S3	3.40	3.60	3.80	4.00	4.20	4.40	4.60	4.80	5.00	5.20	5.40	5.60	5.80	6.00	6.20	6.40
	S7	3.34	3.54	3.74	3.94	4.14	4.34	4.54	4.74	4.94	5.14	5.34	5.54	5.74	5.94	6.14	6.34
	T7	3.31	3.51	3.71	3.91	4.11	4.31	4.51	4.71	4.91	5.11	5.31	5.51	5.71	5.91	6.11	6.31
Additional weight with lock [kg]		S3: 0.4/S7: 0.7/T7: 0.5															

Series		11-LEFS40 $\square$																	
Stroke [mm]		150	200	250	300	350	400	450	500	550	600	650	700	750	800	850	900	950	1000
Motor type	S4	5.82	6.10	6.38	6.65	6.95	7.25	7.51	7.80	8.07	8.25	8.63	8.90	9.20	9.45	9.76	10.05	10.32	10.60
	S8	5.92	6.20	6.48	6.75	7.05	7.35	7.61	7.90	8.17	8.35	8.73	9.00	9.30	9.55	9.86	10.15	10.42	10.70
	T8	5.91	6.19	6.47	6.74	7.04	7.34	7.60	7.89	8.16	8.34	8.72	8.99	9.29	9.54	9.85	10.14	10.41	10.69
Additional weight with lock [kg]		S4: 0.5/S8: 0.7/T8: 0.5																	

# Electric Actuator/Slider Type Ball Screw Drive Clean Room Specification

## 11-LEFS Series LEFS25, 32, 40

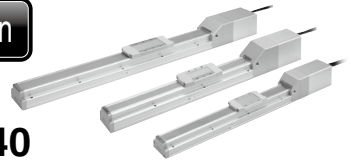

Refer to page 47 for model selection and page 632 for particle generation characteristics.

Click here for details.

LECS □ Series ▶ p. 644

### How to Order

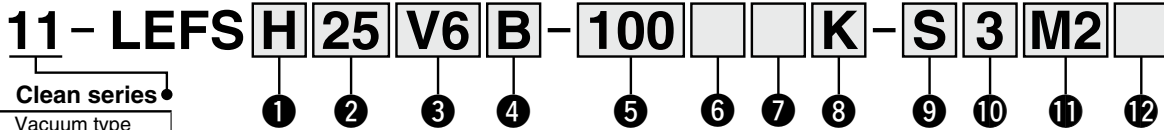

#### ① Accuracy

Nil	Basic type
H	High-precision type

#### ② Size

25
32
40

#### ④ Lead [mm]

Symbol	11-LEFS25	11-LEFS32	11-LEFS40
A	12	16	20
B	6	8	10

#### ⑤ Stroke [mm]

50 to 1000	50 to 1000
------------	------------

\* For details, refer to the applicable stroke table below.

#### ⑥ Motor option

Nil	Without option
B	With lock

#### ③ Motor type

Symbol	Type	Output [W]	Size	Compatible drivers
V6*1	AC servo motor (Absolute encoder)	100	25	LECYM2-V5/LECYU2-V5
V7		200	32	LECYM2-V7/LECYU2-V7
V8		400	40	LECYM2-V8/LECYU2-V8

\*1 For motor type V6, the compatible driver part number suffix is V5.

#### ⑨ Cable type\*1 \*2

Nil	Without cable
S	Standard cable
R	Robotic cable (Flexible cable)

\*1 The motor and encoder cables are included. (The lock cable is also included when the motor with lock option is selected.)

\*2 Standard cable entry direction is "(B) Counter axis side." (Refer to page 796 for details.)

#### ⑩ Actuator cable length [m]

Nil	Without cable
3	3
5	5
A	10
C	20

#### ⑧ Positioning pin hole

Nil	Housing B bottom*1	
K	Body bottom 2 locations	

\*1 Refer to the body mounting example on page 166 for the mounting method.

#### ⑫ I/O cable length [m]\*1

Nil	Without cable
H	Without cable (Connector only)
1	1.5

\*1 When "Without driver" is selected for driver type, only "Nil: Without cable" can be selected. Refer to page 797 if I/O cable is required. (Options are shown on page 797.)

#### ⑦ Vacuum port\*1

Nil	Left
R	Right
D	Both left and right

\*1 Select "D" for the vacuum port for suction of 50 L/min (ANR) or more.

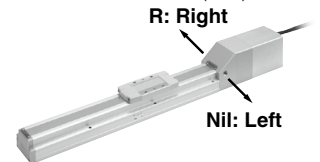

#### ⑪ Driver type

	Compatible drivers	Power supply voltage [V]
Nil	Without driver	—
M2	LECYM2-V□	200 to 230
U2	LECYU2-V□	200 to 230

#### Applicable Stroke Table

Model	Stroke [mm]																					
	50	100	150	200	250	300	350	400	450	500	550	600	650	700	750	800	850	900	950	1000		
11-LEFS25	●	●	●	●	●	●	●	●	●	●	●	●	●	—	—	—	—	—	—	—	—	
11-LEFS32	●	●	●	●	●	●	●	●	●	●	●	●	●	●	●	●	●	●	—	—	—	—
11-LEFS40	—	—	●	●	●	●	●	●	●	●	●	●	●	●	●	●	●	●	●	●	●	●

\* Please consult with SMC for non-standard strokes as they are produced as special orders.

#### Support Guide/11-LEFG Series

The support guide was designed to support workpieces with significant overhang. [p. 651](#)

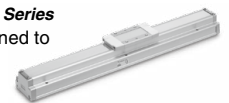

#### Compatible Drivers

Driver type	MECHATROLINK-II type	MECHATROLINK-III type
Series	LECYM	LECYU
Applicable network	MECHATROLINK-II	MECHATROLINK-III
Control encoder	Absolute 20-bit encoder	
Communication device	USB communication, RS-422 communication	
Power supply voltage [V]	200 to 230 VAC (50/60 Hz)	
Reference page	801	

LEFS  
LEFB  
LEJS  
LEJB  
LEL  
LEM  
LEY  
LEYG  
LES  
LESH  
LEPY  
LEPS  
LER  
LEH  
LEH-X5  
LEY-X5  
11-LEFS  
11-LEJS  
25A-  
LEC  
JXC  
LECS  
LECS-T  
LECY  
Motorless  
LAT3



# 11-LEFS Series

AC Servo Motor

Clean Room Specification

## Specifications

### AC Servo Motor

Model			11-LEFS25□V6				11-LEFS32□V7				11-LEFS40□V8								
Actuator specifications	Stroke [mm] <sup>*1</sup>		50 to 800				50 to 1000				150 to 1200								
	Work load [kg] <sup>*2</sup>		Horizontal		20	20	40	45	50	60	Vertical		8	15	10	20	15	30	
			Up to 400		900	450	1000	500	1000	500	401 to 500		720	360	1000	500	1000	500	
	Max. speed [mm/s] <sup>*3</sup>		501 to 600		540	270	800	400	1000	500	601 to 700		420	210	620	310	940	470	
			701 to 800		330	160	500	250	760	380	801 to 900		—	—	410	200	620	310	
			901 to 1000		—	—	340	170	520	260	1001 to 1100		—	—	—	—	440	220	
			1101 to 1200		—	—	—	—	380	190	Max. acceleration/deceleration [mm/s <sup>2</sup> ]		20000 (Refer to pages 41 to 43 for limit according to work load and duty ratio.)						
			Positioning repeatability [mm]		Basic type		±0.02												
					High-precision type		±0.01												
			Lost motion [mm] <sup>*4</sup>		Basic type		0.1 or less												
	High-precision type				0.05 or less														
	Lead [mm]		12	6	16	8	20	10	Impact/Vibration resistance [m/s <sup>2</sup> ] <sup>*5</sup>		50/20								
	Actuation type		Ball screw (LEFS□), Ball screw + Belt (LEFS□ <sup>Ⓡ</sup> )																
	Guide type		Linear guide																
	Static allowable moment <sup>*6</sup> [N·m]		Mep (Pitching)		27	46	110	Mey (Yawing)		27	46	110	Mer (Rolling)		52	101	207		
			Operating temperature range [°C]		5 to 40														
			Operating humidity range [%RH]		90 or less (No condensation)														
Cleanliness class <sup>*7</sup>		ISO Class 4 (ISO 14644-1) Class 10 (Fed.Std.209E)																	
Grease	Ball screw /Linear guide portion		Low particle generation grease																
Electric specifications	Motor output/Size		100 W/□40				200 W/□60				400 W/□60								
	Motor type		AC servo motor (200 VAC)																
	Encoder		Absolute 20-bit encoder (Resolution: 1048576 p/rev)																
	Power [W] <sup>*8</sup>		Max. power 445				Max. power 725				Max. power 1275								
Lock unit specifications	Type <sup>*9</sup>		Non-magnetizing lock																
	Holding force [N]		131	255	197	385	330	660	Power consumption at 20°C [W]		5.5	6	6						
	Rated voltage [V]		24 VDC <sup>+10%</sup> / <sub>0</sub>																

- \*1 Please consult with SMC for non-standard strokes as they are produced as special orders.
- \*2 For details, refer to the "Speed-Work Load Graph (Guide)" on page 48.
- \*3 The allowable speed changes according to the stroke.
- \*4 A reference value for correcting an error in reciprocal operation
- \*5 Impact resistance: No malfunction occurred when the actuator was tested with a drop tester in both an axial direction and a perpendicular direction to the lead screw. (The test was performed with the actuator in the initial state.)  
Vibration resistance: No malfunction occurred in a test ranging between 45 to 2000 Hz. The test was performed in both an axial direction and a perpendicular direction to the lead screw. (The test was performed with the actuator in the initial state.)

- \*6 The static allowable moment is the amount of static moment which can be applied to the actuator when it is stopped.  
If the product is exposed to impact or repeated load, be sure to take adequate safety measures when using the product.
- \*7 The amount of particle generation changes according to the operating conditions and suction flow rate. Refer to the particle generation characteristics for details.
- \*8 Indicates the max. power during operation (including the driver)  
When selecting the power supply capacity, refer to the power supply capacity in the operation manual of each driver.
- \*9 Only when motor option "With lock" is selected

## Weight

Series	11-LEFS25□V6															
Stroke [mm]	50	100	150	200	250	300	350	400	450	500	550	600	650	700	750	800
Product weight [kg]	2.06	2.20	2.34	2.50	2.62	2.75	2.90	3.05	3.18	3.30	3.46	3.60	3.74	3.88	4.02	4.20
Additional weight with lock [kg]	0.3															

Series	11-LEFS32□V7																			
Stroke [mm]	50	100	150	200	250	300	350	400	450	500	550	600	650	700	750	800	850	900	950	1000
Product weight [kg]	3.40	3.60	3.80	4.00	4.20	4.40	4.60	4.80	5.00	5.20	5.40	5.60	5.80	6.00	6.20	6.40	6.60	6.80	7.00	7.20
Additional weight with lock [kg]	0.7																			

Series	11-LEFS40□V8																			
Stroke [mm]	150	200	250	300	350	400	450	500	550	600	650	700	750	800	850	900	950	1000	1100	1200
Product weight [kg]	5.92	6.20	6.48	6.75	7.05	7.35	7.61	7.90	8.17	8.35	8.73	9.00	9.30	9.55	9.86	10.15	10.42	10.70	11.26	11.82
Additional weight with lock [kg]	0.7																			

**Dimensions: Ball Screw Drive**

**11-LEFS25**

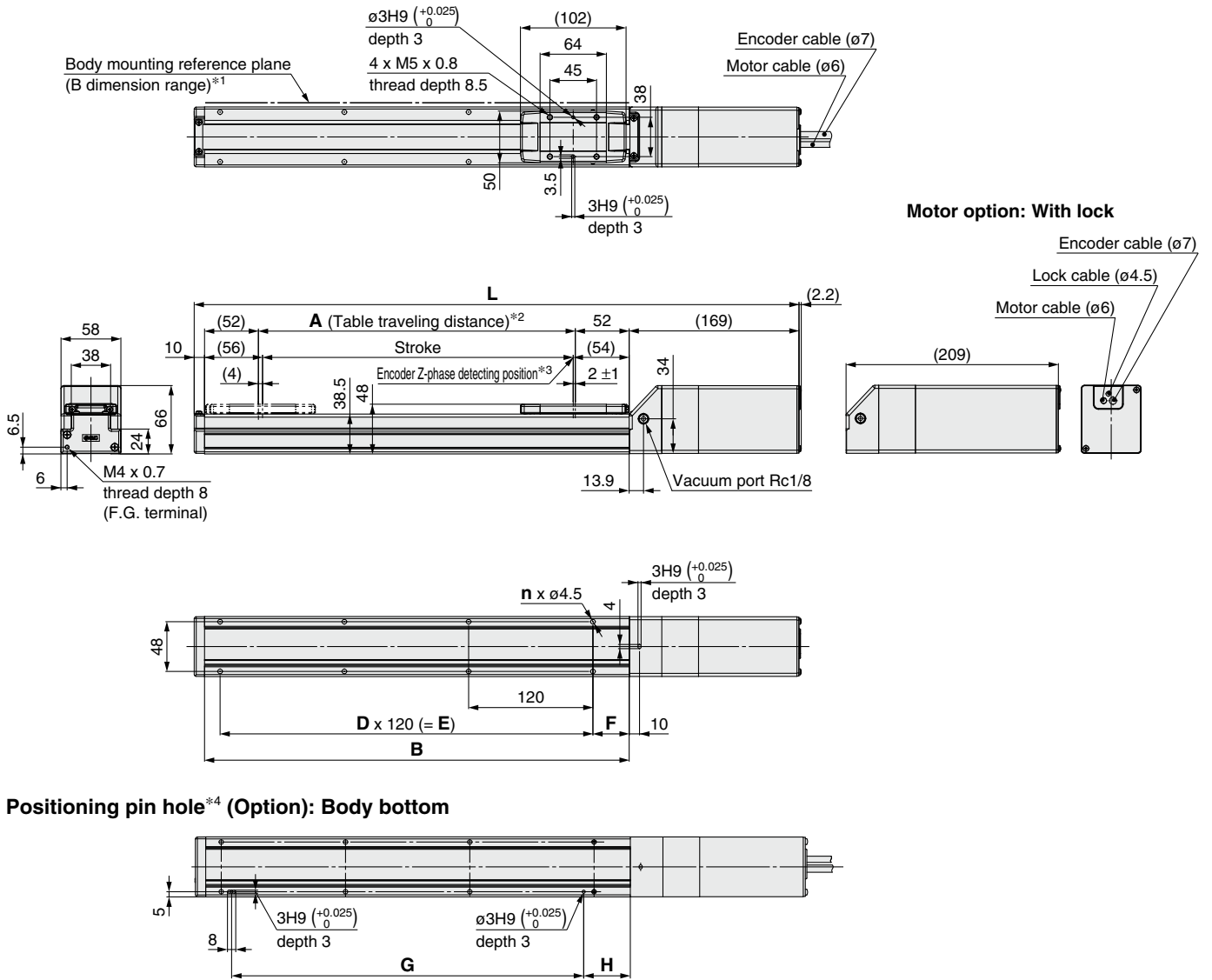

**Positioning pin hole\*4 (Option): Body bottom**

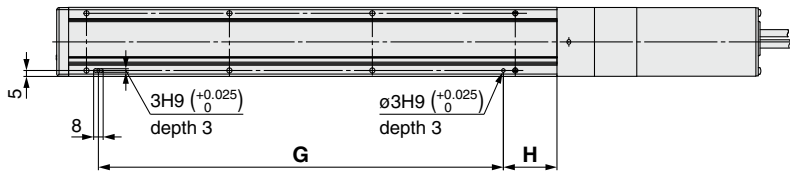

- \*1 When mounting the actuator using the body mounting reference plane, set the height of the opposite surface or pin to be 3 mm or more because of round chamfering. (Recommended height 5 mm)  
In addition, be aware that surfaces other than the body mounting reference plane (B dimension range) may slightly protrude from the body mounting reference plane. Be sure to provide a clearance of 1 mm or more to avoid interference with workpieces, facilities, etc.
- \*2 This is the distance within which the table can move when it returns to origin.  
Make sure workpieces mounted on the table do not interfere with the workpieces and facilities around the table.
- \*3 The Z-phase first detecting position from the stroke end of the motor side
- \*4 When using the body bottom positioning pin holes, do not simultaneously use the housing B bottom pin hole.

**Dimensions**

Model	L		A	B	n	D	E	F	G	H
	Without lock	With lock								
11-LEFS25□□-50□	339	379	56	160	4	—	—	20	100	30
11-LEFS25□□-100□	389	429	106	210	4	—	—	35	100	45
11-LEFS25□□-150□	439	479	156	260	4	—	—		100	45
11-LEFS25□□-200□	489	529	206	310	6	2	240		220	45
11-LEFS25□□-250□	539	579	256	360	6	2	240		220	45
11-LEFS25□□-300□	589	629	306	410	8	3	360		340	45
11-LEFS25□□-350□	639	679	356	460	8	3	360		340	45
11-LEFS25□□-400□	689	729	406	510	8	3	360		340	45
11-LEFS25□□-450□	739	779	456	560	10	4	480		460	45
11-LEFS25□□-500□	789	829	506	610	10	4	480		460	45
11-LEFS25□□-550□	839	879	556	660	12	5	600		580	45
11-LEFS25□□-600□	889	929	606	710	12	5	600		580	45

- LEFS
- LEFB
- LEJS
- LEJB
- LEL
- LEM
- LEYG
- LESH
- LEPS
- LER
- LEH
- LEY-X5
- 11-LEFS
- 11-LEJS
- 25A-
- LEC□
- JXC□
- LECS□-T
- LECY□
- Motorless
- LAT3

# 11-LEFS Series

AC Servo Motor

Clean Room Specification

## Dimensions: Ball Screw Drive

### 11-LEFS32

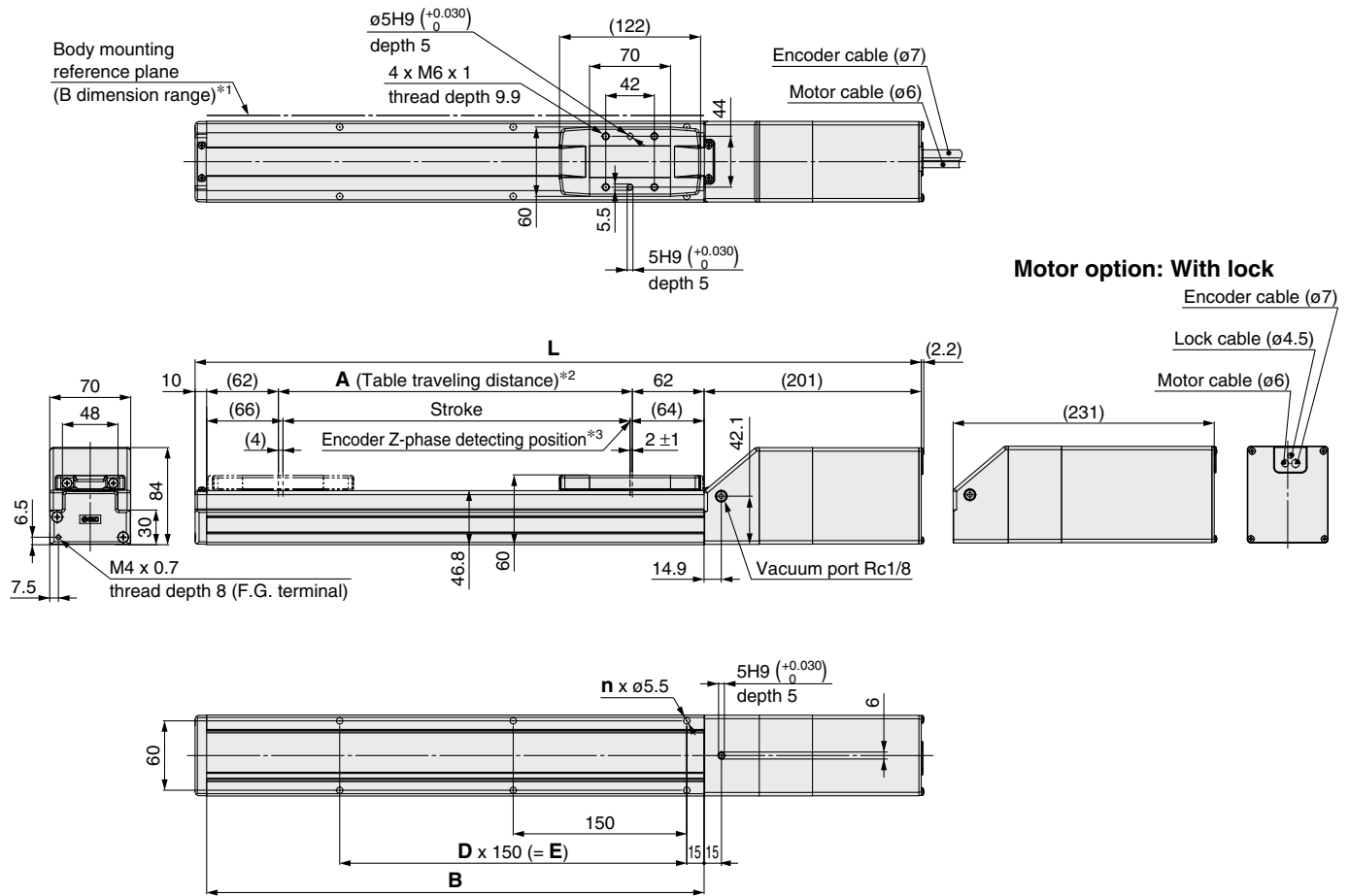

#### Motor option: With lock

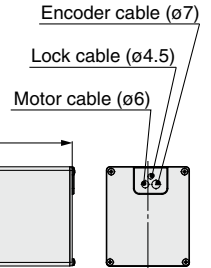

#### Positioning pin hole\*4 (Option): Body bottom

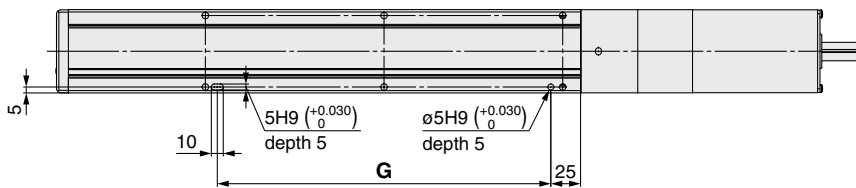

- \*1 When mounting the actuator using the body mounting reference plane, set the height of the opposite surface or pin to be 3 mm or more because of round chamfering. (Recommended height 5 mm)  
In addition, be aware that surfaces other than the body mounting reference plane (B dimension range) may slightly protrude from the body mounting reference plane. Be sure to provide a clearance of 1 mm or more to avoid interference with workpieces, facilities, etc.
- \*2 This is the distance within which the table can move when it returns to origin. Make sure workpieces mounted on the table do not interfere with the workpieces and facilities around the table.
- \*3 The Z-phase first detecting position from the stroke end of the motor side
- \*4 When using the body bottom positioning pin holes, do not simultaneously use the housing B bottom pin hole.

#### Dimensions

[mm]

Model	L		A	B	n	D	E	G
	Without lock	With lock						
11-LEFS32□□-50□	391	421	56	180	4	—	—	130
11-LEFS32□□-100□	441	471	106	230	4	—	—	130
11-LEFS32□□-150□	491	521	156	280	4	—	—	130
11-LEFS32□□-200□	541	571	206	330	6	2	300	280
11-LEFS32□□-250□	591	621	256	380	6	2	300	280
11-LEFS32□□-300□	641	671	306	430	6	2	300	280
11-LEFS32□□-350□	691	721	356	480	8	3	450	430
11-LEFS32□□-400□	741	771	406	530	8	3	450	430
11-LEFS32□□-450□	791	821	456	580	8	3	450	430
11-LEFS32□□-500□	841	871	506	630	10	4	600	580
11-LEFS32□□-550□	891	921	556	680	10	4	600	580
11-LEFS32□□-600□	941	971	606	730	10	4	600	580
11-LEFS32□□-650□	991	1021	656	780	12	5	750	730
11-LEFS32□□-700□	1041	1071	706	830	12	5	750	730
11-LEFS32□□-750□	1091	1121	756	880	12	5	750	730
11-LEFS32□□-800□	1141	1171	806	930	14	6	900	880

**Dimensions: Ball Screw Drive**

**11-LEFS40**

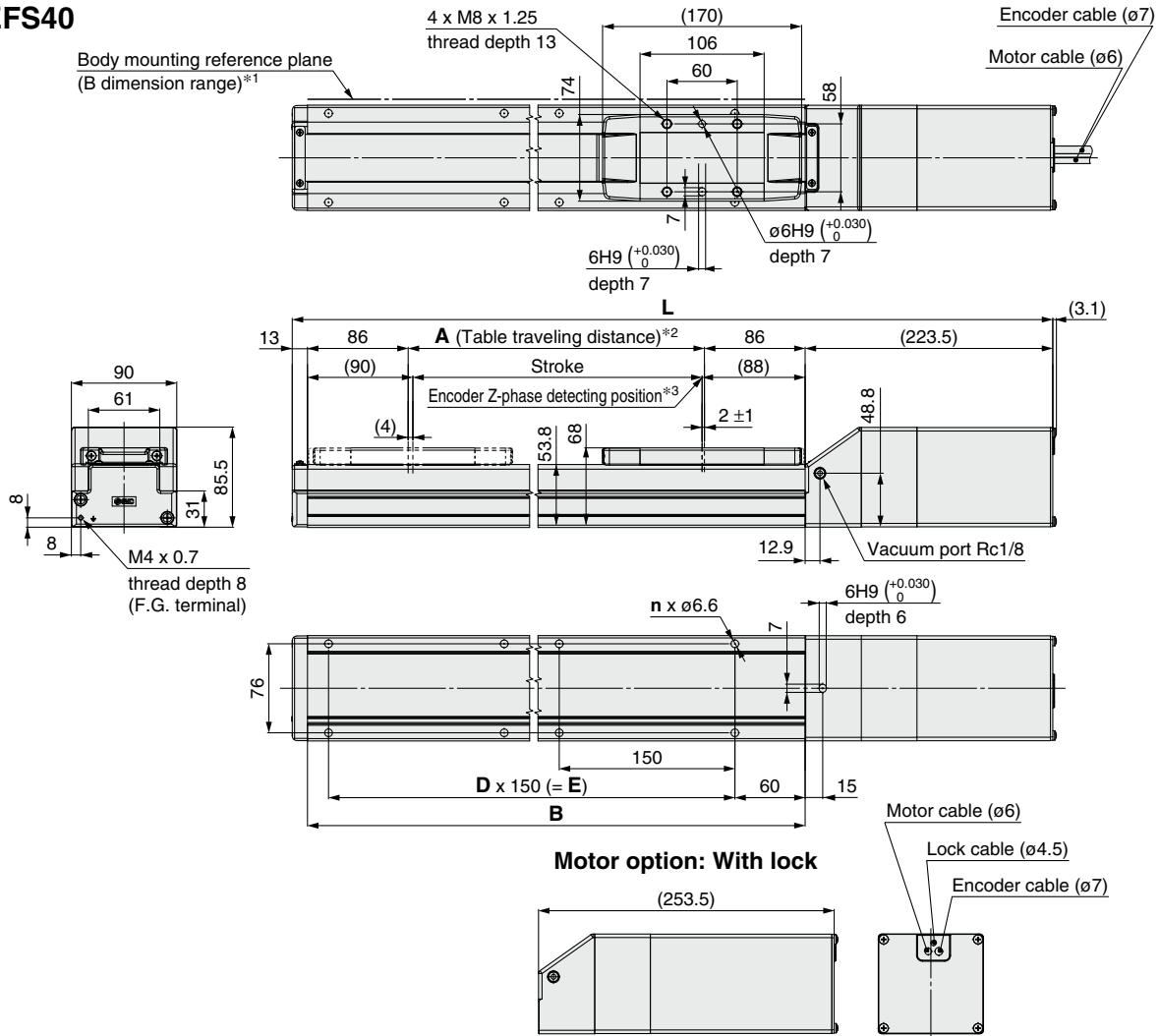

**Positioning pin hole\*4 (Option): Body bottom**

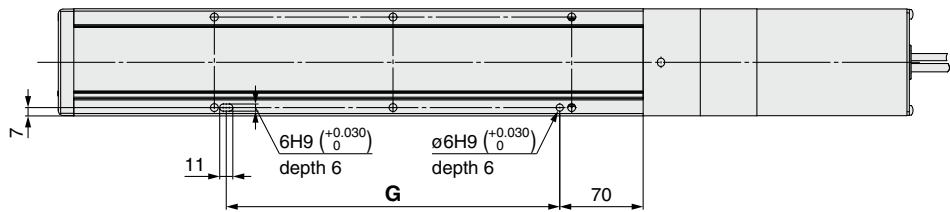

\*1 When mounting the actuator using the body mounting reference plane, set the height of the opposite surface or pin to be 3 mm or more because of round chamfering.  
(Recommended height 5 mm)

In addition, be aware that surfaces other than the body mounting reference plane (B dimension range) may slightly protrude from the body mounting reference plane. Be sure to provide a clearance of 1 mm or more to avoid interference with workpieces, facilities, etc.

\*2 This is the distance within which the table can move when it returns to origin. Make sure workpieces mounted on the table do not interfere with the workpieces and facilities around the table.

\*3 The Z-phase first detecting position from the stroke end of the motor side

\*4 When using the body bottom positioning pin holes, do not simultaneously use the housing B bottom pin hole.

**Dimensions**

Model	L		A	B	n	D	E	G
	Without lock	With lock						
11-LEFS40□□-150□	564.5	594.5	156	328	4	—	150	130
11-LEFS40□□-200□	614.5	644.5	206	378	6	2	300	280
11-LEFS40□□-250□	664.5	694.5	256	428	6	2	300	280
11-LEFS40□□-300□	714.5	744.5	306	478	6	2	300	280
11-LEFS40□□-350□	764.5	794.5	356	528	8	3	450	430
11-LEFS40□□-400□	814.5	844.5	406	578	8	3	450	430
11-LEFS40□□-450□	864.5	894.5	456	628	8	3	450	430
11-LEFS40□□-500□	914.5	944.5	506	678	10	4	600	580
11-LEFS40□□-550□	964.5	994.5	556	728	10	4	600	580
11-LEFS40□□-600□	1014.5	1044.5	606	778	10	4	600	580
11-LEFS40□□-650□	1064.5	1094.5	656	828	12	5	750	730
11-LEFS40□□-700□	1114.5	1144.5	706	878	12	5	750	730
11-LEFS40□□-750□	1164.5	1194.5	756	928	12	5	750	730
11-LEFS40□□-800□	1214.5	1244.5	806	978	14	6	900	880
11-LEFS40□□-850□	1264.5	1294.5	856	1028	14	6	900	880
11-LEFS40□□-900□	1314.5	1344.5	906	1078	14	6	900	880
11-LEFS40□□-950□	1364.5	1394.5	956	1128	16	7	1050	1030
11-LEFS40□□-1000□	1414.5	1444.5	1006	1178	16	7	1050	1030

# Support Guide

## 11-LEFG Series 11-LEFG16, 25, 32, 40

RoHS

### Application example

The support guide was designed to support workpieces with significant overhang.

- As the dimensions are the same as the 11-LEF series body, installation is simple and contributes to a reduction in installation and assembly labor.
- The standard-equipped seal bands prevent grease from splashing and external foreign matter from entering.

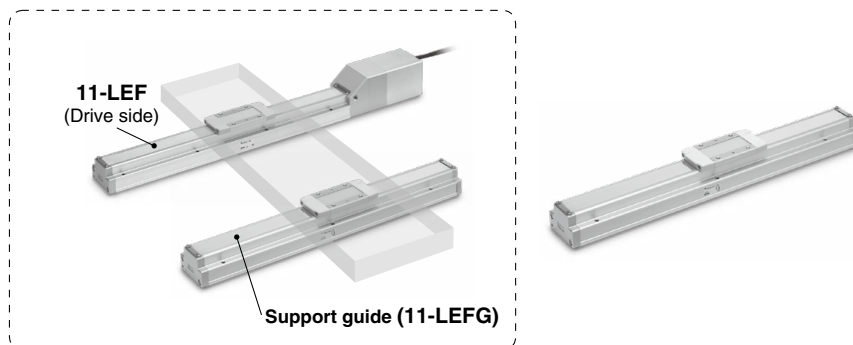

### How to Order

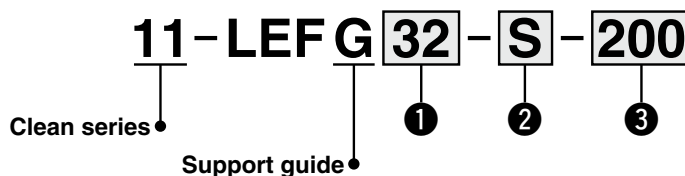

#### ① Size

16
25
32
40

#### ② Type of mounting pitch

Symbol	11-LEFG16	11-LEFG25	11-LEFG32	11-LEFG40	Note
S	●	●	●	●	Ball screw drive Step motor/Servo motor (24 VDC)/AC servo motor

#### ③ Stroke [mm]

50	50
to	to
1000	1000

### Applicable Stroke Table

#### Ball Screw Drive: S

Step Motor (Servo/24 VDC)    Servo Motor (24 VDC)    AC Servo Motor

Model \ Stroke [mm]	50	100	150	200	250	300	350	400	450	500	550	600	650	700	750	800	850	900	950	1000
11-LEFG16-S	●	●	●	●	●	●	●	●	●	●	—	—	—	—	—	—	—	—	—	—
11-LEFG25-S	●	●	●	●	●	●	●	●	●	●	●	●	—	—	—	—	—	—	—	—
11-LEFG32-S	●	●	●	●	●	●	●	●	●	●	●	●	●	●	●	●	—	—	—	—
11-LEFG40-S	—	—	●	●	●	●	●	●	●	●	●	●	●	●	●	●	●	●	●	●

### Weight

#### Ball Screw Drive: S

Step Motor (Servo/24 VDC)    Servo Motor (24 VDC)    AC Servo Motor

Model \ Stroke [mm]	50	100	150	200	250	300	350	400	450	500	550	600	650	700	750	800	850	900	950	1000
11-LEFG16-S	0.25	0.31	0.37	0.43	0.49	0.55	0.61	0.67	0.73	0.79	—	—	—	—	—	—	—	—	—	—
11-LEFG25-S	0.56	0.67	0.78	0.89	1.00	1.11	1.22	1.33	1.44	1.55	1.66	1.77	—	—	—	—	—	—	—	—
11-LEFG32-S	0.92	1.08	1.23	1.4	1.56	1.72	1.88	2.04	2.20	2.36	2.52	2.88	2.84	3.00	3.16	3.22	—	—	—	—
11-LEFG40-S	—	—	2.07	2.29	2.51	2.72	2.94	3.15	3.37	3.58	3.80	4.01	4.23	4.44	4.66	4.87	5.09	5.30	5.52	5.73

**Dimensions: Ball Screw Drive**

**11-LEFG16-S**

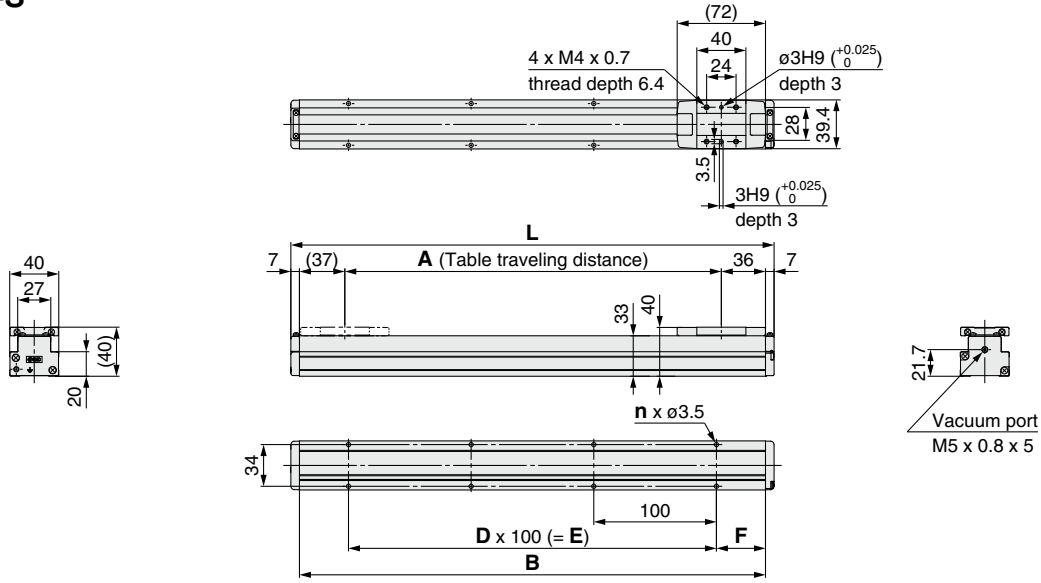

**Dimensions**

Model	L	A	B	n	D	E	F
11-LEFG16-S-50	144	57	130	4	—	—	15
11-LEFG16-S-100	194	107	180				
11-LEFG16-S-150	244	157	230				
11-LEFG16-S-200	294	207	280	6	2	200	40
11-LEFG16-S-250	344	257	330				
11-LEFG16-S-300	394	307	380				
11-LEFG16-S-350	444	357	430	8	3	300	40
11-LEFG16-S-400	494	407	480				
11-LEFG16-S-450	544	457	530				
11-LEFG16-S-500	594	507	580	12	5	500	

**11-LEFG25-S**

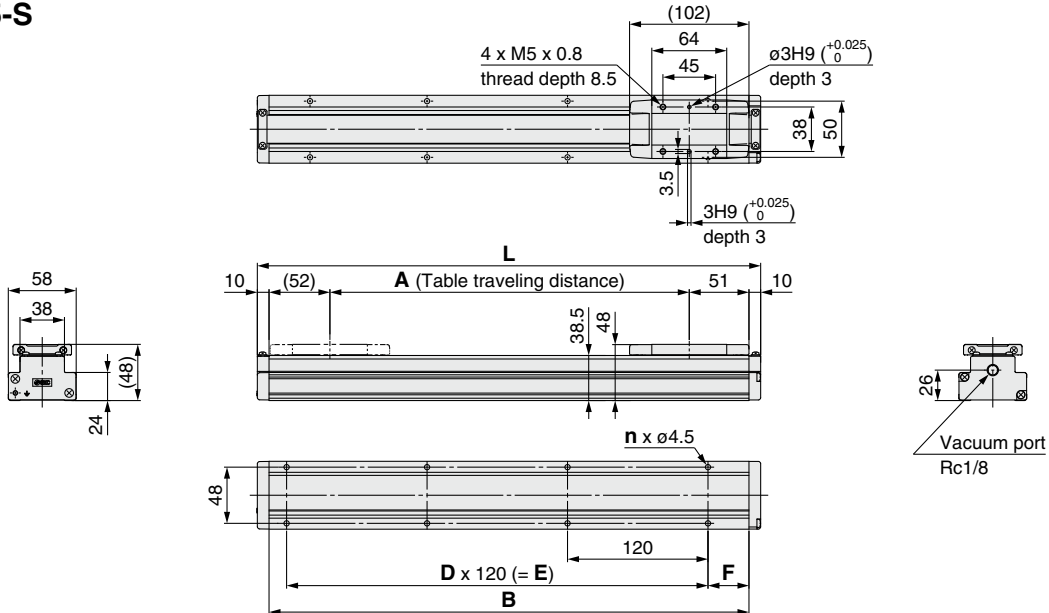

**Dimensions**

Model	L	A	B	n	D	E	F
11-LEFG25-S-50	180	57	160	4	—	—	20
11-LEFG25-S-100	230	107	210				
11-LEFG25-S-150	280	157	260				
11-LEFG25-S-200	330	207	310	6	2	240	35
11-LEFG25-S-250	380	257	360				
11-LEFG25-S-300	430	307	410				
11-LEFG25-S-350	480	357	460	8	3	360	
11-LEFG25-S-400	530	407	510				

**Dimensions**

Model	L	A	B	n	D	E	F
11-LEFG25-S-450	580	457	560	10	4	480	35
11-LEFG25-S-500	630	507	610				
11-LEFG25-S-550	680	557	660	12	5	600	
11-LEFG25-S-600	730	607	710				

- LEFS
- LEFB
- LEJS
- LEJB
- LEL
- LEM
- LEY
- LEYG
- LES
- LESH
- LEPY
- LEPS
- LER
- LEH
- LEY-X5
- 11-LEFS
- 11-LEJS
- 25A-
- LEC
- JXC
- LECS
- LECS-T
- LECY
- Motorless
- LAT3

# 11-LEFG Series

## Dimensions: Ball Screw Drive

### 11-LEFG32-S

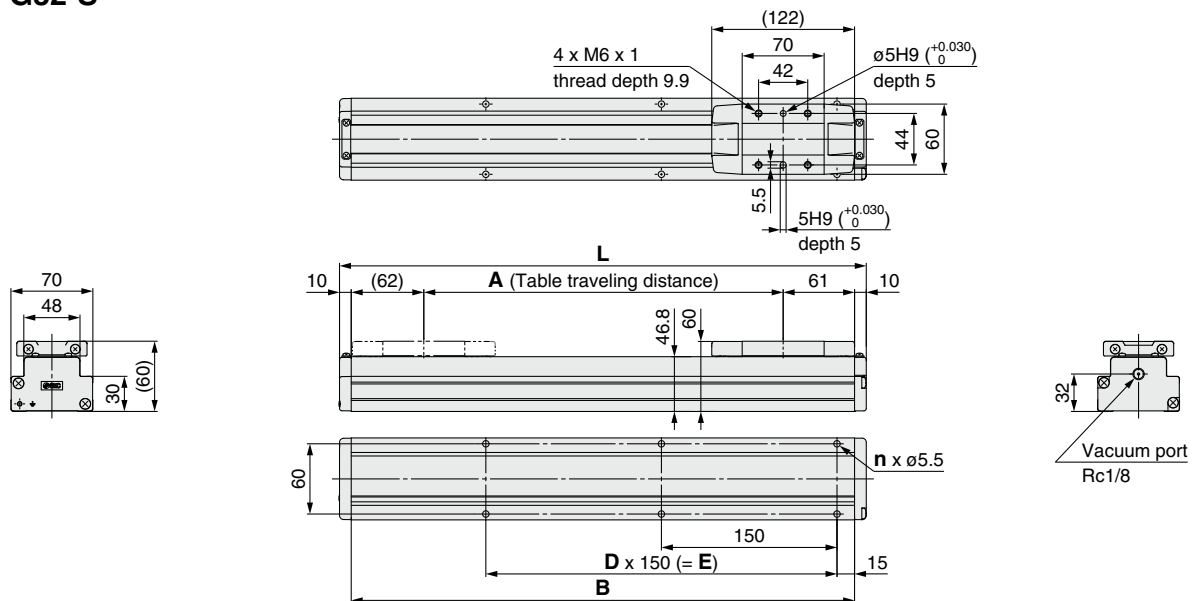

#### Dimensions

Model	L	A	B	n	D	E
11-LEFG32-S-50	200	57	180	4	—	—
11-LEFG32-S-100	250	107	230			
11-LEFG32-S-150	300	157	280			
11-LEFG32-S-200	350	207	330	6	2	300
11-LEFG32-S-250	400	257	380			
11-LEFG32-S-300	450	307	430			
11-LEFG32-S-350	500	357	480	8	3	450
11-LEFG32-S-400	550	407	530			
11-LEFG32-S-450	600	457	580			

#### Dimensions

Model	L	A	B	n	D	E
11-LEFG32-S-500	650	507	630	10	4	600
11-LEFG32-S-550	700	557	680			
11-LEFG32-S-600	750	607	730			
11-LEFG32-S-650	800	657	780	12	5	750
11-LEFG32-S-700	850	707	830			
11-LEFG32-S-750	900	757	880			
11-LEFG32-S-800	950	807	930	14	6	900

**Dimensions: Ball Screw Drive**

**11-LEFG40-S**

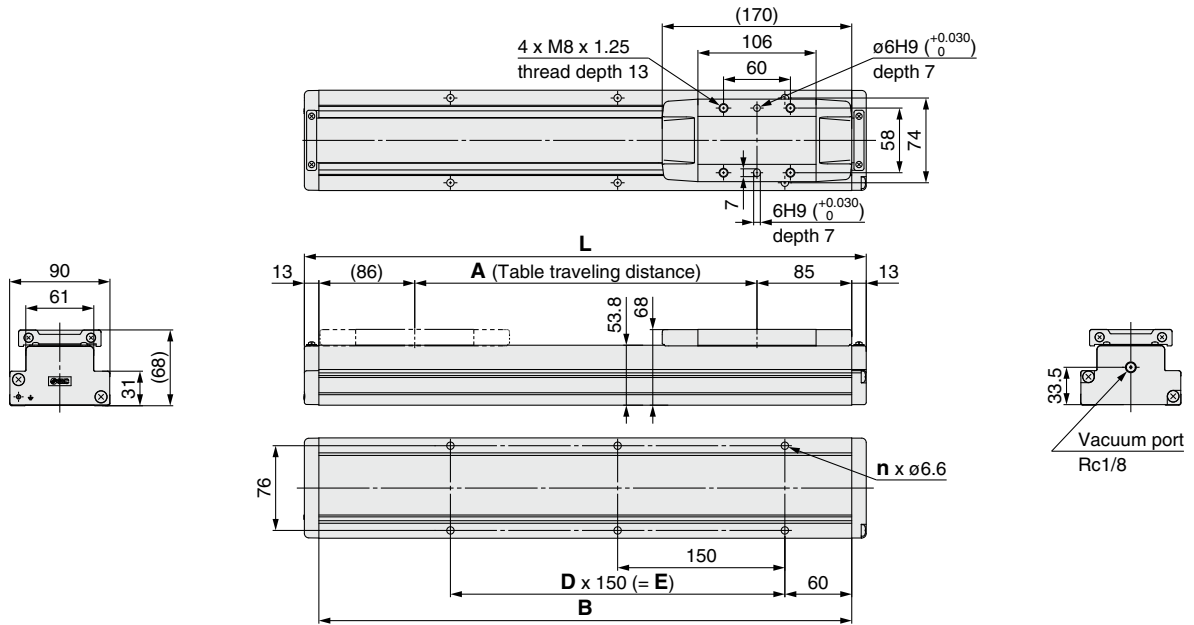

**Dimensions**

Model	L	A	B	n	D	E
11-LEFG40-S-150	354	157	328	4	—	150
11-LEFG40-S-200	404	207	378	6	2	300
11-LEFG40-S-250	454	257	428			
11-LEFG40-S-300	504	307	478	8	3	450
11-LEFG40-S-350	554	357	528			
11-LEFG40-S-400	604	407	578			
11-LEFG40-S-450	654	457	628	10	4	600
11-LEFG40-S-500	704	507	678			
11-LEFG40-S-550	754	557	728			
11-LEFG40-S-600	804	607	778			

**Dimensions**

Model	L	A	B	n	D	E
11-LEFG40-S-650	854	657	828	12	5	750
11-LEFG40-S-700	904	707	878			
11-LEFG40-S-750	954	757	928	14	6	900
11-LEFG40-S-800	1004	807	978			
11-LEFG40-S-850	1054	857	1028			
11-LEFG40-S-900	1104	907	1078	16	7	1050
11-LEFG40-S-950	1154	957	1128			
11-LEFG40-S-1000	1204	1007	1178			

LEFS  
LEFB

LEJS  
LEJB

LEL

LEM

LEY  
LEYG

LES  
LESH

LEPY  
LEPS

LER

LEH

LEY-X5

11-LEFS

11-LEJS

25A-

LEC

JXC

LECS  
LECS-T

LECY

Motorless

LAT3