

Power Clamp Cylinder

ø50, ø63

- Simple switch adjustment greatly reduces work hours. Switch can be adjusted easily when changing the arm opening angle.

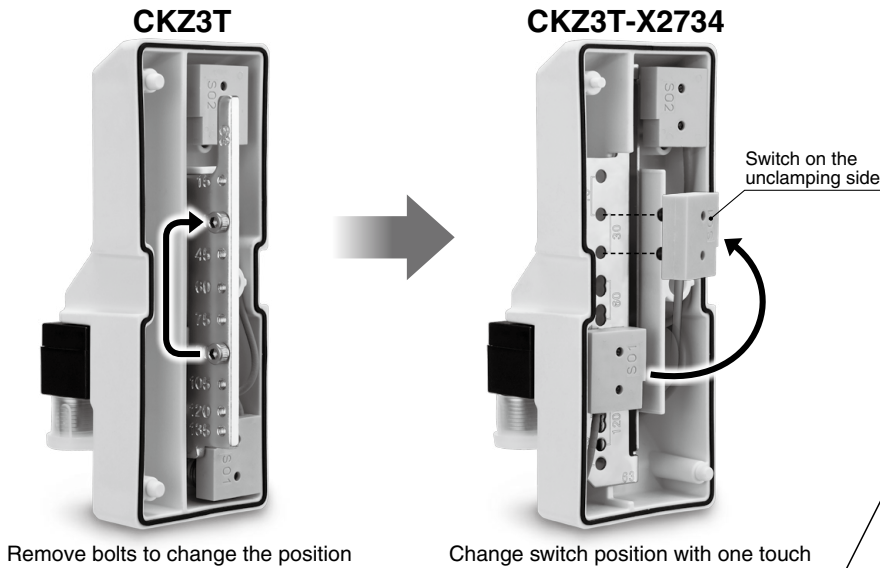

- With metal switch cassette cover
 - Protects switch cassette from unexpected impact

- Weight reduced by up to **39%**
 - Aluminum body with greatly reduced weight
 - Suitable for robot material handling

Bore size	CKZT → CKZ3T-X2734	Reduction rate
50	5.0 kg → 3.1 kg	38% reduction
63	7.1 kg → 4.3 kg	39% reduction

* Arm opening angle: 90°

- High clamping force **4000 N**

(ø63, Arm length: 100 mm, 0.5 MPa pressure)

New

A model with a manually operated handle is available.

- For manual workpiece setting processes

Manually operated handle
(Unclamping position)

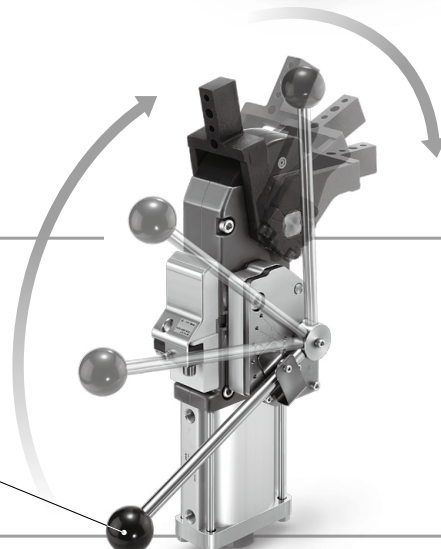

CKZ3T-X2734 (Base Type)
CKZ3T-X2568 (With Manually Operated Handle)



Power Clamp Cylinder

CKZ3T-X2734

CKZ3T-X2568

ø50, ø63

How to Order

Base type

CKZ3T 50 - 90 T - X2734

With manually operated handle

CKZ3T 50 - 90 T - X2568 L

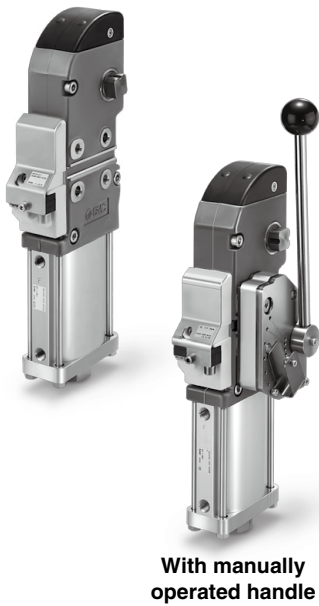

With manually operated handle

Bore size

50	ø50 equivalent
63	ø63 equivalent

Cylinder port

Nil	G
TN	NPT
TP	Rc

Arm opening angle

Symbol	Arm opening angle	X2734	X2568
15	15°	○	○
30	30°	○	○
45	45°	○	○
60	60°	○	○
75	75°	○	○
90	90°	○	○
105	105°	○	○
120	120°	○	○
135	135°	○	—

Top cover

Nil	Rubber cover (Equivalent to UL94 Standard V0: Flame resistant)
M	Metal cover

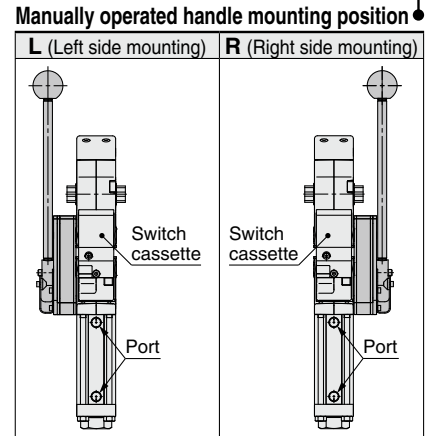

* Switch cassette viewed from the front.

Proximity switch

T	TURCK
P	P&F
W	None

Clamp arm

CKZT 50 - A015 C S

Bore size

50	ø50 equivalent
63	ø63 equivalent

Offset

A015	Offset 15 mm
A045	Offset 45 mm

Mounting hole

Symbol	D1	D2
S	6	9
B	8	10.2

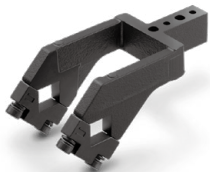

Mounted arm

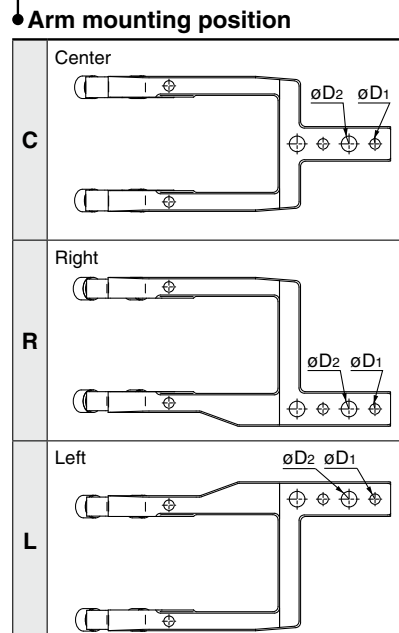

Cylinder Specifications

Bore size	50	63
Action	Double acting	
Fluid	Air	
Proof pressure	1.2 MPa	
Max. operating pressure	0.8 MPa	
Min. operating pressure	0.3 MPa	
Ambient and fluid temperatures	-10 to 60°C (No freezing)	
Cushion	Clamping side: None Unclamping side: Rubber bumper	
Operating time	Clamping: 1 s or more, Unclamping: 1 s or more	
Max. allowable clamping moment*1	800 N·m	1500 N·m

*1 Refer to the maximum holding force (torque) while clamped with the operating air exhausted.
This is not the possible holding force (torque) for normal use.

Weight (Cylinder Without Clamp Arm)

Bore size	Arm opening angle									Additional weight of the manually operated handle
	15°	30°	45°	60°	75°	90°	105°	120°	135°	
50	3.2	3.2	3.1	3.1	3.1	3.1	3.1	3.1	3.0	1.7
63	4.4	4.4	4.3	4.3	4.3	4.3	4.2	4.2	4.2	1.7

* Refer to pages 6 and 7 for the weight of clamp arms.

Cylinder Stroke

Bore size	Arm opening angle								
	15°	30°	45°	60°	75°	90°	105°	120°	135°
50	22.7	31.9	39.7	47.2	54.8	62.7	70.4	77.2	82.1
63	24.2	34.2	42.6	50.6	58.7	66.9	74.8	81.6	86.4

Proximity Switch Specifications

Manufacturer	TURCK	P&F
Power supply voltage	10 to 30 VDC	10 to 30 VDC
Output	N.O., PNP	N.O., PNP
Continuous load current	150 mA	100 mA
Response frequency	30 Hz	25 Hz
Housing material	PBT	PA6, PBT
Output indication	Clamping side: Red Unclamping side: Yellow	Clamping side: Red Unclamping side: Yellow
Voltage indication	Green	Green
Connector	M12 connector	M12 connector

* Switch specifications correspond to the manufacturers' technical information.

Wiring Diagram (PNP Connection Circuit)

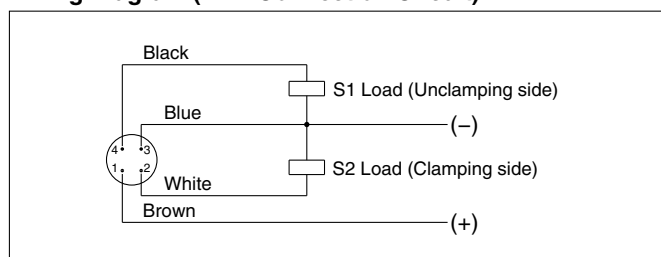

* Applicable to both TURCK and P&F.

* Please contact SMC for NPN specifications.

Replacement Parts

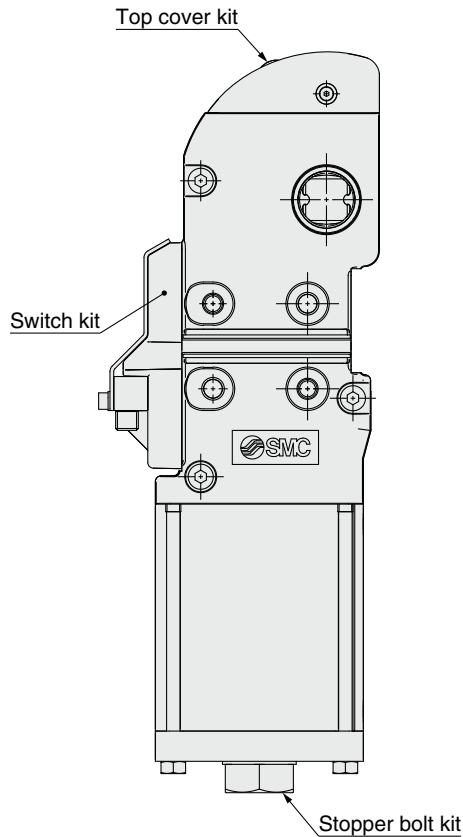

Switch Kit No. (with Metal Switch Cassette Cover)

CKZ3N - S 050 T - X2734

Bore size		Proximity switch	
050	ø50 equivalent	T	TURCK
063	ø63 equivalent	P	P&F
		W	None

* The switch kit includes a switch cassette assembly, metal switch cassette cover, and mounting brackets.

Top Cover Kit No.

Rubber cover

CKZ2N - T 050

Bore size	
050	ø50 equivalent
063	ø63 equivalent

Metal cover

CKZ3N - T 050 M

Bore size	
050	ø50 equivalent
063	ø63 equivalent

* The top cover kit includes a top cover and mounting brackets.

* Refer to page 12 for procedures for changing the stopper bolt and switch positions and for top cover replacement instructions.

Stopper Bolt Kit No.

CKZ3N - B 050 D

Bore size		Arm opening angle	
050	ø50 equivalent	J	15°
063	ø63 equivalent	H	30°
		G	45°
		F	60°
		E	75°
		D	90°
		C	105°
		B	120°
		A	135°

* The stopper bolt kit includes a stopper bolt and mounting brackets.

Dimensions

CKZ3T-X2734

Rubber cover type

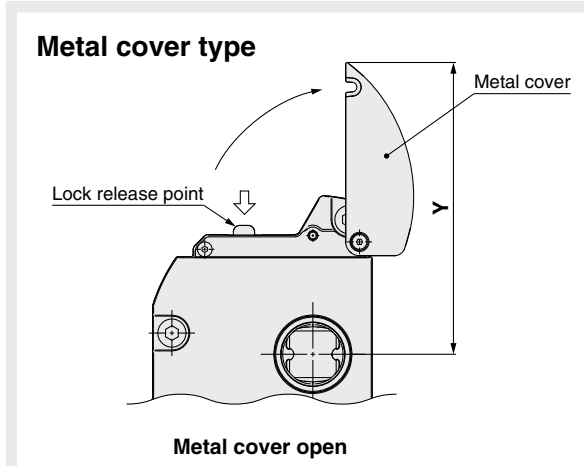
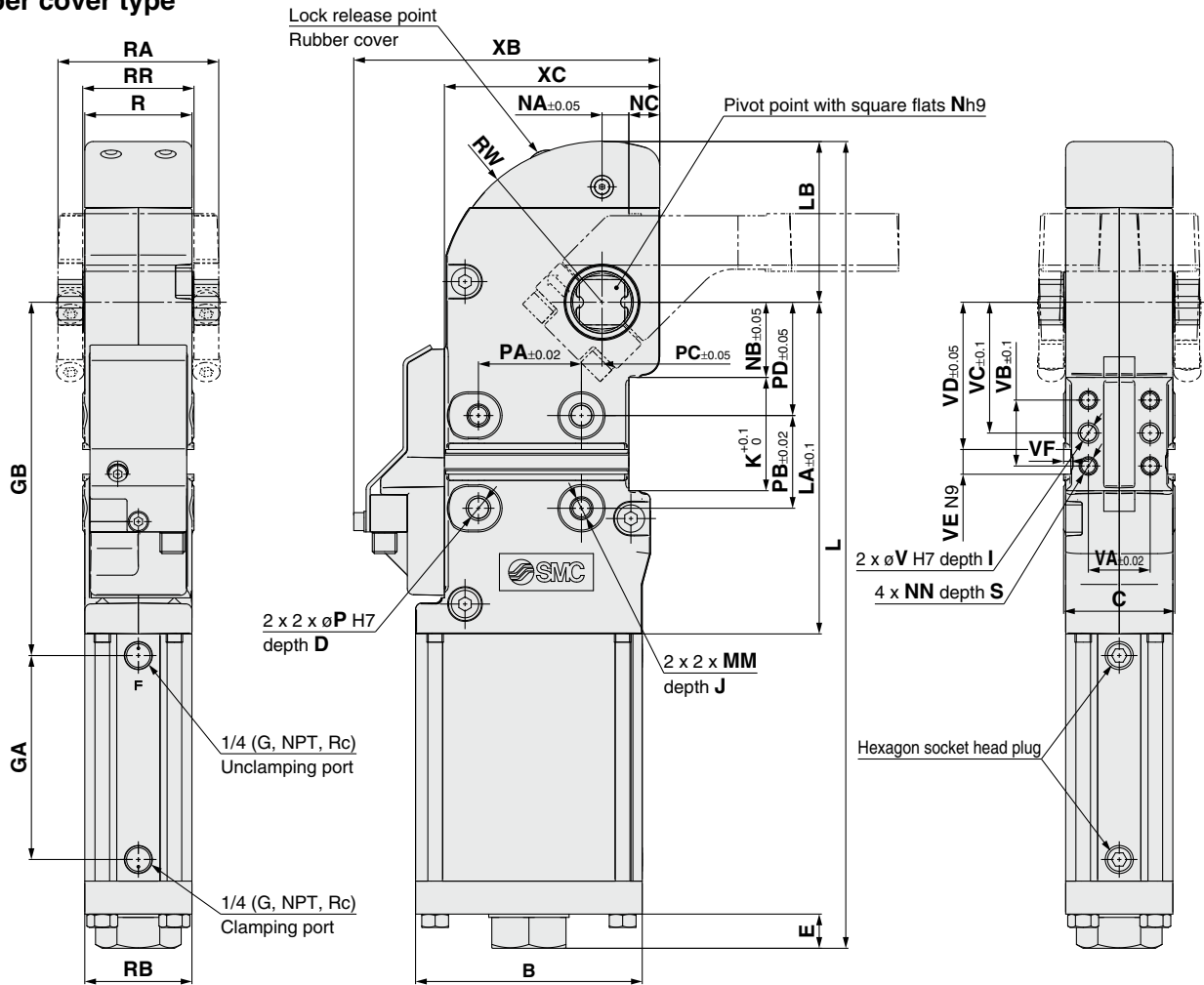

[mm]

Bore size	B	C	D	E	GA	GB	I	J	K	L	LA	LB		MM	N	NA	NB	NC	NN
												Rubber cover	Metal cover						
50	92	48	12	13.7	95	166	10	12	55	376.6	155.5	78.4	78.4	M10 x 1.5	19	13	36.5	9.5	M8 x 1.25
63	110	54	12	16.6	99	171.5	10	12	55	391.6	161	78	78.4	M10 x 1.5	22	13	36.5	15	M8 x 1.25

Bore size	P	PA	PB	PC	PD	R	RA	RB	RR	S	V	VA	VB	VC	VD	VE	VF	W	XB	XC	Y
50	10	50	45	10	55	46	68	46	48	11	8	30	32	63.5	71.5	12	3.5	78.4	136	92	132
63	10	50	45	10	55	52	78	52	54	11	8	30	32	63.5	71.5	12	3.5	78	148.5	104.5	138

Dimensions: With Manually Operated Handle

CKZ3T-X2568^L_R

* Refer to the CKZ3T-X2734 (page 4) for dimensions other than those shown below.

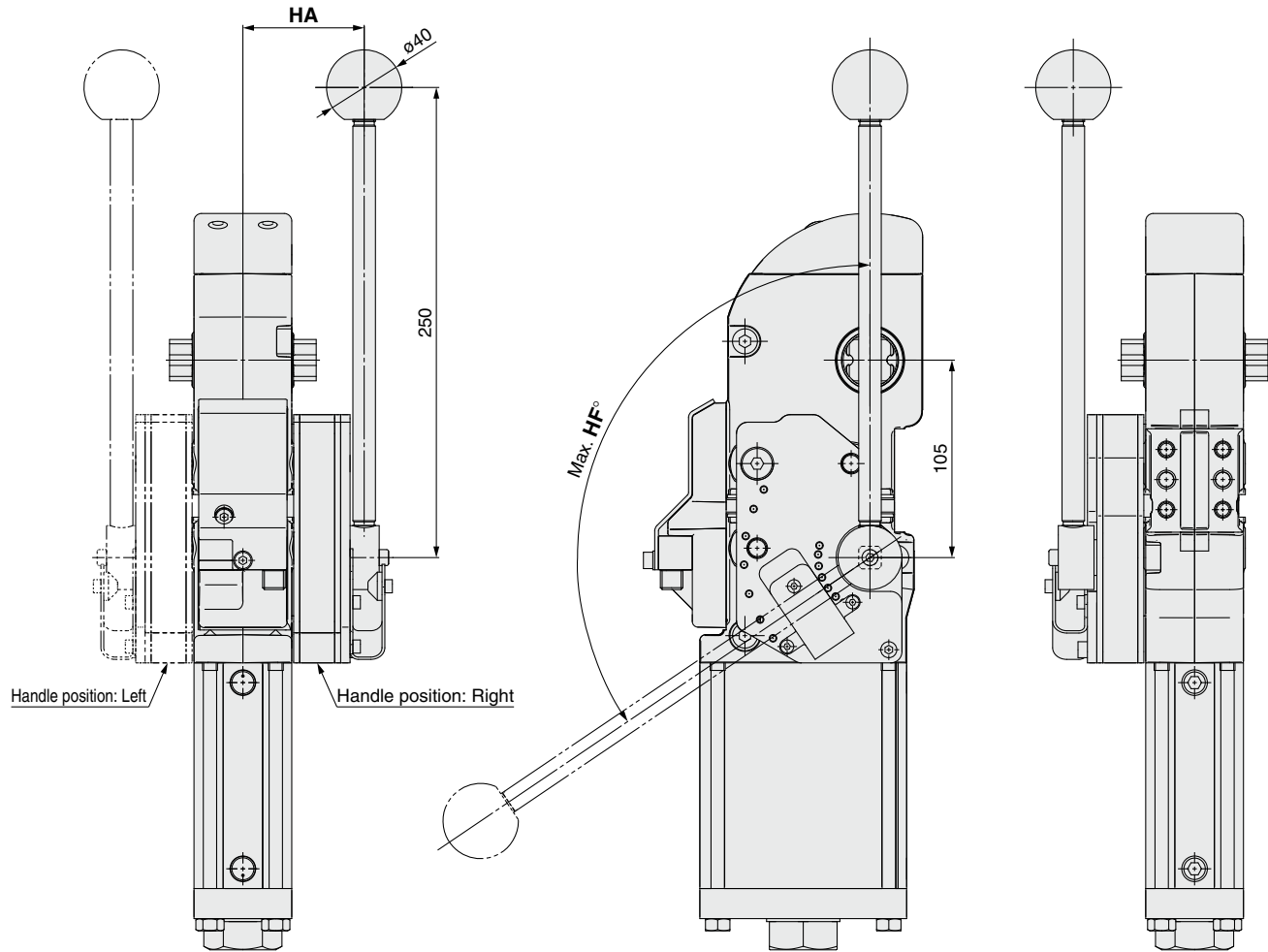

[mm]	
Bore size	HA
50	61.5
63	64.5

[mm]		
Bore size	Arm opening angle [°]	HF°
50	15	36
	30	49
	45	61
	60	73
	75	87
	90	101
	105	114
63	120	124
	15	41
	30	55
	45	68
	60	81
	75	94
	90	107
	105	117
	120	124

Dimensions: Clamp Arm **Bore Size 50**

Offset 15 mm

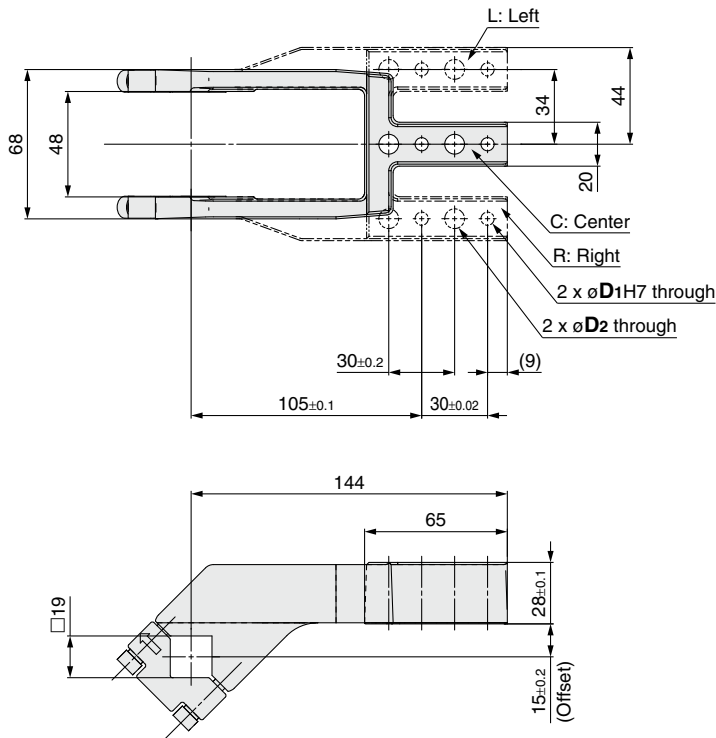

Model	D ₁	D ₂	Weight [kg]
CKZT50-A015CS	6	9	0.8
CKZT50-A015CB	8	10.2	0.8
CKZT50-A015RS	6	9	0.9
CKZT50-A015RB	8	10.2	0.9
CKZT50-A015LS	6	9	0.9
CKZT50-A015LB	8	10.2	0.9

Offset 45 mm

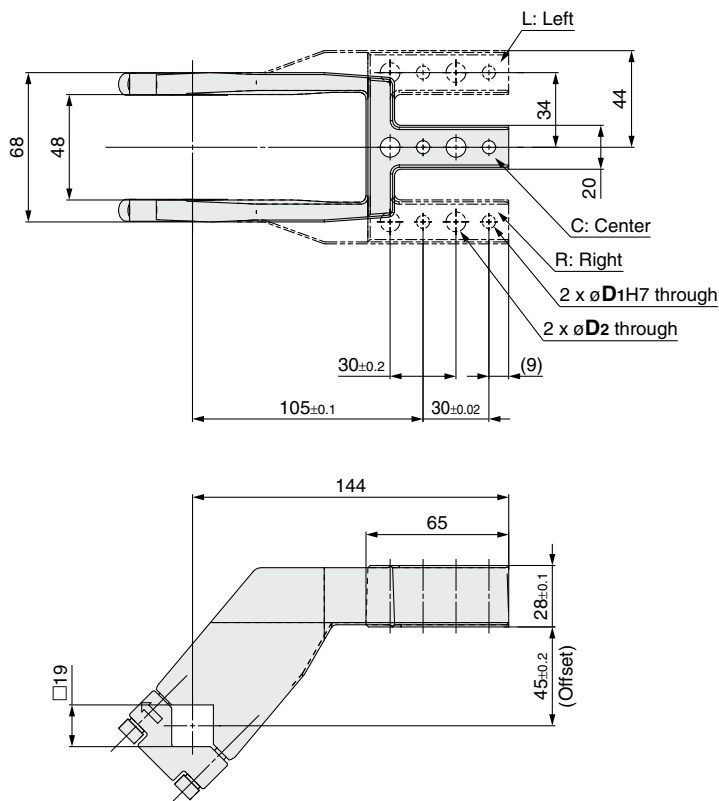

Model	D ₁	D ₂	Weight [kg]
CKZT50-A045CS	6	9	0.9
CKZT50-A045CB	8	10.2	0.9
CKZT50-A045RS	6	9	1.0
CKZT50-A045RB	8	10.2	1.0
CKZT50-A045LS	6	9	1.0
CKZT50-A045LB	8	10.2	1.0

Dimensions: Clamp Arm **Bore Size 63**

Offset 15 mm

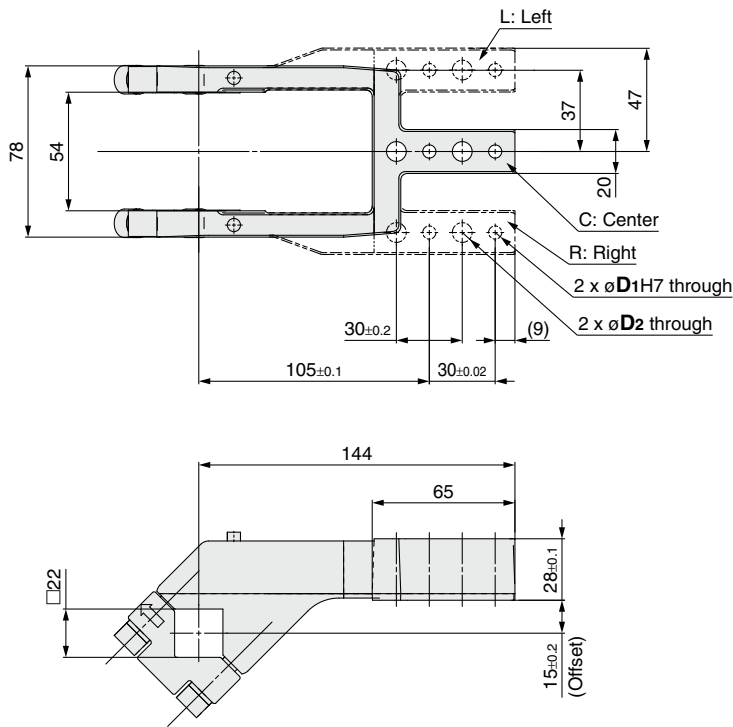

Model	D1	D2	Weight [kg]
CKZT63-A015CS	6	9	1.0
CKZT63-A015CB	8	10.2	1.0
CKZT63-A015RS	6	9	1.1
CKZT63-A015RB	8	10.2	1.1
CKZT63-A015LS	6	9	1.1
CKZT63-A015LB	8	10.2	1.1

Offset 45 mm

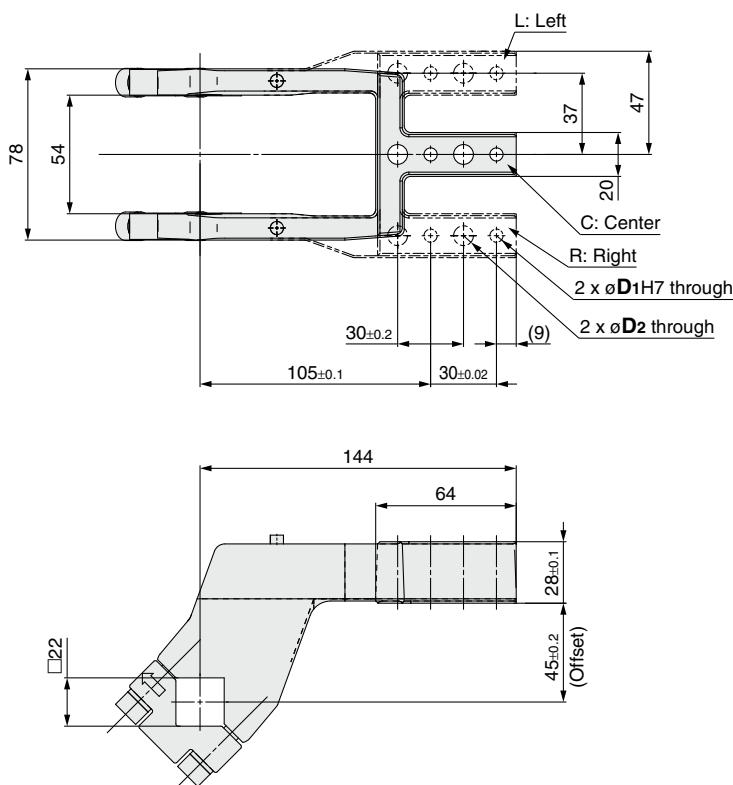

Model	D1	D2	Weight [kg]
CKZT63-A045CS	6	9	1.2
CKZT63-A045CB	8	10.2	1.2
CKZT63-A045RS	6	9	1.3
CKZT63-A045RB	8	10.2	1.2
CKZT63-A045LS	6	9	1.3
CKZT63-A045LB	8	10.2	1.2

Model Selection

Relation between arm length and clamping force

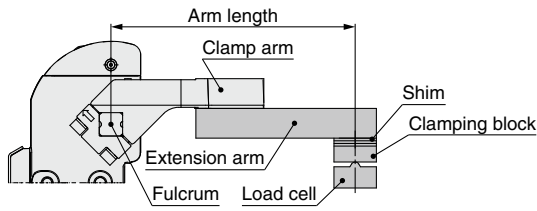

Bore Size: 50

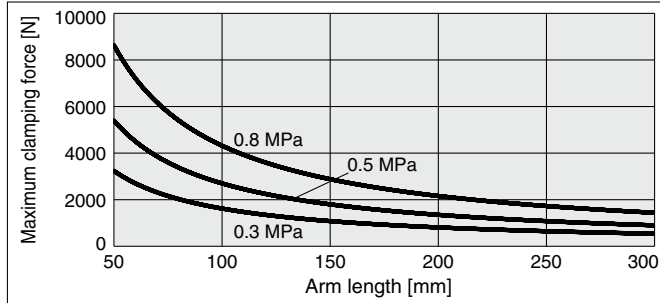

Bore Size: 63

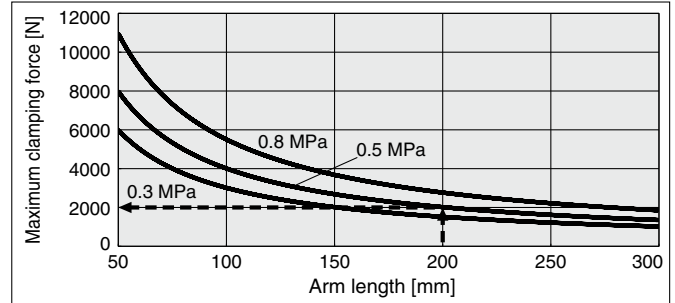

Calculation example Bore size: 63, Arm length: 200 mm, Operating pressure: 0.5 MPa

With an arm length of 200 mm and an operating pressure of 0.5 MPa, according to the graph, the maximum clamping force is 2000 N.

Allowable arm length

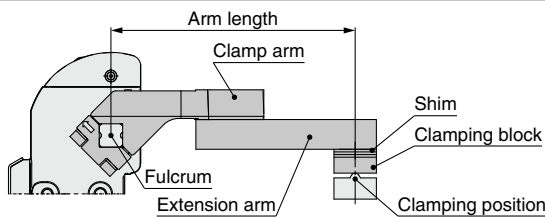

Bore size	Allowable arm length [mm]
50	300
63	300

Allowable load mass

The allowable load mass changes depending on the arm opening angle. Be sure to use the product within the allowable values shown in the graphs below.
 * The load indicates the total weight of the clamp arm, allowable arm and clamping block.
 * When the operating time is 1 second

Calculation procedure for allowable load mass

1. Calculate the distance L from the fulcrum to the load center of gravity.
2. Check the arm opening angle of the product.
3. Read the allowable load mass from the graph.

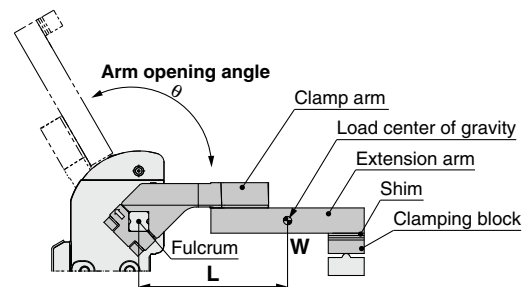

Bore Size: 50

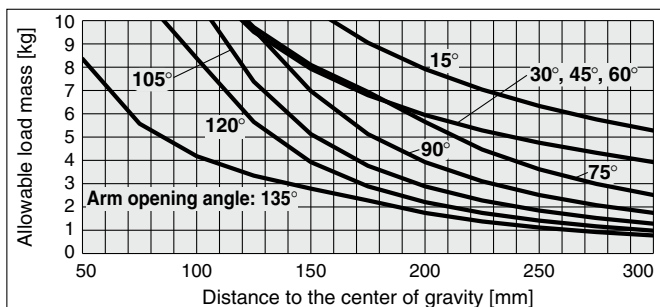

Bore Size: 63

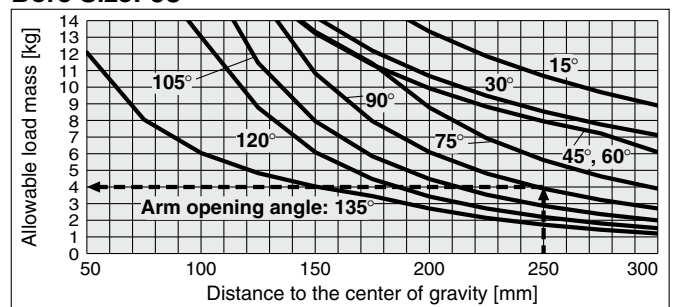

Calculation example Bore size: 63, Arm opening angle: 90°, Distance to the center of gravity L: 250 mm

With an arm opening angle of 90° and a 250 mm distance to the center of gravity, according to the graph, the maximum allowable load mass is 4.0 kg.

Setup Procedure

Precautions

- 1) The tightening torque of the clamp arm is 12 to 15 N·m for $\phi 50$ and 15 to 20 N·m for $\phi 63$. Refer to pages 6 and 7 for details on the clamp arm.
- 2) There is a mechanical difference of 0 to $+0.5^\circ$ at the clamping end as shown in Figure 1. Be sure to make adjustments externally using a shim. Refer to page 11.
- 3) Be sure to use a speed controller, and make adjustments according to the following conditions.

Unclamping to clamping: 1 second or more

Clamping to unclamping: 1 second or more

If excessive kinetic energy is applied, there is a possibility of damage.

- 4) When using a side guide: Attach the side guide so that lateral loads, such as galling, etc., are not applied to the clamp arm.

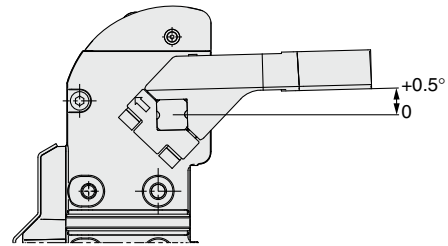
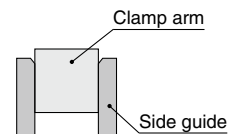
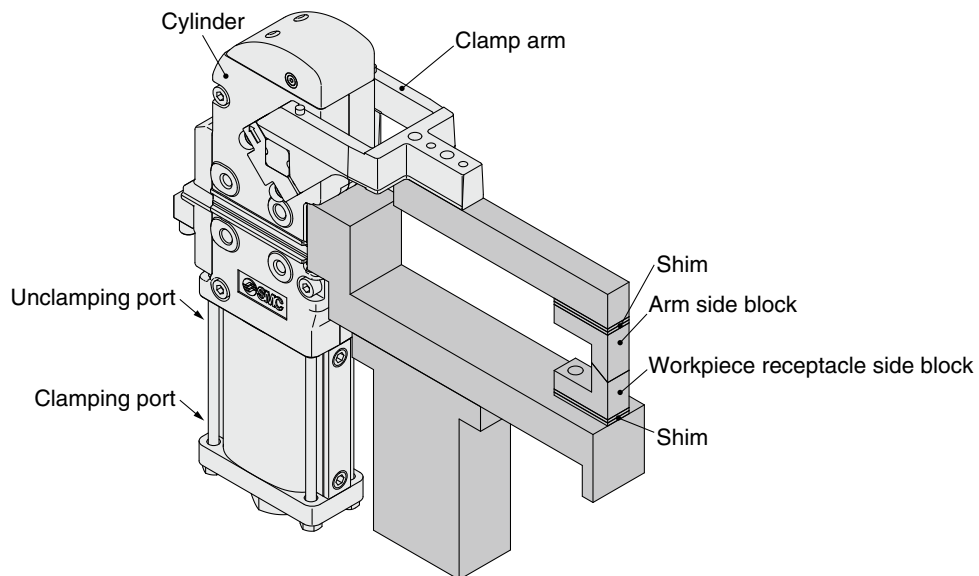

Figure 1



Power clamp cylinder mounting and setup procedure

<Ex. 1 When using clamping force only: When equipped with a workpiece receptacle>



Procedure

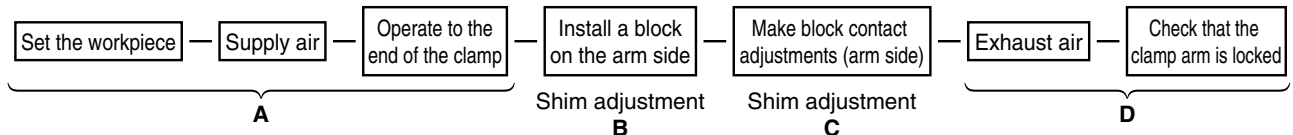

- A) Place the workpiece, supply air to the clamping port without attaching the block on the arm side, and operate the clamp arm to the end of the clamp.
- B) In the state of A), attach the workpiece and the arm side block, and adjust the shim so that there is a space of about 0 mm. During this step, theoretically, there is no clamping force pressing down on the workpiece.
- C) In order to generate a clamping force from the state described in step B), insert an additional shim. The thickness of the shim changes depending on the arm length and the operating pressure. Refer to page 11. Please note that the graph should only be used as a guide as there is a tolerance of about 10% in the clamp cylinder body.
- D) Exhaust the air while in the clamped state, and confirm that the clamp arm does not open.

Power clamp cylinder mounting and setup procedure

<Ex. 2 When using a hard stop: When not equipped with a workpiece receptacle>

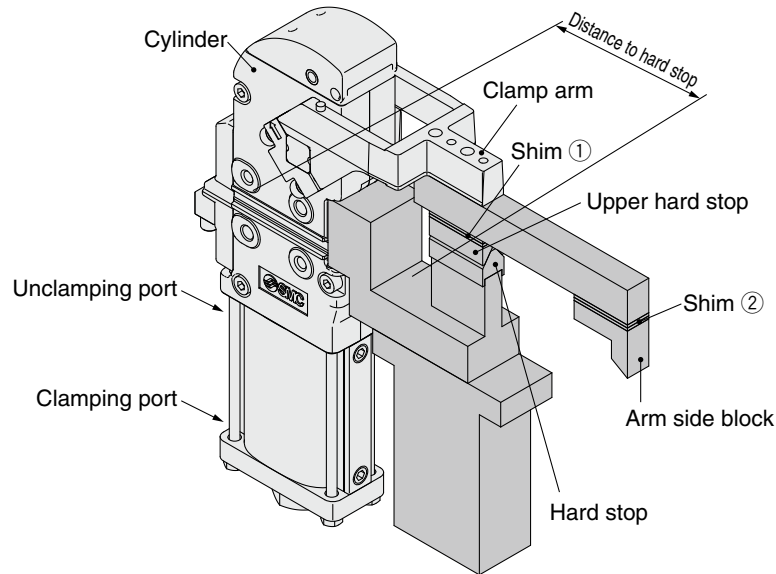

Procedure

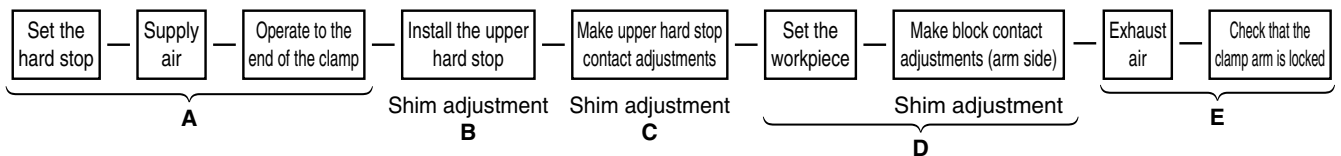

- A) Supply air to the clamping port without installing the upper hard stop, and operate the clamp arm to the end of the clamp.
- B) In the state of A), attach the upper hard stop and adjust shim ① so that there is a space of about 0 mm between the upper hard stop and the hard stop.
 During this step, theoretically, there is no clamping force applied to the hard stop.
- C) In order to generate a clamping force from the state described in step B), insert an additional shim.
 The thickness of the shim changes depending on the distance to the hard stop and the operating pressure. Refer to page 11, and consider the distance to the hard stop as the arm length.
 Please note that the graph should only be used as a guide as there is a tolerance of about 10% in the clamp cylinder body.
- D) In the state of C), adjust shim ② so that the arm side block contacts the workpiece.
- E) Exhaust the air while in the clamped state, and confirm that the clamp arm does not open.

Relation between shim thickness and clamping force

- * Use this figure as a guide as there is a tolerance of about 10% in the clamp cylinder body.
- * When a shim exceeding the peak clamping force position on the graph is inserted, the lock will not be activated when clamped. Insert a shim of the appropriate thickness.
- * The arm length indicates the distance between the clamp arm shaft and the clamping position.
For distance "A" between the knock positioning pinhole and the clamp arm shaft, refer to Table 1.

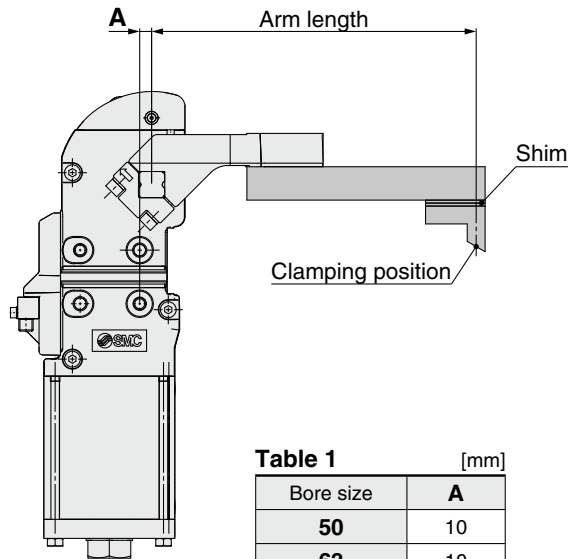
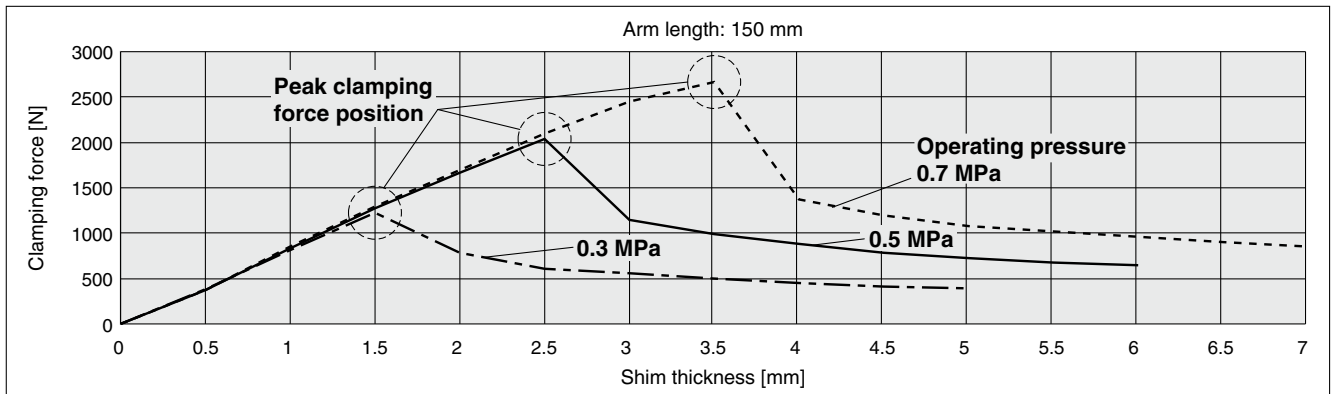

Table 1 [mm]

Bore size	A
50	10
63	10

Bore Size: 50



Bore Size: 63

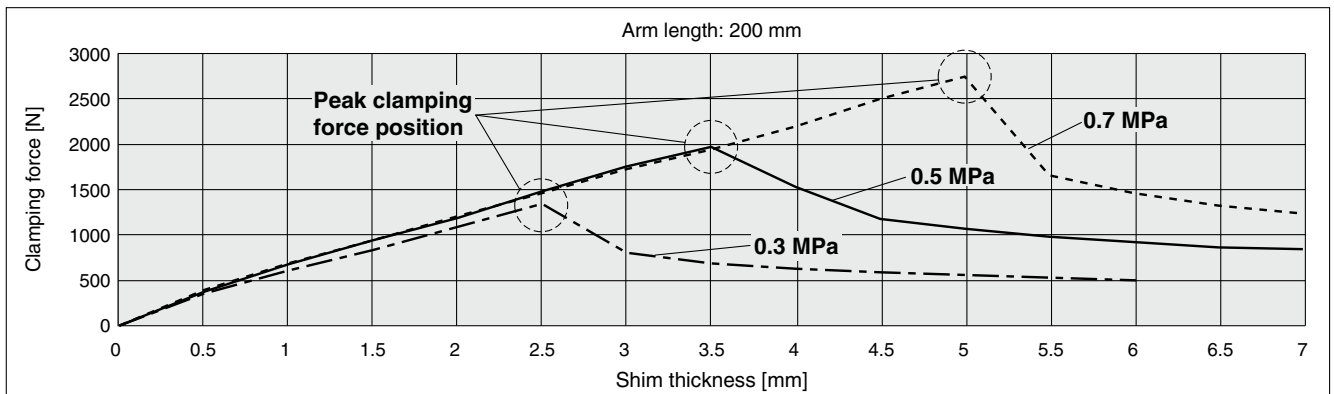

To change the arm opening angle

⚠ Caution Be sure to confirm safety, and perform the work while the air is exhausted.

1 Procedure for changing the stopper bolt position

- 1) Remove the stopper bolt of the head cover, and replace with a stopper bolt for the desired angle using the tightening torque below. When tightening the stopper bolt, hold the head cover.
Refer to Replacement Parts (page 3) for the part numbers of the applicable stopper bolts.

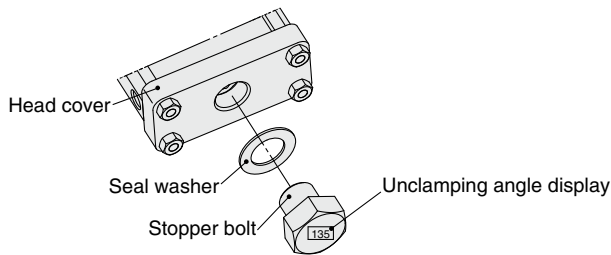

Stopper Bolt Tightening Torque

Bore size	Tightening torque [N·m]
50	45 to 65
63	85 to 115

2 Procedure for changing the switch position

- 1) Loosen the switch cassette mounting bolt, and remove the switch cassette.
- 2) Remove the switch on the unclamping side, and attach it in the position of the desired angle. Store the lead wire in the storage space.
- 3) Mount the switch cassette to the body, and tighten the switch cassette mounting bolt to the tightening torque shown below.
Refer to Replacement Parts (page 3) for the part numbers of the switch cassette replacement parts.

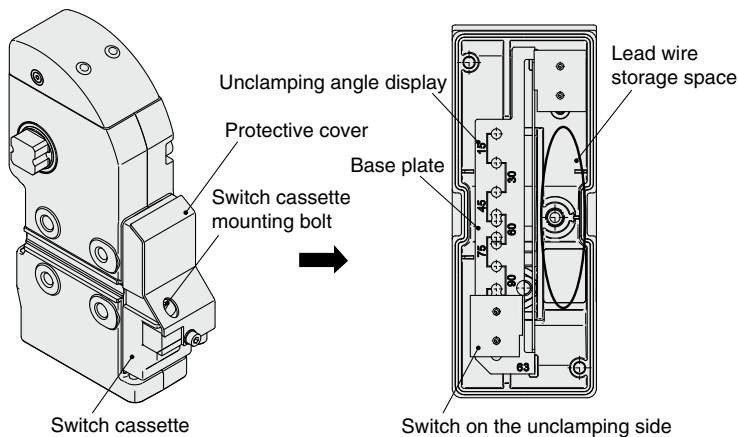

Switch Cassette Mounting Bolt Tightening Torque

Bore size	Tightening torque [N·m]
50	2.6 to 3.5
63	2.6 to 3.5

Top cover replacement

⚠ Caution Be sure to confirm safety, and perform the work while the air is exhausted.

- 1) Mount the top cover to the clamp cylinder, then tighten it to the specified tightening torque below.
- 2) It is possible to change from a rubber cover type to a metal cover type.
Refer to Replacement Parts (page 3) for the part numbers of the top cover replacement parts.

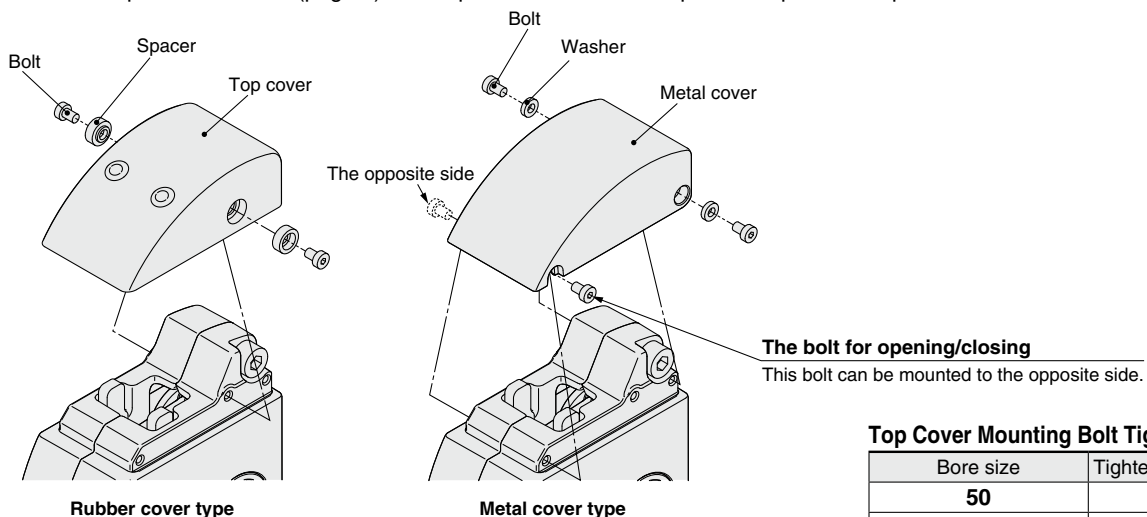

Top Cover Mounting Bolt Tightening Torque

Bore size	Tightening torque [N·m]
50	1.5 to 2.0
63	1.5 to 2.0



Specific Product Precautions

Be sure to read this before handling the products. For safety instructions and actuator precautions, refer to the “Handling Precautions for SMC Products” and the “Operation Manual” on the SMC website: <http://www.smcworld.com>

⚠ Caution

1. Manual lock release

Be sure to confirm safety before manually releasing the lock, and only perform work while **the air is exhausted**. Otherwise, the clamp arm may operate.

- In the case of a rubber cover, the lock can be released easily by hitting the round tab on the cover with a plastic hammer.
- In the case of a metal cover, the lock can be released easily by opening the cover and hitting the tab of the knuckle joint with a plastic hammer.

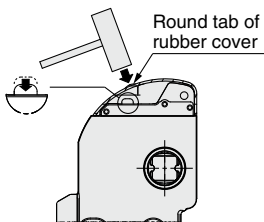

Rubber cover type

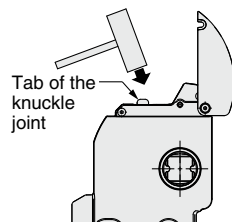

Metal cover type

- Provide enough space to perform a manual lock release.

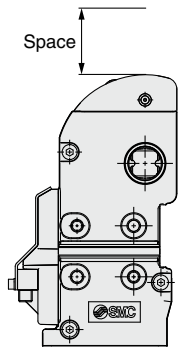

Rubber cover type

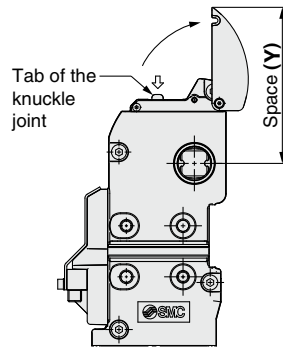

Metal cover type

[mm]	
Bore size	Y
50	132
63	138

⚠ Caution

2. Do not disassemble the power clamp cylinder.

The power clamp cylinder consists of a completely sealed structure in order to protect it from welding spatter. Do not disassemble, except for when replacing any of the replaceable parts, as the performance may deteriorate.

3. Vertical clamping

When mounting the clamp arm in a vertical clamping position, mount as shown in the figure below. The maximum arm opening angle is 105°. In the case of a metal cover type, select a 45 mm offset for the clamp arm. When a 15 mm offset is selected, the metal cover and clamp arm will interfere and the lock cannot be released manually.

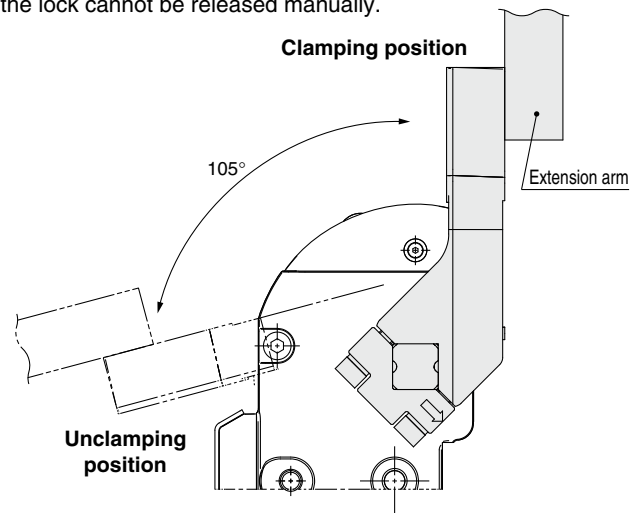

4. Proximity switch output

The switch output signal is output near the clamping end and the unclamping end respectively. The switch output signal on the clamping side does not output the status where the power clamp cylinder is locked by the toggle mechanism.

Power Clamp Cylinder Variations

Micro Clamp Cylinder/CKZM16-X2800/X2900



- Compact: Width 20 mm, Lightweight: 250 g
- Maximum clamping force: 200 N, Maximum holding force: 300 N
- Flat clamping characteristics
Outputs constant clamping force for workpiece thicknesses up to 3.5 mm
- Reduction of design/assembly labor by unitization
Arm assembly and mounting assembly have been added to the clamp cylinder.

Type	Series	Action	Bore size [mm]
Base type	CKZM16-X2800	Double acting	16
Tandem type	CKZM16-X2900	Double acting	16

Power Clamp Cylinder Compact Type/CKZT-X2797/X2798□

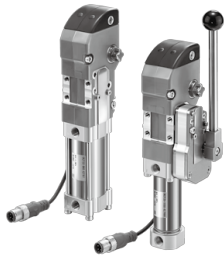

- Lightweight Weight: 580 g (ø25)
- Compact Width: 34 mm, Height: 192.4 mm (ø25, Arm opening angle: 90°)
- Clamping force: 1100 N (ø32, Arm length: 50 mm, 0.5 MPa pressure)
- Force amplification with a toggle mechanism and lock function
- Spatter-proof construction
- Equipped with a proximity switch that can be used in welding magnetic fields
- A model with a manually operated handle is available.

Series	Arm opening angle	Switch	Bore size [mm]
CKZT-X2797 Base type	90°, 105°	SENSTRONIC	25, 32
CKZT-X2798□ With manually operated handle	90°, 105°	SENSTRONIC	25, 32

NAAMS Standards Compliant Power Clamp Cylinder/CKZ3N-X2742A/X2568□

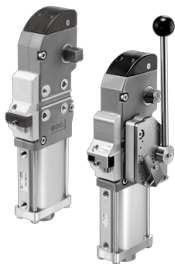

- Weight reduced by up to 38%
Aluminum body with greatly reduced weight
Suitable for robot material handling
- Simple switch adjustment greatly reduces work hours.
Switch can be adjusted easily when changing the arm opening angle.
- High clamping force 4000 N
- Metal switch cassette cover (Option)
Protects switch cassette from unexpected impact
- A model with a manually operated handle is available.

Series	Arm opening angle	Switch	Bore size [mm]
CKZ3N-X2742A Base type	15°, 30°, 45°, 60°, 75° 90°, 105°, 120°, 135°	TURCK/P&F	50, 63
CKZ3N-X2568□ With manually operated handle	15°, 30°, 45°, 60°, 75° 90°, 105°, 120°, 135°	TURCK/P&F	50, 63

Power Clamp Cylinder/CKZT



- 3 types of arm variations for each size
- Spatter-resistant and water-resistant structure

Series	Arm opening angle	Switch	Bore size [mm]
CKZT	30°, 45°, 60°, 75°, 90° 105°, 120°, 135°	TURCK/P&F	40, 50, 63, 80

Power Clamp Cylinder/CKZ2N



- Complies with the new NAAMS Standards (North America Automotive Metric Standard)
- 138 types of arm variations
- Spatter-resistant and water-resistant structure

Series	Arm opening angle	Switch	Bore size [mm]
CKZ2N	30°, 45°, 60°, 75°, 90° 105°, 120°, 135°	TURCK/P&F	50, 63, 80

* For detailed dimensions and specifications, refer to the **Web Catalog**.

 **Safety Instructions** Be sure to read the "Handling Precautions for SMC Products" (M-E03-3) and "Operation Manual" before use.