

# Circulating Fluid Temperature Controller

**New**

# Thermo-chiller **Compact Dual/Basic Type for Lasers**

Air-cooled Refrigeration

Water-cooled Refrigeration



Scheduled to acquire UL Standards (Only 400 V)

**New** A 5 kW cooling capacity specification (HRLE050) has been added.

**RoHS**

With functions narrowed down, **2 independent temperature control systems** have been achieved with only **a single compressor**, **a single pump**, and **a single tank**.

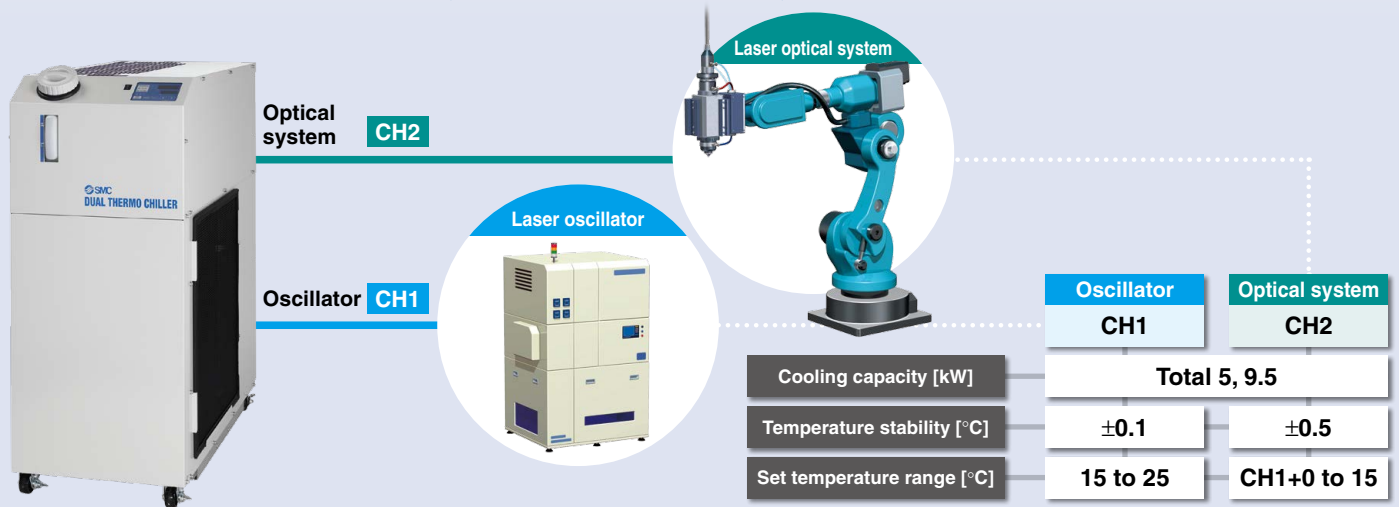

**Space saving** Footprint **reduced by 21%**

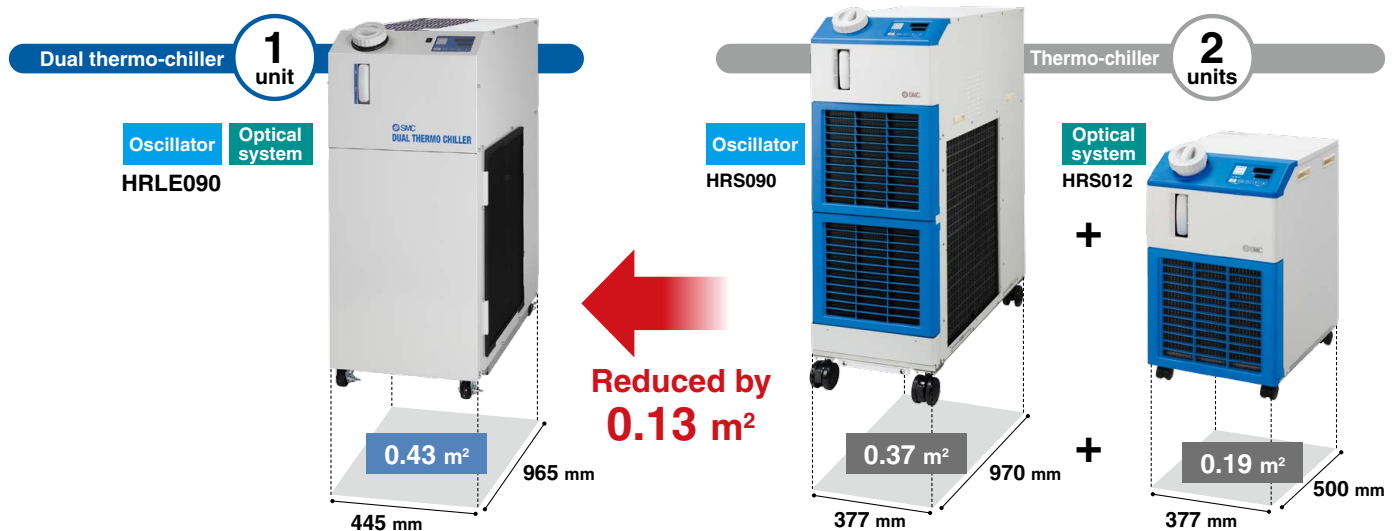

**Energy saving** Power consumption **reduced by 17%**

Globally compatible power supplies

	50 Hz	60 Hz	50/60 Hz
3-phase 200 VAC	●		
3-phase 200 to 230 VAC		●	
3-phase 380 to 415 VAC		●	●
3-phase 460 to 480 VAC		●	
Single-phase 200 to 230 VAC			★

● : HRLE090   ★ : **New** HRLE050

**HRLE Series**



CAT.ES40-75A <sup>Ⓐ</sup>

### Space saving

The temperatures of 2 fluid channel systems can be controlled individually. Compact

Series	Height	Width	Depth
HRLE090	1055	445	965
HRS090	1080	377	970

[mm]



### Reduced wiring/labor

One power supply system for temperature control of 2 channels  
Less work-hour for wiring

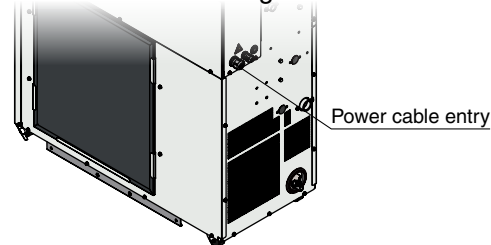

### Energy saving

#### Power consumption reduced by 17%

- 1 compressor, fan, and pump
- Uses a heating method that does not require a heater

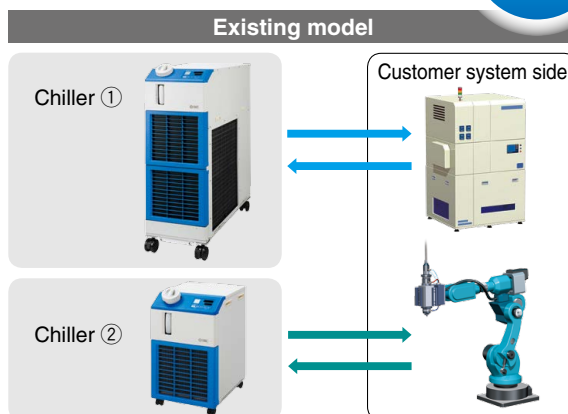
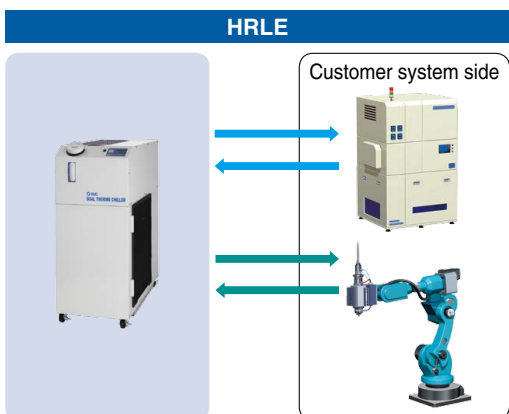
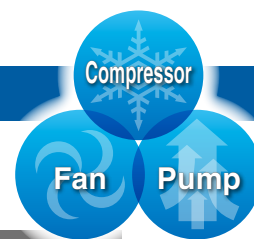

- Conditions**
- Outdoor air temperature: 32°C
  - Circulating fluid set temperature: 20°C/25°C (CH1/CH2)
  - Heat load in the customer equipment: 9.5 kW (CH1, 2 total)
  - Power supply: 200 V 60 Hz
  - Circulating fluid flow rate: 35 LPM/2 LPM (CH1/CH2) to the customer equipment
  - External piping: The shortest distance assumed to the customer equipment

#### Circulating fluid can be heated without a heater.

(Circulates the hot discharged gas through expansion valve B)

Hot discharge gas is recycled for heating.  
Energy saving by heaterless heating function

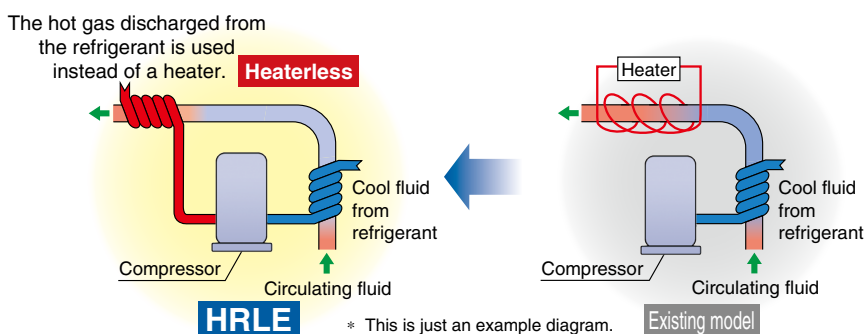

### Variations

	Cooling capacity [kw]*1	Temperature stability [°C]		Set temperature range [°C]		Options <b>p. 19</b>	Accessories (Sold separately)
		CH1	CH2	CH1	CH2		
<b>Air-cooled refrigeration</b> pp. 9, 10	8.0/9.5	±0.1	±0.5	15 to 25	CH1 temperature + 0 to 15	• Increased cooling capacity function (With inverter for compressor) • Circulating fluid pressure adjustment function (With inverter for pump) • Deionized water (Pure water) piping	• G/NPT thread conversion fitting set • Bypass piping • Electric conductivity control (DI filter + Solenoid valve for control) • Particle filter • Automatic fluid fill set • Ball valve set (With pressure gauge)
<b>Water-cooled refrigeration</b> pp. 11, 12	9.5/11.0						

\*1 CH1, 2 total, 50/60 Hz

## One compressor controls 2 channels.

Temperature of **CH1: Oscillator** and **CH2: Optical system** is controlled individually.

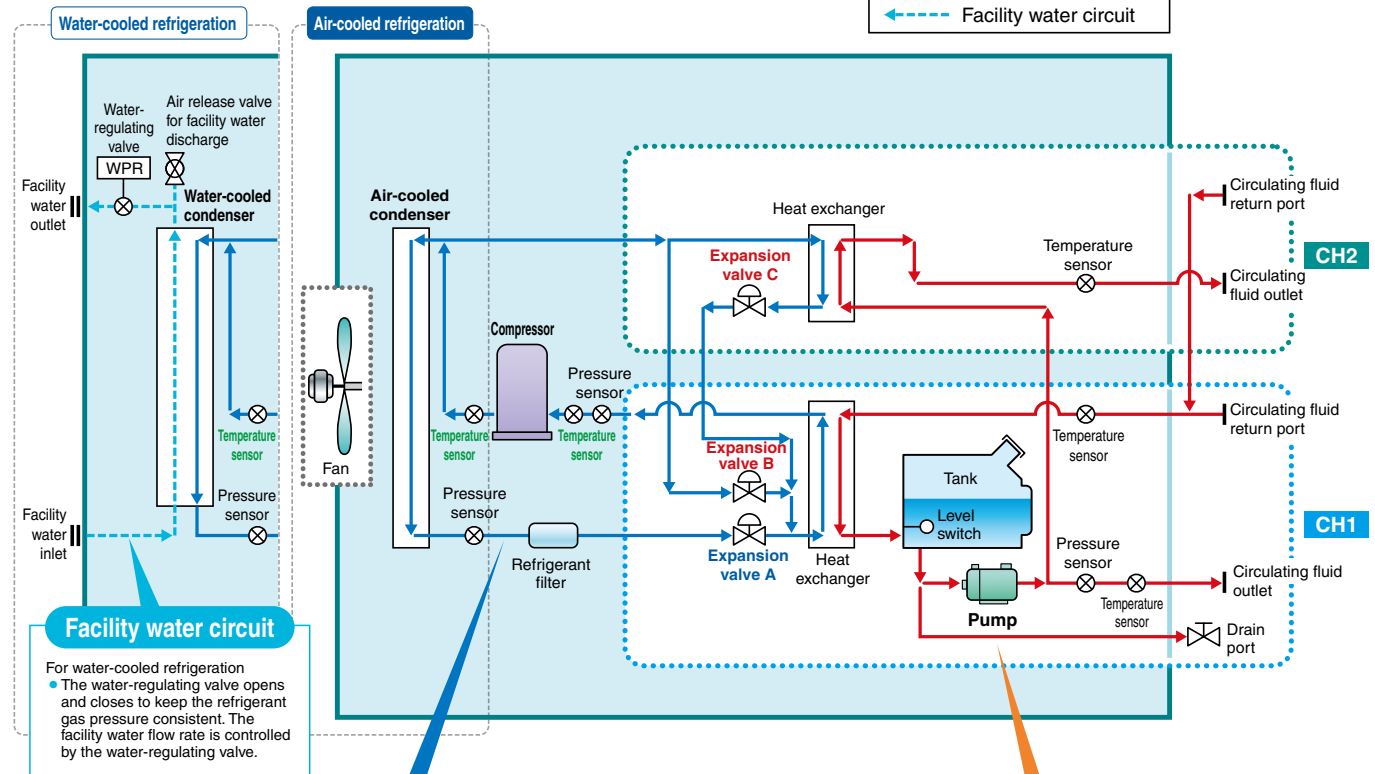

**Facility water circuit**  
For water-cooled refrigeration  
• The water-regulating valve opens and closes to keep the refrigerant gas pressure consistent. The facility water flow rate is controlled by the water-regulating valve.

**Refrigeration circuit**

- The compressor compresses the refrigerant gas and discharges high-temperature, high-pressure refrigerant gas.
- In the case of air-cooled refrigeration, the high-temperature, high-pressure refrigerant gas is cooled down by fan ventilation in the air-cooled condenser, where it is then liquefied.
- The liquefied high-pressure refrigerant gas expands and its temperature lowers when it passes through expansion valve A, where it vaporizes after receiving heat from the circulating fluid in the evaporator.
- The vaporized refrigerant gas is sucked into the compressor and compressed again.
- When heating the circulating fluid, the high-pressure, high-temperature refrigerant gas is bypassed into the evaporator by expansion valves B and C to heat the circulating fluid.
- In the case of water-cooled refrigeration, the refrigerant gas is cooled by the facility water in the facility water circuit in the water-cooled condenser, where it is then liquefied.

**POINT** The combination of the precise control of expansion valves A, B, and C realizes energy saving operation without waste and high temperature stability.

**POINT** One compressor controls 2 channels which realize the independent temperature control of 2 systems.

**Circulating fluid circuit**

- After the circulating fluid discharged from the pump is heated or cooled by the customer system side, it returns to the tank.
- The circulating fluid is sent to the heat exchanger by the pump, and is controlled to a set temperature by the refrigeration circuit, to be discharged to the customer system side again by the thermo-chiller.

**POINT** Adjusting the discharge pressure by pump inverter control eliminates wasteful discharge of the circulating fluid and realizes energy saving operation.

**POINT** Since the refrigeration circuit is controlled by the signals from 2 temperature sensors (for return and discharge), precise temperature control of the circulating fluid can be achieved. Therefore, there is no need for a tank with a large capacity to absorb the circulating fluid temperature difference, as high temperature stability can be achieved even with a small-size tank. This also contributes to space saving.

\* When the inverter option is equipped

## Temperature stability: $\pm 0.1^\circ\text{C}$ (CH1) When a load is stable

By controlling the inverter fan and electronic expansion valve simultaneously, it maintains the good temperature stability when the heat load fluctuates.

\* For HRLE090-A-20

- Conditions**
- Outdoor air temperature:  $32^\circ\text{C}$
  - Circulating fluid set temperature:  $20^\circ\text{C}/25^\circ\text{C}$  (CH1/CH2)
  - Heat load in the customer equipment: 9.5 kW (CH1, 2 total)
  - Power supply: 200 V 60 Hz
  - Circulating fluid flow rate: 35 LPM/2 LPM (CH1/CH2) 60 Hz
  - External piping: Bypass piping + Heat load

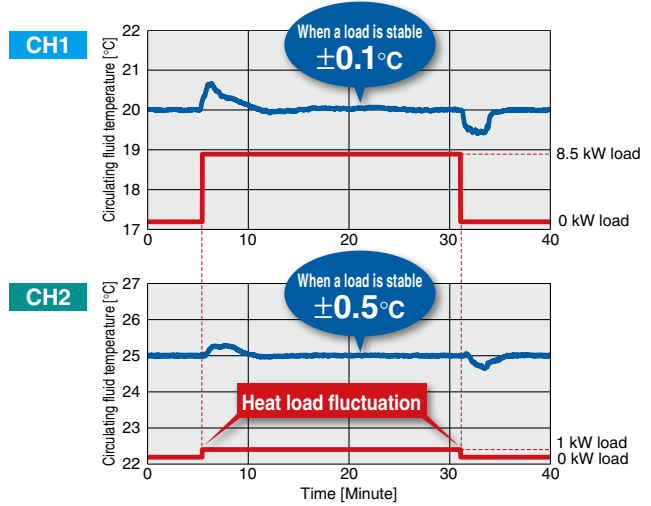

### Electric conductivity control set (With DI filter + Solenoid valve kit for control) p. 21

The electric conductivity of the circulating fluid can be set with the controller monitor arbitrarily.

Set control range:  
0.5 to 45.0  $\mu\text{S/cm}$

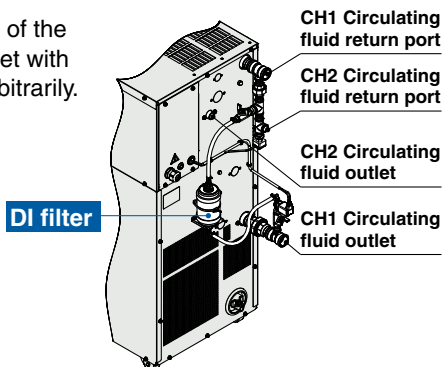

### Particle filter set p. 22

Removes foreign matter in the circulating fluid

Effective in preventing foreign matter from entering the customer equipment and chiller

- Prevents pump malfunction
- Prevents the water-cooled condenser performance from falling

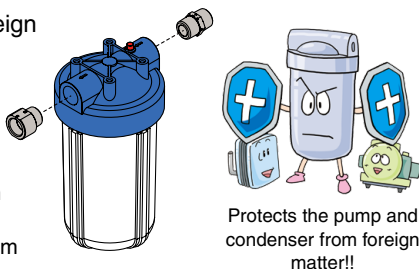

### Simple operation

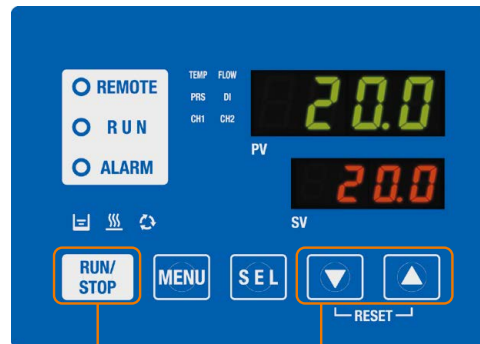

- Step 1 Press the **RUN/STOP** key.
- Step 2 Adjust the temperature setting with the **▼** / **▲** keys.
- Step 3 Press the **RUN/STOP** key to stop operation.
- Easy operation

#### Large digital display

The large digital display (7-segment and 4 digits) and 2-row display provide a clearer view of the current value (PV) and set value (SV).

### Protection of the electrical unit: IPX4

The board and electric parts are located inside the electrical box, where they can be protected from dust particles and water splashing.

Electrical box  
**IPX4**

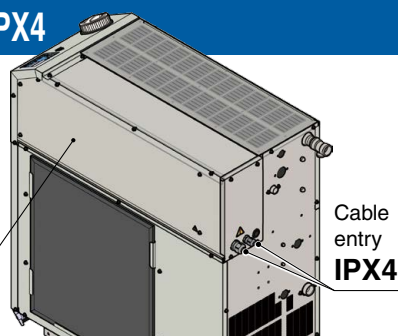

### Easy to check the circulating fluid level

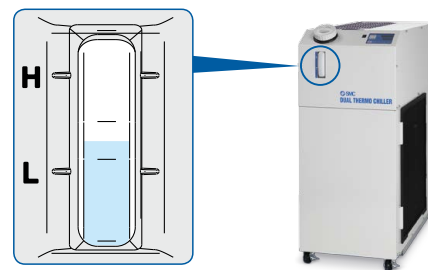

### Circulating fluid can be heated without a heater.

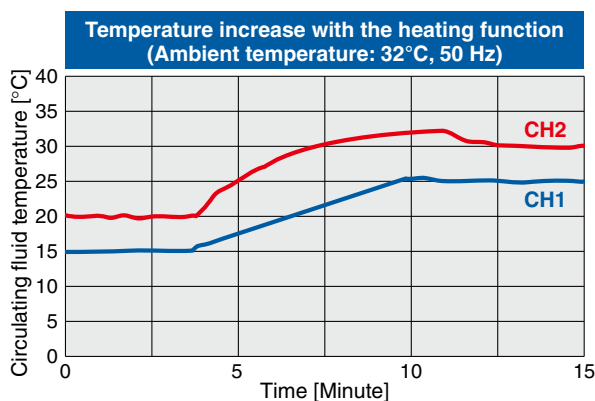

\* For HRLE090-A-20

- Conditions**
- Ambient temperature: 32°C
  - Power supply: 200 V 50 Hz
  - Circulating fluid flow rate: [CH1] 35 L/min at 0.5 MPa, [CH2] 2 L/min at 0.5 MPa
  - Circulating fluid temperature: [CH1] 15°C → 25°C, [CH2] CH1 + 5°C
  - External piping: Bypass piping

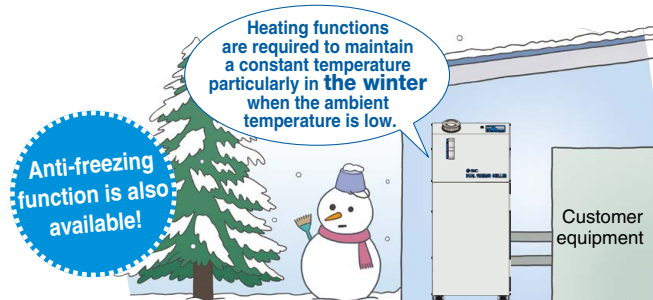
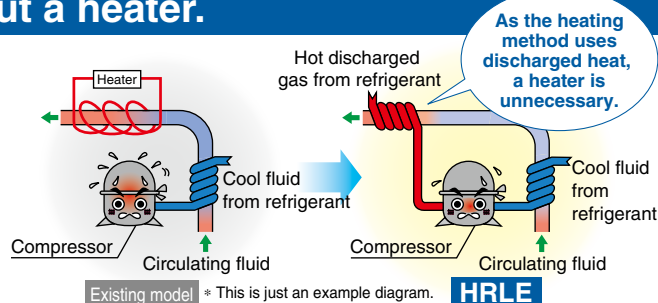

## Globally compatible power supplies

(Europe, Asia, Oceania, Central and South America)

No transformers required

**Power supply**

Applicable to 200 to 230 VAC,  
380 to 415 VAC, or 460 to 480 VAC

Transformers are not required even when used overseas.

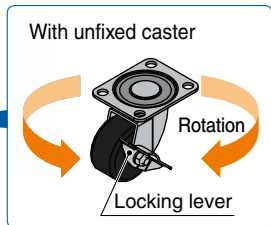
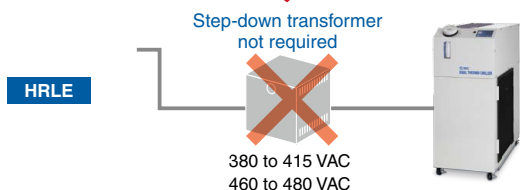
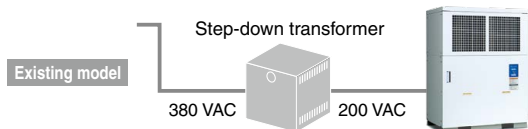

## Shaped for easy supply of circulating fluid

The angled supply port facilitates the easy supply of circulating fluid.

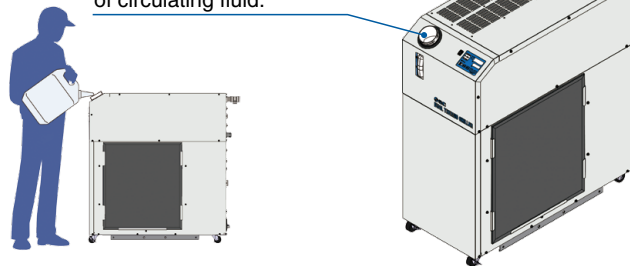

## Easy cleaning of the tank

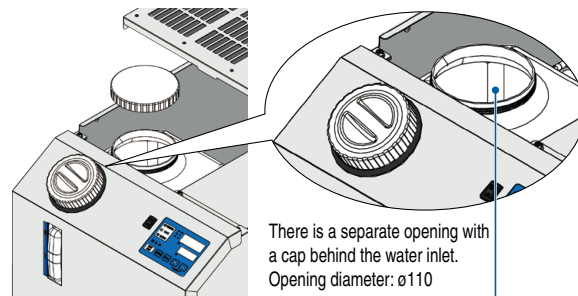

## Toolless inspection and cleaning of air-cooled condenser

\* For air-cooled refrigeration

### Dustproof filter

\* It can be removed with no tools.

Easy to remove dust, cutting chips, etc., stuck to the dustproof net with a brush or air blow

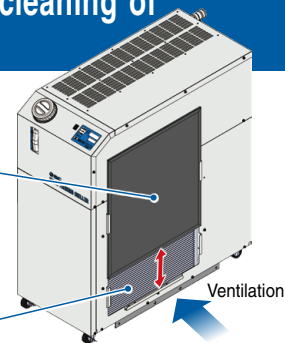

## Power supply (24 VDC) available

Power can be supplied from the terminal block on the rear side to external switches, etc.

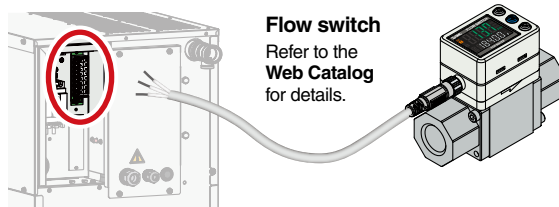

## Increased cooling capacity function (Option) \* HRLE090 only

The inverter for compressor increases the cooling capacity of the 50 Hz area to that of the 60 Hz area.

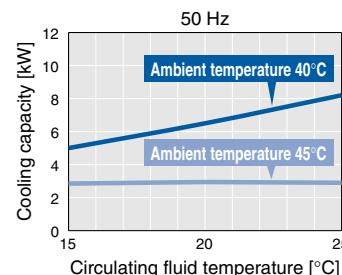
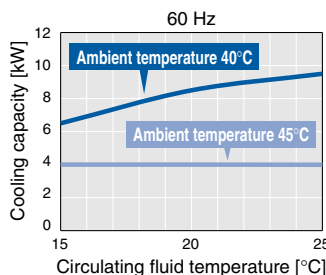

## Convenient functions (Refer to the Operation Manual for details.)

### ■ Anti-freezing operation function

If the circulating fluid approaches its freezing point, for example, on a cold winter night, the pump operates automatically, and the heat generated by the pump warms the circulating fluid, preventing freezing.

### ■ Function to output a signal for completion of preparation

Notifies by communication when the temperature reaches the pre-set temperature range

### ■ Key-lock function

Can be set in advance to protect the set values from being changed by pressing keys by mistake

## Self-diagnosis function and check display

### Display of individual alarm codes

For details, refer to page 17.

Operation is monitored at all times by the integrated sensor. Should any error occur, the self-diagnosis result is displayed by the applicable alarm code. This makes it easier to identify the cause of the alarm. Can be used before requesting service

### Changeable alarm set values

Setting item	Set range
Circulating fluid discharge pressure rise	0.3 to 0.6 MPa
Circulating fluid discharge pressure drop	0.05 to 0.6 MPa

#### Ex. AL01 "Low level in tank"

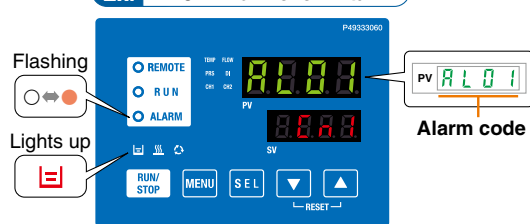

### Check display

The internal temperature, pressure, and operating time of the product are displayed.

#### Ex. RUN "Accumulated operating time of the thermo-chiller"

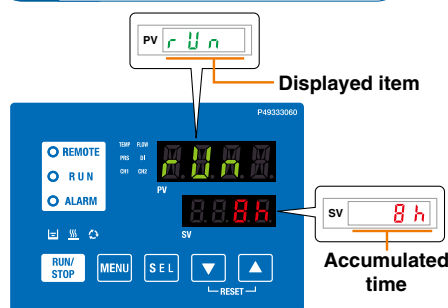

Displayed item
Circulating fluid outlet temperature
Circulating fluid return temperature
Compressor gas temperature
Circulating fluid outlet pressure
Compressor gas discharge pressure
Compressor gas return pressure
Accumulated operating time of the thermo-chiller
Accumulated operating time of the pump
Accumulated operating time of the fan*1
Accumulated operating time of the compressor
Accumulated operation time of the dustproof filter*1

\*1 These are displayed only for air-cooled refrigeration.

## Communication functions p. 18

Serial communication (RS485) and contact I/Os (2 inputs and 3 outputs) are equipped as standard.

This allows for communication with the customer equipment and system construction, depending on the application.

A 24 VDC output can be also provided and is available for use with flow switches (SMC's PF3W, etc.).

Communication cable



### Ex.1 Remote signal I/O through serial communication

Remote operation is enabled (to start and stop operation) through serial communication.

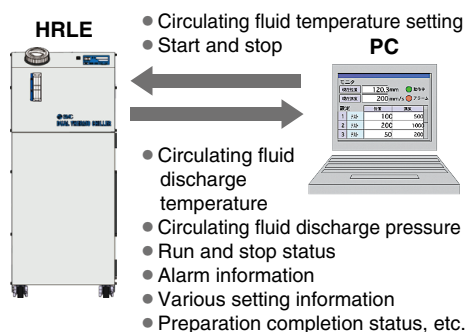

### Ex.2 Remote operation signal input

One of the contact inputs is used for remote operation and the other is used to monitor the flow of a flow switch. This is where their alarm outputs are taken in.

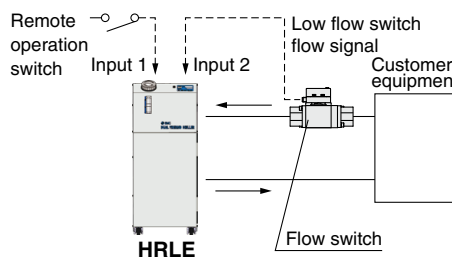

Power for flow switches (24 VDC) can be supplied by the thermo-chiller.

### Ex.3 Alarm and operation status (start, stop, etc.) signal output

The alarm and status generated in the product can be output.

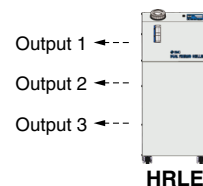

#### Output examples

- Output 1: Operation status (start, stop, etc.)
- Output 2: Alarm status signal
- Output 3: Preparation completion status signal

## Global Supply Network

**SMC has a comprehensive network in the global market.**

We now have a presence of more than 560 branch offices and distributors in 83 countries and regions worldwide, such as Asia, Oceania, North/Central/South America, and Europe. With this global network, we are able to provide a global supply of our substantial range of products and high-quality customer service. We also provide full support to local factories, foreign manufacturing companies, and Japanese companies in each country.



Air-cooled refrigeration



Water-cooled refrigeration

## SMC Thermo-chiller Variations

Lots of variations are available according to the customer's requirements.

Series	Temperature stability [°C]	Set temperature range [°C]	Cooling capacity [kW]														Environment	International standards	
			1.2	1.8	2.4	3	4	5	6	9	10	15	20	25	28				
<b>HRSE Basic type</b>	±2.0	10 to 30	●	● 1.6 kW	● 2.2 kW													Indoor use	CE UK CA (Only 230 VAC type)
<b>HRS Standard type</b>	±0.1	5 to 40	●	●	●	●	●	●	●									Indoor use	CE UK CA (Only 60 Hz)
<b>HRS-R Environmentally resistant type</b>	±0.1	5 to 40		●		●		●										Indoor use Electrical box: IP54	CE UK CA
<b>HRS090 Standard type</b>	±0.5	5 to 35								●								Indoor use	CE UK CA (400 V as standard)
<b>HRS100/150 Standard type</b>	±1.0	5 to 35									●	●					Outdoor installation IPX4	CE UK CA (400 V as standard)	
<b>HRSH090 Inverter type</b>	±0.1	5 to 40								●							Indoor use	CE UK CA (400 V as standard, 200 V as an option) (Only 200 V as an option)	
<b>HRSH Inverter type</b>	±0.1	5 to 35									●	●	●	●	●		Outdoor installation IPX4	CE UK CA (400 V as standard, 200 V as an option) (Only 200 V as an option)	
<b>HRLE Basic dual type</b>	CH1	±0.1	15 to 25						● (CH1, 2 total)	● (CH1, 2 total)							Indoor use Electrical box: IPX4	CE UK CA Scheduled to acquire UL Standards (Only 400 V)	
	CH2	±0.5	CH1 +0 to 15																
<b>HRL Inverter dual type</b>	CH1	±0.1	15 to 25							● 9 kW		● 19 kW	● 26 kW				Indoor use	CE UK CA	
	CH2	±0.5	20 to 40							1.0 kW (Max. 1.5 kW)									

## Circulating Fluid Line Equipment

**Flow Switch:** Monitors the flow rate and temperature of the circulating fluid

Refer to the [Web Catalog](#) for details.

**3-Color Display**  
Digital Flow Switch for Water **PF3W(-Z)**  
Integrated with temperature sensor

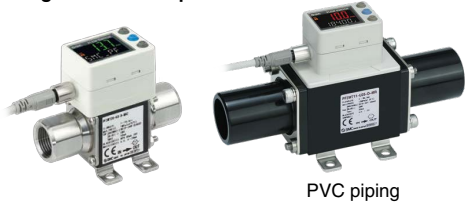

PVC piping

**3-Color Display**  
Electromagnetic Digital Flow Switch **LFE**



**Digital Flow Switch for Deionized Water and Chemical Liquids PF2D**  
**4-Channel Flow Monitor PF2□200**



**Pressure Switch:** Monitors the pressure of the circulating fluid

Refer to the [Web Catalog](#) for details.

**3-Screen Display**  
High-Precision Digital Pressure Switch **Z/ISE20C**



**Pressure Sensor for General Fluids PSE56□**  
**Pressure Sensor Controller PSE200A, 300A**  
**Sensor Monitor PSE300AC**



### Fittings and Tubing

Refer to the [Web Catalog](#) for details.

**S Couplers KK**



**S Couplers/Stainless Steel (Stainless Steel 304) KKA**



**Tubing T□**



Series	Material
T	Nylon
TU	Polyurethane
TH	FEP (Fluoropolymer)
TD	Modified PTFE (Soft fluoropolymer)
TL	Super PFA
TLM	PFA

**Metal One-touch Fittings KQB2**



**Stainless Steel 316 One-touch Fittings KQG2**



**Stainless Steel 316 Insert Fittings KFG2**



**Fluoropolymer Fittings LQ**





# CONTENTS

## **HRLE Series** Compact Dual/Basic Type for Lasers



Air-cooled refrigeration



Water-cooled refrigeration

### Thermo-chiller HRLE Series

How to Order/Specifications

**Air-cooled refrigeration** ..... p. 9

**Water-cooled refrigeration** ..... p. 11

Cooling Capacity ..... p. 13

Pump Capacity ..... p. 13

Dimensions ..... p. 14

Parts Description ..... p. 14

Recommended External Piping Flow ..... p. 16

Cable Specifications ..... p. 16

Operation Display Panel ..... p. 17

Alarm ..... p. 17

Communication Functions ..... p. 18

Options ..... p. 19

Optional Accessories ..... p. 20

### ● Cooling Capacity Calculation

Required Cooling Capacity Calculation ..... p. 24

Precautions on Cooling Capacity Calculation ..... p. 25

Circulating Fluid Typical Physical Property Values ..... p. 25

Specific Product Precautions ..... p. 26

# Thermo-chiller

Compact Dual/Basic Type for Lasers

## HRLE Series



**Power supply** Single-phase 200 to 230 VAC (50/60 Hz)

### How to Order

Air-cooled refrigeration

**HRLE 050 - A - 20 -**

**Cooling capacity**

	CH1, 2 total
050	5 kW

**Cooling method**

A	Air-cooled refrigeration
---	--------------------------

**Power supply**

20	Single-phase 200 to 230 VAC (50/60 Hz)
----	--

**Option**

Nil	None
M	Deionized water (Pure water) piping

• Options "C" and "P" are not available for the HRLE050.



Air-cooled refrigeration

## Specifications

Model		HRLE050-A-20		
<b>Cooling method</b>		Air-cooled refrigeration		
<b>Refrigerant</b>		R410A (HFC)		
<b>Refrigerant charge</b>	kg	1.32		
<b>Control method</b>		PID control		
<b>Ambient temperature</b>		°C 2 to 45		
<b>Circulating fluid system</b>	<b>Circulating fluid</b> *1	Tap water, Deionized (pure) water		
	<b>Set temperature range</b>	°C	CH1: 15 to 25, CH2: CH1 + 0 to 15	
	<b>Cooling capacity (CH1, 2 total) 50/60 Hz</b> *2	kW	4.8/5.8	
	<b>Heating capacity (CH1, 2 total) 50/60 Hz</b> *3	kW	1.3/1.6	
	<b>Temperature stability</b> *4	°C	CH1: ±0.1, CH2: ±0.5	
	<b>Pump capacity</b>	<b>Rated flow 50/60 Hz</b> *5	L/min	CH1: 21/26, CH2: 2/2
		<b>Max. flow rate 50/60 Hz</b>	L/min	29/38
		<b>Max. pump head 50/60 Hz</b>	m	34/50
	<b>Min. operating flow rate 50/60 Hz</b> *6	L/min	CH1: 15/15, CH2: 1/1	
	<b>Tank capacity (CH1, 2 total)</b>	L	Approx. 18	
<b>Circulating fluid outlet, Circulating fluid return port</b>		CH1: Rc1/2, CH2: Rc1/2		
<b>Tank drain port</b>		Rc1/4		
<b>Fluid contact material</b>		Stainless steel, Copper (Heat exchanger brazing), Bronze (Pump), Ceramic, Carbon, FKM, PP, PE, POM, PVC, PA, EPDM		
<b>Fluid contact material (-M)</b>		Stainless steel (Heat exchanger brazing), SiC, Carbon, FKM, PP, PE, POM, PVC, PA, EPDM, PTFE		
<b>Electrical system</b>	<b>Power supply</b>		Single-phase 200 to 230 VAC (50/60 Hz) Allowable voltage range ±10% (No continuous voltage fluctuation)	
	Earth leakage breaker (Standard)	<b>Rated current</b>	A	30
		<b>Sensitivity current</b>	mA	30
	<b>Rated operating current 50/60 Hz</b>		A	12.1/14.4
	<b>Rated power consumption 50/60 Hz</b>		kW(kVA)	2.2/2.8 (2.4/2.9)
<b>Communication function</b>		Contact input/output, Serial communication (RS-485)		
<b>Noise level</b> *7 50/60 Hz		dB(A)	62/64	
<b>Accessories</b> *8		Operation Manual (for installation/operation) 2 copies (English 1 pc./Japanese 1 pc.), Anchor bolt fixing brackets 2 pcs.(including four M8 bolts), Cable accessory 1pc. (For communication cable)		
<b>Weight</b> *9		kg	114	

\*1 Use fluid that fulfills the conditions below as the circulating fluid.  
Tap water: Standard of The Japan Refrigeration And Air Conditioning Industry Association (JRA GL-02-1994)  
Deionized (pure) water: Electric conductivity 0.4 μS/cm or higher (Electric resistivity 2.5 MΩ·cm or lower)

\*2 ① Ambient temperature: 25°C, ② Circulating fluid: Tap water, ③ Circulating fluid temperature: CH1 20°C/CH2 25°C, ④ Circulating fluid flow rate: Rated flow, ⑤ Power supply: 200 VAC

\*3 ① Ambient temperature: 25°C, ② Circulating fluid: Tap water, ③ Circulating fluid flow rate: Rated flow, ④ Power supply: 200 VAC

\*4 ① Ambient temperature: 25°C, ② Circulating fluid: Tap water, ③ Circulating fluid temperature: CH1 20°C/CH2 25°C, ④ Circulating fluid flow rate: Rated flow, ⑤ Power supply: 200 VAC, ⑥ Piping length: Shortest, ⑦ Load: Same as the cooling capacity

\*5 When circulating fluid outlet port pressure = 0.21/0.29 MPa (50/60 Hz)  
\*6 Fluid flow rate to maintain the cooling capacity. If the actual flow rate is lower than this, install a bypass piping.

\*7 Front 1 m/Height 1 m.

\*8 The anchor bolt fixing brackets are used for fixing to wooden skids when packaging the thermo-chiller. No anchor bolt is included.

\*9 Weight when the circulating fluid is not included.

# Thermo-chiller

Compact Dual/Basic Type for Lasers

## HRLE Series



**Power supply** 3-phase 200 VAC (50 Hz)  
3-phase 200 to 230 VAC (60 Hz)

### How to Order

Air-cooled refrigeration

**HRLE 090 - A - 20 -**

**Cooling capacity**

	CH1, 2 total
<b>090</b>	9.5 kW

**Cooling method**

<b>A</b>	Air-cooled refrigeration
----------	--------------------------

**Power supply**

<b>20</b>	3-phase 200 VAC (50 Hz) 3-phase 200 to 230 VAC (60 Hz)
-----------	---

**Option**

<b>Nil</b>	None
<b>C</b>	With inverter for compressor
<b>M</b>	Deionized water (Pure water) piping
<b>P</b>	With inverter for pump

• When multiple options are combined, indicate the symbols in alphabetical order.



Air-cooled refrigeration

## Specifications

Model		HRLE090-A-20		
<b>Cooling method</b>		Air-cooled refrigeration		
<b>Refrigerant</b>		R410A (HFC)		
<b>Refrigerant charge</b>		<b>kg</b>	2	
<b>Control method</b>		PID control		
<b>Ambient temperature</b>		<b>°C</b>	2 to 45	
<b>Circulating fluid system</b>	<b>Circulating fluid</b> <sup>*1</sup>	Tap water, Deionized (pure) water		
	<b>Set temperature range</b>	<b>°C</b>	CH1: 15 to 25, CH2: CH1 + 0 to 15	
	<b>Cooling capacity (CH1, 2 total) 50/60 Hz</b> <sup>*2,*10</sup>	<b>kW</b>	8.0/9.5	
	<b>Heating capacity (CH1, 2 total) 50/60 Hz</b> <sup>*3</sup>	<b>kW</b>	2.0/2.5	
	<b>Temperature stability</b> <sup>*4</sup>	<b>°C</b>	CH1: ±0.1, CH2: ±0.5	
	<b>Pump capacity</b>	<b>Rated flow 50/60 Hz</b> <sup>*5,*11</sup>	<b>L/min</b>	CH1: 25/35 (0.5 MPa), CH2: 2/2 (0.5 MPa)
		<b>Max. flow rate 50/60 Hz</b> <sup>*11</sup>	<b>L/min</b>	55/65
		<b>Max. pump head</b>	<b>m</b>	50
	<b>Settable pressure range (-P)</b>	<b>MPa</b>	0.1 to 0.5	
	<b>Min. operating flow rate 50/60 Hz</b> <sup>*6</sup>	<b>L/min</b>	CH1: 25/35 (-P: 15), CH2: 1/1	
	<b>Tank capacity (CH1, 2 total)</b>	<b>L</b>	Approx. 18	
<b>Circulating fluid outlet, Circulating fluid return port</b>		CH1: Rc1, CH2: Rc1/2		
<b>Tank drain port</b>		Rc1/4		
<b>Fluid contact material</b>		Stainless steel, Copper (Heat exchanger brazing), Bronze (Pump), Ceramic, Carbon, FKM, PP, PE, POM, PVC, PA, EPDM		
<b>Fluid contact material (-M)</b>		Stainless steel (Heat exchanger brazing), SiC, Carbon, FKM, PP, PE, POM, PVC, PA, EPDM, PTFE		
<b>Electrical system</b>	<b>Power supply</b>	3-phase 200 VAC (50 Hz) Allowable voltage range ±10% (No continuous voltage fluctuation) 3-phase 200 to 230 VAC (60 Hz) Allowable voltage range ±10% (No continuous voltage fluctuation)		
	<b>Earth leakage breaker (Standard)</b>	<b>Rated current</b>	<b>A</b>	30
		<b>Sensitivity current</b>	<b>mA</b>	30
	<b>Rated operating current 50/60 Hz</b>	<b>A</b>	14/17	
	<b>Rated power consumption 50/60 Hz</b>	<b>kW(kVA)</b>	4.3/5.3 (4.9/5.8)	
<b>Communication function</b>		Contact input/output, Serial communication (RS-485)		
<b>Noise level</b> <sup>*7</sup>	<b>dB(A)</b>	65		
<b>Accessories</b> <sup>*8</sup>		Operation Manual (for installation/operation) 2 copies (English 1 pc./Japanese 1 pc.), Anchor bolt fixing brackets 2 pcs. (including four M8 bolts), Cable accessory (For communication cable)		
<b>Weight</b> <sup>*9,*12</sup>	<b>kg</b>	140		

- \*1 Use fluid that fulfills the conditions below as the circulating fluid.  
Tap water: Standard of The Japan Refrigeration And Air Conditioning Industry Association (JRA GL-02-1994)  
Deionized (pure) water: Electric conductivity 0.4 μS/cm or higher (Electric resistivity 2.5 MΩ·cm or lower)
- \*2 ① Ambient temperature: 32°C, ② Circulating fluid: Tap water, ③ Circulating fluid temperature: CH1 20°C/CH2 25°C, ④ Circulating fluid flow rate: Rated flow, ⑤ Power supply: 200 VAC
- \*3 ① Ambient temperature: 32°C, ② Circulating fluid: Tap water, ③ Circulating fluid flow rate: Rated flow, ④ Power supply: 200 VAC
- \*4 ① Ambient temperature: 32°C, ② Circulating fluid: Tap water, ③ Circulating fluid temperature: CH1 20°C/CH2 25°C, ④ Circulating fluid flow rate: Rated flow, ⑤ Power

- supply: 200 VAC, ⑥ Piping length: Shortest, ⑦ Load: Same as the cooling capacity
- \*5 Circulating fluid temperature: CH1: 20°C/CH2: 25°C at the device outlet.
- \*6 Fluid flow rate to maintain the cooling capacity. If the actual flow rate is lower than this, install a bypass piping.
- \*7 Front 1 m/Height 1 m.
- \*8 The anchor bolt fixing brackets (including four M8 bolts) are used for fixing to wooden skids when packaging the thermo-chiller. No anchor bolt is included.
- \*9 Weight when the circulating fluid is not included.
- \*10 The capacity is 60 Hz even in the 50 Hz area when option C is selected.
- \*11 The capacity is 60 Hz even in the 50 Hz area when option P is selected.
- \*12 The weight will increase by 4 kg when option C and P is selected.

# Thermo-chiller

Compact Dual/Basic Type for Lasers



## HRLE Series

**Power supply** Single-phase 200 to 230 VAC (50/60 Hz)

### How to Order

Water-cooled refrigeration

**HRLE 050-W-20-**

**Cooling capacity**

	CH1, 2 total
<b>050</b>	5 kW

**Cooling method**

<b>W</b>	Water-cooled refrigeration
----------	----------------------------

**Power supply**

<b>20</b>	Single-phase 200 to 230 VAC (50/60 Hz)
-----------	--

**Option**

<b>Nil</b>	None
<b>M</b>	Deionized water (Pure water) piping

• Options "C" and "P" are not available for the HRLE050.



### Specifications

Model		HRLE050-W-20		
<b>Cooling method</b>		Water-cooled refrigeration		
<b>Refrigerant</b>		R410A (HFC)		
<b>Refrigerant charge</b> kg		1.2		
<b>Control method</b>		PID control		
<b>Ambient temperature</b> °C		2 to 45		
<b>Circulating fluid system</b>	<b>Circulating fluid</b> *1	Tap water, Deionized (pure) water		
	<b>Set temperature range</b> °C	CH1: 15 to 25, CH2: CH1 + 0 to 15		
	<b>Cooling capacity (CH1, 2 total) 50/60 Hz</b> *2 kW	4.8/5.8		
	<b>Heating capacity (CH1, 2 total) 50/60 Hz</b> *3 kW	1.2/1.5		
	<b>Temperature stability</b> *4 °C	CH1: ±0.1, CH2: ±0.5		
	<b>Pump capacity</b>	<b>Rated flow 50/60 Hz</b> *5 L/min	CH1: 21/26, CH2: 2/2	
		<b>Max. flow rate 50/60 Hz</b> L/min	29/38	
		<b>Max. pump head 50/60 Hz</b> m	34/50	
	<b>Min. operating flow rate 50/60 Hz</b> *6 L/min	CH1: 15/15, CH2: 1/1		
	<b>Tank capacity (CH1, 2 total)</b> L	Approx. 18		
<b>Circulating fluid outlet, Circulating fluid return port</b>		CH1: Rc1/2, CH2: Rc1/2		
<b>Tank drain port</b>		Rc1/4		
<b>Fluid contact material</b>		Stainless steel, Copper (Heat exchanger brazing), Bronze (Pump), Ceramic, Carbon, FKM, PP, PE, POM, PVC, PA, EPDM		
<b>Fluid contact material (-M)</b>		Stainless steel (Heat exchanger brazing), SiC, Carbon, FKM, PP, PE, POM, PVC, PA, EPDM, PTFE		
<b>Facility water system</b>	<b>Temperature range</b> °C	5 to 40		
	<b>Pressure range</b> MPa	0.3 to 0.5		
	<b>Required flow 50/60 Hz</b> *7 L/min	16		
	<b>Facility water pressure differential</b> MPa	0.3 or more		
	<b>Facility water inlet/outlet</b>	Rc1/2		
<b>Fluid contact material</b>		Stainless steel, Copper (Heat exchanger brazing), Brass, PTFE, NBR, EPDM		
<b>Electrical system</b>	<b>Power supply</b>			
	Single-phase 200 to 230 VAC (50/60 Hz)			
	Allowable voltage range ±10% (No continuous voltage fluctuation)			
	<b>Earth leakage breaker (Standard)</b>	<b>Rated current</b> A	30	
		<b>Sensitivity current</b> mA	30	
	<b>Rated operating current 50/60 Hz</b> A	10.9/12.7		
	<b>Rated power consumption 50/60 Hz</b> kW(kVA)	2.0/2.4 (2.1/2.5)		
<b>Communication function</b>		Contact input/output, Serial communication (RS-485)		
<b>Noise level</b> *8 50/60 Hz dB(A)		62/64		
<b>Accessories</b> *9		Operation Manual (for installation/operation) 2 copies (English 1 pc./Japanese 1 pc.), Anchor bolt fixing brackets 2 pcs.(including four M8 bolts), Cable accessory 1 pc. (For communication cable)		
<b>Weight</b> *10 kg		134		

\*1 Use fluid that fulfills the conditions below as the circulating fluid.  
Tap water: Standard of The Japan Refrigeration And Air Conditioning Industry Association (JRA GL-02-1994)  
Deionized (pure) water: Electric conductivity 0.4 μS/cm or higher (Electric resistivity 2.5 MΩ·cm or lower)

\*2 ① Facility water temperature: 25°C, ② Circulating fluid: Tap water, ③ Circulating fluid temperature: CH1 20°C/CH2 25°C, ④ Circulating fluid flow rate: Rated flow, ⑤ Power supply: 200 VAC

\*3 ① Facility water temperature: 25°C, ② Circulating fluid: Tap water, ③ Circulating fluid flow rate: Rated flow, ④ Power supply: 200 VAC

\*4 ① Facility water temperature: 25°C, ② Circulating fluid: Tap water, ③ Circulating fluid temperature: CH1 20°C/CH2 25°C, ④ Circulating

fluid flow rate: Rated flow, ⑤ Power supply: 200 VAC, ⑥ Piping length: Shortest, ⑦ Load: Same as the cooling capacity

\*5 When circulating fluid outlet port pressure = 0.21/0.29 MPa (50/60 Hz)  
\*6 Fluid flow rate to maintain the cooling capacity. If the actual flow rate is lower than this, install a bypass piping.

\*7 The required flow rate when the cooling capacity load is applied at a circulating fluid temperature of 20°C, and circulating fluid rated flow and facility water temperature of 25°C

\*8 Front 1 m/Height 1 m.

\*9 The anchor bolt fixing brackets are used for fixing to wooden skids when packaging the thermo-chiller. No anchor bolt is included.

\*10 Weight when the circulating fluid is not included.

# Thermo-chiller

Compact Dual/Basic Type for Lasers



## HRLE Series

**Power supply** 3-phase 200 VAC (50 Hz)  
3-phase 200 to 230 VAC (60 Hz)

### How to Order

Water-cooled refrigeration

**HRLE 090-W-20-**

**Cooling capacity**

	CH1, 2 total
<b>090</b>	9.5 kW

**Cooling method**

<b>W</b>	Water-cooled refrigeration
----------	----------------------------

**Power supply**

<b>20</b>	3-phase 200 VAC (50 Hz)
	3-phase 200 to 230 VAC (60 Hz)

**Option**

<b>Nil</b>	None
<b>C</b>	With inverter for compressor
<b>M</b>	Deionized water (Pure water) piping
<b>P</b>	With inverter for pump

• When multiple options are combined, indicate the symbols in alphabetical order.



## Specifications

Model		HRLE090-W-20		
<b>Cooling method</b>		Water-cooled refrigeration		
<b>Refrigerant</b>		R410A (HFC)		
<b>Refrigerant charge</b> kg		1.9		
<b>Control method</b>		PID control		
<b>Ambient temperature</b> °C		2 to 45		
<b>Circulating fluid system</b>	<b>Circulating fluid</b> *1	Tap water, Deionized (pure) water		
	<b>Set temperature range</b> °C	CH1: 15 to 25, CH2: CH1 + 0 to 15		
	<b>Cooling capacity (CH1, 2 total) 50/60 Hz</b> *2,*10 kW	9.5/11.0		
	<b>Heating capacity (CH1, 2 total) 50/60 Hz</b> *3 kW	2.0/2.5		
	<b>Temperature stability</b> *4 °C	CH1: ±0.1, CH2: ±0.5		
	<b>Pump capacity</b>	<b>Rated flow 50/60 Hz</b> *5,*11 L/min	CH1: 25/35 (0.5 MPa), CH2: 2/2 (0.5 MPa)	
		<b>Max. flow rate 50/60 Hz</b> *11 L/min	55/65	
		<b>Max. pump head</b> m	50	
	<b>Settable pressure range (-P) MPa</b>		0.1 to 0.5	
	<b>Min. operating flow rate 50/60 Hz</b> *6 L/min		CH1: 25/35 (-P: 15), CH2: 1/1	
	<b>Tank capacity (CH1, 2 total) L</b>		Approx. 18	
<b>Circulating fluid outlet, Circulating fluid return port</b>		CH1: Rc1, CH2: Rc1/2		
<b>Tank drain port</b>		Rc1/4		
<b>Fluid contact material</b>		Stainless steel, Copper (Heat exchanger brazing), Bronze (Pump), Ceramic, Carbon, FKM, PP, PE, POM, PVC, PA, EPDM		
<b>Fluid contact material (-M)</b>		Stainless steel (Heat exchanger brazing), SiC, Carbon, FKM, PP, PE, POM, PVC, PA, EPDM, PTFE		
<b>Facility water system</b>	<b>Temperature range</b> °C	5 to 40		
	<b>Pressure range</b> MPa	0.3 to 0.5		
	<b>Required flow 50/60 Hz</b> L/min	25/25		
	<b>Facility water pressure differential</b> MPa	0.3 or more		
	<b>Facility water inlet/outlet</b>		Rc1/2	
<b>Fluid contact material</b>		Stainless steel, Copper (Heat exchanger brazing), Brass, PTFE, NBR, EPDM		
<b>Electrical system</b>	<b>Power supply</b>		3-phase 200 VAC (50 Hz) Allowable voltage range ±10% (No continuous voltage fluctuation) 3-phase 200 to 230 VAC (60 Hz) Allowable voltage range ±10% (No continuous voltage fluctuation)	
	<b>Earth leakage breaker (Standard)</b>	<b>Rated current</b> A	30	
		<b>Sensitivity current</b> mA	30	
	<b>Rated operating current 50/60 Hz</b> A		13.5/14.4	
	<b>Rated power consumption 50/60 Hz</b> kW(kVA)		3.5/4.4 (4.7/5.0)	
<b>Communication function</b>		Contact input/output, Serial communication (RS-485)		
<b>Noise level</b> *7 dB(A)		65		
<b>Accessories</b> *8		Operation Manual (for installation/operation) 2 copies (English 1 pc./Japanese 1 pc.), Anchor bolt fixing brackets 2 pcs.(including four M8 bolts), Cable accessory 1 pc. (For communication cable)		
<b>Weight</b> *9,*12 kg		134		

\*1 Use fluid that fulfills the conditions below as the circulating fluid.  
Tap water: Standard of The Japan Refrigeration And Air Conditioning Industry Association (JRA GL-02-1994)  
Deionized (pure) water: Electric conductivity 0.4 μS/cm or higher (Electric resistivity 2.5 MΩ·cm or lower)

\*2 ① Ambient temperature: 32°C, ② Circulating fluid: Tap water, ③ Circulating fluid temperature: CH1 20°C/CH2 25°C, ④ Circulating fluid flow rate: Rated flow, ⑤ Power supply: 200 VAC

\*3 ① Ambient temperature: 32°C, ② Circulating fluid: Tap water, ③ Circulating fluid flow rate: Rated flow, ④ Power supply: 200 VAC

\*4 ① Ambient temperature: 32°C, ② Circulating fluid: Tap water, ③ Circulating fluid temperature: CH1 20°C/CH2 25°C, ④ Circulating fluid flow rate: Rated

flow, ⑤ Power supply: 200 VAC, ⑥ Piping length: Shortest, ⑦ Load: Same as the cooling capacity

\*5 Circulating fluid temperature: CH1 : 20°C/CH2 : 25°C at the device outlet.

\*6 Fluid flow rate to maintain the cooling capacity. If the actual flow rate is lower than this, install a bypass piping.

\*7 Front 1 m/Height 1 m.

\*8 The anchor bolt fixing brackets (including four M8 bolts) are used for fixing to wooden skids when packaging the thermo-chiller. No anchor bolt is included.

\*9 Weight when the circulating fluid is not included.

\*10 The capacity is 60 Hz even in the 50 Hz area when option C is selected.

\*11 The capacity is 60 Hz even in the 50 Hz area when option P is selected.

\*12 The weight will increase by 4 kg when option C and P is selected.



Scheduled to acquire UL Standards



Power supply	3-phase 380 to 415 VAC (50/60 Hz)
	3-phase 460 to 480 VAC (60 Hz)

## How to Order

Air-cooled refrigeration

# HRLE 090 - A - 40 - □

Cooling capacity

	CH1, 2 total
090	9.5 kW

Cooling method

A	Air-cooled refrigeration
---	--------------------------

Power supply

40	3-phase 380 to 415 VAC (50/60 Hz)
	3-phase 460 to 480 VAC (60 Hz)

Option

Nil	None
C	With inverter for compressor
M	Deionized water (Pure water) piping
P	With inverter for pump

• When multiple options are combined, indicate the symbols in alphabetical order.



Air-cooled refrigeration

## Specifications

Model		HRLE090-A-40		
Cooling method		Air-cooled refrigeration		
Refrigerant		R410A (HFC)		
Refrigerant charge		kg	2	
Control method		PID control		
Ambient temperature		°C	2 to 45	
Circulating fluid system	Circulating fluid*1		Tap water, Deionized (pure) water	
	Set temperature range		°C	CH1: 15 to 25, CH2: CH1 + 0 to 15
	Cooling capacity (CH1, 2 total) 50/60 Hz*2,*11		kW	8.0/9.5
	Heating capacity (CH1, 2 total) 50/60 Hz*3		kW	2.0/2.5
	Temperature stability*4		°C	CH1: ±0.1, CH2: ±0.5
	Pump capacity	Rated flow 50/60 Hz*5,*12	L/min	CH1: 25/35 (0.5 MPa), CH2: 2/2 (0.5 MPa)
		Max. flow rate 50/60 Hz*12	L/min	55/65
		Max. pump head	m	50
	Settable pressure range (-P)		MPa	0.1 to 0.5
	Min. operating flow rate 50/60 Hz*6		L/min	CH1: 25/35 (-P: 15), CH2: 1/1
	Tank capacity (CH1, 2 total)		L	Approx. 18
Circulating fluid outlet, Circulating fluid return port		CH1: Rc1, CH2: Rc1/2		
Tank drain port		Rc1/4		
Fluid contact material		Stainless steel, Copper (Heat exchanger brazing), Bronze (Pump), Ceramic, Carbon, FKM, PP, PE, POM, PVC, PA, EPDM		
Fluid contact material (-M)		Stainless steel (Heat exchanger brazing), SiC, Carbon, FKM, PP, PE, POM, PVC, PA, EPDM, PTFE		
Electrical system	Power supply		3-phase 380 to 415 VAC (50/60 Hz) Allowable voltage range ±10% (No continuous voltage fluctuation) 3-phase 460 to 480 VAC (60 Hz) Allowable voltage range +4%, -10% (Max. voltage less than 500 V and no continuous voltage fluctuation)	
	Applicable earth leakage breaker*7	Rated current	A	20
		Sensitivity current	mA	30
	Rated operating current 50/60 Hz		A	6.8/8.2
	Rated power consumption 50/60 Hz		kW(kVA)	4.3/5.3 (4.9/5.8)
Communication function		Contact input/output, Serial communication (RS-485)		
Noise level*8		dB(A)	67	
Accessories*9		Operation Manual (for installation/operation) 2 copies (English 1 pc./Japanese 1 pc.), Anchor bolt fixing brackets 2 pcs.(including four M8 bolts), Cable accessory (For communication cable)		
Weight*10,*13		kg	140	

\*1 Use fluid that fulfills the conditions below as the circulating fluid.  
Tap water: Standard of The Japan Refrigeration And Air Conditioning Industry Association (JRA GL-02-1994)  
Deionized (pure) water: Electric conductivity 0.4 μS/cm or higher (Electric resistivity 2.5 MΩ·cm or lower)  
\*2 ① Ambient temperature: 32°C, ② Circulating fluid: Tap water, ③ Circulating fluid temperature: CH1 20°C/CH2 25°C, ④ Circulating fluid flow rate: Rated flow, ⑤ Power supply: 400 VAC  
\*3 ① Ambient temperature: 32°C, ② Circulating fluid: Tap water, ③ Circulating fluid flow rate: Rated flow, ④ Power supply: 400 VAC  
\*4 ① Ambient temperature: 32°C, ② Circulating fluid: Tap water, ③ Circulating fluid temperature: CH1 20°C/CH2 25°C, ④ Circulating fluid flow rate: Rated flow, ⑤ Power

supply: 400 VAC, ⑥ Piping length: Shortest, ⑦ Load: Same as the cooling capacity  
\*5 Circulating fluid temperature: CH1 : 20°C/CH2 : 25°C at the device outlet.  
\*6 Fluid flow rate to maintain the cooling capacity. If the actual flow rate is lower than this, install a bypass piping.  
\*7 To be prepared by the user.  
\*8 Front 1 m/Height 1 m.  
\*9 The anchor bolt fixing brackets (including four M8 bolts) are used for fixing to wooden skids when packaging the thermo-chiller. No anchor bolt is included.  
\*10 Weight when the circulating fluid is not included.  
\*11 The capacity is 60 Hz even in the 50 Hz area when option C is selected.  
\*12 The capacity is 60 Hz even in the 50 Hz area when option P is selected.  
\*13 The weight will increase by 4 kg when option C and P is selected.



Scheduled to acquire UL Standards



Power supply	3-phase 380 to 415 VAC (50/60 Hz)
	3-phase 460 to 480 VAC (60 Hz)

**How to Order**

Water-cooled refrigeration **HRLE 090-W-40-**

**Cooling capacity**

	CH1, 2 total
<b>090</b>	9.5 kW

**Cooling method**

<b>W</b>	Water-cooled refrigeration
----------	----------------------------

**Power supply**

<b>40</b>	3-phase 380 to 415 VAC (50/60 Hz)
	3-phase 460 to 480 VAC (60 Hz)

**Option**

<b>Nil</b>	None
<b>C</b>	With inverter for compressor
<b>M</b>	Deionized water (Pure water) piping
<b>P</b>	With inverter for pump

• When multiple options are combined, indicate the symbols in alphabetical order.



**Specifications**

Model		HRLE090-W-40		
<b>Cooling method</b>		Water-cooled refrigeration		
<b>Refrigerant</b>		R410A (HFC)		
<b>Refrigerant charge</b>		kg 1.9		
<b>Control method</b>		PID control		
<b>Ambient temperature</b>		°C 2 to 45		
<b>Circulating fluid system</b>	<b>Circulating fluid</b> <sup>*1</sup>		Tap water, Deionized (pure) water	
	<b>Set temperature range</b>		°C CH1: 15 to 25, CH2: CH1 + 0 to 15	
	<b>Cooling capacity (CH1, 2 total) 50/60 Hz</b> <sup>*2,*11</sup>		kW 9.5/11.0	
	<b>Heating capacity (CH1, 2 total) 50/60 Hz</b> <sup>*3</sup>		kW 2.0/2.5	
	<b>Temperature stability</b> <sup>*4</sup>		°C CH1: ±0.1, CH2: ±0.5	
	<b>Pump capacity</b>	<b>Rated flow 50/60 Hz</b> <sup>*5,*12</sup>	L/min	CH1: 25/35 (0.5 MPa), CH2: 2/2 (0.5 MPa)
		<b>Max. flow rate 50/60 Hz</b> <sup>*12</sup>	L/min	55/65
		<b>Max. pump head</b>	m	50
	<b>Settable pressure range (-P)</b>		MPa	0.1 to 0.5
	<b>Min. operating flow rate 50/60 Hz</b> <sup>*6</sup>		L/min	CH1: 25/35 (-P: 15), CH2: 1/1
<b>Tank capacity (CH1, 2 total)</b>		L	Approx. 18	
<b>Circulating fluid outlet, Circulating fluid return port</b>		CH1: Rc1, CH2: Rc1/2		
<b>Tank drain port</b>		Rc1/4		
<b>Fluid contact material</b>		Stainless steel, Copper (Heat exchanger brazing), Bronze (Pump), Ceramic, Carbon, FKM, PP, PE, POM, PVC, PA, EPDM		
<b>Fluid contact material (-M)</b>		Stainless steel (Heat exchanger brazing), SiC, Carbon, FKM, PP, PE, POM, PVC, PA, EPDM, PTFE		
<b>Facility water system</b>	<b>Temperature range</b>		°C 5 to 40	
	<b>Pressure range</b>		MPa 0.3 to 0.5	
	<b>Required flow 50/60 Hz</b>		L/min 25/25	
	<b>Facility water pressure differential</b>		MPa 0.3 or more	
	<b>Facility water inlet/outlet</b>		Rc1/2	
<b>Fluid contact material</b>		Stainless steel, Copper (Heat exchanger brazing), Brass, PTFE, NBR, EPDM		
<b>Electrical system</b>	<b>Power supply</b>		3-phase 380 to 415 VAC (50/60 Hz) Allowable voltage range ±10% (No continuous voltage fluctuation) 3-phase 460 to 480 VAC (60 Hz) Allowable voltage range +4%, -10% (Max. voltage less than 500 V and no continuous voltage fluctuation)	
	<b>Applicable earth leakage breaker</b> <sup>*7</sup>	<b>Rated current</b>	A 20	
		<b>Sensitivity current</b>	mA 30	
	<b>Rated operating current 50/60 Hz</b>		A 6.7/7.1	
	<b>Rated power consumption 50/60 Hz</b>		kW(kVA) 3.5/4.4 (4.7/5.0)	
<b>Communication function</b>		Contact input/output, Serial communication (RS-485)		
<b>Noise level</b> <sup>*8</sup>		dB(A) 65		
<b>Accessories</b> <sup>*9</sup>		Operation Manual (for installation/operation) 2 copies (English 1 pc./Japanese 1 pc.), Anchor bolt fixing brackets 2 pcs.(including four M8 bolts), Cable accessory 1 pc. (For communication cable)		
<b>Weight</b> <sup>*10,*13</sup>		kg 134		

\*1 Use fluid that fulfills the conditions below as the circulating fluid.  
Tap water: Standard of The Japan Refrigeration And Air Conditioning Industry Association (JRA GL-02-1994)  
Deionized (pure) water: Electric conductivity 0.4 μS/cm or higher (Electric resistivity 2.5 MΩ·cm or lower)

\*2 ① Ambient temperature: 32°C, ② Circulating fluid: Tap water, ③ Circulating fluid temperature: CH1 20°C/CH2 25°C, ④ Circulating fluid flow rate: Rated flow, ⑤ Power supply: 400 VAC

\*3 ① Ambient temperature: 32°C, ② Circulating fluid: Tap water, ③ Circulating fluid flow rate: Rated flow, ④ Power supply: 400 VAC

\*4 ① Ambient temperature: 32°C, ② Circulating fluid: Tap water, ③ Circulating fluid temperature: CH1 20°C/CH2 25°C, ④ Circulating fluid flow rate: Rated flow, ⑤ Power supply: 400 VAC, ⑥ Piping length: Shortest, ⑦ Load: Same as the cooling capacity

\*5 Circulating fluid temperature: CH1 : 20°C/CH2 : 25°C at the device outlet.

\*6 Fluid flow rate to maintain the cooling capacity. If the actual flow rate is lower than this, install a bypass piping.

\*7 To be prepared by the user.

\*8 Front 1 m/Height 1 m.

\*9 The anchor bolt fixing brackets (including four M8 bolts) are used for fixing to wooden skids when packaging the thermo-chiller. No anchor bolt is included.

\*10 Weight when the circulating fluid is not included.

\*11 The capacity is 60 Hz even in the 50 Hz area when option C is selected.

\*12 The capacity is 60 Hz even in the 50 Hz area when option P is selected.

\*13 The weight will increase by 4 kg when option C and P is selected.

## Cooling Capacity

**HRLE050-A-20** [50 Hz]

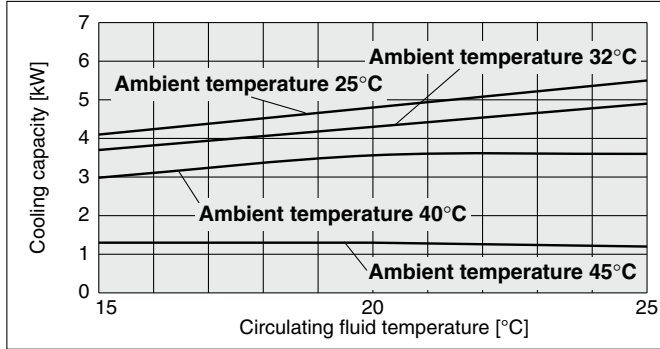

\* The cooling capacity is the sum of the capacities of CH1 and CH2.

**HRLE050-A-20** [60 Hz]

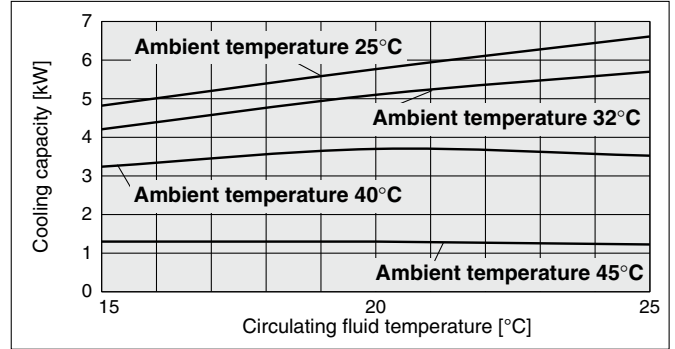

**HRLE050-W-20** [50 Hz]

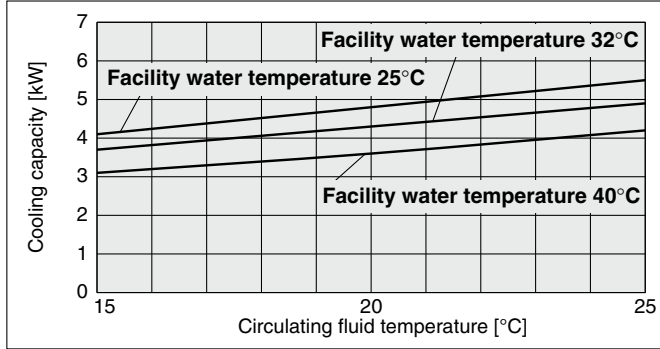

\* The cooling capacity is the sum of the capacities of CH1 and CH2.

**HRLE050-W-20** [60 Hz]

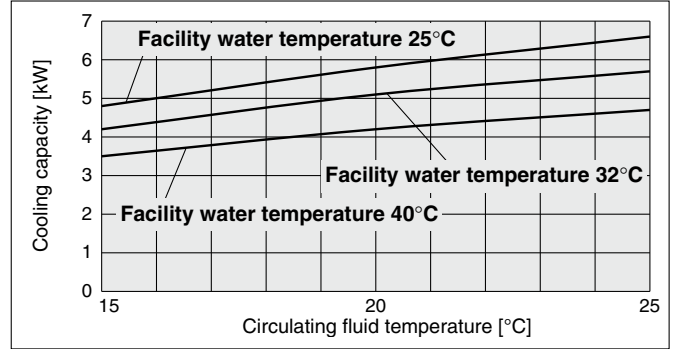

**HRLE090-A-20/40** [50 Hz]

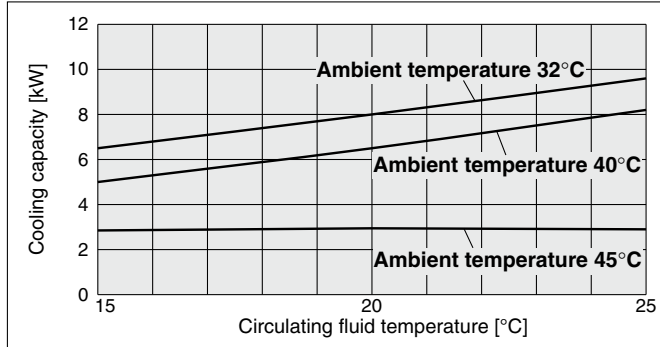

\* The cooling capacity is the sum of the capacities of CH1 and CH2.  
 \* The ambient temperature of 32°C is at 60% fan output (default setting).  
 \* The ambient temperatures of 40°C and 45°C are at 100% fan output. (The noise level rises by approx. 3 dB(A) from the rated condition.)

**HRLE090-A-20/40** [60 Hz]

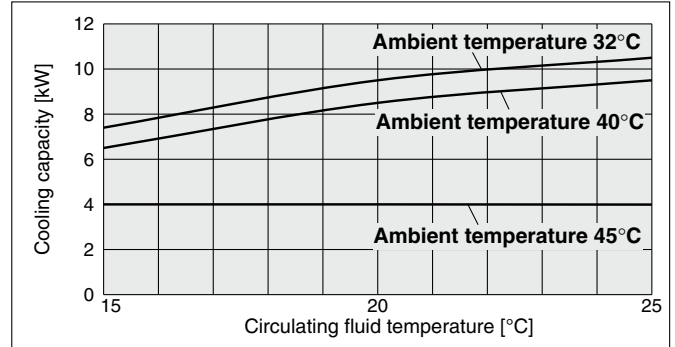

**HRLE090-W-20/40** [50 Hz]

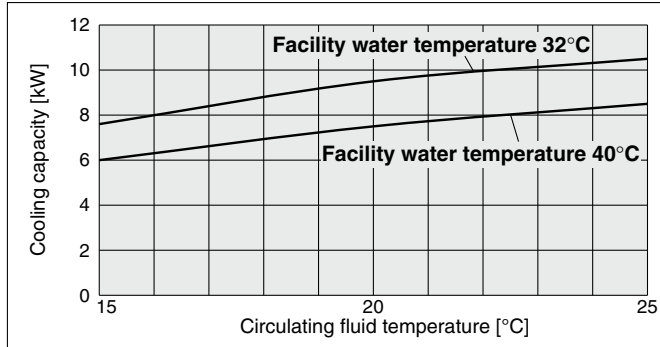

\* The cooling capacity is the sum of the capacities of CH1 and CH2.

**HRLE090-W-20/40** [60 Hz]

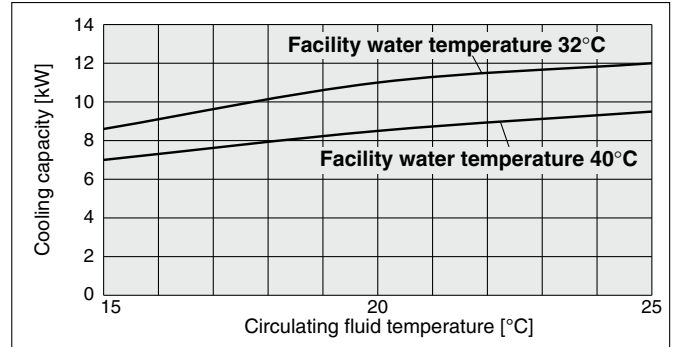



## Heating Capacity

**HRLE050-A-20** [50 Hz]

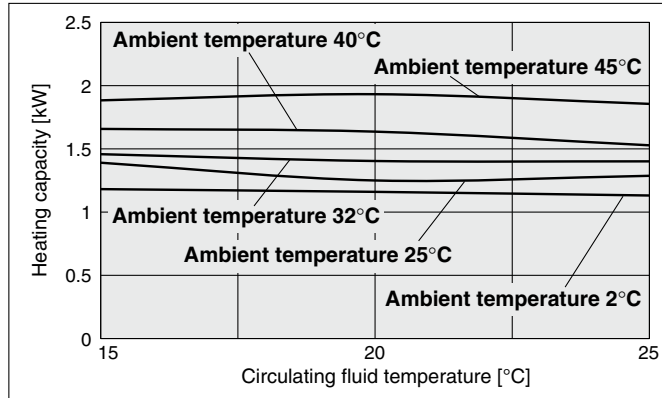

**HRLE050-A-20** [60 Hz]

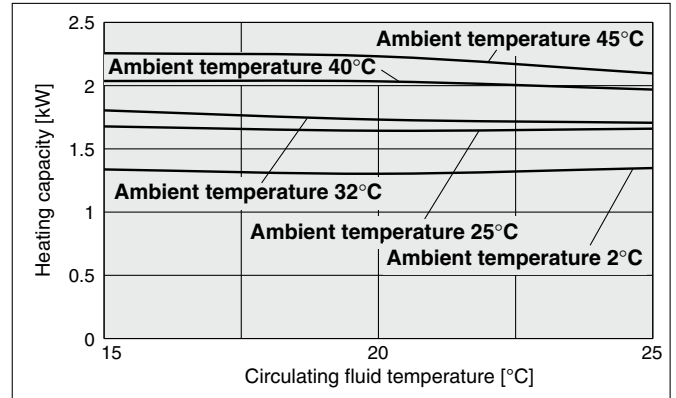

**HRLE050-W-20** [50 Hz]

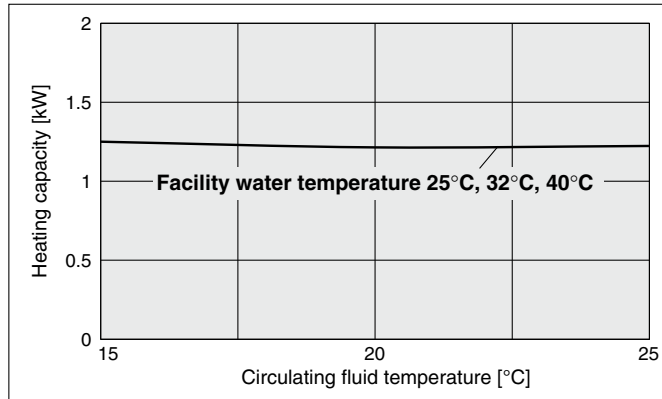

**HRLE050-W-20** [60 Hz]

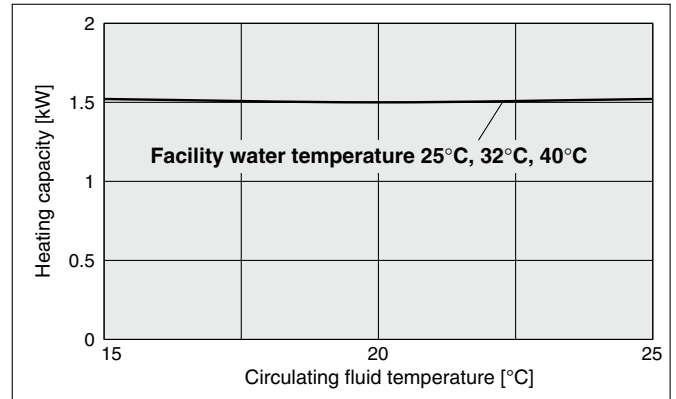

## Pump Capacity

### HRLE050-□-20

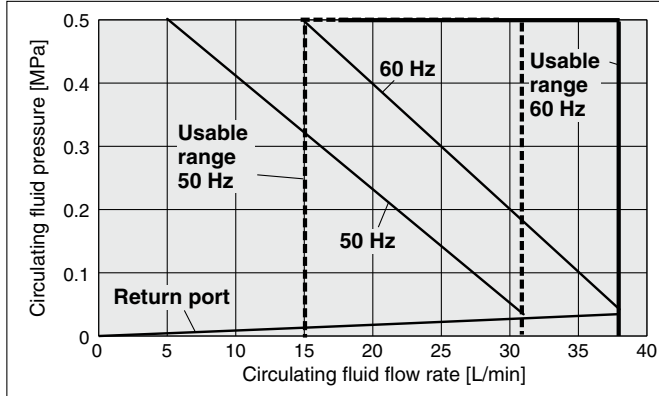

\* The pump capacity is the capacity of CH1 when 2 L/min are applied to CH2.

### HRLE090-□-20/40

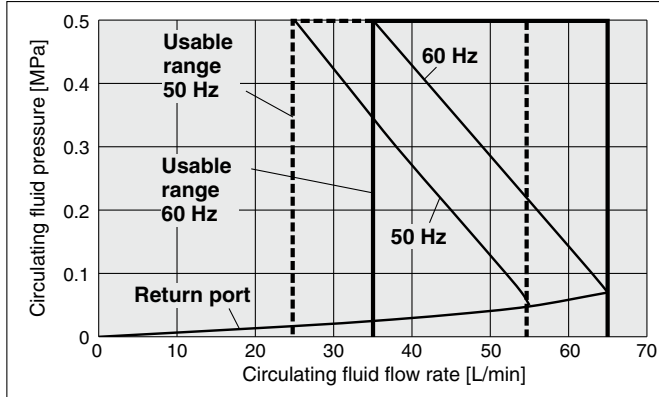

\* The pump capacity is the capacity of CH1 when 2 L/min are applied to CH2.

## Required Facility Water Flow Rate

### HRLE050-W-20

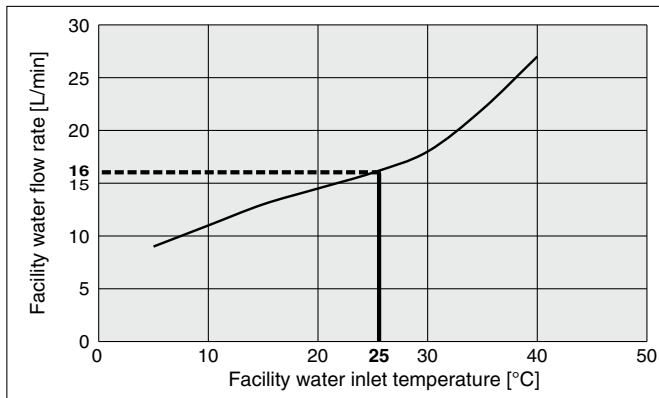

\* This is the facility water flow rate at the circulating fluid rated flow and the cooling capacity listed in the "Cooling Capacity" specifications.

## ⚠ Caution

### Mechanical Seal Pump

The pump used for the thermo-chiller HRLE series uses a mechanical seal with the fixed ring and rotary ring used for the shaft seal part. If foreign matter enter the gap between the seals, this may cause a trouble such as leakage from the seal part or pump lock. Therefore, it is strongly recommended to install the particle filter in the return piping of the chiller.

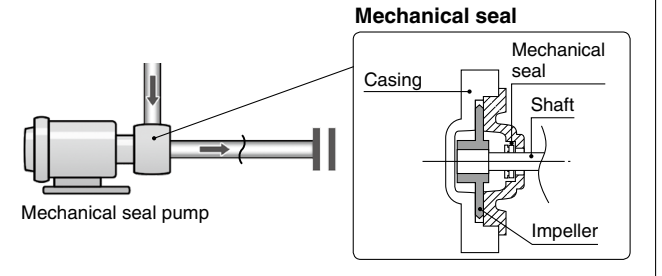

## Dimensions

### HRLE050-A-20

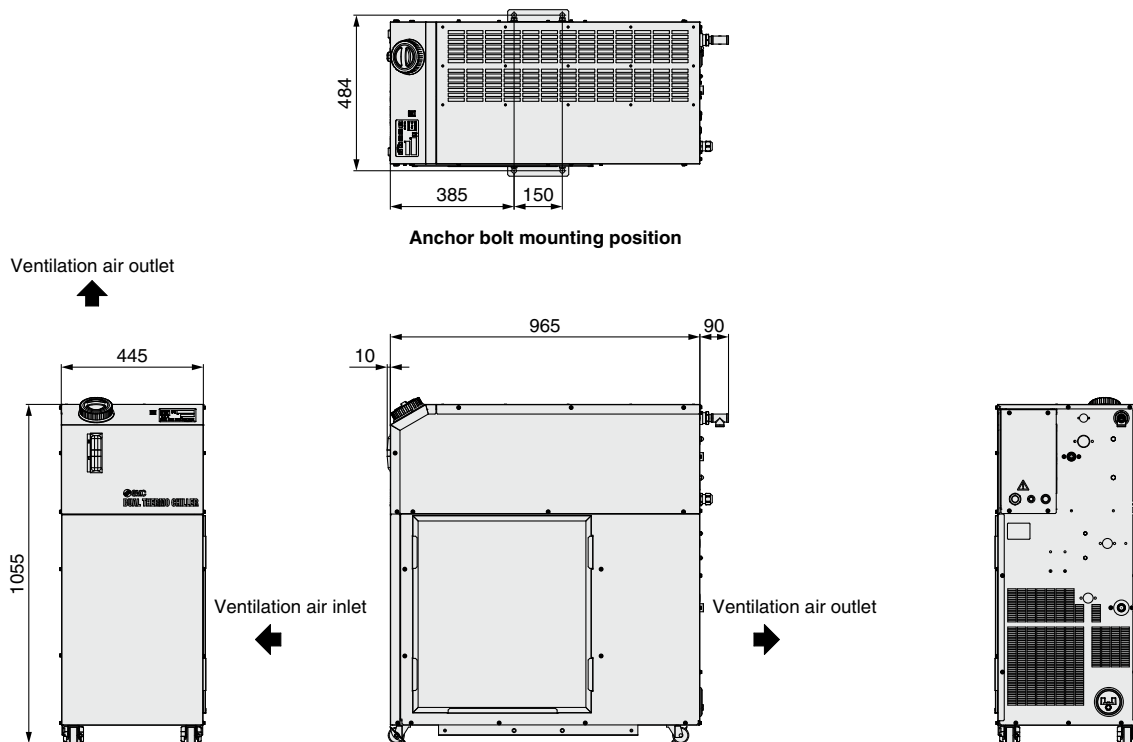

## Parts Description

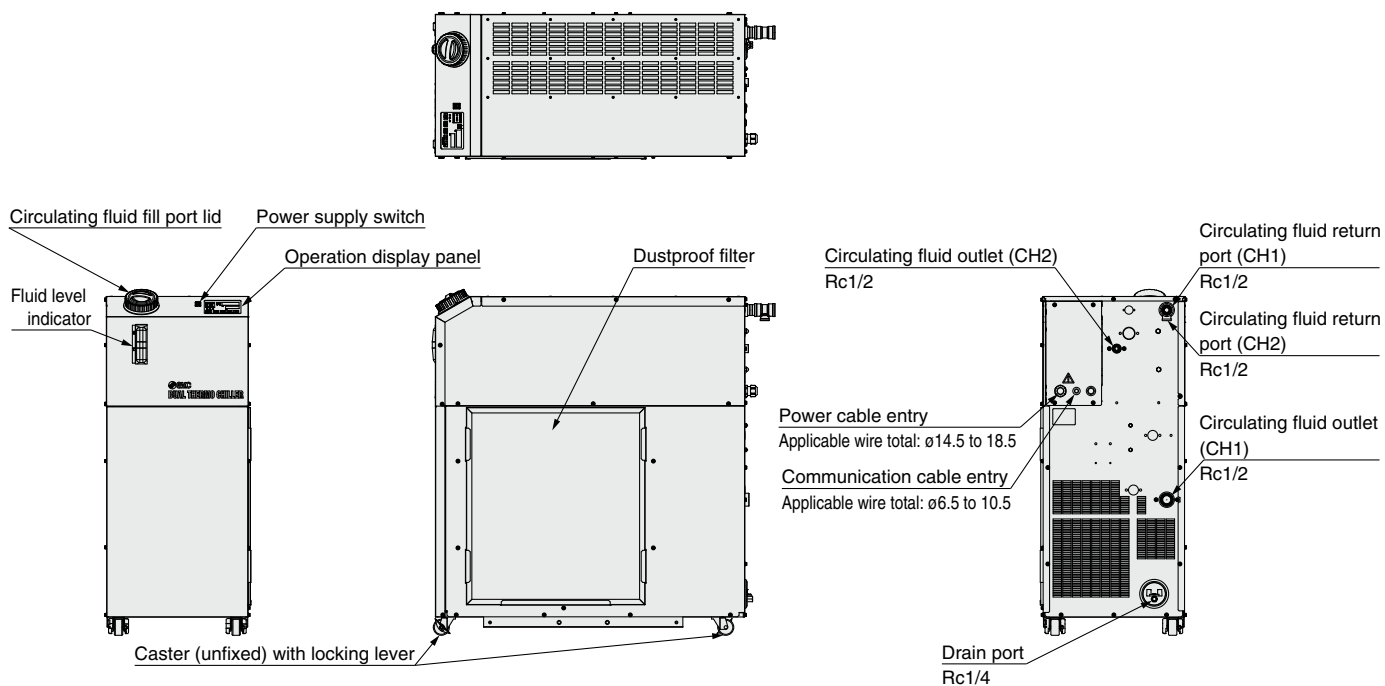

## Dimensions

### HRLE050-W-20

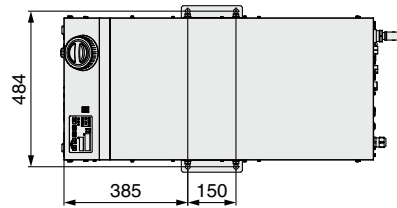

Anchor bolt mounting position

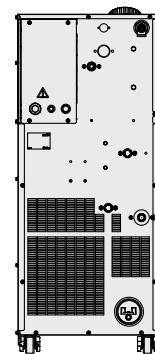
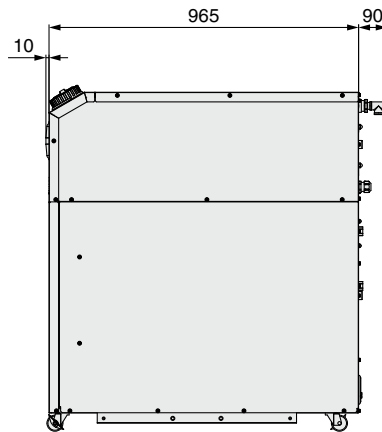
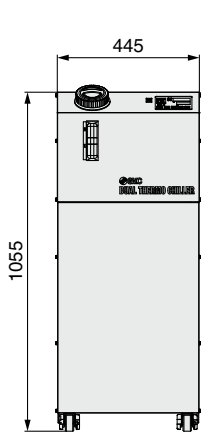

## Parts Description

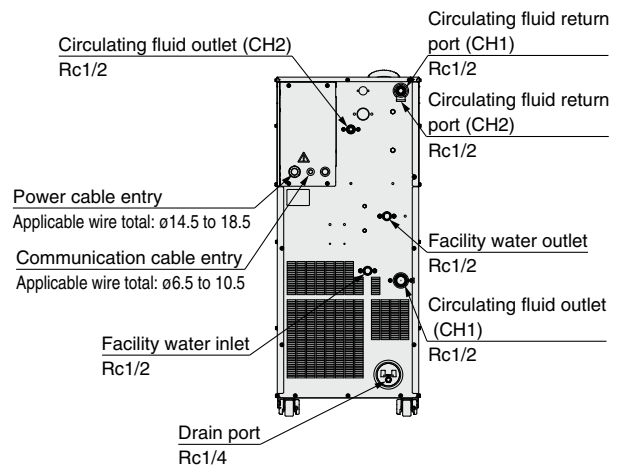
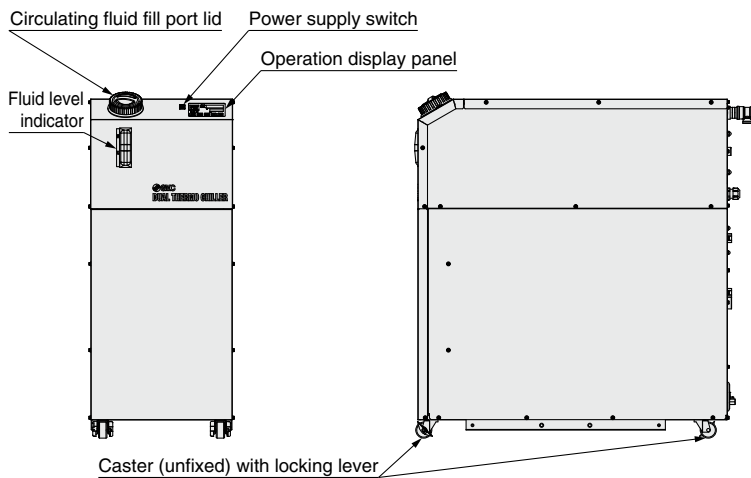
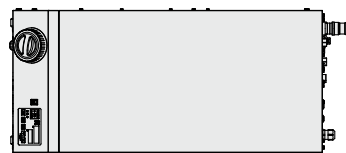

## Dimensions

### HRLE090-A-20/40

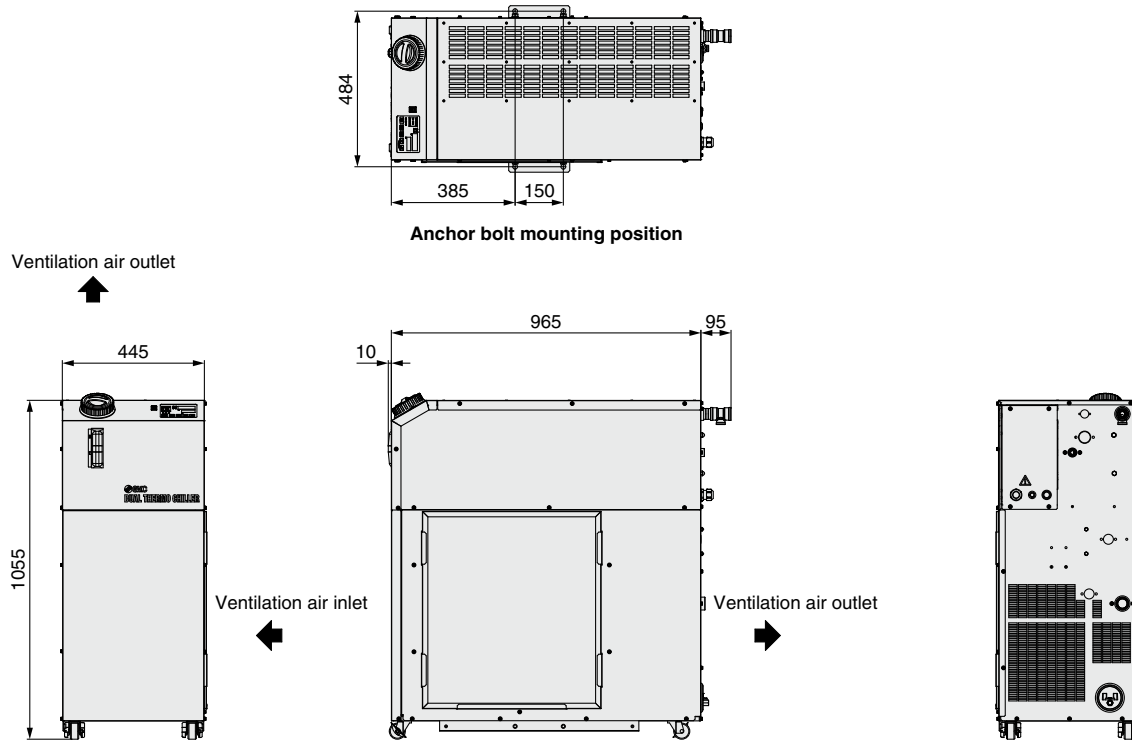

## Parts Description

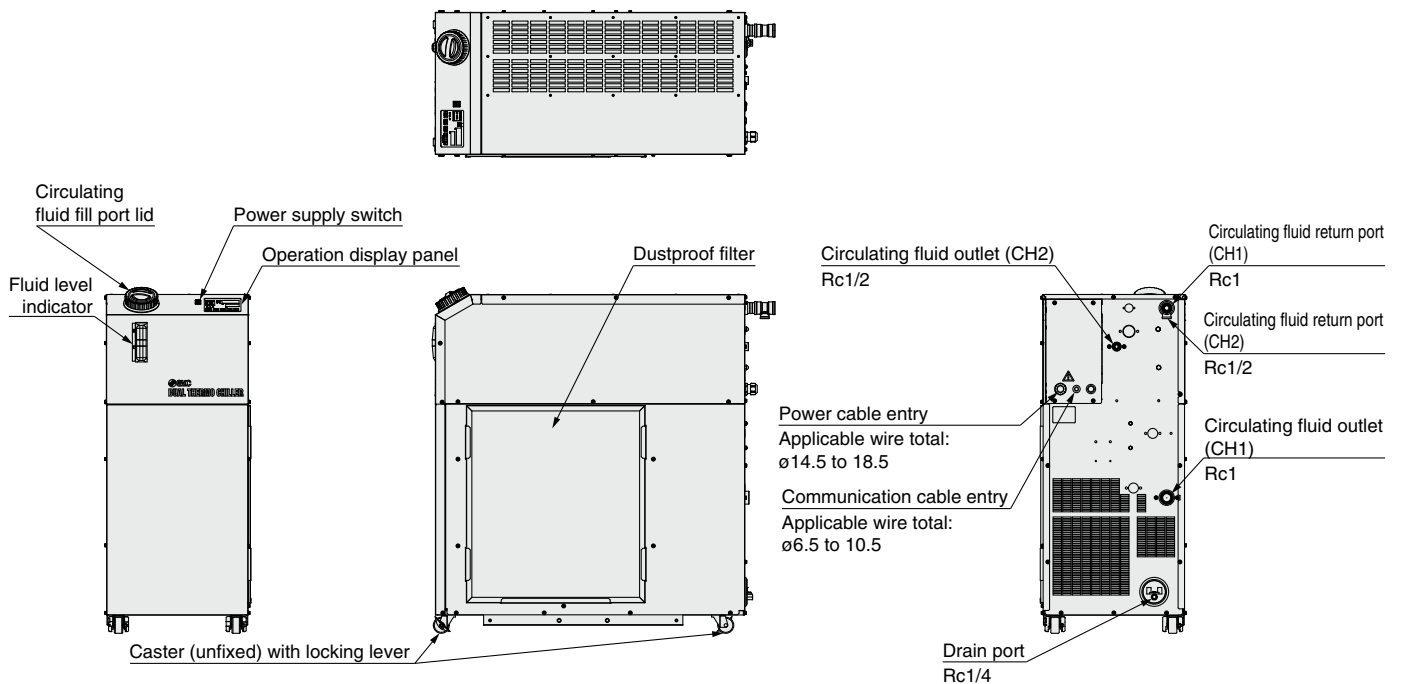

## Dimensions

### HRLE090-W-20/40

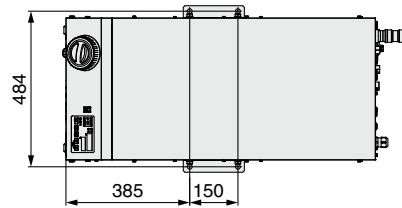

Anchor bolt mounting position

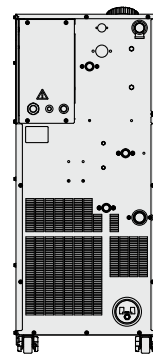
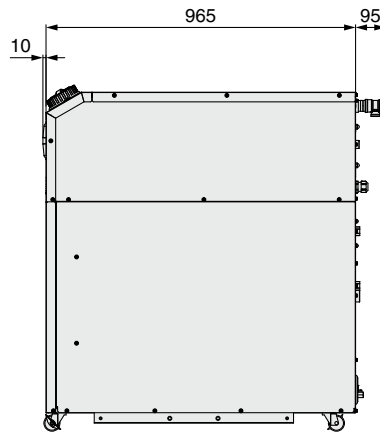
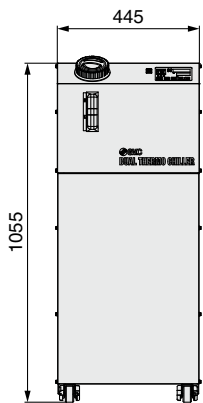

## Parts Description

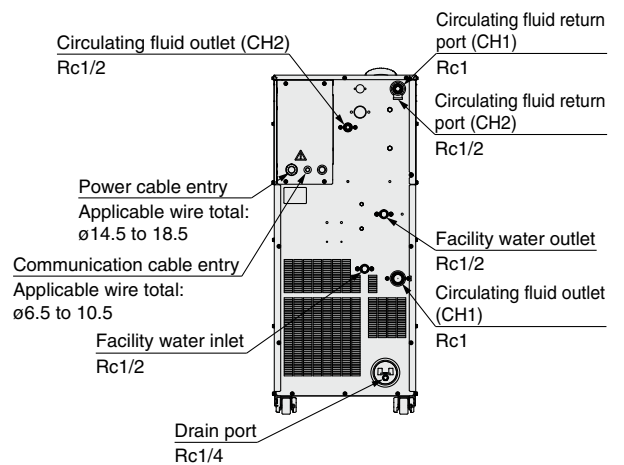
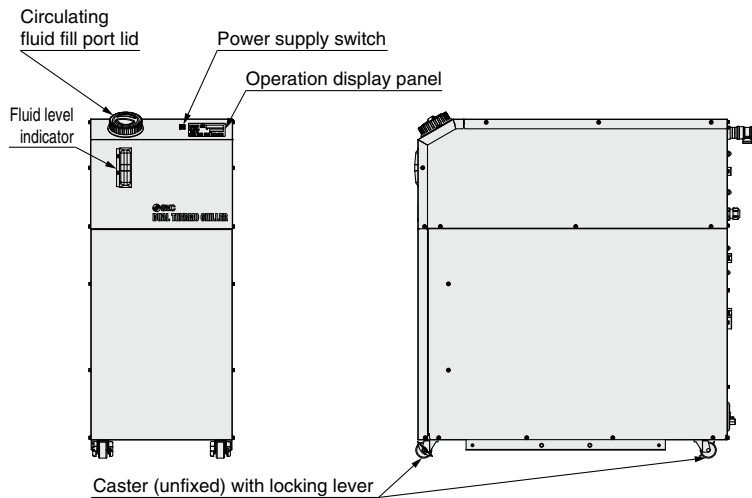
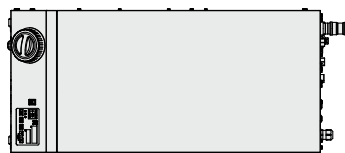

## Recommended External Piping Flow

External piping circuit is recommended as shown below.

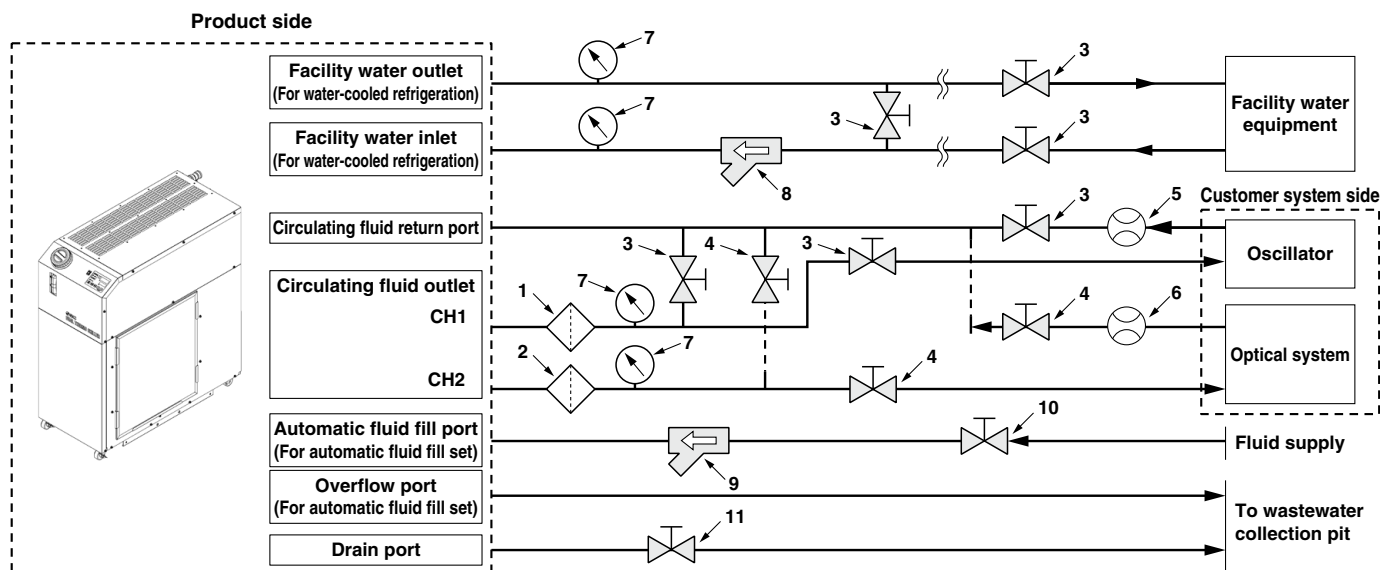

No.	Description	Size	090	050	Note
1	Filter	Rc1 (5 μF)	●	●	The value in ( ) shows the nominal filtration accuracy.
		Rc1/2 (5 μF)	●	●	The value in ( ) shows the nominal filtration accuracy.
2	Filter	Rc1/2 (5 μF)	●	●	—
3	Valve	Rc1	●	●	—
		Rc1/2	●	●	—
4	Valve	Rc1/2	●	●	—
		Rc1	●	●	—
5	Flow meter	Rc1	●	●	Prepare a flow meter with an appropriate flow range.
		Rc1/2	●	●	—
6	Flow meter	Rc1/2	●	●	Prepare a flow meter with an appropriate flow range.
		Rc1	●	●	—
7	Pressure gauge	0 to 1.0 MPa	●	●	—

No.	Description	Size	090	050	Note
8	Y-strainer	Rc1/2 #40	●	●	Install either the strainer or filter. If foreign matter with a size of 20 μm or more are likely to enter, select the particle filter, and then prepare it.
	Filter	Rc1/2 20 μm	●	●	
9	Y-strainer	Rc3/8 #40	●	●	Install either the strainer or filter. If foreign matter with a size of 20 μm or more are likely to enter, select the particle filter, and then prepare it.
	Filter	Rc3/8 20 μm	●	●	
10	Valve	Rc3/8	●	●	—
11	Valve (Part of thermo-chiller)	Rc1/4	●	●	—

## Cable Specifications

### Power Supply Cable and Earth Leakage Breaker (Recommended)

Model	Power supply voltage specifications	Terminal block screw diameter	Recommended crimped terminal	Cable specifications	Earth leakage breaker	
					Breaker size [A]	Sensitivity current [mA]
HRLE050-□-20	Single-phase 200 to 230 VAC (50/60 Hz)	M5	R5.5-5	3 cores x 5.5 mm <sup>2</sup> (3 cores x AWG10) Including grounding cable	30	30
HRLE090-□-20	3-phase 200 VAC (50 Hz) 3-phase 200 to 230 VAC (60 Hz)	M5	R5.5-5	4 cores x 5.5 mm <sup>2</sup> (4 cores x AWG10) Including grounding cable	30	
HRLE090-□-40	3-phase 380 to 415 VAC (50/60 Hz) 3-phase 460 to 480 VAC (60 Hz)	M8	R5.5-8	4 cores x 5.5 mm <sup>2</sup> (4 cores x AWG10) Including grounding cable	20	

\* An example of the cable specifications is when two kinds of vinyl insulated wires with a continuous allowable operating temperature of 70°C at 600 V, are used at an ambient temperature of 30°C. Select the proper size of cable according to an actual condition.

### Communication Cable Specifications

Terminal specifications		Cable specifications
Terminal block screw diameter	Recommended crimped terminal	
M4	Y-shape crimped terminal 0.3Y-4N	0.3 mm <sup>2</sup> (AWG22) Shielded cable

## Function of Each Part

Description	Function
Power supply switch	Power ON/OFF of the product
Operation display panel	Runs and stops the product and performs settings such as for the circulating fluid temperature For details, refer to the "Operation Display Panel" on page 17.
Fluid level indicator	Indicates the circulating fluid level of the tank. Confirm the level is between "H" and "L."
Product label	Shows the product information such as model number and serial number
Circulating fluid outlet	The circulating fluid is discharged from the outlet port.
Circulating fluid return port	The circulating fluid returns to the return port.
Drain port	This drain port is for draining the circulating fluid in the tank and pump.
Dustproof filter	Inserted to prevent dust or contamination from getting directly on the air-cooled condensers. Clean the filter periodically.
Power cable entry	Insert the power cable into the power cable entry and connect it to the breaker.
Communication cable entry	Insert the communication cable into the communication cable entry and connect it to the communication terminal.
Communication terminal	
Facility water inlet (For water-cooled refrigeration)	Supply facility water to inlet port.
Facility water outlet (For water-cooled refrigeration)	Facility water out from outlet port and return to customer's facility water system.

## Operation Display Panel

The basic operation of this unit is controlled through the operation panel on the front of the product.

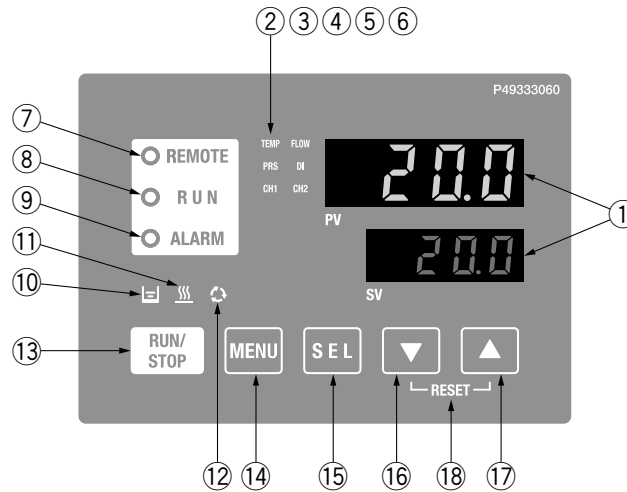

No.	Item	Function	
①	Digital display (7 segments, 4 digits)	PV (Upper line)	Displays the circulating fluid current discharge temperature and pressure and alarm codes and other menu items (codes)
		SV (Lower line)	Displays the circulating fluid discharge temperature and the set values of other menus
②	[TEMP] lamp	Turns ON when the temperature is indicated by ①. The indicated value is in (°C).	
③	[PRS] lamp	Turns ON when the pressure is indicated by ①. The indicated value is in (MPa).	
④	[FLOW] lamp	Not used in this product	
⑤	[DI] lamp	Turns ON when electric conductivity is indicated by ①. The indicated value is in (μS/cm).	
⑥	[CH1/CH2] lamp	Turns ON the CH that is digitally displayed	
⑦	[REMOTE] lamp	Enables remote operation (start and stop) by communication. Turns ON when operation mode is set to DIO or SERIAL	
⑧	[RUN] lamp	Turns ON when the product is started and in operation. Turns OFF when the product is stopped. Blinks during stand-by for stop or during anti-freezing operation	
⑨	[ALARM] lamp	Blinks with an alarm sound if an alarm should occur	
⑩	[L] lamp	Lights up when the surface of the fluid level indicator falls below the L level	
⑪	[A] lamp	Turns ON when the anti-freezing function is enabled. The [RUN] lamp ⑧ blinks during anti-freezing operation.	
⑫	[R] lamp	Not used in this product	
⑬	[RUN/STOP] key	Makes the product start or stop	
⑭	[MENU] key	Shifts the main menu (display screen of circulating fluid discharge temperature and pressure) and other menus (for monitoring and entry of set values)	
⑮	[SEL] key	Changes the item in menu and enters the set value	
⑯	[▼] key	Decreases the set value	
⑰	[▲] key	Increases the set value	
⑱	[RESET] key	Press the [▼] and [▲] keys simultaneously. The alarm sound is stopped and the [ALARM] lamp is reset.	

## Alarm

Alarm code	Explanation
AL01	Low level in tank
AL02	CH1 High circulating fluid temp.
AL05	High circulating fluid return temp.
AL06	High circulating fluid discharge pressure
AL08	Circulating fluid discharge pressure rise
AL09	Circulating fluid discharge pressure drop
AL11	Low compressor suction temp.
AL13	Abnormal high-side refrigerant pressure rise
AL15	Refrigerant leakage
AL16	Abnormal low-side refrigerant pressure rise
AL17	Abnormal low-side refrigerant pressure drop
AL18	Compressor running failure
AL19	Communication error
AL22	CH1 Circulating fluid discharge temp. sensor failure
AL23	Circulating fluid return temp. sensor failure
AL24	Compressor suction temp. sensor failure

Alarm code	Explanation
AL25	Circulating fluid discharge pressure sensor failure
AL26	Refrigerant circuit high pressure sensor failure
AL27	Refrigerant circuit low pressure sensor failure
AL31	Contact input 1 signal detection
AL32	Contact input 2 signal detection
AL34	Electric conductivity rise*3
AL35	Electric conductivity decrease*3
AL36	Electric conductivity sensor failure*3
AL37	Compressor discharge temp. sensor failure
AL38	Compressor discharge temp. rise
AL43	Fan failure*4
AL46	Compressor inverter error*1
AL47	Pump running failure
AL48	Pump inverter error*2
AL50	CH2 Circulating fluid temp. is too high
AL51	CH2 Circulating fluid discharge temp. sensor failure

Alarm code	Explanation
AL52	Memory error 1
AL53	Memory error 2
AL56	Abnormal missing-phase/anti-phase
AL57	Compressor inverter communication error*1
AL58	Pump inverter parameter error*2
AL59	Pump inverter communication error*2
AL62	Internal communication error
AL63	Abnormal high-side refrigerant pressure rise
AL64	Power supply failure
AL65	Refrigerant high pressure switch operated
AL66	Compressor inverter parameter error*1

\*1 Option C only

\*2 Option P only

\*3 Occurs only when the electric conductivity control function is enabled

\*4 Not generated for the water-cooled type

\* For details, read the Operation Manual.



## Communication Functions

### Contact Input/Output

Item	Specifications	
<b>Connector type</b>	M4 terminal block	
<b>Input signal</b>	<b>Insulation method</b>	Photo coupler
	<b>Rated input voltage</b>	24 VDC
	<b>Operating voltage range</b>	21.6 to 26.4 VDC
	<b>Rated input current</b>	5 mA TYP
	<b>Input impedance</b>	4.7 kΩ
<b>Contact output signal</b>	<b>Rated load voltage</b>	48 VAC or less/30 VDC or less
	<b>Max. load current</b>	500 mA AC/DC (Resistance load)
	<b>Min. load current</b>	5 VDC 10 mA
<b>Output voltage</b>	24 VDC ±10% 200 mA MAX (No inductive load)	
<b>Circuit diagram</b>	<p>The diagram shows an M4 terminal block with 16 pins. Pins 1-4 are for contact input signals. Pins 5-7 are for RS-485 communication (SD+, SD-, SG). Pins 9-14 are for contact output signals. Pins 15-16 are for 24 VDC and 24 COM outputs. Internal circuitry includes photo couplers, resistors (1 kΩ, 4.7 kΩ), and relays.</p>	

\*1 The pin numbers and output signals can be set by the customer. For details, refer to the Operation Manual for communication.

\*2 When using with optional accessories, depending on the accessory, the allowable current of 24 VDC devices will be reduced. Refer to the Operation Manual of the optional accessories for details.

### Serial Communication

The serial communication (RS-485) enables the following items to be written and read out.

For details, refer to the Operation Manual for communication.

#### Writing

Run/Stop  
Circulating fluid temperature setting (SV)

#### Readout

Circulating fluid present temperature  
Circulating fluid discharge pressure  
Status information  
Alarm occurrence information

Item	Specifications
<b>Connector type</b>	M4 terminal block
<b>Protocol</b>	Modicon Modbus compliant/Simple communication protocol
<b>Standards</b>	EIA standard RS-485
<b>Circuit diagram</b>	<p>The diagram shows the internal circuitry for RS-485 communication. It includes a photo coupler and resistors connected to pins 5 (SD+), 6 (SD-), and 7 (SG).</p>

\* The terminal resistance of RS-485 (120 Ω) can be switched by the operation display panel. For details, refer to the Operation Manual for communication. Do not connect other than in the way shown above, as it can result in failure.

Please download the Operation Manual via our website: <https://www.smcworld.com>

# HRLE Series Options

**C** Option symbol

## With Inverter for Compressor

HRLE090-□-□-**C**

● With inverter for compressor

The inverter for compressor increases the cooling capacity of the 50 Hz area to that of the 60 Hz area. (Refer to the 60 Hz graph under “Cooling Capacity” on page 13.)

\* No change in external dimensions

**M** Option symbol

## Deionized Water (Pure Water) Piping

HRLE □-□-□-**M**

● Deionized water (Pure water) piping

The contact materials of the circulating fluid circuit are made from non-copper materials.

Applicable model	<b>HRLE050-□-□-M/HRLE090-□-□-M</b>
Contact materials of circulating fluid	Stainless steel (including heat exchanger brazing), SiC, Carbon, PA, PP, PE, POM, FKM, EPDM, PVC, PTFE

\* No change in external dimensions

**P** Option symbol

## With Inverter for Pump

HRLE090-□-□-**P**

● With inverter for pump

The inverter for pump increases the pump capacity of the 50 Hz area to that of the 60 Hz area.

Pressure setting is also available, allowing for auto control to any pressure without the need for valve position adjustments.

\* No change in external dimensions

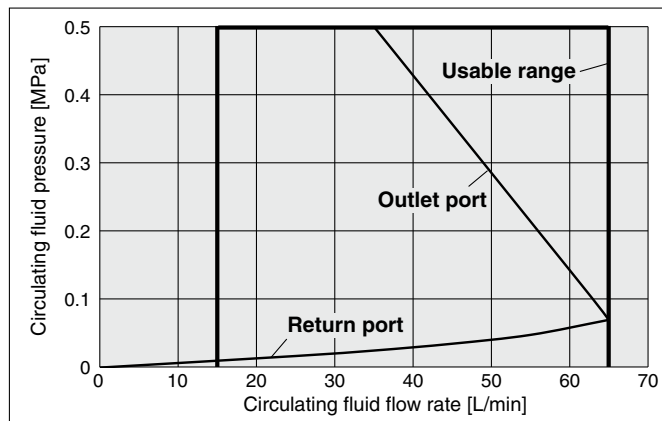

\* The pump capacity is the capacity of CH1 when 2 L/min are applied to CH2.

# HRLE Series

## Optional Accessories

### ① Piping Conversion Fitting

This is a fitting to change the port from Rc to G or NPT.

Part no.	Description	Applicable model	Circulating fluid inlet/outlet		Facility water inlet/outlet * For the water-cooled type	Drain port
			CH1	CH2		
<b>HRL-EP007</b>	G thread conversion fitting set	<b>HRLE050-A-□</b>	G1/2	G1/2	—	G1/4
<b>HRL-EP008</b>	NPT thread conversion fitting set		NPT1/2	NPT1/2		NPT1/4
<b>HRL-EP009</b>	G thread conversion fitting set	<b>HRLE050-W-□</b>	G1/2	G1/2	G1/2	G1/4
<b>HRL-EP010</b>	NPT thread conversion fitting set		NPT1/2	NPT1/2	NPT1/2	NPT1/4
<b>HRL-EP003</b>	G thread conversion fitting set	<b>HRLE090-A-□</b>	G1	G1/2	—	G1/4
<b>HRL-EP004</b>	NPT thread conversion fitting set		NPT1	NPT1/2		NPT1/4
<b>HRL-EP005</b>	G thread conversion fitting set	<b>HRLE090-W-□</b>	G1	G1/2	G1/2	G1/4
<b>HRL-EP006</b>	NPT thread conversion fitting set		NPT1	NPT1/2	NPT1/2	NPT1/4

When the fitting is required in conjunction with the automatic fluid fill set (accessory sold separately), purchase the following.

Part no.	Description	Applicable model	Circulating fluid inlet/outlet		Facility water inlet/outlet * For the water-cooled type	Drain port	Automatic fluid fill port	Overflow port
			CH1	CH2				
<b>HRL-EP015</b>	G thread conversion fitting set	<b>HRLE050-A-□ +HRL-JK001</b>	G1/2	G1/2	—	G1/4	G3/8	G3/4
<b>HRL-EP016</b>	NPT thread conversion fitting set		NPT1/2	NPT1/2		NPT1/4	NPT3/8	NPT3/4
<b>HRL-EP017</b>	G thread conversion fitting set	<b>HRLE050-W-□ +HRL-JK001</b>	G1/2	G1/2	G1/2	G1/4	G3/8	G3/4
<b>HRL-EP018</b>	NPT thread conversion fitting set		NPT1/2	NPT1/2	NPT1/2	NPT1/4	NPT3/8	NPT3/4
<b>HRL-EP011</b>	G thread conversion fitting set	<b>HRLE090-A-□ +HRL-JK001</b>	G1	G1/2	—	G1/4	G3/8	G3/4
<b>HRL-EP012</b>	NPT thread conversion fitting set		NPT1	NPT1/2		NPT1/4	NPT3/8	NPT3/4
<b>HRL-EP013</b>	G thread conversion fitting set	<b>HRLE090-W-□ +HRL-JK001</b>	G1	G1/2	G1/2	G1/4	G3/8	G3/4
<b>HRL-EP014</b>	NPT thread conversion fitting set		NPT1	NPT1/2	NPT1/2	NPT1/4	NPT3/8	NPT3/4

# HRLE Series

## ② Bypass Piping Set

When the circulating fluid goes below the min. operating flow rate (as shown below), cooling capacity will be reduced and the temperature stability will be badly affected. Use the bypass piping set to ensure a circulating fluid flow rate of the min. operating flow rate or more.

Part no.	Applicable model	Min. operating flow rate [L/min]
HRL-BP002	HRLE050-□-□	CH1: 15/15 (50/60 Hz)
		CH2: 1/1 (50/60 Hz)
HRL-BP001	HRLE090-□-□	CH1: 25/35 (50/60 Hz)
		CH2: 1/1 (50/60 Hz)

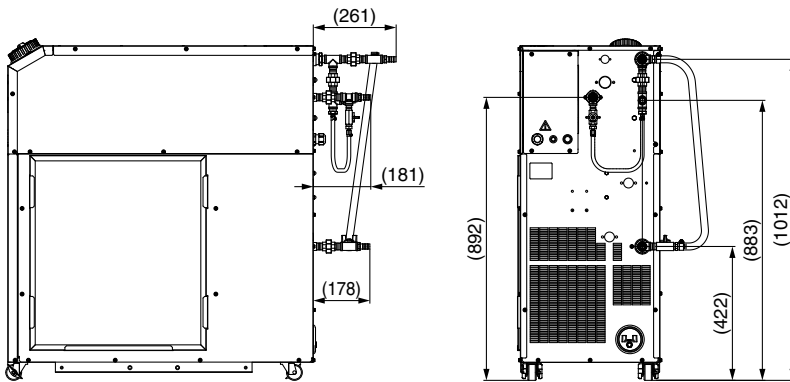
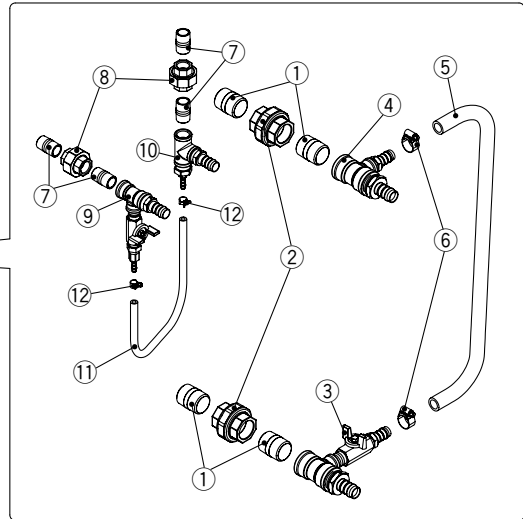
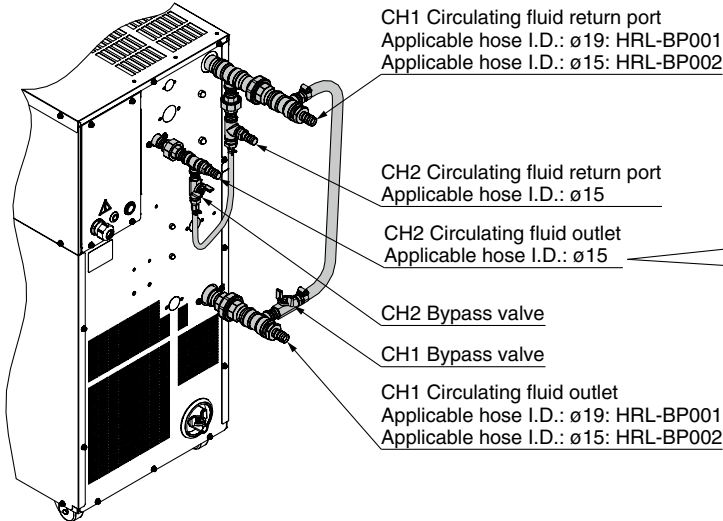

Mounting dimensions: HRLE050

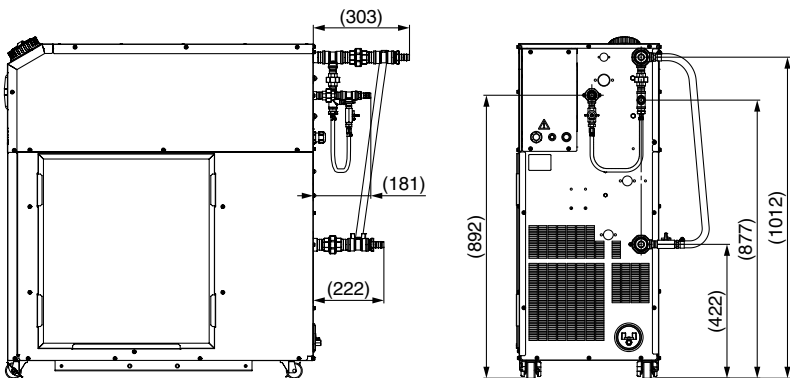

Mounting dimensions: HRLE090

### Parts List

No.	Description	Fluid contact material	Qty.
①	Nipple (Size: 1 inch...HRL-BP001 : 1/2 inch...HRL-BP002)	Stainless steel	4
②	Union (Size: 1 inch...HRL-BP001 : 1/2 inch...HRL-BP002)	Stainless steel	2
③	CH1 Outlet piping assembly (Applicable hose I.D.: ø19...HRL-BP001 : ø15...HRL-BP002)	Stainless steel, PA	1
④	CH1 Return piping assembly (Applicable hose I.D.: ø19...HRL-BP001 : ø15...HRL-BP002)	Stainless steel, PA	1
⑤	Hose	PVC	1
⑥	Hose band	—	2
⑦	Nipple (Size: 1 inch...HRL-BP001 : 1/2 inch...HRL-BP002)	Stainless steel	4
⑧	Union (Size: 1 inch...HRL-BP001 : 1/2 inch...HRL-BP002)	Stainless steel	2
⑨	CH2 Outlet piping assembly (Applicable hose I.D.: ø19...HRL-BP001 : ø15...HRL-BP002)	Stainless steel, PA	1
⑩	CH2 Return piping assembly (Applicable hose I.D.: ø19...HRL-BP001 : ø15...HRL-BP002)	Stainless steel, PA	1
⑪	Hose	PVC	1
⑫	Hose clamp	—	2
⑬	Sealant tape	PTFE	1



# HRLE Series

## ③ Electric Conductivity Control Set

This set can be used to display and control the electric conductivity of the circulating fluid. Refer to the Operation Manual for details.

Part no.	Applicable model
HRL-DI002	HRLE050-□-□
HRL-DI001	HRLE090-□-□

Measurement range of electric conductivity	2.0 to 48.0 $\mu\text{S/cm}$
Set range of target electric conductivity	0.5 to 45.0 $\mu\text{S/cm}$
Set range of electric conductivity hysteresis	0.1 to 10.0 $\mu\text{S/cm}$
Operating temperature range (Circulating fluid temperature)	5 to 60°C
Power consumption	400 mA or less

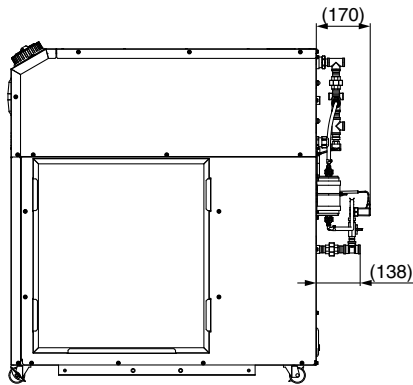
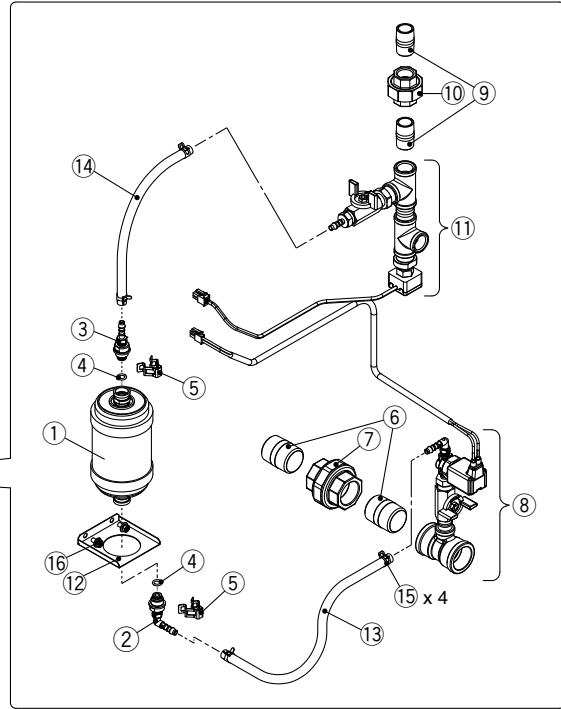
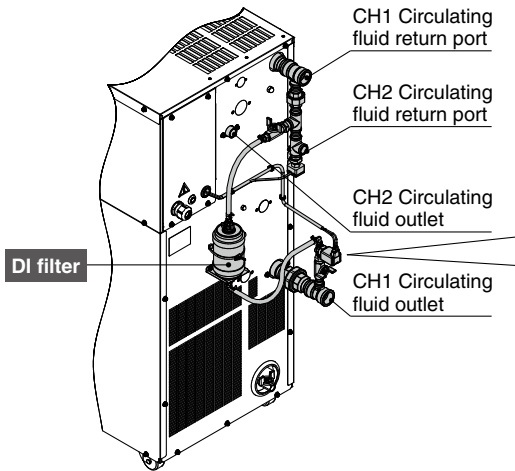

Mounting dimensions: HRLE050

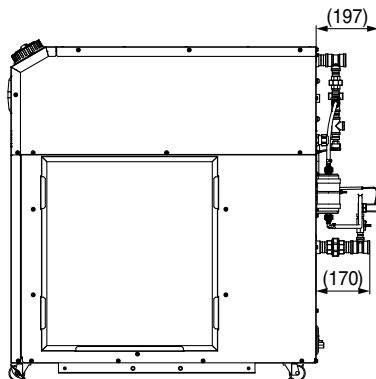

Mounting dimensions: HRLE090

### Parts List

No.	Description	Fluid contact material	Qty.
①	DI filter cartridge (Part no.: HRR-DF001)*1	PP, PE	1
②	DI filter inlet fitting assembly	Stainless steel, PA	1
③	DI filter outlet fitting assembly	Stainless steel, PA	1
④	O-ring	EPDM	2
⑤	Clip	—	2
⑥	Nipple (Size: 1 inch...HRL-DI001) : 1/2 inch...HRL-DI002)	Stainless steel	2
⑦	Union (Size: 1 inch...HRL-DI001) : 1/2 inch...HRL-DI002)	Stainless steel	1
⑧	DI control piping assembly	Stainless steel	1
⑨	Nipple (Size: 1/2 inch)	Stainless steel	2
⑩	Union (Size: 1/2 inch)	Stainless steel	1
⑪	DI sensor piping assembly	Stainless steel	1
⑫	Mounting bracket	—	1
⑬	DI filter inlet hose	PVC	1
⑭	DI filter outlet hose	PVC	1
⑮	Hose clamp	—	4
⑯	Mounting screw (Size: M5)	—	2
⑰	Cable tie holder	—	5
⑱	Binding band	—	4
⑲	Reusable band	—	1
⑳	Sealant tape	PTFE	1
㉑	DI control solenoid valve extension cable	—	1

\*1 The product should be replaced when it can no longer preserve the electrical conductivity set value.

#### ④ Particle Filter Set

This set can be used to remove foreign matter from the circulating fluid. If foreign matter such as scales in the piping enter the circulating fluid, this may cause the pump to malfunction. Therefore, it is strongly recommended to install the particle filter set. This set cannot be directly connected to the thermo-chiller. Install it in the customer's piping system. For details, refer to the Operation Manual.

#### ■ Particle filter set (For HRLE090, CH1)

##### HRL-PF001

Fluid	Tap water
Max. operating pressure	0.65 MPa
Operating temperature range	5 to 35°C
Nominal filtration accuracy	5 μm
Installation environment	Indoors

##### Parts List

No.	Description	Material	Qty.	Note
①	Body	PC, PP	1	—
②	Element	PP	1	—
③	Conversion nipple	Stainless steel	2	Conversion from NPT to Rc
④	Conversion fitting	Stainless steel	2	Conversion from NPT to Rc
⑤	Sealant tape	PTFE	1	—

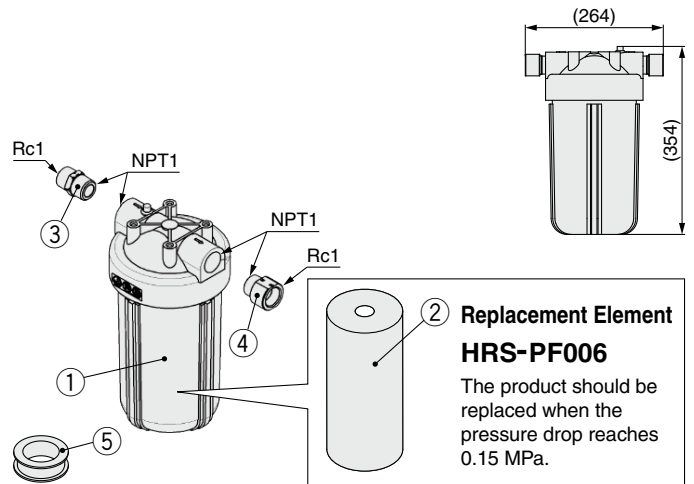

\* If a handle is required, please order it separately.  
Handle: HRS-S0600

#### ■ Particle filter set (For HRLE050, CH1/CH2) (For HRLE090, CH2)

This set can be used to remove foreign matter from the circulating fluid.

##### HRL-PF002

Fluid	Tap water
Max. operating pressure	0.65 MPa
Operating temperature range	5 to 35°C
Nominal filtration accuracy	5 μm
Installation environment	Indoors

##### Parts List

No.	Description	Material	Qty.	Note
①	Body	PP	1	—
②	Element	PP, PE	1	—
③	Conversion nipple	Stainless steel	2	—
④	Conversion fitting	Stainless steel	2	—
⑤	Sealant tape	PTFE	1	—

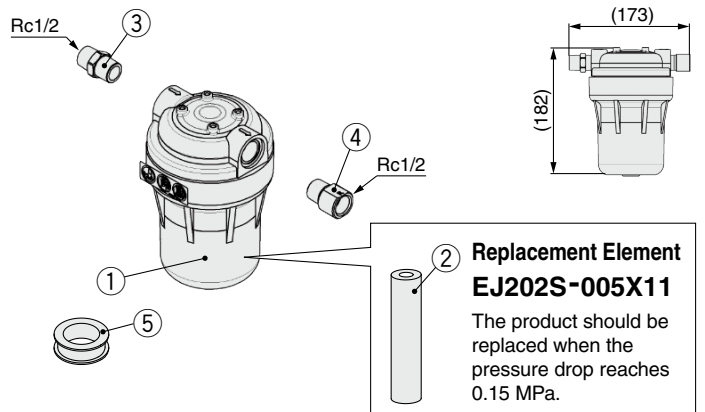

\* If a handle is required, please order it separately.  
Handle: HRR-S0079

# HRLE Series

## ⑤ Filter for Circulating Fluid Fill Port

Prevents foreign matter from entering the tank when supplying the circulating fluid. Can be used just by fitting into the circulating fluid fill port.

### ■ Filter for circulating fluid fill port HRS-PF007

Material	Stainless steel 304, Stainless steel 316
Mesh size	200

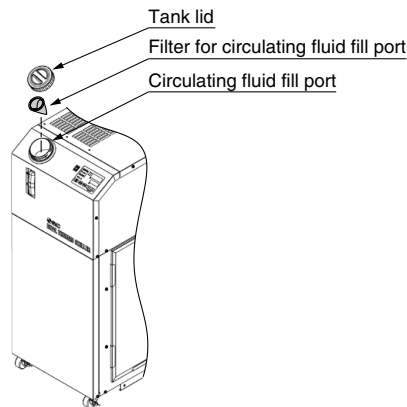

## ⑥ Automatic Fluid Fill Set

By installing this at the automatic fluid fill port, the circulating fluid can be automatically supplied to the product while the circulating fluid is decreasing.

Part no.	Applicable model
HRL-JK001	<b>HRLE050</b> -□-□ <b>HRLE090</b> -□-□

Fluid fill pressure [MPa]	0.2 to 0.5
Feed water temperature [°C]	15 to 25
Fluid fill method	Ball tap

### Parts List

No.	Description	Material	Qty.	Note
①	Overflow port assembly		1	
②	Automatic fluid fill assembly		1	
③	Automatic fluid fill tank assembly	PE	1	
④	M4 screw	—	2	For securing automatic fluid fill assembly
⑤	M6 screw	—	2	For securing overflow port assembly
⑥	Hose clamp	—	1	For securing automatic fluid fill assembly hose
⑦	Hose clamp	—	1	For securing overflow port assembly hose
⑧	Automatic fluid fill label	—	1	

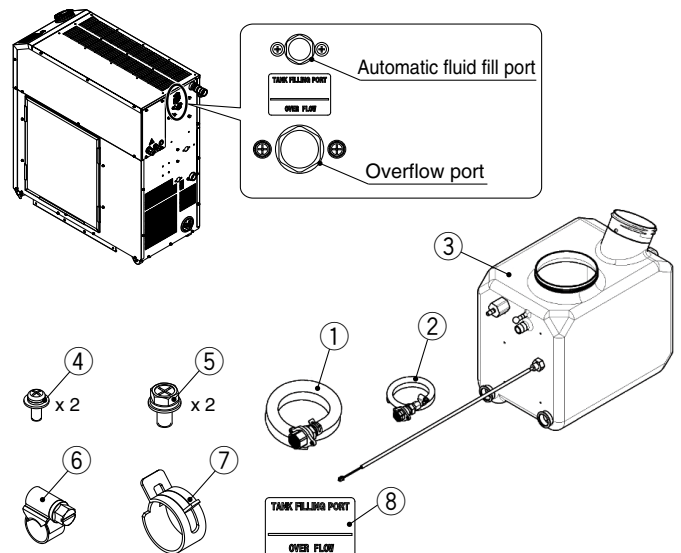

## ⑦ Ball Valve Set (With Pressure Gauge)

This is a set of fittings including a ball valve and a pressure gauge to be used when adjusting the circulating fluid discharge pressure and flow rate at the chiller.

Part no.	Applicable model
HRL-BB002	<b>HRLE050</b> -□-□
HRL-BB001	<b>HRLE090</b> -□-□

### Parts List

No.	Description	Material	Applicable model	Size	Qty.	Note
①	Nipple	Stainless steel	HRLE090	R1	2	For CH1
			HRLE050	R1/2		
②	Ball valve	Stainless steel	HRLE090	Rc1	1	For CH1
			HRLE050	Rc1/2		
③	Different diameter tee	Stainless steel	HRLE090	Rc1 x Rc3/8	1	For CH1
			HRLE050	Rc1/2 x Rc3/8		
④	Hexagon bushing	Stainless steel	HRLE090/050	Rc3/8 x Rc1/4	2	For CH1/CH2
⑤	Pressure gauge	—	HRLE090/050	R1/4	2	For CH1/CH2
⑥	Nipple	Stainless steel	HRLE090/050	R1/2	2	For CH2
⑦	Ball valve	Stainless steel	HRLE090/050	Rc1/2	1	For CH2
⑧	Different diameter tee	Stainless steel	HRLE090/050	Rc1/2 x Rc3/8	1	For CH2
⑨	Sealant tape	PTFE	HRLE090/050	—	1	

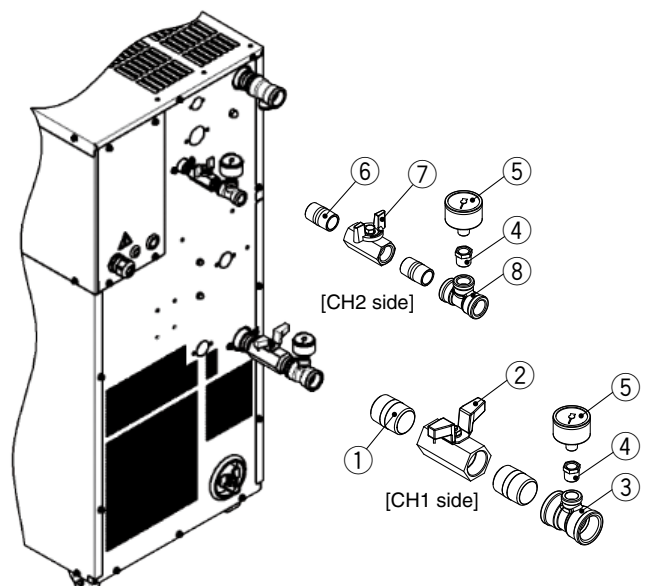



# Cooling Capacity Calculation

## Required Cooling Capacity Calculation

**Example 1: When the heat generation amount in the customer equipment is known.**

The heat generation amount can be determined based on the power consumption or output of the heat generating area — i.e. the area requiring cooling — within the customer equipment.\*1

- ① Derive the heat generation amount from the power consumption.

Power consumption P: 7 [kW]

$$Q = P = 7 \text{ [kW]}$$

Cooling capacity = Considering a safety factor of 20%,  $7 \text{ [kW]} \times 1.2 = \boxed{8.4 \text{ [kW]}}$

- ③ Derive the heat generation amount from the output. Output (shaft power, etc.) W: 5.1 [kW]

$$Q = P = \frac{W}{\text{Efficiency}}$$

In this example, using an efficiency of 0.7:

$$= \frac{5.1}{0.7} = 7.3 \text{ [kW]}$$

Cooling capacity = Considering a safety factor of 20%,  $7.3 \text{ [kW]} \times 1.2 = \boxed{8.8 \text{ [kW]}}$

- ② Derive the heat generation amount from the power supply output.

Power supply output VI: 8.8 [kVA]

$$Q = P = V \times I \times \text{Power factor}$$

In this example, using a power factor of 0.85:

$$= 8.8 \text{ [kVA]} \times 0.85 = 7.5 \text{ [kW]}$$

Cooling capacity = Considering a safety factor of 20%,  $7.5 \text{ [kW]} \times 1.2 = \boxed{9.0 \text{ [kW]}}$

- ④ Calculate based on the laser output.

Laser output power 3 [kW], conversion efficiency 30%

The oscillator's power consumption is,  $3 \text{ [kW]} \div 0.3 = 10 \text{ [kW]}$

The cooling capacity required for the oscillator is,  $10 \text{ [kW]} - 3 \text{ [kW]} = 7 \text{ [kW]}$

Considering a safety factor of 20%,  $7 \text{ [kW]} \times 1.2 = \boxed{8.4 \text{ [kW]}}$

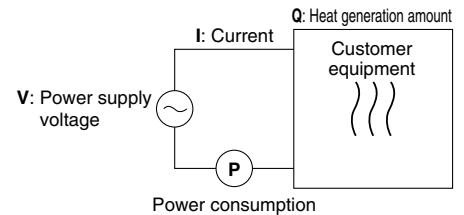

\*1 The examples above calculate the heat generation amount based on the power consumption. The actual heat generation amount may differ due to the structure of the customer equipment. Be sure to check it carefully.

**Example 2: When the heat generation amount in the customer equipment is not known.**

Obtain the temperature difference between inlet and outlet by circulating the circulating fluid inside the customer equipment.

Heat generation amount by customer equipment **Q** : Unknown [W] ((J/s))  
 Circulating fluid : Tap water\*1  
 Circulating fluid mass flow rate **qm** : (=  $\rho \times qv \div 60$ ) [kg/s]  
 Circulating fluid density  $\rho$  : 1 [kg/L]  
 Circulating fluid (volume) flow rate **qv** : 35 [L/min]  
 Circulating fluid specific heat **C** :  $4.186 \times 10^3$  [J/(kg·K)]  
 Circulating fluid outlet temperature **T1** : 293 [K] (20 [°C])  
 Circulating fluid return temperature **T2** : 296 [K] (23 [°C])  
 Circulating fluid temperature difference  $\Delta T$  : 3 [K] (=  $T_2 - T_1$ )  
 Conversion factor: minutes to seconds (SI units) : 60 [s/min]

\*1 Refer to page 25 for the typical physical property value of tap water or other circulating fluids.

$$Q = qm \times C \times (T_2 - T_1)$$

$$= \frac{\rho \times qv \times C \times \Delta T}{60} = \frac{1 \times 35 \times 4.186 \times 10^3 \times 3.0}{60}$$

$$= 7325 \text{ [J/s]} \approx 7325 \text{ [W]} = 7.3 \text{ [kW]}$$

Cooling capacity = Considering a safety factor of 20%,  
 $7.3 \text{ [kW]} \times 1.2 = \boxed{8.8 \text{ [kW]}}$

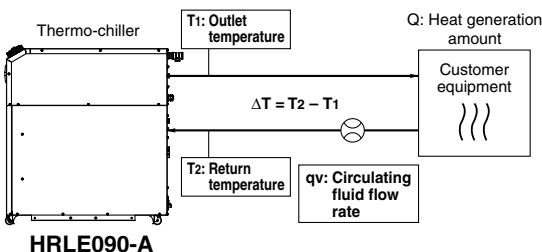

HRLE090-A

### Example of conventional units (Reference)

Heat generation amount by customer equipment **Q** : Unknown [cal/h] → [W]  
 Circulating fluid : Tap water\*1  
 Circulating fluid weight flow rate **qm** : (=  $\rho \times qv \times 60$ ) [kgf/h]  
 Circulating fluid weight volume ratio  $\gamma$  : 1 [kgf/L]  
 Circulating fluid (volume) flow rate **qv** : 35 [L/min]  
 Circulating fluid specific heat **C** :  $1.0 \times 10^3$  [cal/(kgf·°C)]  
 Circulating fluid outlet temperature **T1** : 20 [°C]  
 Circulating fluid return temperature **T2** : 23 [°C]  
 Circulating fluid temperature difference  $\Delta T$  : 3 [°C] (=  $T_2 - T_1$ )  
 Conversion factor: hours to minutes : 60 [min/h]  
 Conversion factor: kcal/h to kW : 860 [(cal/h)/W]

$$Q = \frac{qm \times C \times (T_2 - T_1)}{860}$$

$$= \frac{\gamma \times qv \times 60 \times C \times \Delta T}{860}$$

$$= \frac{1 \times 35 \times 60 \times 1.0 \times 10^3 \times 3.0}{860}$$

$$\approx 7325 \text{ [W]} = 7.3 \text{ [kW]}$$

Cooling capacity = Considering a safety factor of 20%,  
 $7.3 \text{ [kW]} \times 1.2 = \boxed{8.8 \text{ [kW]}}$

## Required Cooling Capacity Calculation

**Example 3: When there is no heat generation, and when cooling the object below a certain temperature and period of time.**

Heat quantity by cooled substance (per unit time) **Q** : Unknown [W] ([J/s])  
 Cooled substance : Water  
 Cooled substance mass **m** : (=  $\rho \times V$ ) [kg]  
 Cooled substance density  $\rho$  : 1 [kg/L]  
 Cooled substance total volume **V** : 150 [L]  
 Cooled substance specific heat **C** :  $4.186 \times 10^3$  [J/(kg·K)]  
 Cooled substance temperature when cooling begins **T<sub>0</sub>** : 303 [K] (30 [°C])  
 Cooled substance temperature after t hour **T<sub>t</sub>** : 293 [K] (20 [°C])  
 Cooling temperature difference  $\Delta T$  : 10 [K] (=  $T_0 - T_t$ )  
 Cooling time  $\Delta t$  : 900 [s] (= 15 [min])

\* Refer to the following for the typical physical property values by circulating fluid.

$$Q = \frac{m \times C \times (T_0 - T_t)}{\Delta t} = \frac{\rho \times V \times C \times \Delta T}{\Delta t}$$

$$= \frac{1 \times 150 \times 4.186 \times 10^3 \times 10}{900} = 6977 \text{ [J/s]} \approx 7.0 \text{ [kW]}$$

Cooling capacity = Considering a safety factor of 20%,  
 $7.0 \text{ [kW]} \times 1.2 = \mathbf{8.4 \text{ [kW]}}$

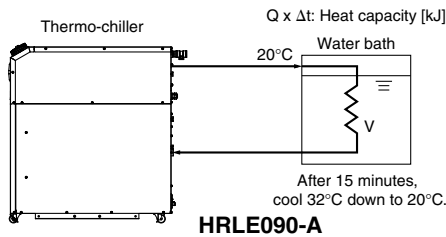

### Example of conventional units (Reference)

Heat quantity by cooled substance (per unit time) **Q** : Unknown [cal/h] → [W]  
 Cooled substance : Water  
 Cooled substance weight **m** : (=  $\rho \times V$ ) [kgf]  
 Cooled substance weight volume ratio  $\gamma$  : 1 [kgf/L]  
 Cooled substance total volume **V** : 150 [L]  
 Cooled substance specific heat **C** :  $1.0 \times 10^3$  [cal/(kgf·°C)]  
 Cooled substance temperature when cooling begins **T<sub>0</sub>** : 30 [°C]  
 Cooled substance temperature after t hour **T<sub>t</sub>** : 20 [°C]  
 Cooling temperature difference  $\Delta T$  : 10 [°C] (=  $T_0 - T_t$ )  
 Cooling time  $\Delta t$  : 15 [min]  
 Conversion factor: hours to minutes : 60 [min/h]  
 Conversion factor: kcal/h to kW : 860 [(cal/h)/W]

$$Q = \frac{m \times C \times (T_0 - T_t)}{\Delta t \times 860} = \frac{\gamma \times V \times 60 \times C \times \Delta T}{\Delta t \times 860}$$

$$= \frac{1 \times 150 \times 60 \times 1.0 \times 10^3 \times 10}{15 \times 860}$$

$$\approx 6977 \text{ [W]} = 7.0 \text{ [kW]}$$

Cooling capacity = Considering a safety factor of 20%,  
 $7.0 \text{ [kW]} \times 1.2 = \mathbf{8.4 \text{ [kW]}}$

\* This is the calculated value by changing the fluid temperature only. Thus, it varies substantially depending on the water bath or piping shape.

## Precautions on Cooling Capacity Calculation

### 1. Heating capacity

When the circulating fluid temperature is set above room temperature, it needs to be heated by the thermo-chiller. The heating capacity depends on the circulating fluid temperature. Consider the radiation rate and heat capacity of the customer equipment and check beforehand if the required heating capacity is provided.

### 2. Pump capacity

#### <Circulating fluid flow rate>

Circulating fluid flow rate varies depending on the circulating fluid discharge pressure. Consider the installation height difference between the thermo-chiller and the customer equipment, and the piping resistance such as circulating fluid pipings, or piping size, or piping curves in the machine. Check beforehand if the required flow is achieved, using the pump capacity curves.

#### <Circulating fluid discharge pressure>

Circulating fluid discharge pressure has the possibility to increase up to the max. pressure in the pump capacity curves.

Check beforehand if the circulating fluid pipings or circulating fluid circuit of the customer equipment are fully durable against this pressure.

## Circulating Fluid Typical Physical Property Values

### 1. This catalog uses the following values for density and specific heat in calculating the required cooling capacity.

Density  $\rho$ : 1 [kg/L] (or, using conventional units, weight volume ratio  $\gamma = 1$  [kgf/L])

Specific heat **C**:  $4.19 \times 10^3$  [J/(kg·K)] (or, using conventional units,  $1 \times 10^3$  [cal/(kgf·°C)])

### 2. Values for density and specific heat change slightly according to temperature shown below. Use this as a reference.

#### Water

Physical property value Temperature	Density $\rho$ [kg/L]	Specific heat C [J/(kg·K)]	Conventional units	
			Weight volume ratio $\gamma$ [kgf/L]	Specific heat C [cal/(kgf·°C)]
5°C	1.00	$4.2 \times 10^3$	1.00	$1 \times 10^3$
10°C	1.00	$4.19 \times 10^3$	1.00	$1 \times 10^3$
15°C	1.00	$4.19 \times 10^3$	1.00	$1 \times 10^3$
20°C	1.00	$4.18 \times 10^3$	1.00	$1 \times 10^3$
25°C	1.00	$4.18 \times 10^3$	1.00	$1 \times 10^3$
30°C	1.00	$4.18 \times 10^3$	1.00	$1 \times 10^3$
35°C	0.99	$4.18 \times 10^3$	0.99	$1 \times 10^3$
40°C	0.99	$4.18 \times 10^3$	0.99	$1 \times 10^3$

#### 15% Ethylene Glycol Aqueous Solution

Physical property value Temperature	Density $\rho$ [kg/L]	Specific heat C [J/(kg·K)]	Conventional units	
			Weight volume ratio $\gamma$ [kgf/L]	Specific heat C [cal/(kgf·°C)]
5°C	1.02	$3.91 \times 10^3$	1.02	$0.93 \times 10^3$
10°C	1.02	$3.91 \times 10^3$	1.02	$0.93 \times 10^3$
15°C	1.02	$3.91 \times 10^3$	1.02	$0.93 \times 10^3$
20°C	1.01	$3.91 \times 10^3$	1.01	$0.93 \times 10^3$
25°C	1.01	$3.91 \times 10^3$	1.01	$0.93 \times 10^3$
30°C	1.01	$3.91 \times 10^3$	1.01	$0.94 \times 10^3$
35°C	1.01	$3.91 \times 10^3$	1.01	$0.94 \times 10^3$
40°C	1.01	$3.92 \times 10^3$	1.01	$0.94 \times 10^3$

\* Shown above are reference values. Contact circulating fluid supplier for details.



# HRLE Series

## Specific Product Precautions 1

Be sure to read this before handling the products. Refer to the back cover for safety instructions. For temperature control equipment precautions, refer to the “Handling Precautions for SMC Products” and the “Operation Manual” on the SMC website: <https://www.smcworld.com>

### Design

#### Warning

##### 1. This catalog shows the specifications of a single unit.

1. Check the specifications of the single unit (contents of this catalog) and thoroughly consider the adaptability between the customer system and this unit.
2. Although a protection circuit as a single unit is installed, prepare a drain pan, water leakage sensor, discharge air facility, and emergency stop equipment, depending on the customer’s operating conditions. Also, the customer is requested to carry out a safety design for the whole system.

##### 2. When attempting to cool areas that are open to the atmosphere (tanks, pipes), plan your piping system accordingly.

When cooling open-air external tanks, arrange the piping so that there are coil pipes for cooling inside the tanks and to carry back the entire flow volume of circulating fluid that is released.

##### 3. Use non-corrosive materials for circulating fluid contact parts.

The recommended circulating fluid is tap water or deionized (pure) water. Using corrosive materials such as aluminum or iron for fluid contact parts such as piping may cause clogging or leakage in the circulating fluid circuit. Therefore, take sufficient care when selecting fluid contact part materials such as piping.

##### 4. Design the piping so that no foreign matter enters the chiller.

If foreign matter, such as scales in the piping, enters the circulating fluid, this may cause the pump to malfunction. Therefore, it is strongly recommended to install the particle filter.

##### 5. The facility water outlet temperature (water-cooled type) may increase up to around 60°C.

When selecting the facility water pipings, consider the suitability for temperature.

### Selection

#### Warning

##### Model selection

When selecting a thermo-chiller model, the amount of heat generation from the customer equipment must be known. Obtain this value, referring to the “Cooling Capacity Calculation” on pages 24 and 25 before selecting a model.

### Handling

#### Warning

##### Thoroughly read the Operation Manual.

Read the Operation Manual completely before operation, and keep the manual where it can be referred to as necessary.

### Operating Environment / Storage Environment

#### Warning

##### 1. Do not use in the following environment as it will lead to a breakdown.

1. In locations where liquid that exceeds the conditions required for the degrees of protection IPX4 may splash on the product
2. In locations where dust, water vapor, salt water, and oil may splash on the product
3. In locations where there are dust and particles
4. In locations where corrosive gases, organic solvents, chemical fluids, or flammable gases are present (This product is not explosion proof.)
5. In locations where the ambient temperature/humidity exceeds the limits as mentioned below or where condensation occurs  
During transportation/storage: 0°C to 50°C, 15% to 85%  
(But as long as water or circulating fluid are not left inside the pipings)

During operation: 2°C to 45°C, 30% to 70%

6. In locations where condensation may occur
7. In locations which receive direct sunlight or radiated heat
8. In locations where there is a heat source nearby and the ventilation is poor
9. In locations where temperature substantially changes
10. In locations where strong magnetic noise occurs  
(In locations where strong electric fields, strong magnetic fields and surge voltage occur)
11. In locations where static electricity occurs, or conditions which make the product discharge static electricity
12. In locations where high frequency occurs
13. In locations where damage is likely to occur due to lightning
14. In locations at an altitude of 3000 m or higher (Except during storage and transportation)

\* For altitudes of 1000 m or higher

Because of lower air density, the heat radiation efficiencies of the devices in the product will be lower in the location at an altitude of 1000 m or higher. Therefore, the max. ambient temperature to use and the cooling capacity will lower according to the descriptions in the table below.

Select the thermo-chiller considering the descriptions.

- ① Upper limit of ambient temperature: Use the product in ambient temperature of the described value or lower at each altitude.
- ② Cooling capacity coefficient: The product’s cooling capacity will lower to one that multiplied by the described value at each altitude.

Altitude [m]	① Upper limit of ambient temperature [°C]	② Cooling capacity coefficient
Less than 1000 m	45	1.00
Less than 1500 m	42	0.85
Less than 2000 m	38	0.80
Less than 2500 m	35	0.75
Less than 3000 m	32	0.70

15. In locations where strong impacts or vibrations occur
16. In locations where a massive force strong enough to deform the product is applied or a weight from a heavy object is applied
17. In locations where there is not sufficient space for maintenance
18. Bevelled place
19. Insects or plants may enter the unit.

##### 2. The product is not designed for clean room usage. It generates particles internally.



# HRLE Series Specific Product Precautions 2

Be sure to read this before handling the products. Refer to the back cover for safety instructions. For temperature control equipment precautions, refer to the “Handling Precautions for SMC Products” and the “Operation Manual” on the SMC website: <https://www.smcworld.com>

## Transportation / Carriage / Movement

### Warning

1. This product is heavy. Pay attention to safety and the position of the product when it is transported, carried, and moved.
2. Read the Operation Manual carefully before moving the product after unpacking.

### Caution

1. Never put the product down on its side as this may cause a failure.

The product will be delivered in the packaging shown below.

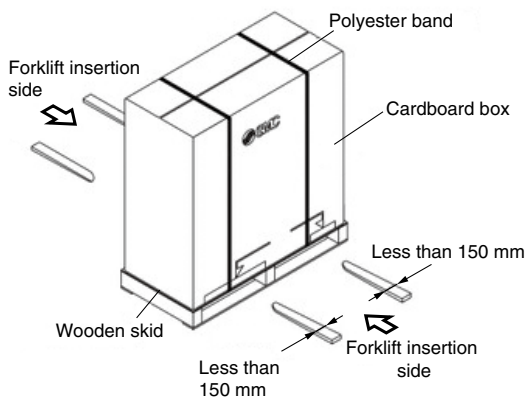

#### <When packaged>

Model	Weight [kg]	Dimensions [mm]
HRLE050-A-20	150	Height 1320 x Width 580 x Depth 1240
HRLE050-W-20	143	
HRLE090-A-20/40	176	
HRLE090-W-20/40	170	

### 2. Transporting with forklift

1. A licensed driver should drive the forklift.
2. Insert the fork to the place specified on the label. The fork should reach through to the other side of the product.
3. Be careful not to bump the fork to the cover panel or piping ports.

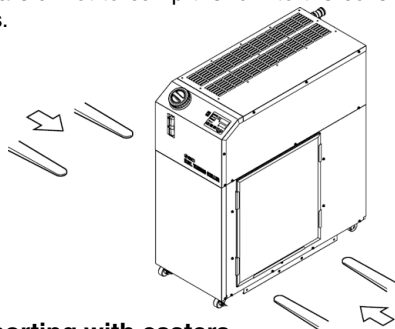

### 3. Transporting with casters

1. This product is heavy and should be moved by at least two people to avoid falling.
2. Do not grip the piping port on the back side or the handles of the panel.
3. Do not pass over bumps, etc., with the casters.

### Caution

If this product is to be transported after delivery, please use the original packaging the product was delivered in. If other packaging is to be used, carefully package the product so as to prevent the product from incurring any damage during transport.

## Installation

### Warning

1. Do not place heavy objects on top of this product, or step on it.  
The external panel can be deformed and danger can result.

### Caution

1. Install on a rigid floor which can withstand this product's weight.
2. Refer to the Operation Manual for this product, and secure an installation space that is necessary for the maintenance and ventilation.

#### <Air-cooled refrigeration>

1. The air-cooled type product exhausts heat using the fan that is mounted to the product. If the product is operated with insufficient ventilation, ambient temperature may exceed 45°C, and this will affect the performance and life of the product. To prevent this ensure that suitable ventilation is available (see below).
2. For installation indoors, ventilation ports and a ventilation fan should be equipped as needed.

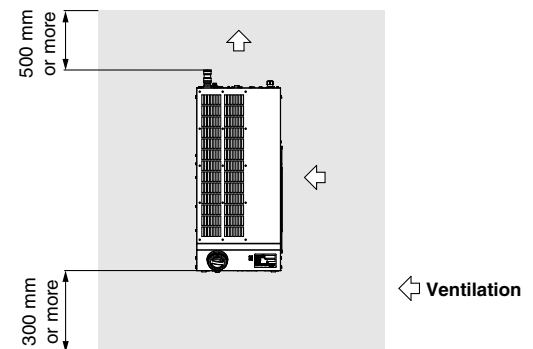
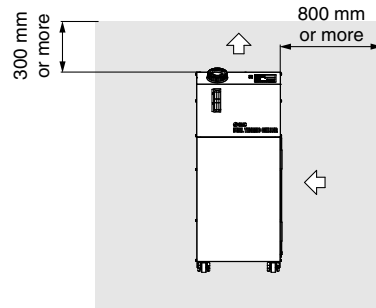

3. If it is impossible to exhaust heat from the installation area indoors, or when the installation area is conditioned, provide a duct for heat exhaustion to the air outlet port of this product for ventilation. Do not mount the inlet of the duct (flange) directly to the air vent of the product, and keep a space larger than the diameter of the duct. Additionally, consider the resistance of the duct when making the air vent port for the duct.

#### <Heat radiation amount / Required ventilation rate>

Model	Heat radiation amount [kW]	Required ventilation rate [m <sup>3</sup> /min]	
		Differential temp. of 3°C between inside and outside of installation area	Differential temp. of 6°C between inside and outside of installation area
HRLE050-A-20	Approx.10	140	70
HRLE090-A-20/40	Approx.18	305	155



# HRLE Series Specific Product Precautions 3

Be sure to read this before handling the products. Refer to the back cover for safety instructions. For temperature control equipment precautions, refer to the "Handling Precautions for SMC Products" and the "Operation Manual" on the SMC website: <https://www.smcworld.com>

## Piping

### ⚠ Caution

1. The circulating fluid and facility water piping should be prepared by the customer with consideration of the operating pressure, temperature, and circulating fluid/facility compatibility.

If the operating performance is not sufficient, the pipings may burst during operation. Also, the use of corrosive materials such as aluminum or iron for fluid contact parts, such as piping, may not only lead to clogging or leakage in the circulating fluid and facility water circuits but also refrigerant leakage and other unexpected problems. Provide protection against corrosion when you use the product.

2. Select the piping port size which can exceed the rated flow. For the rated flow, refer to the pump capacity table.
3. When tightening at the drain port of this product, use a pipe wrench to clamp the connection ports.
4. For the circulating fluid piping connection, install a drain pan and wastewater collection pit just in case the circulating fluid may leak.
5. This product series are constant-temperature fluid circulating machines with built-in tanks. Do not install equipment on your system side such as pumps that forcibly return the circulating fluid to the unit. Also, if you attach an external tank that is open to the air, it may become impossible to circulate the circulating fluid. Proceed with caution.
6. The facility water flow rate is adjusted automatically according to the operating conditions. In addition, the facility water return temperature is 60°C at max.

## Circulating Fluid

### ⚠ Caution

1. Avoid oil or other foreign matter entering the circulating fluid.
2. When water is used as a circulating fluid, use tap water that conforms to the appropriate water quality standards. Use tap water that conforms to the standards shown below (including water used for dilution of ethylene glycol aqueous solution).

#### Tap Water (as a Circulating Fluid) Quality Standards

The Japan Refrigeration and Air Conditioning Industry Association  
JRA GL-02-1994 "Cooling water system - Circulation type - Make-up water"

	Item	Unit	Standard value	Influence	
				Corrosion	Scale generation
Standard item	pH (at 25°C)	—	6.0 to 8.0	○	○
	Electric conductivity (25°C)	[μS/cm]	100*1 to 300*1	○	○
	Chloride ion (Cl <sup>-</sup> )	[mg/L]	50 or less	○	
	Sulfuric acid ion (SO <sub>4</sub> <sup>2-</sup> )	[mg/L]	50 or less	○	
	Acid consumption amount (at pH4.8)	[mg/L]	50 or less		○
	Total hardness	[mg/L]	70 or less		○
	Calcium hardness (CaCO <sub>3</sub> )	[mg/L]	50 or less		○
	Ionic state silica (SiO <sub>2</sub> )	[mg/L]	30 or less		○
Reference item	Iron (Fe)	[mg/L]	0.3 or less	○	○
	Copper (Cu)	[mg/L]	0.1 or less	○	
	Sulfide ion (S <sub>2</sub> <sup>-</sup> )	[mg/L]	Should not be detected	○	
	Ammonium ion (NH <sub>4</sub> <sup>+</sup> )	[mg/L]	0.1 or less	○	
	Residual chlorine (Cl)	[mg/L]	0.3 or less	○	
	Free carbon (CO <sub>2</sub> )	[mg/L]	4.0 or less	○	

\*1 In the case of [MΩ·cm], it will be 0.003 to 0.01.

- : Factors that have an effect on corrosion or scale generation
- Even if the water quality standards are met, complete prevention of corrosion is not guaranteed.

3. When deionized (pure) water is used, the electric conductivity should be 0.5 μS/cm or higher (Electric resistivity: 2 MΩ·cm or lower).

## Electrical Wiring

### ⚠ Warning

Grounding should never be connected to a water line, gas line or lightning rod.

### ⚠ Caution

1. Power supply and communication cables should be prepared by the customer.

2. Provide a stable power supply which is not affected by surge or distortion.

If the voltage increase ratio (dV/dt) at the zero cross should exceed 40 V/200 μsec., it may result in malfunction.

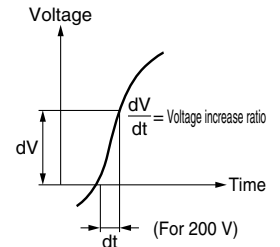

3. This product is installed with a breaker with the following operating characteristics.

For the customer system side (on the upstream side), use a breaker whose operating time is equal to or longer than the breaker of this product. If a breaker with shorter operating time is connected, the customer equipment could be cut off due to the inrush current of the motor of this product.

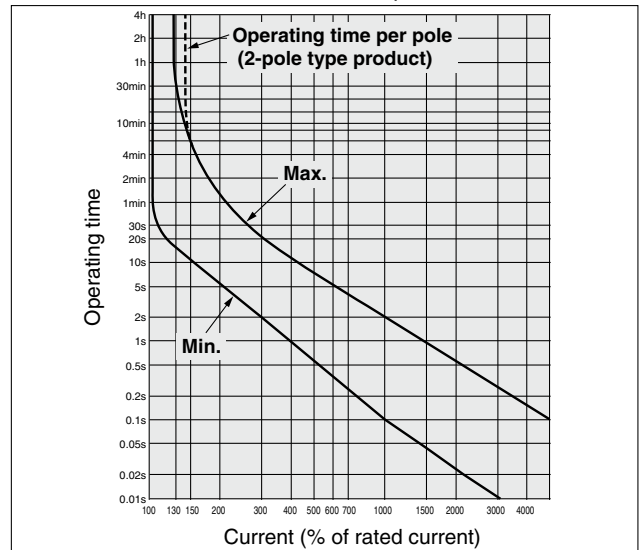

HRLE050

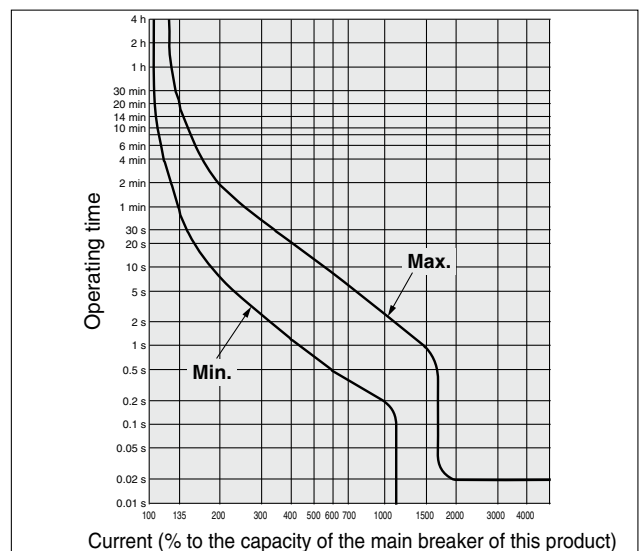

HRLE090



# HRLE Series Specific Product Precautions 4

Be sure to read this before handling the products. Refer to the back cover for safety instructions. For temperature control equipment precautions, refer to the “Handling Precautions for SMC Products” and the “Operation Manual” on the SMC website: <https://www.smcworld.com>

## Facility Water Supply

### Warning

<Water-cooled refrigeration>

1. The water-cooled refrigeration type thermo-chiller radiates heat to the facility water. Prepare the facility water system that satisfies the heat radiation and the facility water specifications below.

#### ■ Required Facility Water System

<Heat radiation amount / Facility water specifications>

Model	Heat radiation [kW]	Facility water specifications
HRLE050-W-□-□	Approx. 10	Refer to “Facility water system” in the specifications on page 9-1.
HRLE090-W-□-□	Approx. 20	Refer to “Facility water system” in the specifications on pages 10 and 12.





# HRLE Series Specific Product Precautions 4

Be sure to read this before handling the products. Refer to the back cover for safety instructions. For temperature control equipment precautions, refer to the “Handling Precautions for SMC Products” and the “Operation Manual” on the SMC website: <https://www.smcworld.com>

## Facility Water Supply

### Warning

#### 2. When using tap water as facility water, use tap water that conforms to the appropriate water quality standards.

Use tap water that conforms to the standards shown below. If the water quality standards are not met, clogging or leakage in the facility water piping, or other problems such as refrigerant leakage, etc., may result.

#### Tap Water (as Facility Water) Quality Standards

The Japan Refrigeration and Air Conditioning Industry Association  
JRA GL-02-1994 “Cooling water system – Circulation type – Make-up water”

	Item	Unit	Standard value	Influence	
				Corrosion	Scale generation
Standard item	pH (at 25°C)	—	6.5 to 8.2	○	○
	Electric conductivity (25°C)	[μS/cm]	100*1 to 800*1	○	○
	Chloride ion (Cl <sup>-</sup> )	[mg/L]	200 or less	○	
	Sulfuric acid ion (SO <sub>4</sub> <sup>2-</sup> )	[mg/L]	200 or less	○	
	Acid consumption amount (at pH4.8)	[mg/L]	100 or less		○
	Total hardness	[mg/L]	200 or less		○
	Calcium hardness (CaCO <sub>3</sub> )	[mg/L]	150 or less		○
	Ionic state silica (SiO <sub>2</sub> )	[mg/L]	50 or less		○
Reference item	Iron (Fe)	[mg/L]	1.0 or less	○	○
	Copper (Cu)	[mg/L]	0.3 or less	○	
	Sulfide ion (S <sub>2</sub> <sup>-</sup> )	[mg/L]	Should not be detected	○	
	Ammonium ion (NH <sub>4</sub> <sup>+</sup> )	[mg/L]	1.0 or less	○	
	Residual chlorine (Cl)	[mg/L]	0.3 or less	○	
	Free carbon (CO <sub>2</sub> )	[mg/L]	4.0 or less	○	

\*1 In the case of [MΩ·cm], it will be 0.001 to 0.01.

- : Factors that have an effect on corrosion or scale generation
- Even if the water quality standards are met, complete prevention of corrosion is not guaranteed.

#### 3. Set the supply pressure between 0.3 to 0.5 MPa. Ensure a pressure difference at the facility water inlet/outlet of 0.3 MPa or more.

If the supply pressure is high, it will cause water leakage. If the supply pressure and pressure difference at the facility water inlet/outlet is low, it will cause an insufficient flow rate of the facility water, and poor temperature control.

## Operation

### Warning

#### 1. Confirmation before operation

- The fluid level of a tank should be within the specified range of H (High) and L (Low). When exceeding the specified level, the circulating fluid will overflow.
- Remove the air.  
Conduct a trial operation, looking at the fluid level. Since the fluid level will go down when the air is removed from the customer's piping system, supply water once again when the fluid level is reduced. When there is no reduction in the fluid level, the job of removing the air is completed.

#### 2. Confirmation during operation

- Check the circulating fluid temperature.  
The operating temperature ranges of the circulating fluid are as follows: 15 to 25°C for CH1, and CH1 + 0 to 15°C for CH2. When the amount of heat generated from the customer equipment is greater than the product's capability, the circulating fluid temperature may exceed these ranges. Use caution regarding this matter.

#### 3. Emergency stop method

- When an abnormality is confirmed, stop the machine immediately. After stopping operation, disconnect the power supply from the customer equipment.

## Operation Restart Time / Operation and Suspension Frequency

### Caution

- Wait five minutes or more before restarting operation after it has been stopped. If the operation is restarted within five minutes, the protection circuit may activate and the operation may not start properly.
- Operation and suspension frequency should not exceed 10 times per day. Frequently switching between operation and suspension may result in the malfunction of the refrigeration circuit.

## Protection Circuit

### Caution

If operating in the conditions below, the protection circuit will activate and an operation may not be performed or will stop.

- Power supply voltage is not within the rated voltage range of ±10%.
- In case the water level inside the tank is reduced abnormally
- Circulating fluid temperature is too high.
- Compared to the cooling capacity, the heat generation amount of the customer equipment is too high.
- Ambient temperature is too high. (Check the ambient temperature in the specifications.)
- Ventilation grille is clogged with dust or dirt.

## Maintenance

### Caution

#### <Periodical inspection every one month>

##### Clean the ventilation grille.

If the dustproof filter of air-cooled type product becomes clogged with dust or debris, a decline in cooling performance can result. In order to avoid deforming or damaging the dustproof filter, clean it with a long-haired brush or air gun.

#### <Periodical inspection every three months>

##### Inspect the circulating fluid.

- When using tap water or deionized (pure) water
  - Replacement of circulating fluid  
Failure to replace the circulating fluid can lead to the development of bacteria or algae. Replace it regularly depending on your usage conditions.
  - Tank cleaning (same as the HRS series)  
Consider whether dirt, slime or foreign matter may be present in the circulating fluid inside the tank, and carry out regular cleanings of the tank.
- When using ethylene glycol aqueous solution  
Use a concentration meter to confirm that the concentration does not exceed 15%.  
Dilute or add as needed to adjust the concentration.

#### <Periodical inspection during the winter season>

##### 1. Make water-removal arrangements beforehand.

If there is a risk of the circulating fluid and facility water freezing when the product is stopped, release the circulating fluid and facility water in advance.

##### 2. Consult a professional.

This product has an “anti-freezing function.” Read the Operation Manual carefully, and if any additional anti-freezing function (e.g. tape heater) is needed, ask for it from the vendor.





# HRLE Series

## Specific Product Precautions 5

Be sure to read this before handling the products. Refer to the back cover for safety instructions. For temperature control equipment precautions, refer to the “Handling Precautions for SMC Products” and the “Operation Manual” on the SMC website: <https://www.smcworld.com>



### ■ Refrigerant with GWP reference

Refrigerant	Global Warming Potential (GWP)	
	Regulation (EU) No 517/2014 (Based on the IPCC AR4)	Revised Fluorocarbons Recovery and Destruction Law (Japanese law)
R134a	1,430	1,430
R404A	3,922	3,920
R407C	1,774	1,770
R410A	2,088	2,090

- \* This product is hermetically sealed and contains fluorinated greenhouse gases (HFC). When this product is sold on the market in the EU after January 1, 2017, it needs to be compliant with the quota system of the F-Gas Regulation in the EU.
- \* See specification table for refrigerant used in the product.

## Safety Instructions

These safety instructions are intended to prevent hazardous situations and/or equipment damage. These instructions indicate the level of potential hazard with the labels of “**Caution**,” “**Warning**” or “**Danger**.” They are all important notes for safety and must be followed in addition to International Standards (ISO/IEC), and other safety regulations.

-  **Caution:** **Caution** indicates a hazard with a low level of risk which, if not avoided, could result in minor or moderate injury.
-  **Warning:** **Warning** indicates a hazard with a medium level of risk which, if not avoided, could result in death or serious injury.
-  **Danger:** **Danger** indicates a hazard with a high level of risk which, if not avoided, will result in death or serious injury.

## Compliance Requirements

1. The use of SMC products with production equipment for the manufacture of weapons of mass destruction (WMD) or any other weapon is strictly prohibited.
2. The exports of SMC products or technology from one country to another are governed by the relevant security laws and regulations of the countries involved in the transaction. Prior to the shipment of a SMC product to another country, assure that all local rules governing that export are known and followed.

## Caution

**SMC products are not intended for use as instruments for legal metrology.** Measurement instruments that SMC manufactures or sells have not been qualified by type approval tests relevant to the metrology (measurement) laws of each country. Therefore, SMC products cannot be used for business or certification ordained by the metrology (measurement) laws of each country.

## Warning

### 1. The compatibility of the product is the responsibility of the person who designs the equipment or decides its specifications.

Since the product specified here is used under various operating conditions, its compatibility with specific equipment must be decided by the person who designs the equipment or decides its specifications based on necessary analysis and test results. The expected performance and safety assurance of the equipment will be the responsibility of the person who has determined its compatibility with the product. This person should also continuously review all specifications of the product referring to its latest catalog information, with a view to giving due consideration to any possibility of equipment failure when configuring the equipment.

### 2. Only personnel with appropriate training should operate machinery and equipment.

The product specified here may become unsafe if handled incorrectly. The installation, operation, and maintenance of the product must be performed by an operator who is appropriately trained and experienced and who has a thorough understanding of the precautions in the operation manual and maintenance materials.

### 3. Contact SMC beforehand and take special consideration of safety measures if the product is to be used in any of the following conditions.

1. Use of the product under conditions and environments outside of the specifications described in the catalog or operation manual.
2. Installation on equipment in conjunction with atomic energy, railways, air navigation, space, shipping, vehicles, military, medical treatment, combustion and recreation, or equipment in contact with food and beverages, emergency stop circuits, clutch and brake circuits in press applications, safety equipment or other applications unsuitable for the standard specifications described in the product catalog.
3. An application which could have negative effects on people, property, or animals requiring special safety analysis.

## Limited warranty and Disclaimer/ Compliance Requirements

The product used is subject to the following “Limited warranty and Disclaimer” and “Compliance Requirements”.

Read and accept them before using the product.

## Limited warranty and Disclaimer

### 1. Period

The warranty period of the product is 1 year in service or 1.5 years after the product is delivered, whichever is first.

### 2. Scope

For any failure reported within the warranty period which is clearly our responsibility, replacement parts will be provided. In that case, removed parts shall become the property of SMC. This guarantee applies only to our product independently, and not to any other damage incurred due to the failure of the product.

### 3. Content

The following situations are out of scope of this warranty.

1. The product was incorrectly installed or connected with other equipment.
2. The product was modified or altered in construction.
3. The failure was a secondary failure of the product caused by the failure of equipment connected to the product.
4. The failure was caused by a natural disaster such as an earthquake, typhoon, or flood, or by an accident or fire.
5. The failure was caused by operation different from that shown in the Operation Manual or outside of the specifications.
6. The checks and maintenance specified (daily checks and regular checks) were not performed.
7. The failure was caused by the use of circulating fluid or facility water other than those specified.
8. The failure occurred naturally over time (such as discoloration of a painted or plated face).
9. The failure does not affect the functioning of the product (such as new sounds, noises and vibrations).
10. The failure was due to the “Installation Environment” specified in the Operation Manual.

### 4. Disclaimer

1. Expenses for daily and regular checks
2. Expenses for repairs performed by other companies
3. Expenses for transfer, installation and removal of the product
4. Expenses for replacement of parts other than those in this product, or for the supply of liquids
5. Inconvenience and loss due to product failure (such as telephone bills, compensation for workplace closure, and commercial losses)

For warranted repair, please contact the supplier you purchased this product from.

## Caution

### 1. The product is provided for use in manufacturing industries.

The product herein described is basically provided for peaceful use in manufacturing industries.

If considering using the product in other industries, consult SMC beforehand and exchange specifications or a contract if necessary. If anything is unclear, contact your nearest sales branch.

## Safety Instructions

Be sure to read the “Handling Precautions for SMC Products” (M-E03-3) and “Operation Manual” before use.

# SMC Corporation

Akihabara UDX 15F,  
4-14-1, Sotokanda, Chiyoda-ku, Tokyo 101-0021, JAPAN  
Phone: 03-5207-8249 Fax: 03-5298-5362  
<https://www.smcworld.com>  
© 2022 SMC Corporation All Rights Reserved

Specifications are subject to change without prior notice and any obligation on the part of the manufacturer.

D-G