

# Circulating Fluid Temperature Controller Thermo-chiller

## HRS090 Series

### Standard Type

# Lightweight and Compact

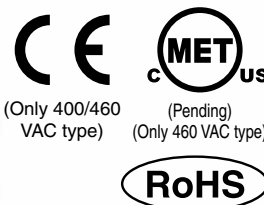

Cooling capacity **9 kW**

Temperature stability

$\pm 0.5^{\circ}\text{C}$ ,  $\pm 0.1^{\circ}\text{C}$  (460 VAC type) (When a load is stable)

Set temperature range **5°C to 35°C**

Max. ambient temperature **45°C**

Indoor use

# Weight 136 kg



Compatible with power supplies in Europe, Asia, Oceania, and North, Central, and South America

- 3-phase 200 V
- 3-phase 400 V
- 3-phase 460 V

Water-cooled refrigeration

Air-cooled refrigeration

### With heating function

As the heating method uses discharged heat, a heater is unnecessary.

#### Convenient functions Page 111

Timer operation function/Unit conversion function/Power failure auto-restart function/Anti-freezing operation function

#### Self-diagnosis function and check display Page 112

41 types of alarm codes

Environmentally friendly **R410A** as refrigerant

#### Easy maintenance Page 110

Toolless maintenance of filter

#### Communication function Page 112

Equipped with serial communication (RS232C/RS485) and contact I/Os (2 inputs and 3 outputs) as standard

- HRS
- HRS-R
- HRS090
- HRS 100/150
- HRS200
- HRS090
- HRSH
- HRSE
- HRR
- HRL
- HRZ
- HRZD
- HRW
- HECR
- HEC
- HEB
- HED
- Technical Data

# Compact and lightweight 136 kg

A precision temperature control method which utilizes expansion valves and temperature sensors allowed for the realization of a product with a high temperature stability of  $\pm 0.5^{\circ}\text{C}$  and a small-size tank.

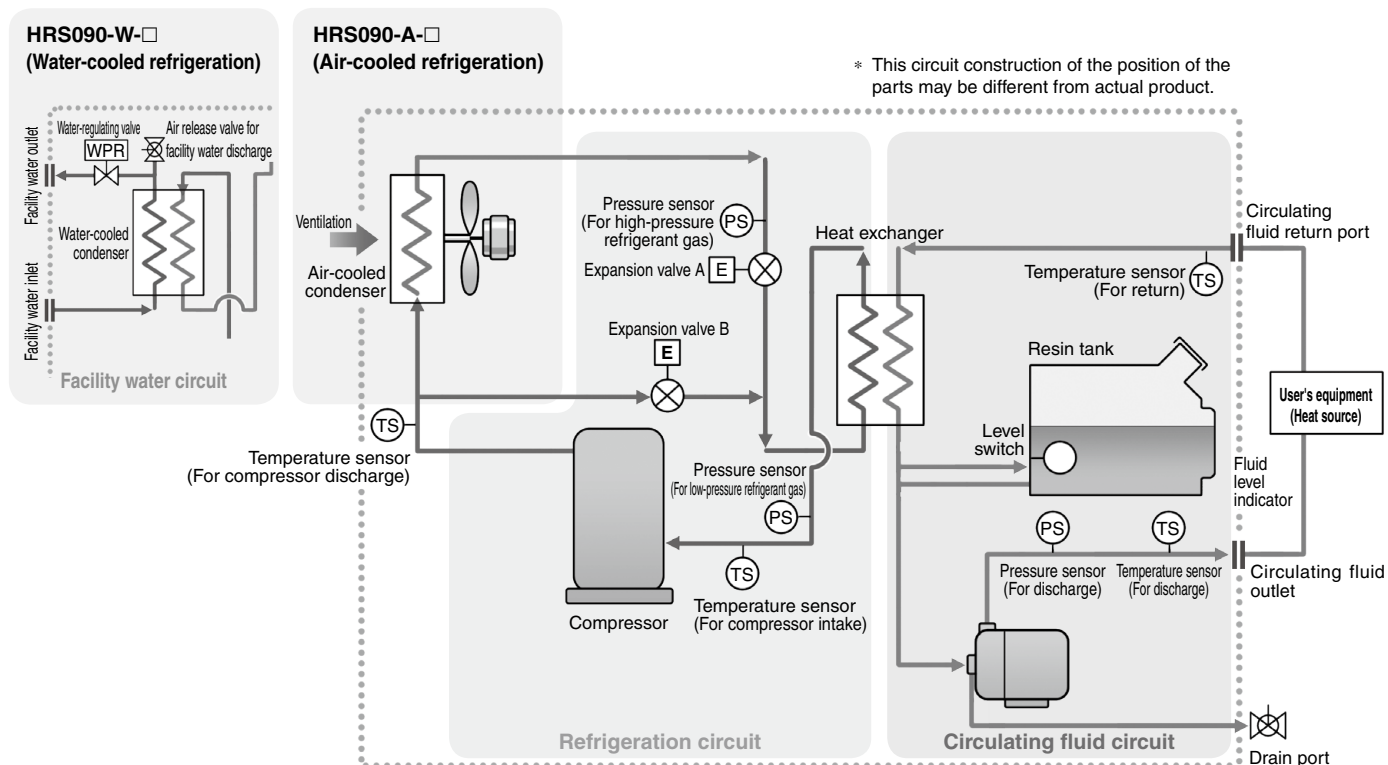

## Refrigeration circuit

- The compressor compresses the refrigerant gas and discharges high-temperature, high-pressure refrigerant gas.
- In the case of air-cooled refrigeration, the high-temperature, high-pressure refrigerant gas is cooled down by fan ventilation in the air-cooled condenser, where it is then liquefied. In the case of water-cooled refrigeration, the refrigerant gas is cooled by the facility water in the facility water circuit in the water-cooled condenser, where it is then liquefied.
- The liquefied high-pressure refrigerant gas expands and its temperature lowers when it passes through expansion valve A, where it vaporizes after receiving heat from the circulating fluid in the heat exchanger.
- The vaporized refrigerant gas is sucked into the compressor and compressed again.
- When heating the circulating fluid, the high-pressure, high-temperature refrigerant gas is bypassed into the evaporator by expansion valve B to heat the circulating fluid.

**Point** The combination of the precise control of **expansion valve A** for cooling and **expansion valve B** for heating allows for high temperature stability.

## Circulating fluid circuit

- After the circulating fluid discharged from the pump is heated or cooled by the user's equipment, it returns to the thermo-chiller.
- The circulating fluid is controlled to remain at a set temperature by the refrigeration circuit. It will then be discharged to the user's equipment side again by the thermo-chiller.

**Point** Since the refrigeration circuit is controlled by the signals from **2 temperature sensors (for return and discharge)**, precise temperature control of the circulating fluid can be achieved. Therefore, there is no need for a tank with a large capacity to absorb the circulating fluid temperature difference, as high temperature stability can be achieved even with a **small-size tank**. This also contributes to space saving.

## Facility water circuit

### For water-cooled refrigeration HRS-□-W-□

- The water-regulating valve opens and closes to keep the refrigerant gas pressure consistent. The facility water flow rate is controlled by the water-regulating valve.

## Reduced-height double condenser structure

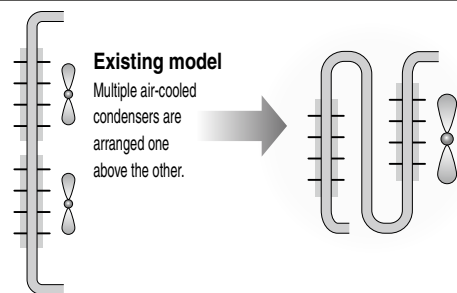

A maximum reduction in the height of the product has been achieved while expanding the cooling capacity by providing overlapped air-cooled condensers.

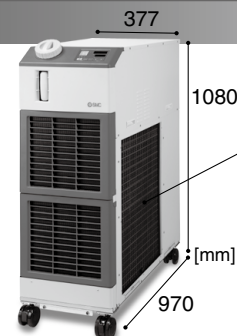

**Aluminum air-cooled condenser**  
High heat transfer efficiency, Lightweight

**Compact tank 18 L**  
Temperature followability control reduced the tank capacity required as a buffer.



### Power supply (24 VDC) available

Power can be supplied from the terminal block on the rear side to external switches, etc.

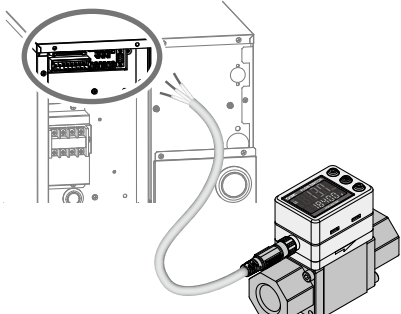

**Flow switch**  
Refer to the Web Catalog for details.

### Electric conductivity control set

(With DI filter + Solenoid valve kit for control) (Optional accessory on page 126)

The electric conductivity of the circulating fluid can be set with the controller monitor arbitrarily.

Set control range:  
5.0 to 45.0  $\mu\text{S/cm}$

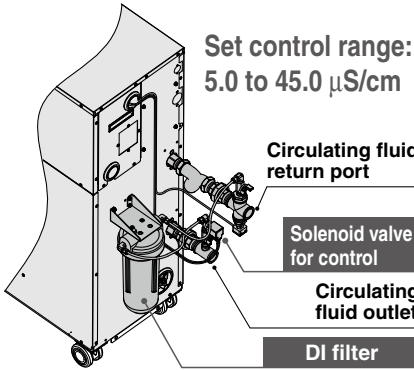

### Globally compatible power supplies

(Europe, Asia, Oceania, North, Central and South America) 

**Transformer unnecessary** (Only 400/460 VAC type)

**Power supply** Applicable to 200 to 230 VAC, 380 to 415 VAC, or 460 to 480 VAC

Transformers are unnecessary even when used overseas.

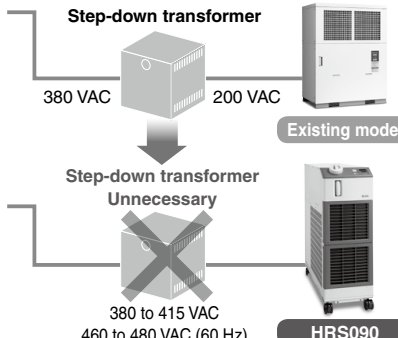

### Particle filter set p. 126

Removes foreign matter in the circulating fluid  
 Effective in preventing foreign matter from entering the user's equipment and chiller

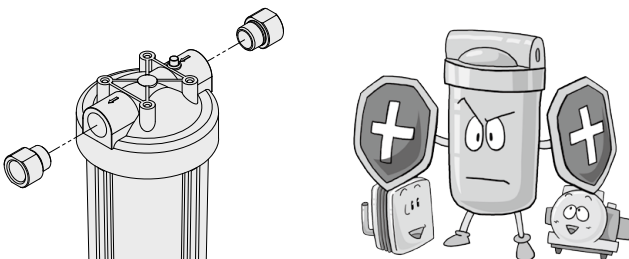

Protects the pump and condenser from foreign matter!!

- Prevents pump malfunction
- Prevents the water-cooled condenser performance from falling.

### Wired remote controller

(Optional accessory on page 128)

Operable from a distance

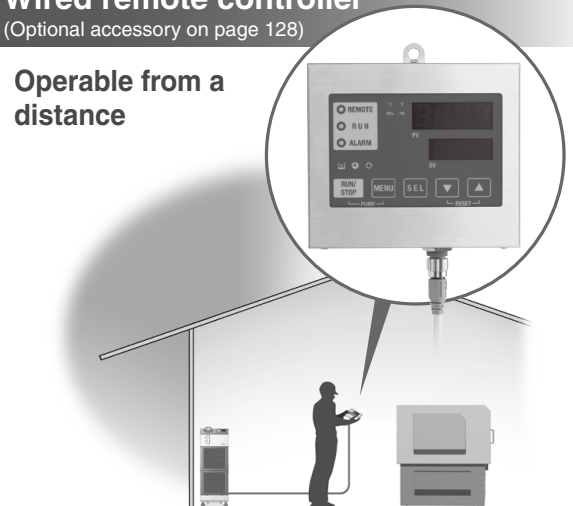

### Convenient functions (Refer to the Operation Manual for details.)

#### ■ Timer operation function

Timer for ON and OFF can be set in units of 0.5 h up to 99.5 h.

Ex.) Can be set to stop on Saturday and Sunday and restart on Monday morning

**Ex. SE.02 "ON timer"**

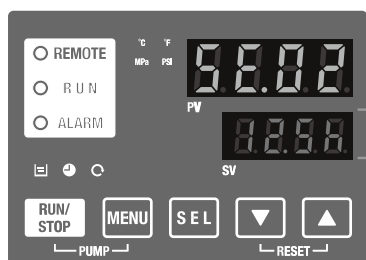

**Timer** The time remaining can be checked.



#### ■ Unit conversion function

Temperature and pressure units can be changed.

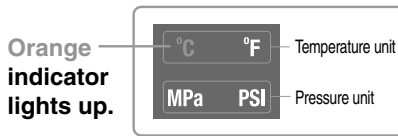
**Orange indicator lights up.**

#### ■ Power failure auto-restart function

Automatic restart after stoppage due to power failure, etc., is possible without pressing the **RUN/STOP** key, and remote operation is also possible.

#### ■ Anti-freezing operation function

If the circulating fluid approaches its freezing point, for example, on a cold winter night, the pump operates automatically, and the heat generated by the pump warms the circulating fluid, preventing freezing.

#### ■ Key-lock function

Can be set in advance to protect the set values from being changed by pressing keys by mistake.

#### ■ Function to output a signal for completion of preparation

Notifies by communication when the temperature reaches the pre-set temperature range

#### ■ Independent operation of the pump

The pump can be operated independently while the chiller is powered off. This allows you to check for leakages in piping and to remove the air.



## Applications

### Laser beam machine/ Laser welding machine

Cooling of the laser oscillation part and power source



### Printing machine

Temperature control of the roller

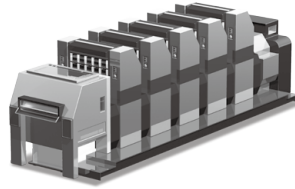

### Cleaning machine

Temperature control of cleaning solution

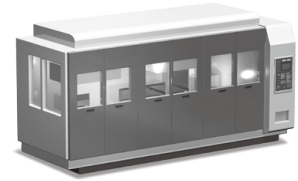

### Arc welding machine

Cooling of the torch

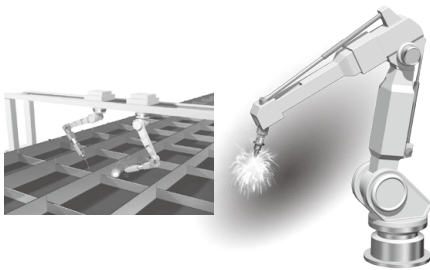

### Resistance welding machine (spot welding)

Cooling of the welding head electrodes, transformers and transistors (thyristors)

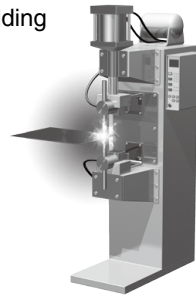

### High-frequency induction heating equipment

Cooling of the heating coils, high-frequency power source and around inverters



### X-ray (digital) instrument

Temperature control of X-ray tube and X-ray light sensing part

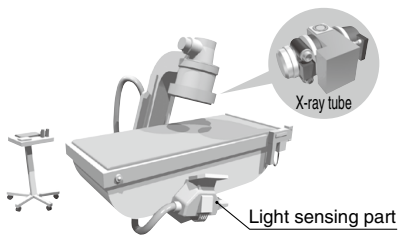

### Packaging line (sealing of film and paper package)

Cooling of workpieces for bonding

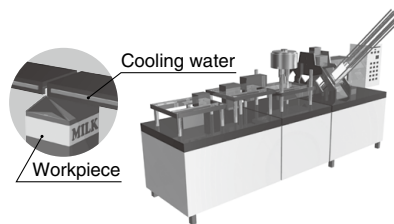

### MRI

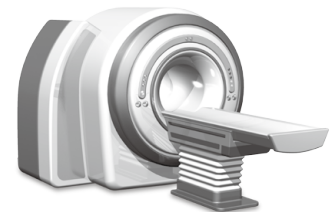

### Injection molding

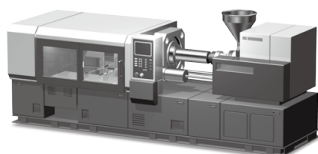

### Atomizing device (food and cosmetics)

Temperature control of sample and device



### Crushing machine

Cooling of the jacket

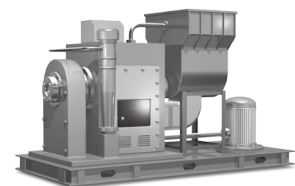



## Global Supply Network

**SMC has a comprehensive network in the global market.**

We now have a presence of more than 560 branch offices and distributors in 83 countries and regions worldwide, such as Asia, Oceania, North/Central/South America, and Europe. With this global network, we are able to provide a global supply of our substantial range of products and high-quality customer service. We also provide full support to local factories, foreign manufacturing companies, and Japanese companies in each country.



HRS

HRS-R

HRS090

HRS  
100/150

HRS200

HRS090

HRS

HRS

HRS

HRS

HRS

HRS

HRS

HRS

HRS







HRS

HRS

HRS

## SMC Thermo-chiller Variations

Lots of variations are available according to the users' requirements.

Series	Temperature stability [°C]	Set temperature range [°C]	Cooling capacity [kW]													Environment	International standards	
			1.2	1.8	2.4	3	5	6	9	10	15	20	25	28				
 <b>HRSE Basic type</b>	±2.0	10 to 30	●	●	●												Indoor use	CE (Only 230 VAC type)
 <b>HRS Standard type</b>	±0.1	5 to 40	●	●	●	●	●	●									Indoor use	CE (Only 60 Hz)
 <b>HRS090 Standard type</b>	±0.5 ±0.1 (460 VAC type)	5 to 35								●							Indoor use	CE (400/460 V as standard) (Only 460 VAC type, Pending)
 <b>HRS100/150 Standard type</b>	±1.0	5 to 35									●	●					Outdoor installation IPX4	CE (400 V as standard)
 <b>HRS090 Inverter type</b>	±0.1	5 to 40								●							Indoor use	CE (400 V as standard, 200 V as an option) (Only 200 V as an option)
 <b>HRS Inverter type</b>	±0.1	5 to 35									●	●	●	●			Outdoor installation IPX4	CE (400 V as standard, 200 V as an option) (Only 200 V as an option)

Technical Data

## Circulating Fluid/Facility Water Line Equipment

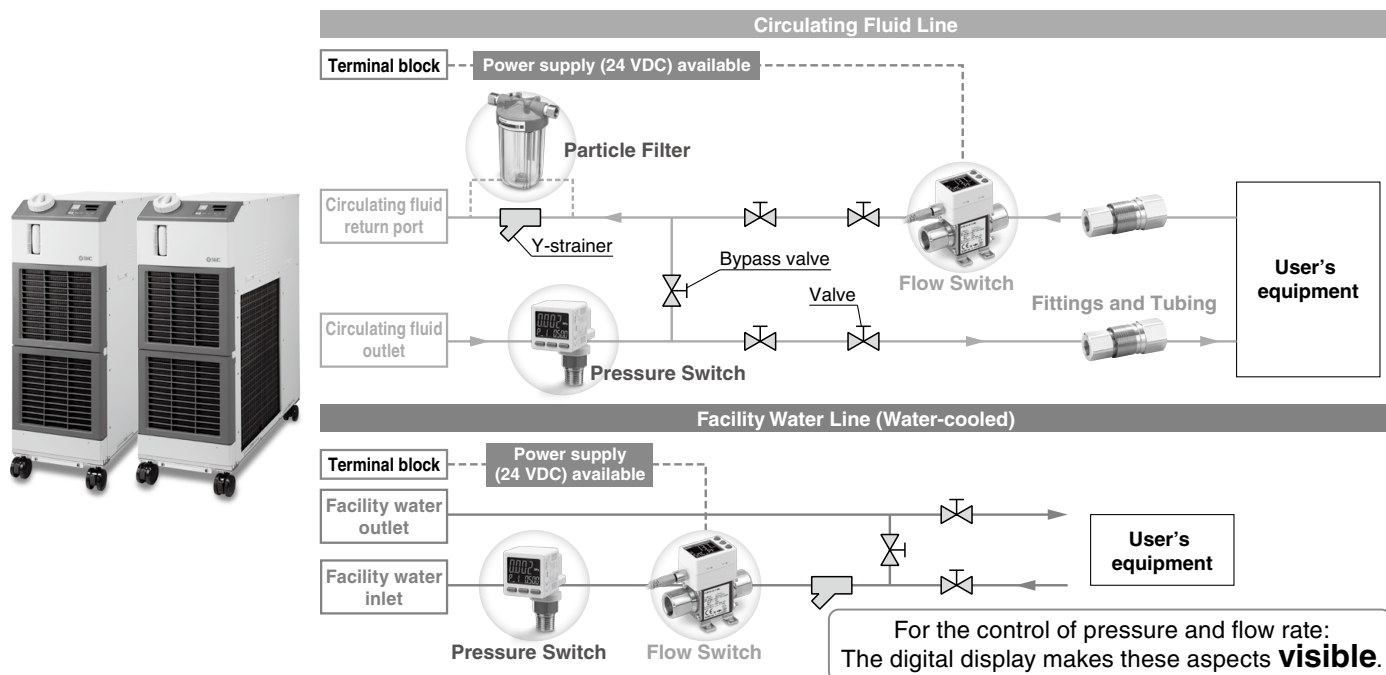

### Flow Switch: Monitors the flow rate and temperature of the circulating fluid and facility water

3-Color Display  
Digital Flow Switch  
for Water

**PF3W**

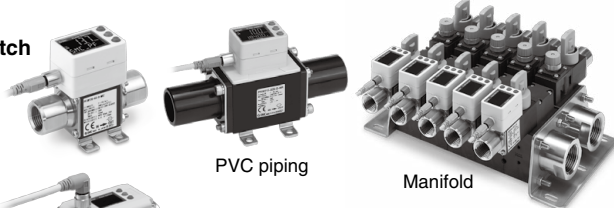

3-Color Display  
Electromagnetic  
Digital Flow Switch

**LFE**

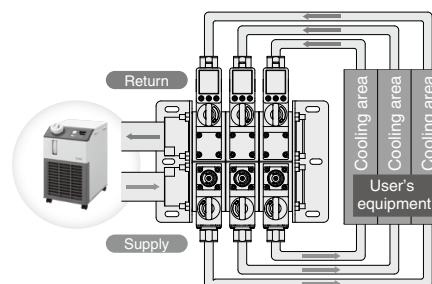

Digital Flow Switch for Deionized Water  
and Chemical Liquids

**PF2D**

4-Channel Flow Monitor **PF2□200**



### Pressure Switch: Monitors the pressure of the circulating fluid and facility water

3-Screen Display High-Precision  
Digital Pressure Switch  
for General Fluids

**ISE20C(H)**



Pressure Sensor for General Fluids **PSE56□**

Pressure Sensor Controller  
**PSE200A, 300A, 300AC**



### Particle Filter



### Fittings

S Coupler  
**KK**



S Coupler/Stainless Steel  
(Stainless Steel 304)

**KKA**



Metal One-touch  
Fittings

**KQB2**



Stainless Steel 316  
One-touch Fittings

**KQG2**



Stainless Steel 316  
Insert Fittings

**KFG2**



Fluoropolymer  
Fittings

**LQ**



Tubing **T□**



Series	Material
T	Nylon
TU	Polyurethane
TH	FEP (Fluoropolymer)
TD	Modified PTFE (Soft fluoropolymer)
TL	Super PFA
TLM	PFA



# CONTENTS

## HRS090 Series **Standard Type**



### Thermo-chiller HRS090 Series

#### How to Order/Specifications

**Air-cooled 200 V/400 V/460 V** ..... Page 117

**Water-cooled 200 V/400 V/460 V** ..... Page 118

Cooling Capacity ..... Page 119

Pump Capacity ..... Page 119

Dimensions ..... Page 120

Recommended External Piping Flow ..... Page 121

Cable Specifications ..... Page 121

Operation Display Panel ..... Page 122

List of Function ..... Page 122

Alarm ..... Page 122

Communication Functions ..... Page 123

#### ● Options

With Earth Leakage Breaker ..... Page 124

With Automatic Fluid Fill Function ..... Page 124

Applicable to Deionized Water Piping ..... Page 124

SI Unit Only ..... Page 124

#### ● Optional Accessories

① Piping Conversion Fitting ..... Page 125

② Bypass Piping Set ..... Page 125

③ Electric Conductivity Control Set ..... Page 126

④ Particle Filter Set ..... Page 126

⑤ Filter for Circulating Fluid Fill Port ..... Page 127

⑥ Drain Pan Set (With Water Leakage Sensor) ... Page 127

⑦ Wired Remote Controller ..... Page 128

#### ● Cooling Capacity Calculation

Required Cooling Capacity Calculation ..... Page 129

Precautions on Cooling Capacity Calculation ... Page 130

Circulating Fluid Typical Physical Property Values ... Page 130

Specific Product Precautions ..... Page 131

HRS

HRS-R

HRS090

HRS  
100/150

HRS200

HRS090

HRS-H

HRS-E

HRR

HRL

HRZ

HRZD

HRW

HECR

HEC

HEB

HED

Technical  
Data

# Thermo-chiller Standard Type

## Air-cooled 200 V/400 V/460 V Type

### HRS090 Series

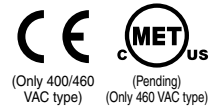

#### How to Order

**HRS 090 - A [ ] - 20 - [ ]**

**Cooling capacity**  
090 9 kW

**Cooling method**  
A Air-cooled refrigeration

**Pipe thread type**

Nil	Rc
F	G (with Rc-G conversion fitting)
N	NPT (with Rc-NPT conversion fitting)

**Option**

Nil	None
B*1	With earth leakage breaker
J	With automatic fluid fill function
M	Applicable to deionized water piping
W	SI unit only

•When multiple options are combined, indicate symbols in alphabetical order.  
\*1 200 V type only.  
400/460 V type is provided with an earth leakage breaker as standard.

**Power supply**

20	3-phase 200 VAC (50 Hz) 3-phase 200 to 230 VAC (60 Hz)
40	3-phase 380 to 415 VAC (50/60 Hz)
46	3-phase 380 to 415 VAC (50/60 Hz) 3-phase 460 to 480 VAC (60 Hz)

#### Specifications

Model		HRS090-A[ ]-20-[ ]	HRS090-A[ ]-40-[ ]	HRS090-A[ ]-46-[ ]
<b>Cooling method</b>		Air-cooled refrigeration		
<b>Refrigerant</b>		R410A (HFC)		
<b>Refrigerant charge</b>	kg	1.15		
<b>Control method</b>		PID control		
<b>Ambient temperature/Humidity/Altitude</b> *1, 2, 10		Temperature: 5 to 45°C, Humidity: 30 to 70%, Altitude: less than 3000 m		
<b>Circulating fluid system</b>	<b>Circulating fluid</b> *3	Tap water, 15% ethylene glycol aqueous solution, Deionized water		
	<b>Set temperature range</b> *2	5 to 35 °C		
	<b>Cooling capacity 50/60 Hz</b> *4	kW 8.0/9.0		
	<b>Heating capacity</b> *5	kW 1.7/2.2		
	<b>Temperature stability</b> *6	±0.5		±0.1
	<b>Pump capacity</b>	<b>Rated flow 50/60 Hz (Outlet)</b> *7	L/min 29/45	
		<b>Maximum flow rate 50/60 Hz</b>	L/min 55/68	
		<b>Maximum pump head</b>	m 50	
	<b>Minimum operating flow rate 50/60 Hz</b> *8	L/min 29/45		
	<b>Tank capacity</b>	L 18		
<b>Circulating fluid outlet, circulating fluid return port</b>	Rc1 (Symbol F: G1, Symbol N: NPT1)			
<b>Tank drain port</b>	Rc1/4 (Symbol F: G1/4, Symbol N: NPT1/4)			
<b>Fluid contact material</b>	Stainless steel, Copper (Heat exchanger brazing), Brass, Bronze, PTFE, FKM, EPDM, PVC, NBR, POM, PE, PP, Carbon, Ceramic			
<b>Electrical system</b>	<b>Power supply</b>	3-phase 200 VAC (50 Hz), 3-phase 200 to 230 VAC (60 Hz) Allowable voltage range ±10% (No continuous voltage fluctuation)	3-phase 380 to 415 VAC (50/60 Hz) Allowable voltage range ±10% (No continuous voltage fluctuation)	3-phase 380 to 415 VAC (50/60 Hz) Allowable voltage range ±10% (No continuous voltage fluctuation) 3-phase 460 to 480 VAC (60 Hz) Allowable voltage range +4%, -10% (Max. voltage less than 500 V and no continuous voltage fluctuation)
	<b>Applicable earth leakage breaker (Standard)</b>	30		20
	<b>Rated current</b>	A 30		20
	<b>Sensitivity of leak current</b>	mA 30		
	<b>Rated operating current 50/60 Hz</b> *6	A 16/18		8.4/9.1
<b>Rated power consumption 50/60 Hz</b> *6	kW (kVA) 4.3/5.4 (5.5/6.0)		4.4/5.6 (5.8/6.3)	
<b>Noise level (Front 1 m/Height 1 m)</b> *6	dB (A) 73		75	
<b>Accessories</b>	Alarm code list stickers 2 pcs. (English 1 pc./Japanese 1 pc.), Operation Manual (for installation/operation) 2 pcs. (English 1 pc./Japanese 1 pc.), Y-strainer (40 meshes) 25A, Barrel nipple 25A, Anchor bolt fixing brackets 2 pcs. (including four M10 bolts)*9			
<b>Weight (dry state)</b>	kg		Approx. 136	

\*1 No condensation should be present.  
\*2 Use a 15% ethylene glycol aqueous solution if operating in a place where the ambient temperature and/or circulating fluid temperature is 10°C or less.  
\*3 Use fluid in condition below as the circulating fluid.  
Tap water: Standard of The Japan Refrigeration And Air Conditioning Industry Association (JRA GL-02-1994)  
15% ethylene glycol aqueous solution: diluted by tap water in condition above without any additives such as antiseptics.  
Deionized water: Electric conductivity 1 μS/cm or higher (Electric resistivity 1 MΩ·cm or lower)  
\*4 ① Ambient temperature: 32°C, ② Circulating fluid: Tap water, ③ Circulating fluid temperature: 20°C, ④ Circulating fluid flow rate: Rated flow, ⑤ Power supply: 200/400 VAC  
\*5 ① Ambient temperature: 32°C, ② Circulating fluid: Tap water, ③ Circulating fluid flow rate: Rated flow, ④ Power supply: 200/400 VAC  
\*6 ① Ambient temperature: 32°C, ② Circulating fluid: Tap water, ③ Circulating fluid temperature: 20°C, ④ Load: Same as the cooling capacity, ⑤ Circulating fluid flow rate: Rated flow, ⑥ Power supply: 200/400 VAC, ⑦ Piping length: Shortest  
\*7 When circulating fluid outlet port pressure = 0.5 MPa.  
\*8 Fluid flow rate to maintain the cooling capacity and to keep the circulating fluid discharge pressure to 0.5 MPa or less. If the actual flow rate is lower than this, install a bypass piping.  
\*9 The anchor bolt fixing brackets (including four M10 bolts) are used for fixing to wooden skids when packaging the thermo-chiller. No anchor bolt is included.  
\*10 If the product is used at an altitude of 1000 m or higher, refer to "Operating Environment/Storage Environment" (page 131) Item 14 "For altitudes of 1000 m or higher."

# Thermo-chiller Standard Type

## Water-cooled 200 V/400 V/460 V Type

### HRS090 Series

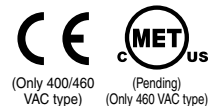

(Only 400/460 VAC type) (Pending) (Only 460 VAC type)



#### How to Order

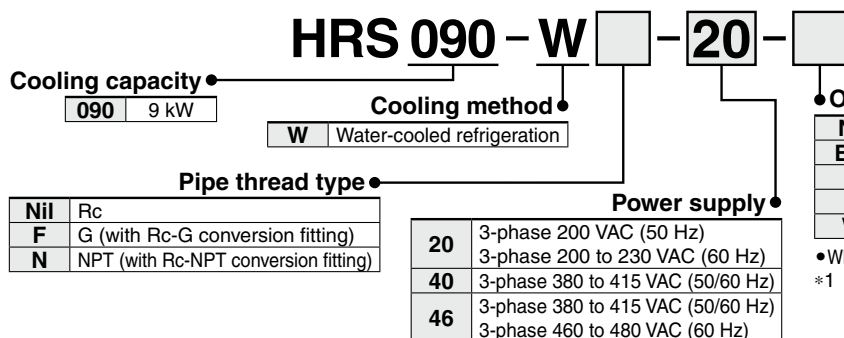

#### Specifications

Model		HRS090-W□-20-□	HRS090-W□-40-□	HRS090-W□-46-□	
<b>Cooling method</b>		Water-cooled refrigeration			
<b>Refrigerant</b>		R410A (HFC)			
<b>Refrigerant charge</b> kg		1.15			
<b>Control method</b>		PID control			
<b>Ambient temperature/Humidity/Altitude</b> *1,2 °C		Temperature: 5 to 45°C, Humidity: 30 to 70%, Altitude: less than 3000 m			
<b>Circulating fluid</b> *3		Tap water, 15% ethylene glycol aqueous solution, Deionized water			
<b>Set temperature range</b> *2 °C		5 to 35			
<b>Cooling capacity 50/60 Hz</b> *4 kW		9.0/10.5			
<b>Heating capacity 50/60 Hz</b> *5 kW		1.7/2.2			
<b>Temperature stability</b> *6 °C		±0.5		±0.1	
<b>Circulating fluid system</b>	<b>Pump capacity</b>	<b>Rated flow 50/60 Hz (Outlet)</b> *7 L/min	29/45		
		<b>Maximum flow rate 50/60 Hz</b> L/min	55/68		
	<b>Maximum pump head</b> m	50			
	<b>Minimum operating flow rate 50/60 Hz</b> *8 L/min	29/45			
	<b>Tank capacity</b> L	18			
<b>Circulating fluid outlet, circulating fluid return port</b>		Rc1 (Symbol F: G1, Symbol N: NPT1)			
<b>Tank drain port</b>		Rc1/4 (Symbol F: G1/4, Symbol N: NPT1/4)			
<b>Fluid contact material</b>		Stainless steel, Copper (Heat exchanger brazing), Brass, Bronze, PTFE, FKM, EPDM, PVC, NBR, POM, PE, PP, Carbon, Ceramic			
<b>Facility water system</b>	<b>Temperature range</b> °C		5 to 40		
	<b>Pressure range</b> MPa		0.3 to 0.5		
	<b>Required flow 50/60 Hz</b> L/min		25/25		
	<b>Facility water pressure differential</b> MPa		0.3 or more		
	<b>Facility water inlet/outlet</b>		Rc1/2 (Symbol F: G1/2, Symbol N: NPT1/2)		
<b>Fluid contact material</b>		Stainless steel, Copper (Heat exchanger brazing), Bronze, Brass, PTFE, NBR, EPDM			
<b>Electrical system</b>	<b>Power supply</b>		3-phase 200 VAC (50 Hz), 3-phase 200 to 230 VAC (60 Hz) Allowable voltage range ±10% (No continuous voltage fluctuation)	3-phase 380 to 415 VAC (50/60 Hz) Allowable voltage range ±10% (No continuous voltage fluctuation)	3-phase 380 to 415 VAC (50/60 Hz) Allowable voltage range ±10% (No continuous voltage fluctuation) 3-phase 460 to 480 VAC (60 Hz) Allowable voltage range +4%, -10% (Max. voltage less than 500 V and no continuous voltage fluctuation)
	<b>Applicable earth leakage breaker</b> *9	<b>Rated current</b> A	30		20
		<b>Sensitivity of leak current</b> mA	30		
	<b>Rated operating current 50/60 Hz</b> *6 A		13/14		6.4/6.7
	<b>Rated power consumption 50/60 Hz</b> *6 kW (kVA)		3.3/4.2 (4.4/4.9)		3.4/4.2 (4.4/4.7)
<b>Noise level (Front 1 m/Height 1 m)</b> *6 dB (A)		65			
<b>Accessories</b>		Alarm code list stickers 2 pcs. (English 1 pc./Japanese 1 pc.), Operation Manual (for installation/operation) 2 pcs. (English 1 pc./Japanese 1 pc.), Y-strainer (40 meshes) 25A, Barrel nipple 25A, Anchor bolt fixing brackets 2 pcs. (including four M10 bolts)*10			
<b>Weight (dry state)</b> kg		Approx. 124			

\*1 No condensation should be present.  
\*2 Use a 15% ethylene glycol aqueous solution if operating in a place where the ambient temperature and/or circulating fluid temperature is 10°C or less. Also, when there is a possibility of the facility water being frozen, make sure to discharge all the facility water from the facility water circuit.  
\*3 Use fluid in condition below as the circulating fluid. Also, when there is a possibility of the facility water being frozen, make sure to discharge all the facility water from the facility water circuit.  
Tap water: Standard of The Japan Refrigeration And Air Conditioning Industry Association (JRA GL-02-1994)  
15% ethylene glycol aqueous solution: diluted by tap water in condition above without any additives such as antiseptics.  
Deionized water: Electric conductivity 1 μS/cm or higher (Electric resistivity 1 MΩ·cm or lower)  
\*4 ① Facility water temperature: 32°C, ② Circulating fluid: Tap water, ③ Circulating fluid temperature: 20°C, ④ Circulating fluid flow rate: Rated flow, ⑤ Power supply: 200/400 VAC  
\*5 ① Facility water temperature: 32°C, ② Circulating fluid: Tap water, ③ Circulating fluid flow rate: Rated flow, ④ Power supply: 200/400 VAC  
\*6 ① Facility water temperature: 32°C, ② Circulating fluid: Tap water, ③ Circulating fluid temperature: 20°C, ④ Load: Same as the cooling capacity, ⑤ Circulating fluid flow rate: Rated flow, ⑥ Power supply: 200/400 VAC, ⑦ Piping length: Shortest  
\*7 When circulating fluid outlet port pressure = 0.5 MPa.  
\*8 Fluid flow rate to maintain the cooling capacity and to keep the circulating fluid discharge pressure to 0.5 MPa or less. If the actual flow rate is lower than this, install a bypass piping.  
\*9 To be prepared by the user. A specified earth leakage breaker is installed for option B [With earth leakage breaker].  
\*10 The anchor bolt fixing brackets (including four M10 bolts) are used for fixing to wooden skids when packaging the thermo-chiller. No anchor bolt is included.

HRS  
HRS-R  
HRS090  
HRS 100/150  
HRS200  
HRS090  
HRS  
HRS  
HRS  
HRR  
HRL  
HRZ  
HRZD  
HRW  
HECR  
HEC  
HEB  
HED  
Technical Data

## Cooling Capacity

### HRS090-A-20/40/46 (50 Hz)

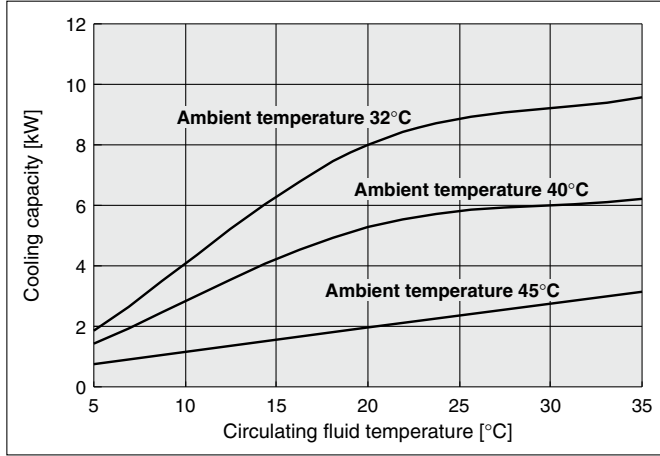

### HRS090-A-20/40/46 (60 Hz)

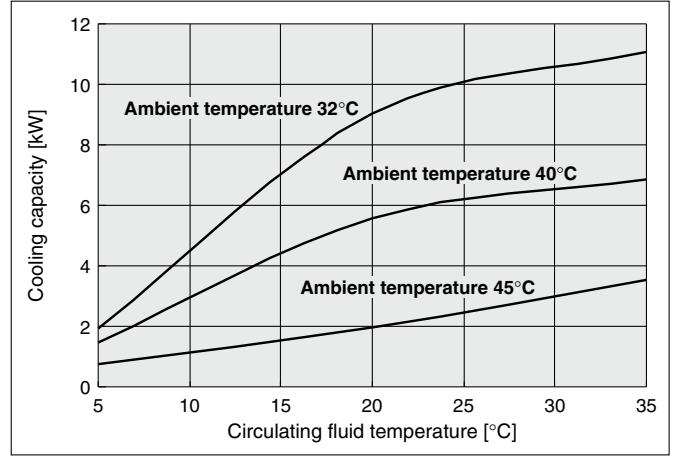

### HRS090-W-20/40/46 (50 Hz)

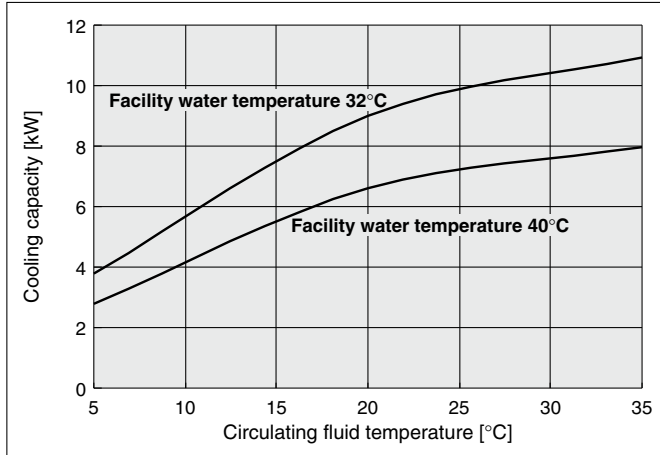

### HRS090-W-20/40/46 (60 Hz)

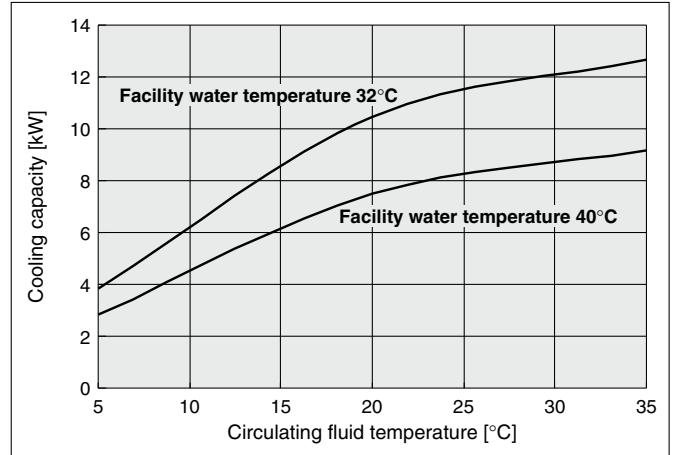

## Pump Capacity

### HRS090-A-20/40/46 HRS090-W-20/40/46

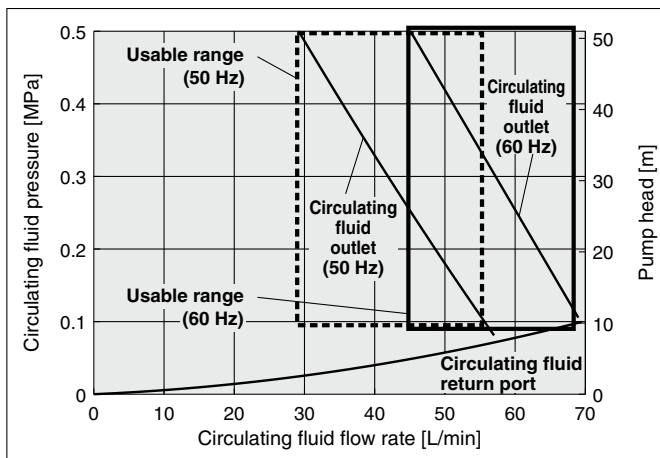

## ⚠ Caution

### Mechanical Seal Pump

The pump used for the thermo-chiller HRS090 series uses a mechanical seal with the fixed ring and rotary ring used for the shaft seal part. If foreign matter enters the gap between the seals, this may cause a trouble such as leakage from the seal part or pump lock. Therefore, it is strongly recommended to install the particle filter in the return piping of the chiller.

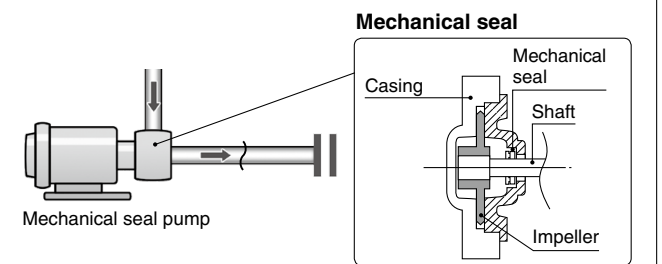

**Dimensions**

**HRS090-□-20/40/46**

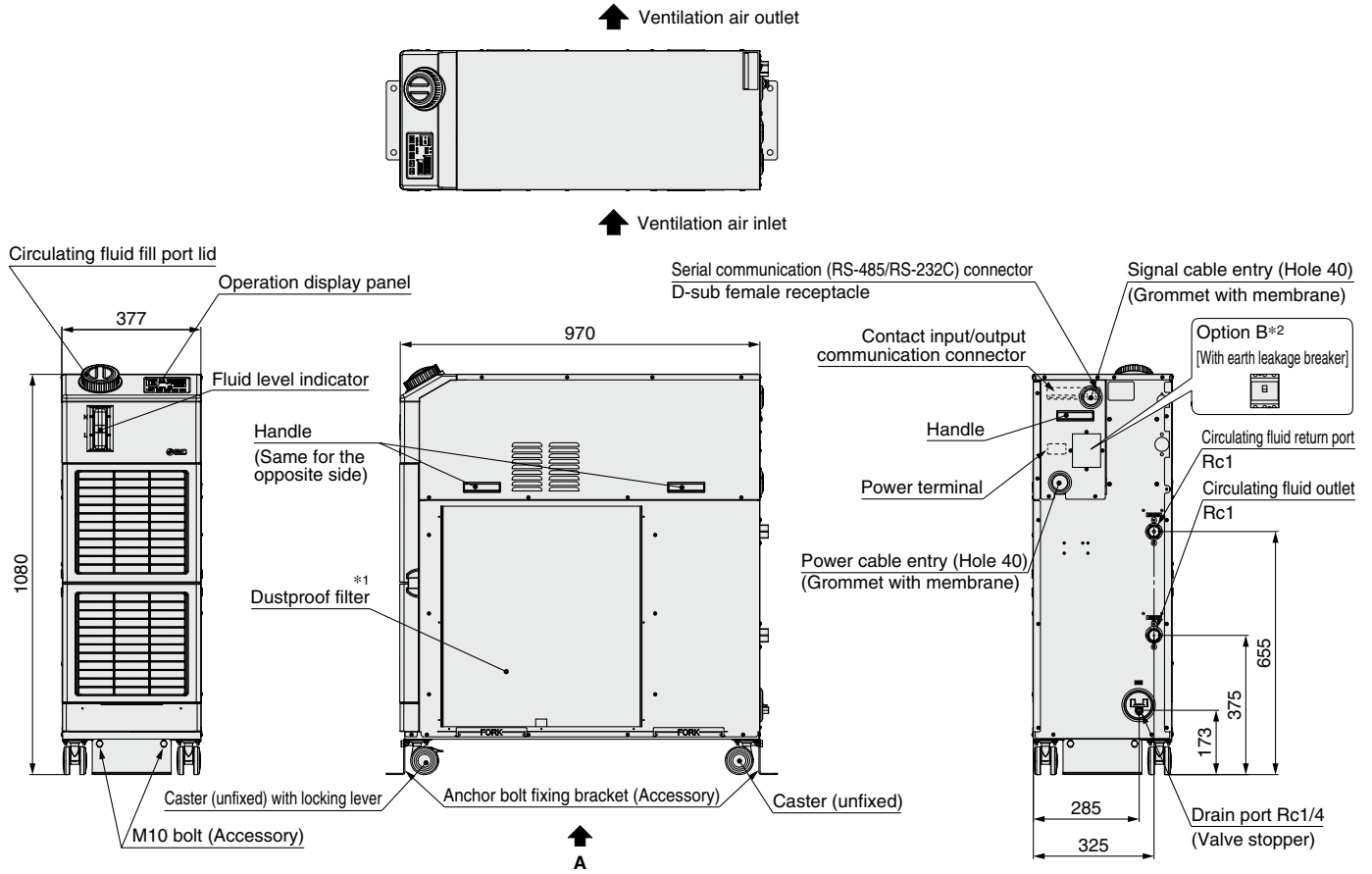

\*1 The water-cooled type is not equipped with a dustproof filter.  
 \*2 400 V type is provided with an earth leakage breaker "B" as standard.

**Anchor bolt fixing position**

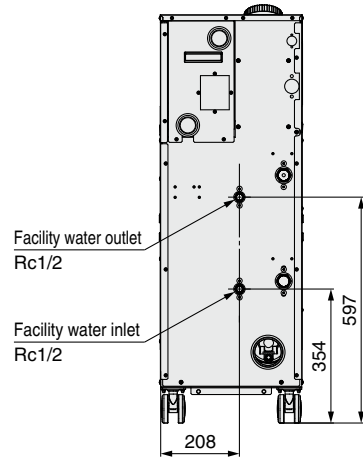
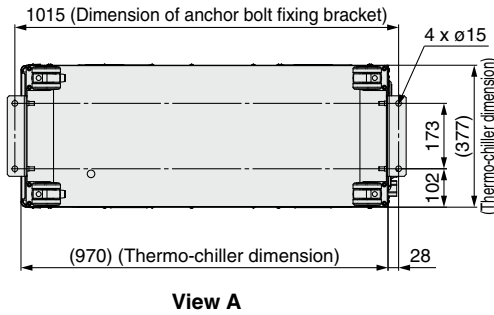

**For water-cooled type**

**Accessory: Y-strainer mounting view**

\* Mount it by yourself on the circulating fluid return port.

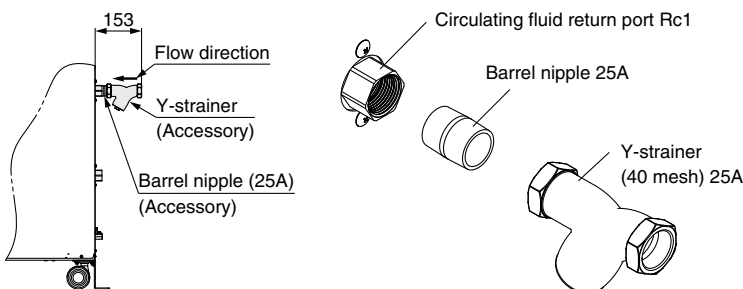

- HRS
- HRS-R
- HRS090
- HRS 100/150
- HRS200
- HRS090
- HRSH
- HRSE
- HRR
- HRL
- HRZ
- HRZD
- HRW
- HECR
- HEC
- HEB
- HED
- Technical Data

## Recommended External Piping Flow

External piping circuit is recommended as shown below.

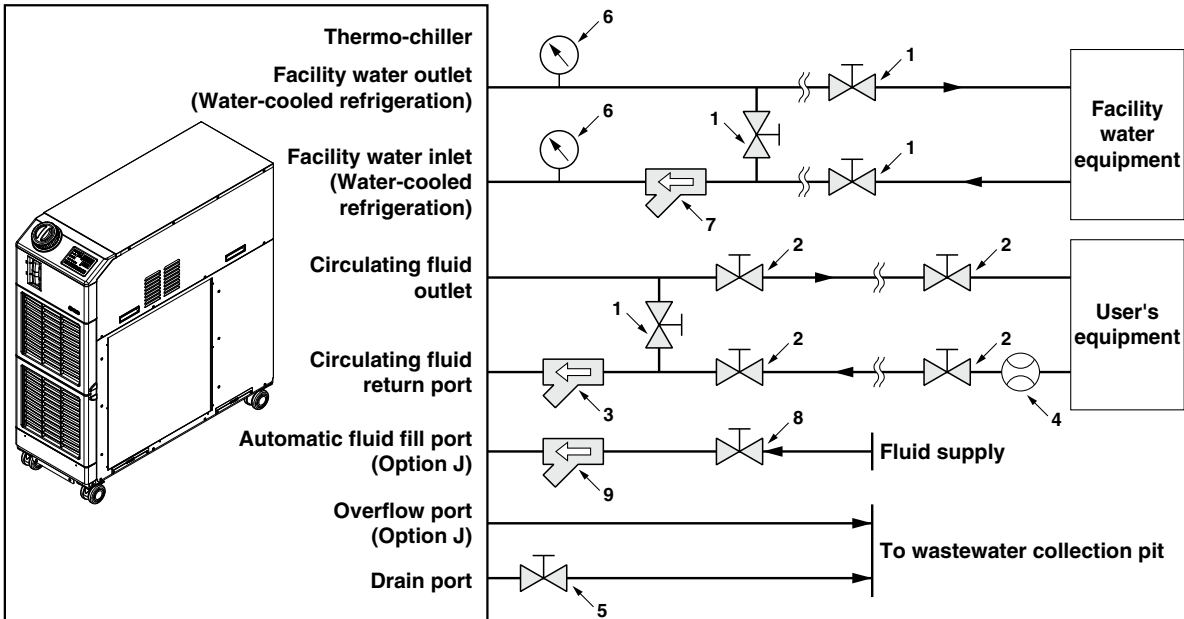

No.	Description	Size	Recommended part no.	Note
1	Valve	Rc1/2	—	—
2	Valve	Rc1	—	—
3	Y-strainer	Rc1 #40	Accessory	Install either the strainer or filter. If foreign matter with a size of 20 μm or more are likely to enter, install the particle filter. For the recommended filter, refer to the optional accessory HRS-PF005 (page 126).
	Filter	Rc1 20 μm	HRS-PF005*1	
4	Flow meter	—	—	Prepare a flow meter with an appropriate flow range.
5	Valve (Part of thermo-chiller)	Rc1/4	—	—
6	Pressure gauge	0 to 1.0 MPa	—	—
7	Y-strainer	Rc1/2 #40	—	Install either the strainer or filter. If foreign matter with a size of 20 μm or more are likely to enter, select the particle filter, and then prepare it.
	Filter	Rc1/2 20 μm	—	
8	Valve	Rc3/8	—	—
9	Y-strainer	Rc3/8 #40	—	Install either the strainer or filter. If foreign matter with a size of 20 μm or more are likely to enter, install the particle filter.
	Filter	Rc3/8 20 μm	FQ1011N-10-T020-B-X61*1	

\*1 The filter shown above cannot be directly connected to the thermo-chiller. Install it in the user's piping system.

## Cable Specifications

### Power Cable Specifications

Applicable model	Rated value for thermo-chiller			Power cable examples	
	Power supply	Applicable breaker rated current	Terminal block screw diameter	Cable size	Crimped terminal on the thermo-chiller side
HRS090-□□-20	3-phase 200 VAC (50 Hz) 3-phase 200 to 230 VAC (60 Hz)	30 A	M5	4 cores x 5.5 mm <sup>2</sup> (4 cores x AWG10) * Including grounding cable	R5.5-5
HRS090-□□-40	3-phase 380 to 415 VAC (50/60 Hz)	20 A			
HRS090-□□-46	3-phase 380 to 415 VAC (50/60 Hz) 3-phase 460 to 480 VAC (60 Hz)				

\* An example of the cable specifications is when two kinds of vinyl insulated wires with a continuous allowable operating temperature of 70°C at 600 V, are used at an ambient temperature of 30°C. Select the proper size of cable according to an actual condition.

### Signal Cable Specifications

Terminal specifications		Cable specifications
Terminal block screw diameter	Recommended crimped terminal	0.75 mm <sup>2</sup> (AWG18) Shielded cable
M3	Y-shape crimped terminal 1.25Y-3	

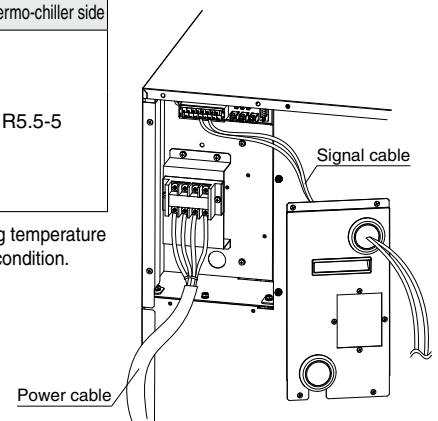

## Operation Display Panel

The basic operation of this unit is controlled through the operation display panel on the front of the product.

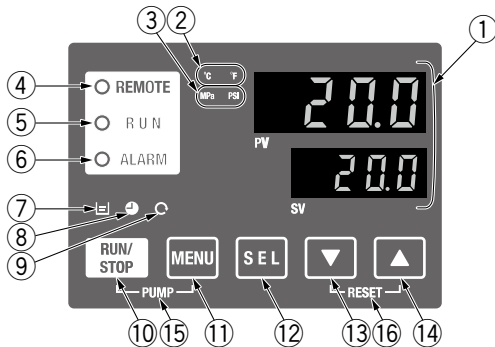

No.	Description	Function
①	<b>Digital display</b> (7 segment, 4 digits)	PV Displays the circulating fluid current discharge temperature and pressure and alarm codes and other menu items (codes). SV Displays the circulating fluid discharge temperature and the set values of other menus.
②	[°C] [°F] lamp	Equipped with a unit conversion function. Displays the unit of displayed temperature (default setting: °C).
③	[MPa] [PSI] lamp	Equipped with a unit conversion function. Displays the unit of displayed pressure (default setting: MPa).
④	[REMOTE] lamp	Enables remote operation (start and stop) by communication. Lights up during remote operation.
⑤	[RUN] lamp	Lights up when the product is started, and goes off when it is stopped. Flashes during stand-by for stop or anti-freezing function, or independent operation of the pump.
⑥	[ALARM] lamp	Flashes with buzzer when alarm occurs.
⑦	[L] lamp	Lights up when the surface of the fluid level indicator falls below the L level.
⑧	[⏰] lamp	Equipped with a timer for start and stop. Lights up when this function is operated.
⑨	[⏻] lamp	Equipped with a power failure auto-restart function, which restarts the product automatically after stopped due to a power failure. Lights up when this function is operated.
⑩	[RUN/STOP] key	Makes the product start or stop.
⑪	[MENU] key	Shifts the main menu (display screen of circulating fluid discharge temperature and pressure) and other menus (for monitoring and entry of set values).
⑫	[SEL] key	Changes the item in menu and enters the set value.
⑬	[▼] key	Decreases the set value.
⑭	[▲] key	Increases the set value.
⑮	[PUMP] key	Press the [MENU] and [RUN/STOP] keys simultaneously. The pump starts running independently to make the product ready for start-up (release the air).
⑯	[RESET] key	Press the [▼] and [▲] keys simultaneously. The alarm buzzer is stopped and the [ALARM] lamp is reset.

## Alarm

This unit has alarms as standard, and displays each of them by its alarm code on the PV screen with the [ALARM] lamp ([LOW LEVEL] lamp) lit up on the operation display panel. The alarm can be read out through communication.

Code	Alarm message
AL01	Low level in tank
AL02	High circulating fluid discharge temp.
AL03	Circulating fluid discharge temp. rise
AL04	Circulating fluid discharge temp. drop
AL05	High circulating fluid return temp.
AL06	High circulating fluid discharge pressure
AL07	Abnormal pump operation
AL08	Circulating fluid discharge pressure rise
AL09	Circulating fluid discharge pressure drop
AL10	High compressor intake temp.
AL11	Low compressor intake temp.
AL12	Low super heat temp.
AL13	High compressor discharge pressure
AL15	Refrigeration circuit pressure (high pressure side) drop
AL16	Refrigeration circuit pressure (low pressure side) rise

Code	Alarm message
AL17	Refrigeration circuit pressure (low pressure side) drop
AL18	Compressor running failure
AL19	Communication error
AL20	Memory error
AL21	DC line fuse cut
AL22	Circulating fluid discharge temp. sensor failure
AL23	Circulating fluid return temp. sensor failure
AL24	Compressor intake temp. sensor failure
AL25	Circulating fluid discharge pressure sensor failure
AL26	Compressor discharge pressure sensor failure
AL27	Compressor intake pressure sensor failure
AL28	Pump maintenance
AL29	Fan maintenance
AL30	Compressor maintenance
AL31	Contact input 1 signal detection

Code	Alarm message
AL32	Contact input 2 signal detection
AL37	Compressor discharge temp. sensor failure
AL38	Compressor discharge temp. rise
AL40	Dustproof filter maintenance*1
AL41	Power stoppage
AL42	Compressor waiting
AL43	Fan failure*1
AL45	Compressor over current
AL47	Pump over current
AL50	Incorrect phase error
AL51	Phase board over current

\*1 Does not occur on the product of water-cooled refrigeration type.

\* For details, read the Operation Manual.

## List of Function

No.	Function	Outline
1	<b>Main display</b>	Displays the current and set temperature of the circulating fluid, discharge pressure of the circulating fluid. Changes the circulating fluid set temperature.
2	<b>Alarm display menu</b>	Indicates alarm number when an alarm occurs.
3	<b>Inspection monitor menu</b>	Product temperature, pressure and accumulated operating time can be checked as daily inspection. Use these for daily inspection.
4	<b>Key-lock</b>	Keys can be locked so that set values cannot be changed by operator error.
5	<b>Timer for operation start/stop</b>	Timer is used to set the operation start/stop.
6	<b>Signal for the completion of preparation</b>	A signal is output when the circulating fluid temperature reaches the set temperature, when using contact input/output and serial communication.
7	<b>Offset function</b>	Use this function when there is a temperature offset between the discharge temperature of the thermo-chiller and user's equipment.
8	<b>Reset after power failure</b>	Start operation automatically after the power supply is turned on.
9	<b>Key click sound setting</b>	Operation panel key sound can be set on/off.
10	<b>Changing temp. unit</b>	Temperature unit can be changed. Centigrade (°C) ↔ Fahrenheit (°F)
11	<b>Changing pressure unit</b>	Pressure unit can be changed. MPa ↔ PSI
12	<b>Data reset</b>	Functions can be reset to the default settings (settings when shipped from the factory).
13	<b>Accumulation time reset</b>	Reset function when the pump, the fan or the compressor is replaced. Reset the accumulated time here.
14	<b>Anti-freezing function</b>	Circulating fluid is protected from freezing during winter or at night. Set beforehand if there is a risk of freezing.
15	<b>Warming-up function</b>	When circulating fluid temperature rising time at starting needs shortening during winter or at night, set beforehand.
16	<b>Alarm buzzer sound setting</b>	Alarm sound can be set to on/off.
17	<b>Alarm customizing</b>	Operation during alarm condition and threshold values can be changed depending on the alarm type.
18	<b>Communication</b>	This function is used for contact input/output or serial communication.

For details, refer to the Operation Manual. Please download it via our website, <https://www.smcworld.com>

## Communication Functions

### Contact Input/Output

Item	Specifications												
<b>Connector type</b>	M3 terminal block												
<b>Input signal</b>	<b>Insulation method</b>	Photocoupler											
	<b>Rated input voltage</b>	24 VDC											
	<b>Operating voltage range</b>	21.6 to 26.4 VDC											
	<b>Rated input current</b>	5 mA TYP											
	<b>Input impedance</b>	4.7 kΩ											
<b>Contact output signal</b>	<b>Rated load voltage</b>	48 VAC or less/30 VDC or less											
	<b>Maximum load current</b>	500 mA AC/DC (Resistance load)											
	<b>Minimum load current</b>	5 VDC 10 mA											
<b>Output voltage</b>	24 VDC ±10% 500 mA MAX (No inductive load)												
<b>Circuit diagram</b>	<table border="1" style="margin-left: auto; margin-right: auto;"> <thead> <tr> <th>Signal description</th> <th>Default setting*1</th> </tr> </thead> <tbody> <tr> <td>Contact input signal 2</td> <td>—</td> </tr> <tr> <td>Contact input signal 1</td> <td>Run/stop signal input</td> </tr> <tr> <td>Contact output signal 3</td> <td>Alarm status signal output</td> </tr> <tr> <td>Contact output signal 2</td> <td>Remote status signal output</td> </tr> <tr> <td>Contact output signal 1</td> <td>Operation status signal output</td> </tr> </tbody> </table>	Signal description	Default setting*1	Contact input signal 2	—	Contact input signal 1	Run/stop signal input	Contact output signal 3	Alarm status signal output	Contact output signal 2	Remote status signal output	Contact output signal 1	Operation status signal output
Signal description	Default setting*1												
Contact input signal 2	—												
Contact input signal 1	Run/stop signal input												
Contact output signal 3	Alarm status signal output												
Contact output signal 2	Remote status signal output												
Contact output signal 1	Operation status signal output												

\*1 The pin numbers and output signals can be set by user. For details, refer to the Operation Manual for communication.

\*2 When using with optional accessories, depending on the accessory, the allowable current of 24 VDC devices will be reduced. Refer to the operation manual of the optional accessories for details.

### Serial Communication

The serial communication (RS-485/RS-232C) enables the following items to be written and read out.

For details, refer to the Operation Manual for communication.

Writing
Run/Stop Circulating fluid temperature setting (SV)

Readout
Circulating fluid present temperature Circulating fluid discharge pressure Status information Alarm occurrence information

Item	Specifications	
<b>Connector type</b>	D-sub 9-pin, Female connector (Mounting screw: M2.6 x 0.45)	
<b>Protocol</b>	Modicon Modbus compliant/Simple communication protocol	
<b>Standards</b>	EIA standard RS-485	EIA standard RS-232C
<b>Circuit diagram</b>		

\* The terminal resistance of RS-485 (120 Ω) can be switched by the operation display panel. For details, refer to the Operation Manual for communication. Do not connect other than in the way shown above, as it can result in failure.

Please download the Operation Manual via our website, <https://www.smcworld.com>



# HRS090 Series Options

\* Options have to be selected when ordering the thermo-chiller. It is not possible to add them after purchasing the unit.

**B** Option symbol

## With Earth Leakage Breaker

HRS090-□□-20-B

● With earth leakage breaker

A leakage breaker is built in to automatically stop the supply power when it has short-circuit, over current or electrical leakage. (For models with power supply specification '-40' or '-46', it is not necessary to select this option because an earth leakage breaker is equipped as standard.)

Applicable model	Rated current [A]	Sensitivity of leak current [mA]	Short circuit display method
HRS090-□□-20-B	30	30	Mechanical button

\* 400/460 V type is equipped as standard.

Earth leakage breaker

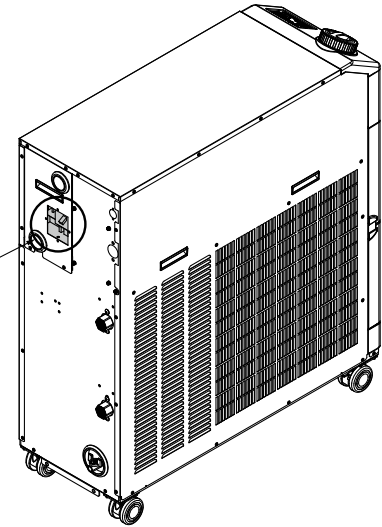

**J** Option symbol

## With Automatic Fluid Fill Function

HRS090-□□-□-J

● With automatic fluid fill function

By installing this at the automatic fluid fill port, the circulating fluid can be automatically supplied to the product using a built-in solenoid valve for filling fluid while the circulating fluid is decreasing.

Applicable model	HRS090-□□-□-J
Fluid fill method	Built-in solenoid valve for automatic fluid filling
Fluid fill pressure [MPa]	0.2 to 0.5
Feed water temperature [°C]	5 to 40

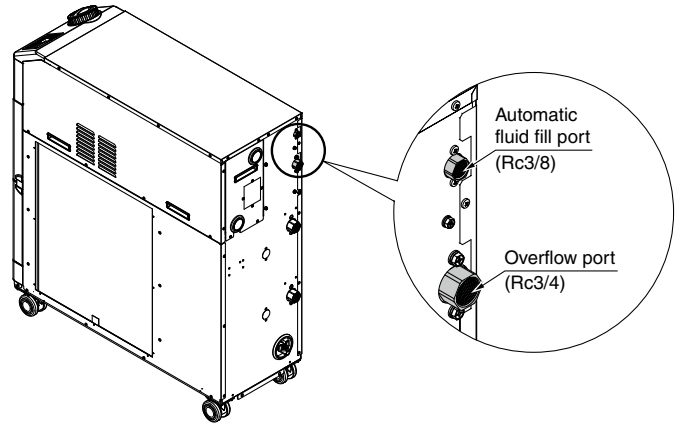

**M** Option symbol

## Applicable to Deionized Water Piping

HRS090-□□-□-M

● Applicable to deionized water piping

Contact material of the circulating fluid circuit is made from non-copper materials.

Applicable model	HRS090-□□-□-M
Contact material for circulating fluid	Stainless steel (including heat exchanger brazing), SiC, Carbon, PP, PE, POM, FKM, NBR, EPDM, PVC, PTFE

\* No change in external dimensions

**W** Option symbol

## SI Unit Only

HRS090-□□-□-W

● SI unit only

The circulating fluid temperature and pressure are displayed in SI units [MPa/°C] only. If this option is not selected, a product with a unit selection function will be provided by default.

\* No change in external dimensions

HRS

HRS-R

HRS090

HRS 100/150

HRS200

HRS090

HRS-H

HRS-E

HRS

HRS

HRS

HRS

HRS

HRS

HECR

HEC

HEB

HED

Technical Data

# HRS090 Series Optional Accessories

## ① Piping Conversion Fitting

This is a fitting to change the port from Rc to G or NPT.

- Circulating fluid outlet, Circulating fluid return port Rc1 → NPT1 or G1
- Drain port Rc1/4 → NPT1/4 or G1/4

(It is not necessary to purchase this when pipe thread type F or N is selected in “How to Order” since it is included in the product.)

Part no.	Contents	Applicable model
HRS-EP018	NPT thread conversion fitting set	HRS090-A-20/40/46
HRS-EP019	G thread conversion fitting set	

Part no.	Contents	Applicable model
HRS-EP022	NPT thread conversion fitting set	HRS090-W-20/40/46
HRS-EP023	G thread conversion fitting set	

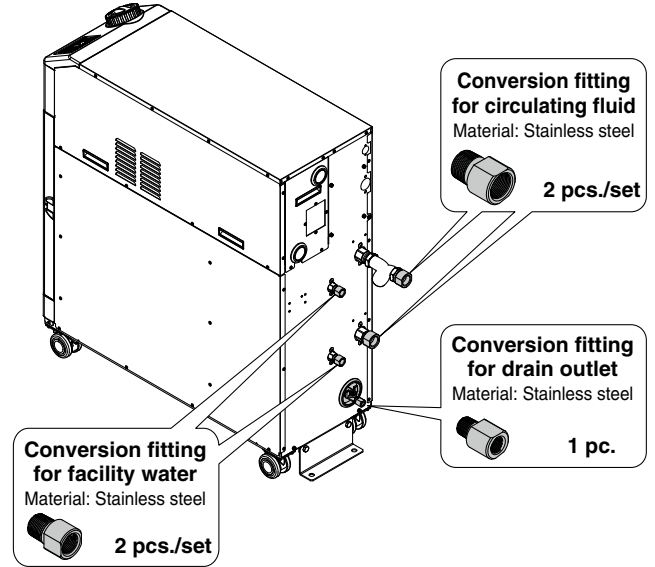
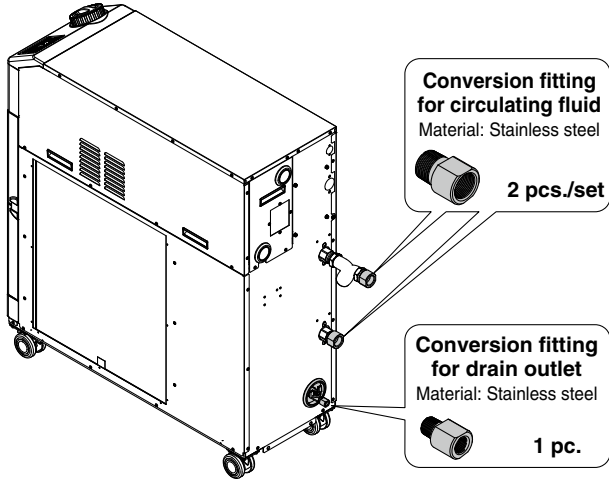

When option J (With automatic fluid fill function) is included, use the following part numbers.

- Automatic fluid fill port Rc3/8 → NPT3/8 or G3/8
- Overflow port Rc3/4 → NPT3/4 or G3/4

\* The conversion fittings for circulating fluid outlet/return port, drain port, facility water inlet/outlet (for water-cooled refrigeration) are also included.

Part no.	Contents	Applicable model
HRS-EP020	NPT thread conversion fitting set	HRS090-A-20/40/46-J
HRS-EP021	G thread conversion fitting set	

Part no.	Contents	Applicable model
HRS-EP024	NPT thread conversion fitting set	HRS090-W-20/40/46-J
HRS-EP025	G thread conversion fitting set	

## ② Bypass Piping Set

When the circulating fluid goes below the minimum operating flow rate (as shown below), cooling capacity will be reduced and the temperature stability will be badly affected. Use the bypass piping set to ensure a circulating fluid flow rate of the minimum operating flow rate or more.

Part no.	Applicable model	Minimum operating flow rate (50/60 Hz) [L/min]
HRS-BP005	HRS090-□□-20/40/46	29/45

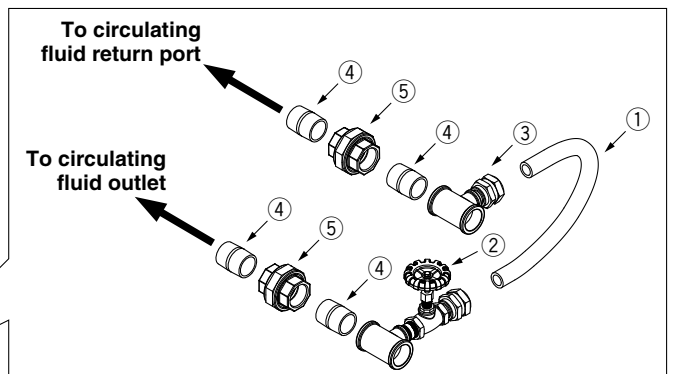
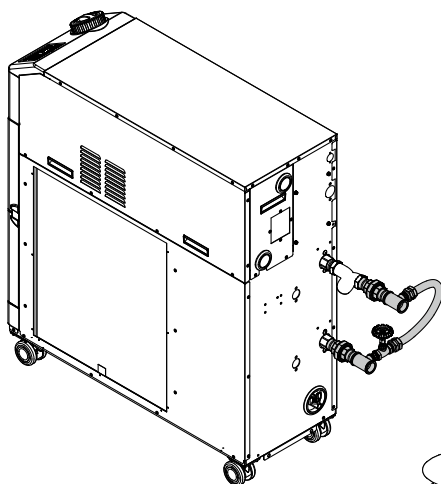

### Parts List

No.	Description
①	Hose (I.D.: 15 mm, Length: 700 mm)
②	Outlet piping assembly (With globe valve)
③	Return piping assembly
④	Barrel nipple (Size: 1 inch) (2 pcs.)
⑤	Union (Size: 1 inch) (2 pcs.)
⑥	Sealant tape
⑦	Operation Manual

### ③ Electric Conductivity Control Set

The set indicates and controls the electric conductivity of the circulating fluid. Refer to the Operation Manual for details.

Part no.	Applicable model
HRS-DI007	HRS090-□□-20/40/46

Measurement range of electric conductivity	2.0 to 48.0 $\mu\text{S/cm}$
Set range of electric conductivity target	5.0 to 45.0 $\mu\text{S/cm}$
Set range of electric conductivity hysteresis	2.0 to 10.0 $\mu\text{S/cm}$
Operating temperature range (Circulating fluid temperature)	5 to 60°C
Power consumption	400 mA or less

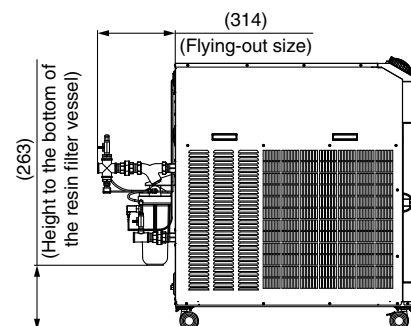
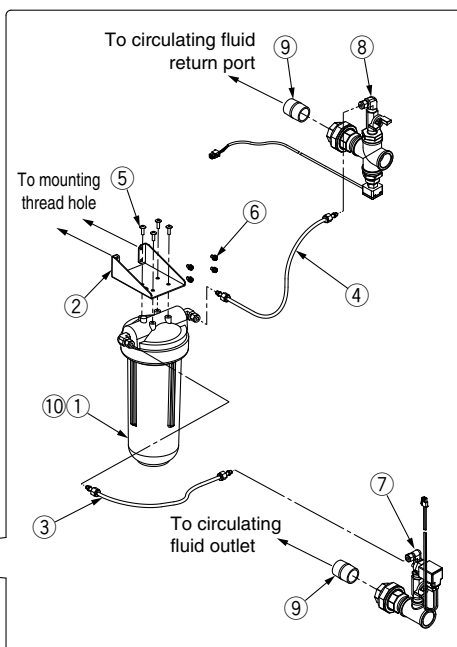
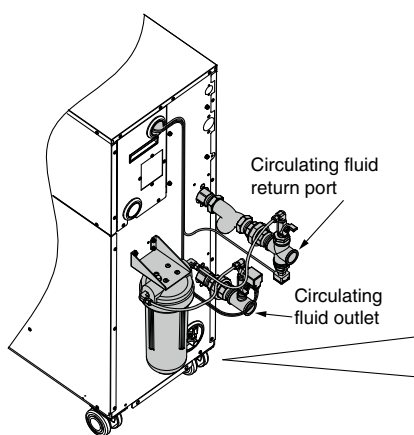

#### Parts List

No.	Description	Fluid contact material	Qty.
①	DI filter vessel	PC, PP	1
②	Mounting bracket	—	1
③	DI filter inlet tube	PFA, POM	1
④	DI filter outlet tube	PFA, POM	1
⑤	Tapping screw (M5 screw)	—	4
⑥	Mounting screw (M5 screw)	—	4
⑦	DI control piping assembly	Stainless steel, EPDM	1
⑧	DI sensor assembly	Stainless steel, PPS	1
⑨	Nipple (Size: 1 inch)	Stainless steel	2
⑩	DI filter cartridge (Part no.: HRS-DF001)*1	PP, PE	1

\*1 The product should be replaced when it can no longer preserve the electrical conductivity set value.

### ④ Particle Filter Set

Removes foreign matter in the circulating fluid. If foreign matter such as scales in the piping enter the circulating fluid, this may cause the pump to malfunction. Therefore, it is strongly recommended to install the particle filter set. This set cannot be directly connected to the thermo-chiller. Install it in the user's piping system. For details, refer to the Operation Manual.

#### Particle Filter Set

HRS-PF005-**H**

#### Accessory

Symbol	Accessory
Nil	None
H	With handle

Fluid	Tap water
Max. operating pressure	0.65 MPa
Operating temperature range	5 to 35°C
Nominal filtration accuracy	5 $\mu\text{m}$
Installation environment	Indoors

#### Parts List

No.	Description	Material	Qty.	Note
①	Body	PC, PP	1	—
②	Element*1	PP	1	—
③	Extension piece	Stainless steel	2	Conversion from NPT to Rc
④	Handle	—	1	When -H is selected
⑤	Sealant tape	PTFE	1	—

\*1 The product should be replaced when the pressure drop reaches 0.1 MPa.

#### Replacement Element

HRS-PF006

The product should be replaced when the pressure drop reaches 0.1 MPa.

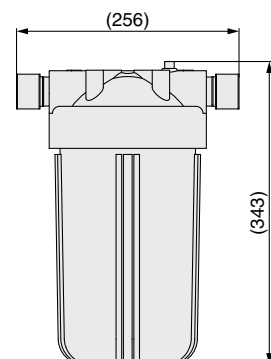
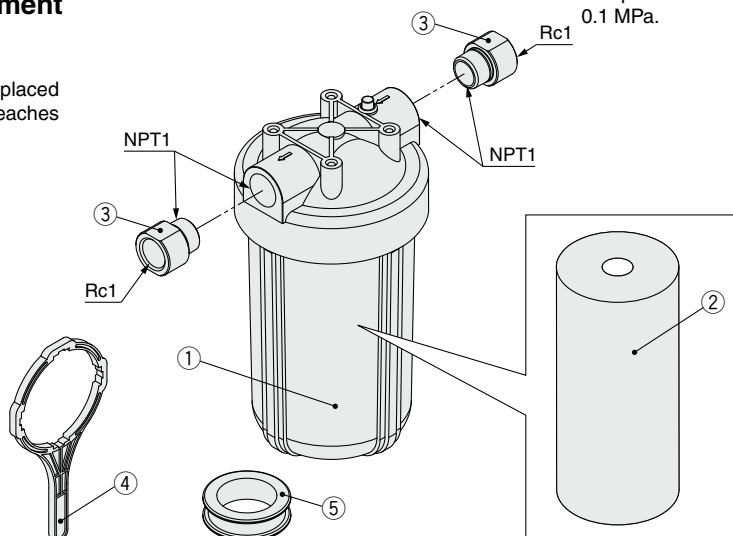

HRS  
HRS-R  
HRS090  
HRS 100/150  
HRS200  
HRS090  
HRSH090  
HRSH  
HRSE  
HRR  
HRL  
HRZ  
HRZD  
HRW  
HECR  
HEC  
HEB  
HED  
Technical Data

# HRS090 Series

## ⑤ Filter for Circulating Fluid Fill Port

Prevents foreign matter from entering the tank when supplying the circulating fluid. Can be used just by fitting into the circulating fluid fill port.

### ■ Filter for circulating fluid fill port HRS-PF007

Material	Stainless steel 304, Stainless steel 316
Mesh size	200

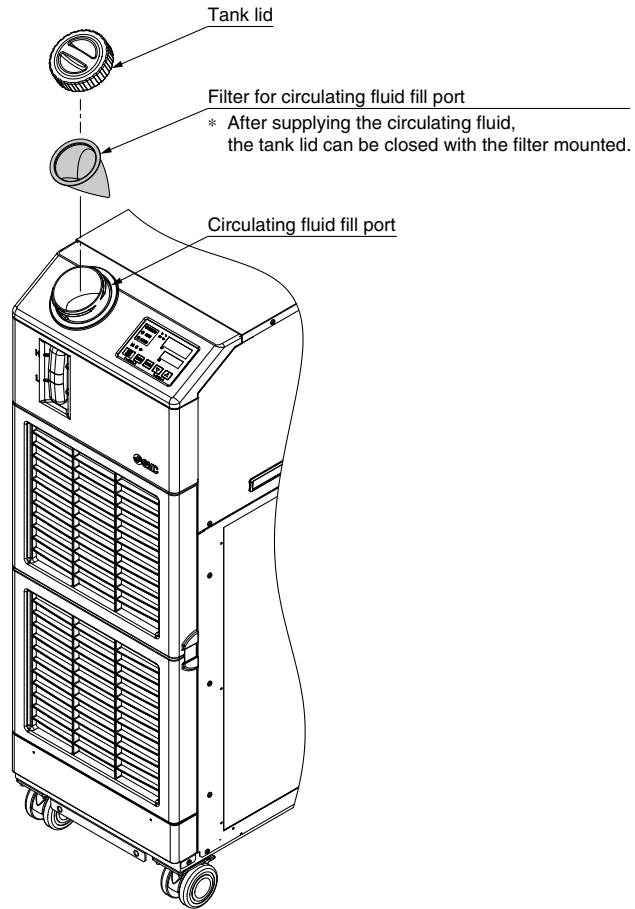

## ⑥ Drain Pan Set (With Water Leakage Sensor)

Drain pan for the thermo-chiller. Liquid leakage from the thermo-chiller can be detected by mounting the attached water leakage sensor. Align the drain pan with the hole in the bottom of the thermo-chiller for installation.

Part no.	Applicable model
HRS-WL003	HRS090-□□-20/40/46

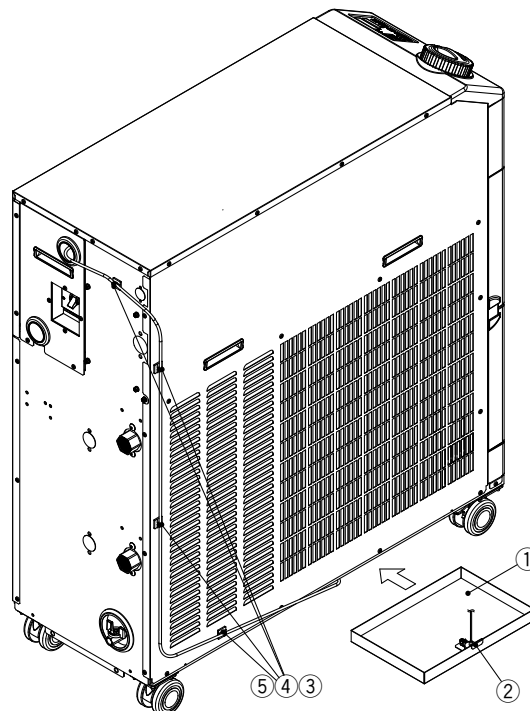

### Parts List

No.	Description
①	Drain pan
②	Water leakage sensor
③	Extension cable
④	Binding band (4 pcs.)
⑤	Cable fixture (4 pcs.)



# HRS090 Series

# Cooling Capacity Calculation

## Required Cooling Capacity Calculation

**Example 1: When the heat generation amount in the user's equipment is known.**

The heat generation amount can be determined based on the power consumption or output of the heat generating area — i.e. the area requiring cooling — within the user's equipment.\*1

① Derive the heat generation amount from the power consumption.

Power consumption **P**: 7 [kW]

$$Q = P = 7 \text{ [kW]}$$

$$\text{Cooling capacity} = \text{Considering a safety factor of 20\%, } 7 \text{ [kW]} \times 1.2 = \mathbf{8.4 \text{ [kW]}}$$

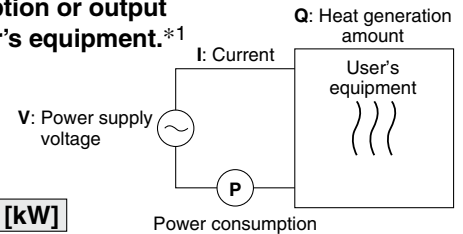

② Derive the heat generation amount from the power supply output.

Power supply output **VI**: 8.8 [kVA]

$$Q = P = V \times I \times \text{Power factor}$$

In this example, using a power factor of 0.85:

$$= 8.8 \text{ [kVA]} \times 0.85 = 7.5 \text{ [kW]}$$

Cooling capacity = Considering a safety factor of 20%,

$$7.5 \text{ [kW]} \times 1.2 = \mathbf{9.0 \text{ [kW]}}$$

③ Derive the heat generation amount from the output.

Output (shaft power, etc.) **W**: 13 [kW]

$$Q = P = \frac{W}{\text{Efficiency}}$$

In this example, using an efficiency of 0.7:

$$= \frac{5.1}{0.7} = 7.3 \text{ [kW]}$$

Cooling capacity = Considering a safety factor of 20%,

$$7.3 \text{ [kW]} \times 1.2 = \mathbf{8.8 \text{ [kW]}}$$

\*1 The examples above calculate the heat generation amount based on the power consumption. The actual heat generation amount may differ due to the structure of the user's equipment. Be sure to check it carefully.

**Example 2: When the heat generation amount in the user's equipment is not known.**

Obtain the temperature difference between inlet and outlet by circulating the circulating fluid inside the user's equipment.

Heat generation amount by user's equipment <b>Q</b>	: Unknown [W] [(J/s)]
Circulating fluid	: Tap water*1
Circulating fluid mass flow rate <b>qm</b>	: ( $= \rho \times qv \div 60$ ) [kg/s]
Circulating fluid density $\rho$	: 1 [kg/L]
Circulating fluid (volume) flow rate <b>qv</b>	: 35 [L/min]
Circulating fluid specific heat <b>C</b>	: $4.186 \times 10^3$ [J/(kg·K)]
Circulating fluid outlet temperature <b>T1</b>	: 293 [K] (20 [°C])
Circulating fluid return temperature <b>T2</b>	: 296 [K] (23 [°C])
Circulating fluid temperature difference $\Delta T$	: 3 [K] ( $= T_2 - T_1$ )
Conversion factor: minutes to seconds (SI units)	: 60 [s/min]

\*1 Refer to page 130 for the typical physical property value of tap water or other circulating fluids.

$$Q = qm \times C \times (T_2 - T_1)$$

$$= \frac{\rho \times qv \times C \times \Delta T}{60} = \frac{1 \times 35 \times 4.186 \times 10^3 \times 3.0}{60}$$

$$= 7325 \text{ [J/s]} \approx 7325 \text{ [W]} = 7.3 \text{ [kW]}$$

Cooling capacity = Considering a safety factor of 20%,

$$7.3 \text{ [kW]} \times 1.2 = \mathbf{8.8 \text{ [kW]}}$$

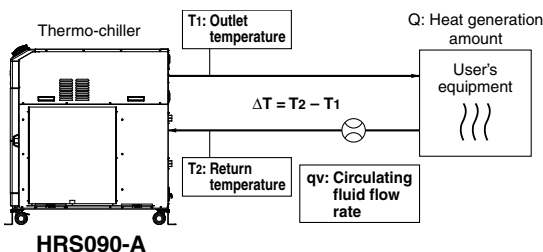

### Example of conventional units (Reference)

Heat generation amount by user's equipment <b>Q</b>	: Unknown [cal/h] → [W]
Circulating fluid	: Tap water*1
Circulating fluid weight flow rate <b>qm</b>	: ( $= \rho \times qv \times 60$ ) [kgf/h]
Circulating fluid weight volume ratio $\gamma$	: 1 [kgf/L]
Circulating fluid (volume) flow rate <b>qv</b>	: 35 [L/min]
Circulating fluid specific heat <b>C</b>	: $1.0 \times 10^3$ [cal/(kgf·°C)]
Circulating fluid outlet temperature <b>T1</b>	: 20 [°C]
Circulating fluid return temperature <b>T2</b>	: 23 [°C]
Circulating fluid temperature difference $\Delta T$	: 3 [°C] ( $= T_2 - T_1$ )
Conversion factor: hours to minutes	: 60 [min/h]
Conversion factor: kcal/h to kW	: 860 [(cal/h)/W]

$$Q = \frac{qm \times C \times (T_2 - T_1)}{860}$$

$$= \frac{\gamma \times qv \times 60 \times C \times \Delta T}{860}$$

$$= \frac{1 \times 35 \times 60 \times 1.0 \times 10^3 \times 3.0}{860}$$

$$\approx 7325 \text{ [W]} = 7.3 \text{ [kW]}$$

Cooling capacity = Considering a safety factor of 20%,

$$7.3 \text{ [kW]} \times 1.2 = \mathbf{8.8 \text{ [kW]}}$$

## Required Cooling Capacity Calculation

**Example 3: When there is no heat generation, and when cooling the object below a certain temperature and period of time.**

Heat quantity by cooled substance (per unit time) **Q** : Unknown [W] ([J/s])  
 Cooled substance : Water  
 Cooled substance mass **m** : (=  $\rho \times V$ ) [kg]  
 Cooled substance density  $\rho$  : 1 [kg/L]  
 Cooled substance total volume **V** : 150 [L]  
 Cooled substance specific heat **C** :  $4.186 \times 10^3$  [J/(kg·K)]  
 Cooled substance temperature when cooling begins **T<sub>0</sub>** : 303 [K] (30 [°C])  
 Cooled substance temperature after t hour **T<sub>t</sub>** : 293 [K] (20 [°C])  
 Cooling temperature difference  $\Delta T$  : 10 [K] (=  $T_0 - T_t$ )  
 Cooling time  $\Delta t$  : 900 [s] (= 15 [min])

\* Refer to the following for the typical physical property values by circulating fluid.

$$Q = \frac{m \times C \times (T_0 - T_t)}{\Delta t} = \frac{\rho \times V \times C \times \Delta T}{\Delta t}$$

$$= \frac{1 \times 150 \times 4.186 \times 10^3 \times 10}{900} = 6977 \text{ [J/s]} \approx 7.0 \text{ [kW]}$$

Cooling capacity = Considering a safety factor of 20%,  
 $7.0 \text{ [kW]} \times 1.2 = \mathbf{8.4 \text{ [kW]}}$

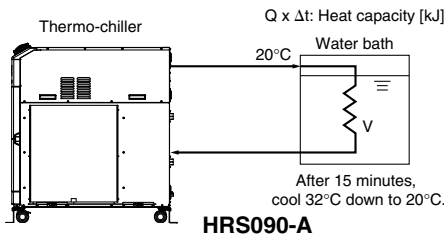

### Example of conventional units (Reference)

Heat quantity by cooled substance (per unit time) **Q** : Unknown [cal/h] → [W]  
 Cooled substance : Water  
 Cooled substance weight **m** : (=  $\rho \times V$ ) [kgf]  
 Cooled substance weight volume ratio  $\gamma$  : 1 [kgf/L]  
 Cooled substance total volume **V** : 150 [L]  
 Cooled substance specific heat **C** :  $1.0 \times 10^3$  [cal/(kgf·°C)]  
 Cooled substance temperature when cooling begins **T<sub>0</sub>** : 30 [°C]  
 Cooled substance temperature after t hour **T<sub>t</sub>** : 20 [°C]  
 Cooling temperature difference  $\Delta T$  : 10 [°C] (=  $T_0 - T_t$ )  
 Cooling time  $\Delta t$  : 15 [min]  
 Conversion factor: hours to minutes : 60 [min/h]  
 Conversion factor: kcal/h to kW : 860 [(cal/h)/W]

$$Q = \frac{m \times C \times (T_0 - T_t)}{\Delta t \times 860} = \frac{\gamma \times V \times 60 \times C \times \Delta T}{\Delta t \times 860}$$

$$= \frac{1 \times 150 \times 60 \times 1.0 \times 10^3 \times 10}{15 \times 860}$$

$$\approx 6977 \text{ [W]} = 7.0 \text{ [kW]}$$

Cooling capacity = Considering a safety factor of 20%,  
 $7.0 \text{ [kW]} \times 1.2 = \mathbf{8.4 \text{ [kW]}}$

\* This is the calculated value by changing the fluid temperature only. Thus, it varies substantially depending on the water bath or piping shape.

## Precautions on Cooling Capacity Calculation

### 1. Heating capacity

When the circulating fluid temperature is set above room temperature, it needs to be heated by the thermo-chiller. The heating capacity depends on the circulating fluid temperature. Consider the radiation rate and heat capacity of the user's equipment and check beforehand if the required heating capacity is provided.

### 2. Pump capacity

#### <Circulating fluid flow rate>

Circulating fluid flow rate varies depending on the circulating fluid discharge pressure. Consider the installation height difference between the thermo-chiller and the user's equipment, and the piping resistance such as circulating fluid pipings, or piping size, or piping curves in the machine. Check beforehand if the required flow is achieved, using the pump capacity curves.

#### <Circulating fluid discharge pressure>

Circulating fluid discharge pressure has the possibility to increase up to the maximum pressure in the pump capacity curves. Check beforehand if the circulating fluid pipings or circulating fluid circuit of the user's equipment are fully durable against this pressure.

## Circulating Fluid Typical Physical Property Values

### 1. This catalog uses the following values for density and specific heat in calculating the required cooling capacity.

Density  $\rho$ : 1 [kg/L] (or, using conventional units, weight volume ratio  $\gamma = 1$  [kgf/L])

Specific heat **C**:  $4.19 \times 10^3$  [J/(kg·K)] (or, using conventional units,  $1 \times 10^3$  [cal/(kgf·°C)])

### 2. Values for density and specific heat change slightly according to temperature shown below. Use this as a reference.

#### Water

Physical property value Temperature	Density $\rho$ [kg/L]	Specific heat C [J/(kg·K)]	Conventional units	
			Weight volume ratio $\gamma$ [kgf/L]	Specific heat C [cal/(kgf·°C)]
5°C	1.00	$4.2 \times 10^3$	1.00	$1 \times 10^3$
10°C	1.00	$4.19 \times 10^3$	1.00	$1 \times 10^3$
15°C	1.00	$4.19 \times 10^3$	1.00	$1 \times 10^3$
20°C	1.00	$4.18 \times 10^3$	1.00	$1 \times 10^3$
25°C	1.00	$4.18 \times 10^3$	1.00	$1 \times 10^3$
30°C	1.00	$4.18 \times 10^3$	1.00	$1 \times 10^3$
35°C	0.99	$4.18 \times 10^3$	0.99	$1 \times 10^3$
40°C	0.99	$4.18 \times 10^3$	0.99	$1 \times 10^3$

#### 15% Ethylene Glycol Aqueous Solution

Physical property value Temperature	Density $\rho$ [kg/L]	Specific heat C [J/(kg·K)]	Conventional units	
			Weight volume ratio $\gamma$ [kgf/L]	Specific heat C [cal/(kgf·°C)]
5°C	1.02	$3.91 \times 10^3$	1.02	$0.93 \times 10^3$
10°C	1.02	$3.91 \times 10^3$	1.02	$0.93 \times 10^3$
15°C	1.02	$3.91 \times 10^3$	1.02	$0.93 \times 10^3$
20°C	1.01	$3.91 \times 10^3$	1.01	$0.93 \times 10^3$
25°C	1.01	$3.91 \times 10^3$	1.01	$0.93 \times 10^3$
30°C	1.01	$3.91 \times 10^3$	1.01	$0.94 \times 10^3$
35°C	1.01	$3.91 \times 10^3$	1.01	$0.94 \times 10^3$
40°C	1.01	$3.92 \times 10^3$	1.01	$0.94 \times 10^3$

\* Shown above are reference values. Contact circulating fluid supplier for details.



# HRS090 Series

## Specific Product Precautions 1

Be sure to read this before handling the products. Refer to page 513 for safety instructions and pages 514 to 517 for temperature control equipment precautions.

### Design

#### ⚠ Warning

##### 1. This catalog shows the specifications of a single unit.

1. Check the specifications of the single unit (contents of this catalog) and thoroughly consider the adaptability between the user's system and this unit.
2. Although a protection circuit as a single unit is installed, prepare a drain pan, water leakage sensor, discharge air facility, and emergency stop equipment, depending on the user's operating conditions. Also, the user is requested to carry out a safety design for the whole system.

##### 2. When attempting to cool areas that are open to the atmosphere (tanks, pipes), plan your piping system accordingly.

When cooling open-air external tanks, arrange the piping so that there are coil pipes for cooling inside the tanks and to carry back the entire flow volume of circulating fluid that is released.

##### 3. Use non-corrosive materials for circulating fluid contact parts.

The recommended circulating fluid is tap water or 15% ethylene glycol aqueous solution. Using corrosive materials such as aluminum or iron for fluid contact parts such as piping may cause clogging or leakage in the circulating fluid circuit. Therefore, take sufficient care when selecting fluid contact part materials such as piping.

##### 4. Design the piping so that no foreign matter enters the chiller.

If foreign matter, such as scales in the piping, enters the circulating fluid, this may cause the pump to malfunction. Therefore, it is strongly recommended to install the particle filter.

##### 5. The facility water outlet temperature (water-cooled type) may increase up to around 60°C.

When selecting the facility water pipings, consider the suitability for temperature.

### Selection

#### ⚠ Warning

##### Model selection

When selecting a thermo-chiller model, the amount of heat generation from the user's equipment must be known. Obtain this value, referring to "Cooling Capacity Calculation" on pages 129 and 130 before selecting a model.

### Handling

#### ⚠ Warning

##### Thoroughly read the operation manual.

Read the operation manual completely before operation, and keep the manual where it can be referred to as necessary.

### Operating Environment/Storage Environment

#### ⚠ Warning

##### 1. Do not use in the following environment as it will lead to a breakdown.

1. Outdoors
2. In locations where water, water vapor, salt water, and oil may splash on the product.
3. In locations where there are dust and particles.
4. In locations where corrosive gases, organic solvents, chemical fluids, or flammable gases are present. (This product is not explosion proof.)
5. In locations where the ambient temperature/humidity exceeds the limits as mentioned below or where condensation occurs.

During transportation/storage: -15°C to 50°C, 15% to 85%  
(But as long as water or circulating fluid are not left inside the pipings)

During operation: 5°C to 45°C, 30% to 70%  
(However, use a 15% ethylene glycol aqueous solution if operating in a place where the ambient temperature or circulating fluid temperature is 10°C or less.)

6. In locations where condensation may occur.
7. In locations which receive direct sunlight or radiated heat.
8. In locations where there is a heat source nearby and the ventilation is poor.
9. In locations where temperature substantially changes.
10. In locations where strong magnetic noise occurs.  
(In locations where strong electric fields, strong magnetic fields and surge voltage occur.)
11. In locations where static electricity occurs, or conditions which make the product discharge static electricity.
12. In locations where high frequency occurs.
13. In locations where damage is likely to occur due to lightning.
14. In locations at an altitude of 3000 m or higher (Except during storage and transportation)

\* For altitudes of 1000 m or higher

Because of lower air density, the heat radiation efficiencies of the devices in the product will be lower in the location at an altitude of 1000 m or higher. Therefore, the maximum ambient temperature to use and the cooling capacity will lower according to the descriptions in the table below.

Select the thermo-chiller considering the descriptions.

- ① Upper limit of ambient temperature: Use the product in ambient temperature of the described value or lower at each altitude.
- ② Cooling capacity coefficient: The product's cooling capacity will lower to one that multiplied by the described value at each altitude.

Altitude [m]	① Upper limit of ambient temperature [°C]	② Cooling capacity coefficient
Less than 1000 m	45	1.00
Less than 1500 m	42	0.85
Less than 2000 m	38	0.80
Less than 2500 m	35	0.75
Less than 3000 m	32	0.70

15. In locations where strong impacts or vibrations occur.
16. In locations where a massive force strong enough to deform the product is applied or a weight from a heavy object is applied.
17. In locations where there is not sufficient space for maintenance.
18. Bevelled place
19. Insects or plants may enter the unit.

##### 2. The product is not designed for clean room usage. It generates particles internally.





# HRS090 Series Specific Product Precautions 2

Be sure to read this before handling the products. Refer to page 513 for safety instructions and pages 514 to 517 for temperature control equipment precautions.

## Transportation/Carriage/Movement

### Warning

1. This product is heavy. Pay attention to safety and the position of the product when it is transported, carried, and moved.
2. Read the operation manual carefully before moving the product after unpacking.

### Caution

1. Never put the product down on its side as this may cause a failure.

The product will be delivered in the packaging shown below.

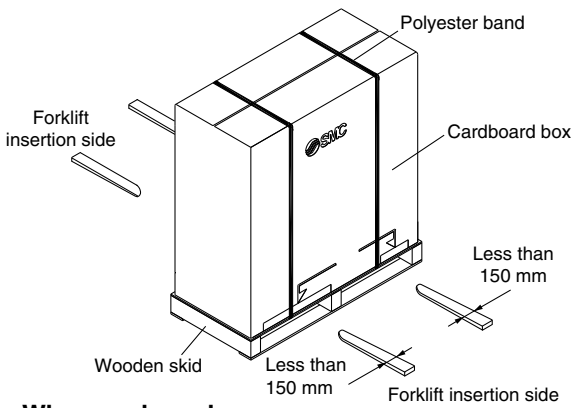

#### <When packaged>

Model	Weight [kg]	Dimensions [mm]
HRS090-A-20/40	171	Height 1320 x Width 580 x Depth 1240
HRS090-W-20/40	159	

### 2. Transporting with forklift

1. A licensed driver should drive the forklift.
2. Insert the fork to the place specified on the label. The fork should reach through to the other side of the product.
3. Be careful not to bump the fork to the cover panel or piping ports.

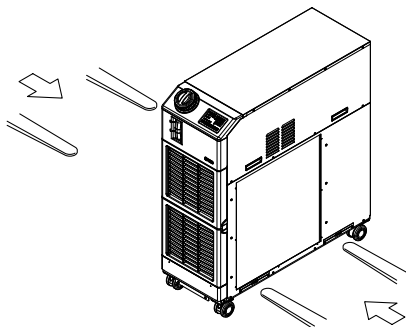

### 3. Transporting with casters

1. This product is heavy and should be moved by at least two people to avoid falling.
2. Do not grip the piping port on the back side or the handles of the panel.
3. Do not pass over bumps, etc. with the casters.

### Caution

If this product is to be transported after delivery, please use the original packaging the product was delivered in. If other packaging is to be used, carefully package the product so as to prevent the product from incurring any damage during transport.

## Installation

### Warning

1. Do not use the product outdoors.
2. Do not place heavy objects on top of this product, or step on it.  
The external panel can be deformed and danger can result.

### Caution

1. Install on a rigid floor which can withstand this product's weight.
2. Refer to the operation manual for this product, and secure an installation space that is necessary for the maintenance and ventilation.

#### <Air-cooled refrigeration>

1. The air-cooled type product exhausts heat using the fan that is mounted to the product. If the product is operated with insufficient ventilation, ambient temperature may exceed 45°C, and this will affect the performance and life of the product. To prevent this ensure that suitable ventilation is available (see below).
2. For installation indoors, ventilation ports and a ventilation fan should be equipped as needed.

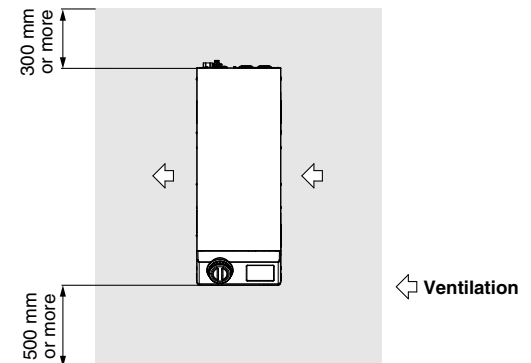
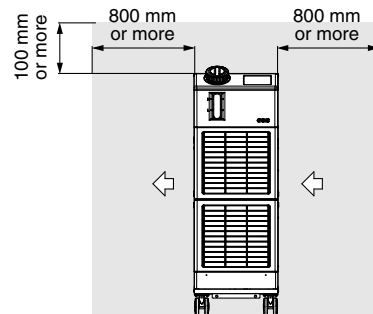

3. If it is impossible to exhaust heat from the installation area indoors, or when the installation area is conditioned, provide a duct for heat exhaustion to the air outlet port of this product for ventilation. Do not mount the inlet of the duct (flange) directly to the air vent of the product, and keep a space larger than the diameter of the duct. Additionally, consider the resistance of the duct when making the air vent port for the duct.

#### <Heat radiation amount/Required ventilation rate>

Model	Heat radiation amount [kW]	Required ventilation rate [m³/min]	
		Differential temp. of 3°C between inside and outside of installation area	Differential temp. of 6°C between inside and outside of installation area
HRS090-A-20/40/46	17	290	145

HRS

HRS-R

HRS090

HRS 100/150

HRS200

HRS090

HRS

HRS

HRS

HRR

HRL

HRZ

HRZD

HRW

HECR

HEC

HEB

HED

Technical Data



# HRS090 Series

## Specific Product Precautions 3

Be sure to read this before handling the products. Refer to page 513 for safety instructions and pages 514 to 517 for temperature control equipment precautions.

### Piping

#### ⚠ Caution

1. The circulating fluid and facility water piping should be prepared by the customer with consideration of the operating pressure, temperature, and circulating fluid/facility compatibility.

If the operating performance is not sufficient, the pipings may burst during operation. Also, the use of corrosive materials such as aluminum or iron for fluid contact parts, such as piping, may not only lead to clogging or leakage in the circulating fluid and facility water circuits but also refrigerant leakage and other unexpected problems. Provide protection against corrosion when you use the product.

2. Select the piping port size which can exceed the rated flow. For the rated flow, refer to the pump capacity table.
3. When tightening at the drain port of this product, use a pipe wrench to clamp the connection ports.
4. For the circulating fluid piping connection, install a drain pan and wastewater collection pit just in case the circulating fluid may leak.
5. This product series are constant-temperature fluid circulating machines with built-in tanks. Do not install equipment on your system side such as pumps that forcibly return the circulating fluid to the unit. Also, if you attach an external tank that is open to the air, it may become impossible to circulate the circulating fluid. Proceed with caution.

6. The facility water flow rate is adjusted automatically according to the operating conditions. In addition, the facility water return temperature is 60°C at maximum.

### Circulating Fluid

#### ⚠ Caution

4. When using ethylene glycol aqueous solution, maintain a maximum concentration of 15%.

Overly high concentrations can cause a pump overload. Low concentrations, however, can lead to freezing when circulating fluid temperature is 10°C or lower and cause the thermo-chiller to break down.

5. When deionized water is used, the electric conductivity should be 1 μS/cm or higher (Electric resistivity: 1 MΩ·cm or lower).

### Electrical Wiring

#### ⚠ Warning

Grounding should never be connected to a water line, gas line or lightning rod.

#### ⚠ Caution

1. Power supply and communication cables should be prepared by user.
2. Provide a stable power supply which is not affected by surge or distortion.

If the voltage increase ratio ( $dV/dt$ ) at the zero cross should exceed 40 V/200 μsec., it may result in malfunction.

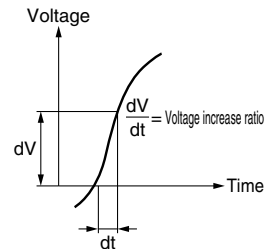

### Circulating Fluid

#### ⚠ Caution

1. Avoid oil or other foreign matter entering the circulating fluid.
2. When water is used as a circulating fluid, use tap water that conforms to the appropriate water quality standards.

Use tap water that conforms to the standards shown below (including water used for dilution of ethylene glycol aqueous solution).

#### Tap Water (as a Circulating Fluid) Quality Standards

The Japan Refrigeration and Air Conditioning Industry Association

JRA GL-02-1994 "Cooling water system – Circulation type – Make-up water"

	Item	Unit	Standard value	Influence	
				Corrosion	Scale generation
Standard item	pH (at 25°C)	—	6.0 to 8.0	○	○
	Electric conductivity (25°C)	[μS/cm]	100*1 to 300*1	○	○
	Chloride ion (Cl <sup>-</sup> )	[mg/L]	50 or less	○	
	Sulfuric acid ion (SO <sub>4</sub> <sup>2-</sup> )	[mg/L]	50 or less	○	
	Acid consumption amount (at pH4.8)	[mg/L]	50 or less		○
	Total hardness	[mg/L]	70 or less		○
	Calcium hardness (CaCO <sub>3</sub> )	[mg/L]	50 or less		○
Reference item	Ionic state silica (SiO <sub>2</sub> )	[mg/L]	30 or less		○
	Iron (Fe)	[mg/L]	0.3 or less	○	○
	Copper (Cu)	[mg/L]	0.1 or less	○	
	Sulfide ion (S <sub>2</sub> <sup>-</sup> )	[mg/L]	Should not be detected.	○	
	Ammonium ion (NH <sub>4</sub> <sup>+</sup> )	[mg/L]	0.1 or less	○	
	Residual chlorine (Cl)	[mg/L]	0.3 or less	○	
	Free carbon (CO <sub>2</sub> )	[mg/L]	4.0 or less	○	

\*1 In the case of [MΩ·cm], it will be 0.003 to 0.01.

○: Factors that have an effect on corrosion or scale generation.

• Even if the water quality standards are met, complete prevention of corrosion is not guaranteed.

3. Use an ethylene glycol aqueous solution that does not contain additives such as preservatives.



# HRS090 Series Specific Product Precautions 4

Be sure to read this before handling the products. Refer to page 513 for safety instructions and pages 514 to 517 for temperature control equipment precautions.

## Electrical Wiring

### ⚠ Caution

When Option “-B” (With earth leakage breaker) or the HRS090-□-40/46-□ is selected

3. This product is installed with a breaker with the following operating characteristics.

For the user's equipment (inlet side), use a breaker whose operating time is equal to or longer than the breaker of this product. If a breaker with shorter operating time is connected, the user's equipment could be cut off due to the inrush current of the motor of this product.

Option B [With earth leakage breaker]

HRS090-□-40-□

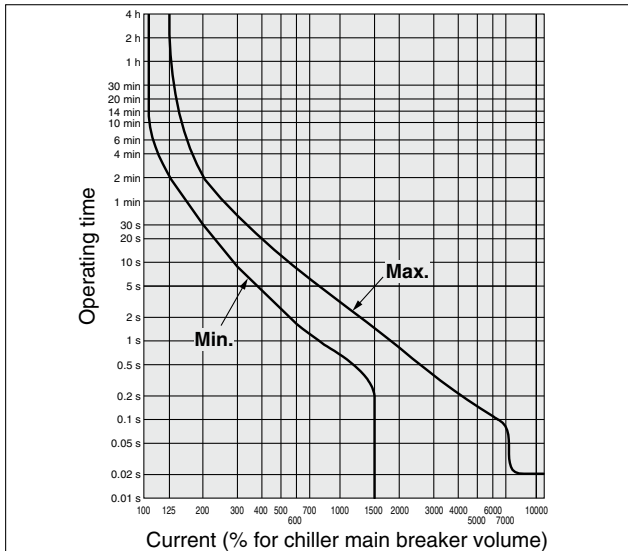

HRS090-□-46-□

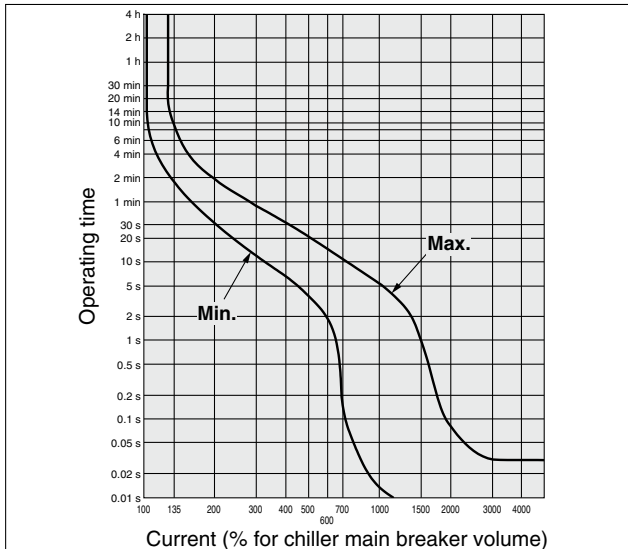

## Facility Water Supply

### ⚠ Warning

<Water-cooled refrigeration>

1. The water-cooled refrigeration type thermo-chiller radiates heat to the facility water. Prepare the facility water system that satisfies the heat radiation and the facility water specifications below.

■ Required facility water system

<Heat radiation amount/Facility water specifications>

Model	Heat radiation [kW]	Facility water specifications
HRS090-W□-□	17	Refer to “Facility water system” in the specifications on page 118.

2. When using tap water as facility water, use tap water that conforms to the appropriate water quality standards.

Use tap water that conforms to the standards shown below. If the water quality standards are not met, clogging or leakage in the facility water piping, or other problems such as refrigerant leakage, etc., may result.

### Tap Water (as Facility Water) Quality Standards

The Japan Refrigeration and Air Conditioning Industry Association

JRA GL-02-1994 “Cooling water system – Circulation type – Circulating water”

Standard item	Item	Unit	Standard value	Influence		
				Corrosion	Scale generation	
Standard item	pH (at 25°C)	—	6.5 to 8.2	○	○	
	Electric conductivity (25°C)	[μS/cm]	100*1 to 800*1	○	○	
	Chloride ion (Cl <sup>-</sup> )	[mg/L]	200 or less	○	○	
	Sulfuric acid ion (SO <sub>4</sub> <sup>2-</sup> )	[mg/L]	200 or less	○	○	
	Acid consumption amount (at pH4.8)	[mg/L]	100 or less	○	○	
	Total hardness	[mg/L]	200 or less	○	○	
	Calcium hardness (CaCO <sub>3</sub> )	[mg/L]	150 or less	○	○	
	Ionic state silica (SiO <sub>2</sub> )	[mg/L]	50 or less	○	○	
	Reference item	Iron (Fe)	[mg/L]	1.0 or less	○	○
		Copper (Cu)	[mg/L]	0.3 or less	○	○
Sulfide ion (S <sub>2</sub> <sup>-</sup> )		[mg/L]	Should not be detected.	○	○	
Ammonium ion (NH <sub>4</sub> <sup>+</sup> )		[mg/L]	1.0 or less	○	○	
Residual chlorine (Cl)		[mg/L]	0.3 or less	○	○	
Free carbon (CO <sub>2</sub> )		[mg/L]	4.0 or less	○	○	

\*1 In the case of [MΩ·cm], it will be 0.001 to 0.01.

○: Factors that have an effect on corrosion or scale generation.

• Even if the water quality standards are met, complete prevention of corrosion is not guaranteed.

3. Set the supply pressure between 0.3 to 0.5 MPa. Ensure a pressure difference at the facility water inlet/outlet of 0.3 MPa or more.

If the supply pressure is high, it will cause water leakage. If the supply pressure and pressure difference at the facility water inlet/outlet is low, it will cause an insufficient flow rate of the facility water, and poor temperature control.



# HRS090 Series

## Specific Product Precautions 5

Be sure to read this before handling the products. Refer to page 513 for safety instructions and pages 514 to 517 for temperature control equipment precautions.

### Operation

#### ⚠ Warning

##### 1. Confirmation before operation

- 1) The fluid level of a tank should be within the specified range of H (High) and L (Low). When exceeding the specified level, the circulating fluid will overflow.
- 2) Remove the air.  
Conduct a trial operation, looking at the fluid level.  
Since the fluid level will go down when the air is removed from the user's piping system, supply water once again when the fluid level is reduced. When there is no reduction in the fluid level, the job of removing the air is completed.  
Pump can be operated independently.

##### 2. Confirmation during operation

- Check the circulating fluid temperature.  
The operating temperature range of the circulating fluid is between 5 and 35°C.  
When the amount of heat generated from the user's equipment is greater than the product's capability, the circulating fluid temperature may exceed this range. Use caution regarding this matter.

##### 3. Emergency stop method

- When an abnormality is confirmed, stop the machine immediately. After stopping operation, disconnect the power supply from the user's equipment.

### Operation Restart Time/Operation and Suspension Frequency

#### ⚠ Caution

1. Wait five minutes or more before restarting operation after it has been stopped. If the operation is restarted within five minutes, the protection circuit may activate and the operation may not start properly.
2. Operation and suspension frequency should not exceed 10 times per day. Frequently switching between operation and suspension may result in the malfunction of the refrigeration circuit.

### Protection Circuit

#### ⚠ Caution

If operating in the below conditions, the protection circuit will activate and an operation may not be performed or will stop.

- Power supply voltage is not within the rated voltage range of ±10%.
- In case the water level inside the tank is reduced abnormally.
- Circulating fluid temperature is too high.
- Compared to the cooling capacity, the heat generation amount of the user's equipment is too high.
- Ambient temperature is too high. (Check the ambient temperature in the specifications.)
- Ventilation hole is clogged with dust or dirt.

### Maintenance

#### ⚠ Caution

##### <Periodical inspection every one month>

##### Clean the ventilation hole.

If the dustproof filter of water-cooled type product becomes clogged with dust or debris, a decline in cooling performance can result. In order to avoid deforming or damaging the dustproof filter, clean it with a long-haired brush or air gun.

##### <Periodical inspection every three months>

##### Inspect the circulating fluid.

1. When using tap water or deionized water
  - Replacement of circulating fluid  
Failure to replace the circulating fluid can lead to the development of bacteria or algae. Replace it regularly depending on your usage conditions.
  - Tank cleaning (same as the HRS series)  
Consider whether dirt, slime or foreign matter may be present in the circulating fluid inside the tank, and carry out regular cleanings of the tank.
2. When using ethylene glycol aqueous solution  
Use a concentration meter to confirm that the concentration does not exceed 15%.  
Dilute or add as needed to adjust the concentration.

##### <Periodical inspection during the winter season>

##### 1. Make water-removal arrangements beforehand.

If there is a risk of the circulating fluid and facility water freezing when the product is stopped, release the circulating fluid and facility water in advance.

##### 2. Consult a professional.

This product has an "anti-freezing function" and "warming-up function." Read the operation manual carefully, and if any additional anti-freezing function (e.g. tape heater) is needed, ask for it from the vendor.

#### ■ Refrigerant with GWP reference

Refrigerant	Global warming potential (GWP)	
	Regulation (EU) No 517/2014 (Based on the IPCC AR4)	Revised Fluorocarbons Recovery and Destruction Law (Japanese law)
R134a	1,430	1,430
R404A	3,922	3,920
R407C	1,774	1,770
R410A	2,088	2,090

- \* This product is hermetically sealed and contains fluorinated greenhouse gases (HFC). When this product is sold on the market in the EU after January 1, 2017, it needs to be compliant with the quota system of the F-Gas Regulation in the EU.
- \* See specification table for refrigerant used in the product.