

Compact Type

Push-lock Type

New

RoHS

# Speed Exhaust Controller with One-touch Fitting

Quick exhaust valve and metering valve are integrated.

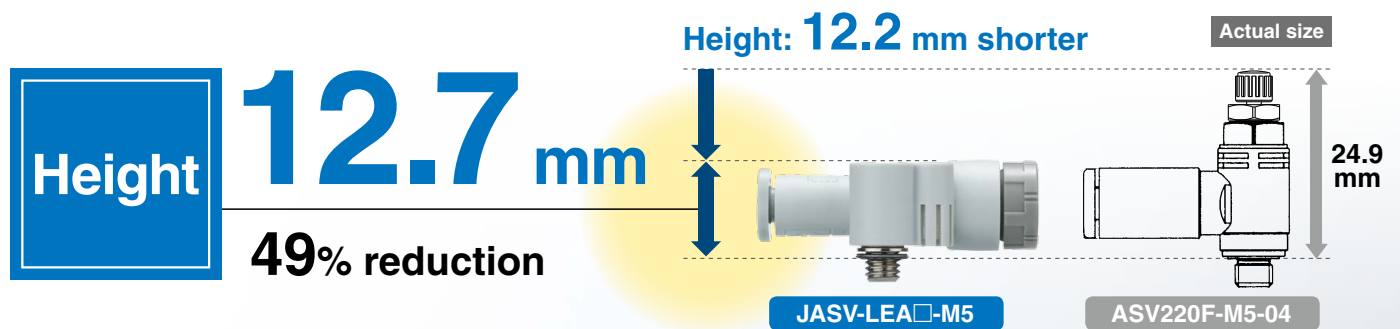

Effective in preventing condensation

p. 1

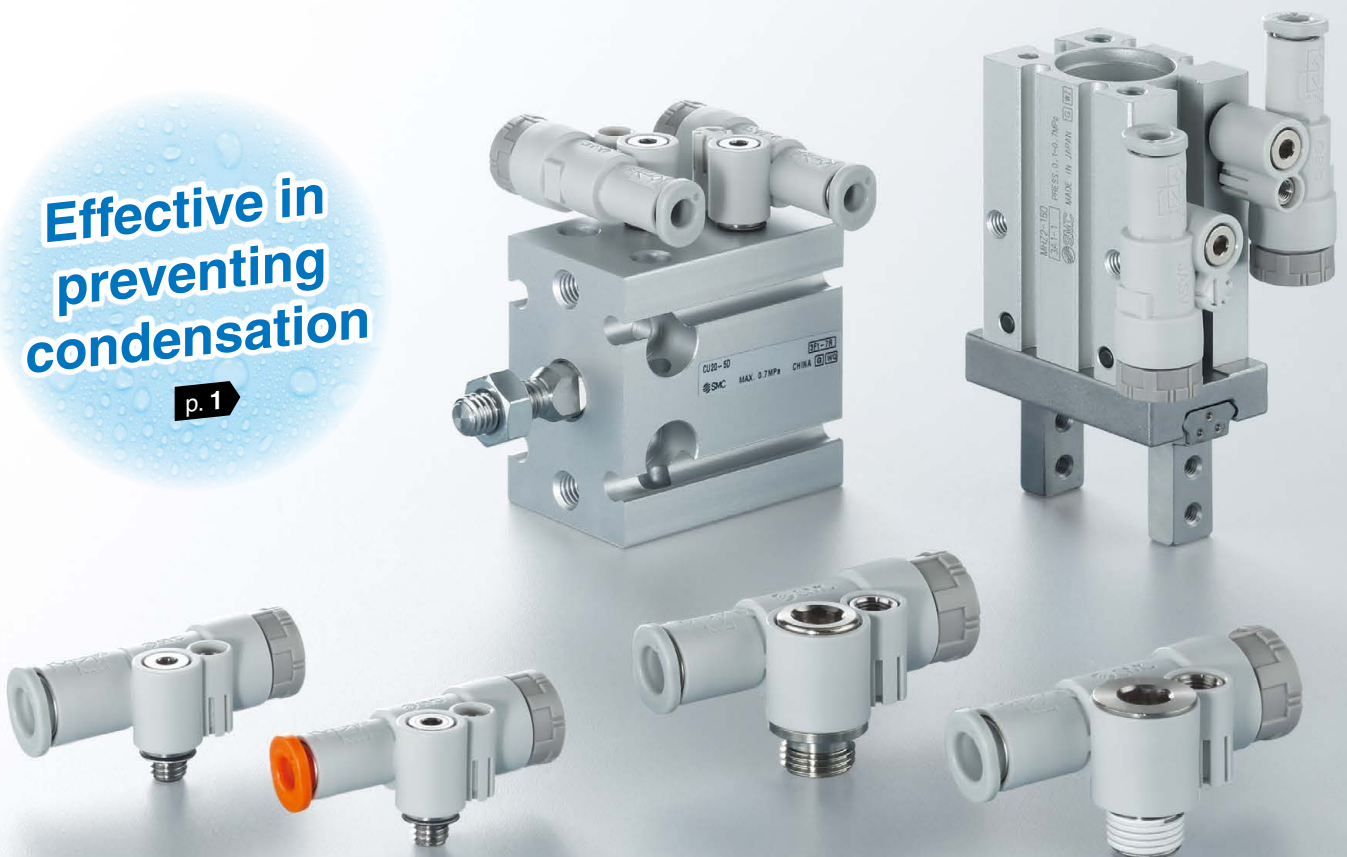

JASV Series

SMC

CAT.ES20-264A

## Effective in preventing condensation

When operating an actuator with a small bore size and a short stroke at a high frequency, dew condensation (water droplets) may occur inside the piping depending on the conditions. Quick exhaust valve and metering valve are integrated. Prevents condensation from generating in the piping by directly exhausting the air in the cylinder to atmosphere



## Applicable for high-speed cylinder actuation

Direct exhaust port relieves air pressure from inside the cylinder regardless of the length of tubing used.

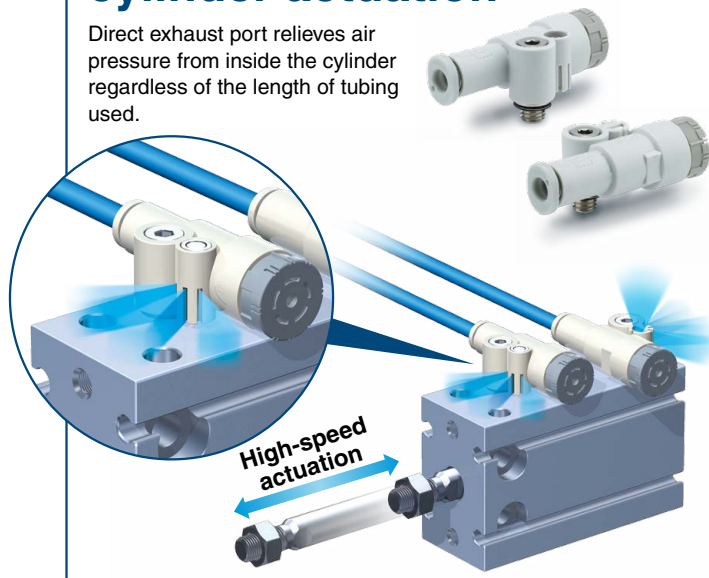

## Possible to adjust flow rate even in narrow spaces

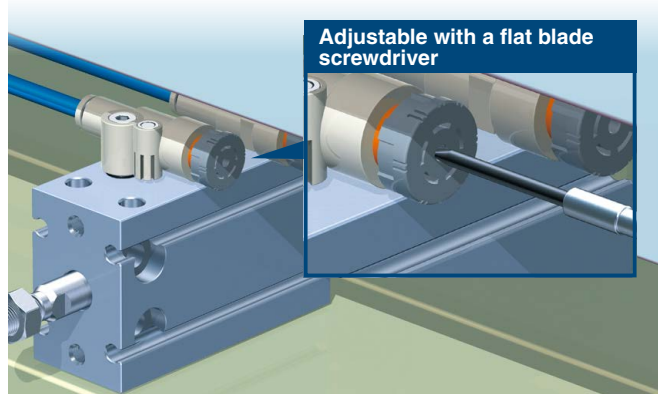

## Easily mounted using a hexagon wrench

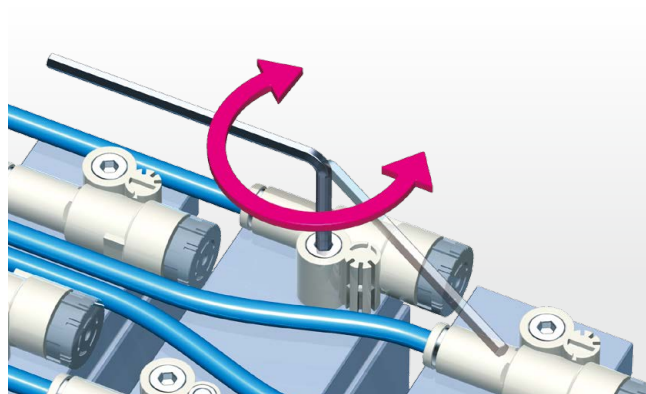

## Variations

Type	Seal method	Port size	Applicable tubing O.D.					
			Metric size			Inch size		
			3.2	4	6	1/8"	5/32"	1/4"
 Elbow type	Gasket seal	M3 x 0.5	●	●				
		M5 x 0.8	●	●	●			
		10-32UNF				●	●	
	Sealant	R1/8		●	●			
		NPT1/8					●	●
	Face seal	G1/8		●	●			

## Easy to use Push-lock type

Locked and unlocked states can be easily confirmed.

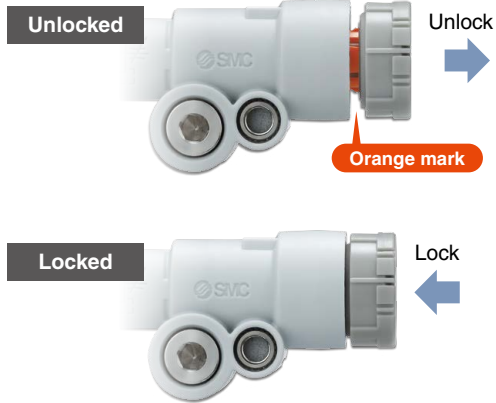

## Easier and consistent flow setting

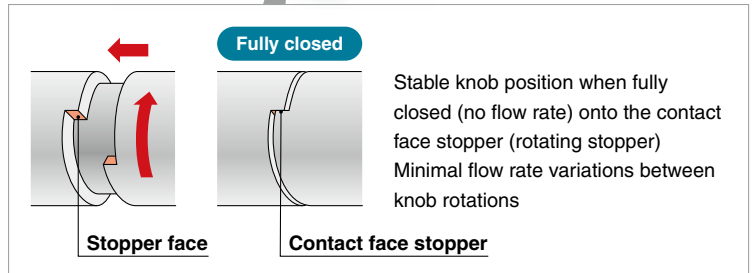
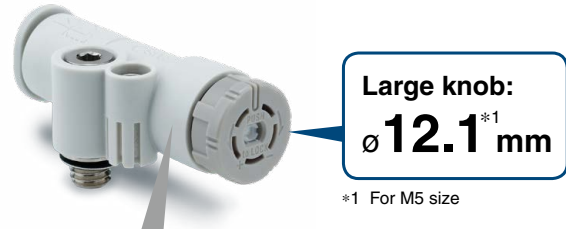

## Available with the mounting stud on the left side or the right side

Right side A type



Left side B type

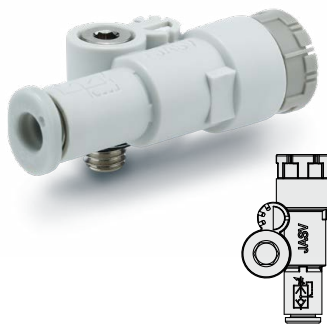

Installation example

For reducing the protrusion of the body over the rod and head ends

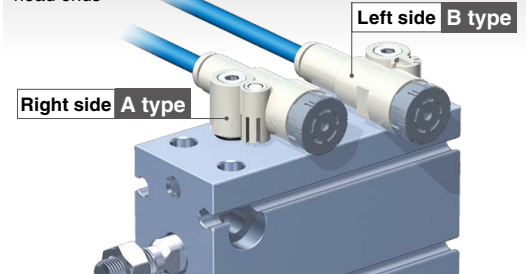

## Easy identification of product type

Metric  
Light gray



Inch  
Orange



**Compact Type** **Push-lock Type**

# Speed Exhaust Controller with One-touch Fitting Elbow Type

# JASV Series



## Model

Model	Port size	Seal method	Applicable tubing O.D.					
			Metric size			Inch size		
			3.2	4	6	1/8"	5/32"	1/4"
JASV-LE□□-M3	M3 x 0.5	Gasket seal	●	●	—	—	—	—
JASV-LE□□-M5	M5 x 0.8		●	●	●	—	—	—
JASV-LE□□-U10	10-32UNF		—	—	—	●	●	—
JASV-LE□□-□01	R* <sup>1</sup>	1/8	—	●	●	—	—	—
JASV-LE□□-□01	NPT* <sup>1</sup>							
JASV-LE□□-□01	G	Face seal	—	●	●	—	—	—

\*1 "Without sealant" type can be selected as a standard option.

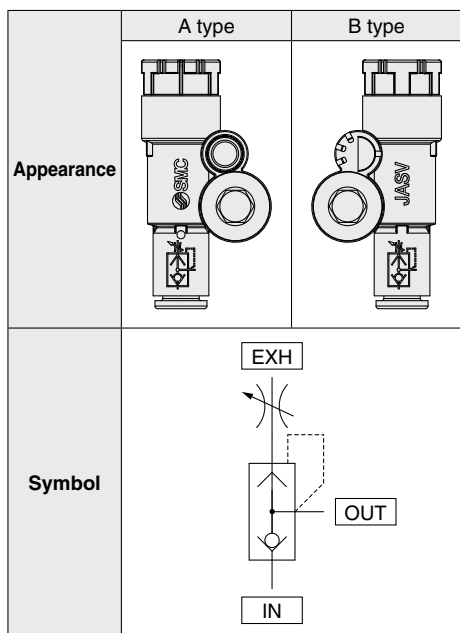

## Specifications

Fluid	Air
Proof pressure	1.05 MPa
Max. operating pressure	0.7 MPa
Min. operating pressure	0.1 MPa
Ambient and fluid temperatures	-5 to 60°C (No freezing)
Applicable tubing material	Nylon, Soft nylon, Polyurethane, FEP, PFA

\* Use caution at the max. operating pressure when using soft nylon or polyurethane tubing. (Refer to the **Web Catalog** or **Best Pneumatics Catalog** for details.)

## Flow Rate and Sonic Conductance

Model		JASV-□-M3	JASV-□-M5	JASV-□-□01□	
Tubing O.D.	Metric size	ø3.2 ø4	ø3.2 ø4 ø6	ø4	ø6
	Inch size	—	ø1/8" ø5/32"	ø5/32"	ø1/4"
C values: Sonic conductance dm <sup>3</sup> /(s·bar)	IN → OUT	0.14	0.3	0.75	0.85
	OUT → EXH	0.17	0.25	0.55	
b values: Critical pressure ratio	IN → OUT	0.4	0.2	0.1	
	OUT → EXH	0.13	0.19	0.2	

\* 10-32UNF has the same specification as M5.

\* C and b values are for controlled flow with the needle fully open and free flow with the needle fully closed.

### ⚠ Caution

Be sure to read this before handling the products.  
Refer to the back cover for safety instructions. For flow control equipment precautions, refer to the "Handling Precautions for SMC Products" and the "Operation Manual" on the SMC website:  
<https://www.smcworld.com>

## How to Order



**JASV-LEA04-M5**  
**JASV-LEA04-01S**

**Type**

L	Elbow
---	-------

**Stud position**

A	Right side
B	Left side

\* Stud position left/right is defined with hexagonal socket visible and knob facing upward.

**Stud position detail**

A: Right side      B: Left side

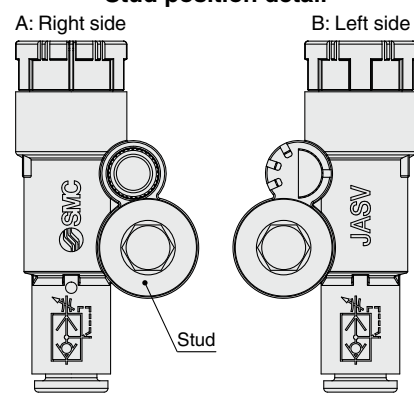

**Port size**

M3	M3 x 0.5
M5	M5 x 0.8
U10	10-32UNF

**Seal method**

Nil	Without sealant
S	With sealant

\* Face seal type is used for the G thread type.  
 Select "Nil/Without sealant."  
 Example) JASV-LEA04-G01

**Port size**

01	1/8
----	-----

**Thread type**

Nil	R
N	NPT
G	G

**Applicable tubing O.D.\*1**

Metric size		Inch size*3	
23	ø3.2*2	01	ø1/8"
04	ø4	03	ø5/32"
06	ø6	07	ø1/4"

\*1 For selecting applicable tubing O.D., refer to the "Model" on page 3.  
 \*2 Use ø1/8" tubing.  
 \*3 Only the metric size is available for the G thread type.



# JASV Series

## Flow Rate Characteristics

**JASV-LE□□-M3** OUT-EXH. Flow rate

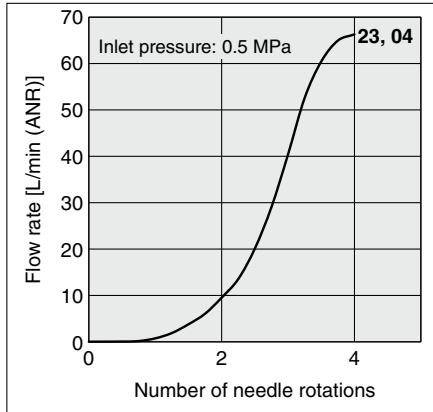

**JASV-LE□□-M5, U10** OUT-EXH. Flow rate

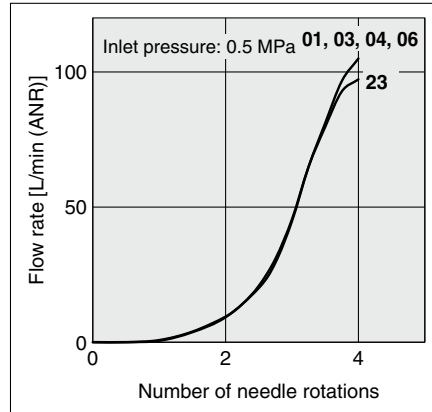

**JASV-LE□□-□01□** OUT-EXH. Flow rate

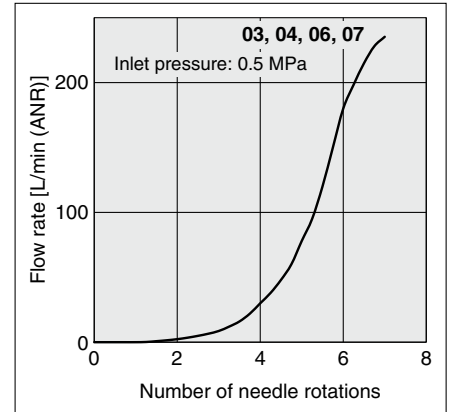

\* The numbers above the flow rate characteristic curves in the charts show the applicable tubing outside diameter as defined by the product number.

## Construction

**Seal method: Gasket seal**  
For M3, M5, 10-32UNF

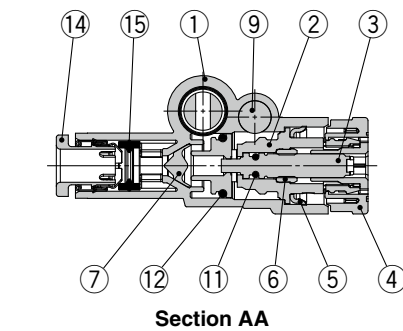
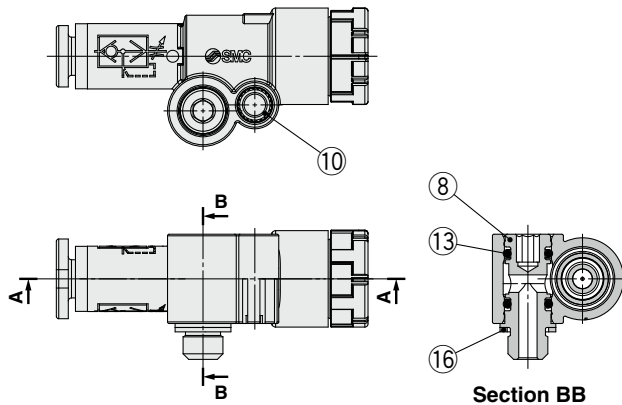

**Seal method: Face seal**  
For G thread

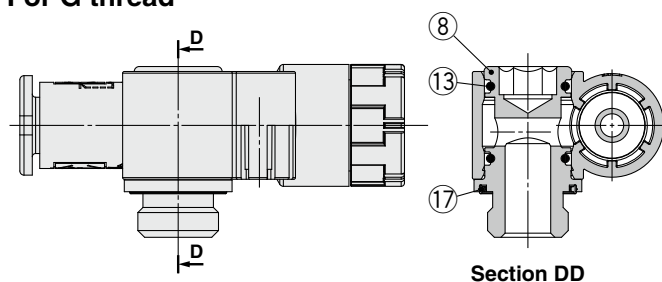

**Seal method: Sealant**  
For R, NPT thread

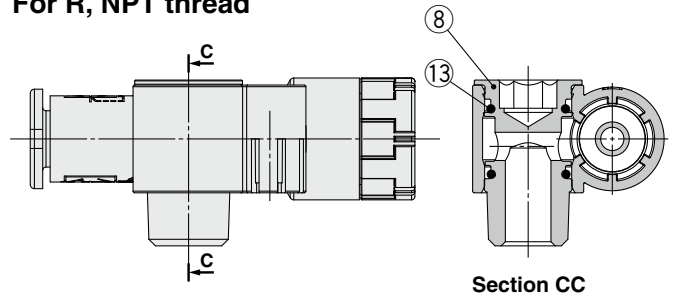

### Component Parts

No.	Description	Material	Note
1	Body A	PBT	
2	Body B	PBT	
3	Needle	PBT	
4	Knob	POM	
5	Stopper	Stainless steel	
6	Needle guide	Brass	Electroless nickel plating
7	Valve	HNBR	
8	Stud	Brass	Electroless nickel plating
9	Silencer	PVA sponge	
10	Cover	Brass	Electroless nickel plating
11	O-ring	NBR	
12	O-ring	NBR	
13	O-ring	NBR	
14	Cassette	—	
15	Seal	NBR	
16	Gasket	NBR/Stainless steel	
17	Seal	NBR	

## Dimensions

Seal method: Gasket seal  
For M3, M5, 10-32UNF

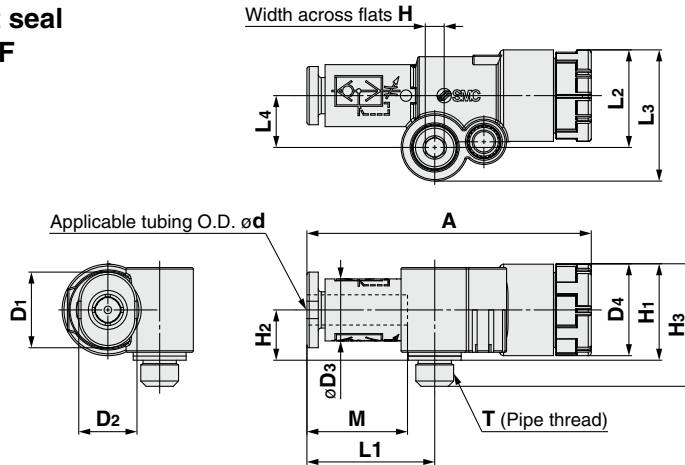

### Metric Size

Model	d	T	H	Release button		D3	D4	A		L1	L2	L3	L4	H1	H2	H3	M	Weight [g]
				D1	D2			Unlocked	Locked									
JASV-LE□23-M3	3.2	M3 x 0.5	2.5	9.5	6.7	7.2	12.1	40.4	39.1	18.4	12.9	17.4	6.9	12.7	6.6	15.2	13.3	6
JASV-LE□04-M3	4			10	7.7	8.2												6
JASV-LE□23-M5	3.2	M5 x 0.8		9.5	6.7	7.2												6
JASV-LE□04-M5	4			10	7.7	8.2												6
JASV-LE□06-M5	6			12	9.7	10.4												6

### Inch Size

Model	d	T	H	Release button		D3	D4	A		L1	L2	L3	L4	H1	H2	H3	M	Weight [g]
				D1	D2			Unlocked	Locked									
JASV-LE□01-U10	1/8	10/32UNF	2.5	9.5	6.7	7.2	12.1	40.4	39.1	18.4	12.9	17.4	6.9	12.7	6.6	16.2	13.3	6
JASV-LE□03-U10	5/32			10	7.7	8.2												6

Seal method: Sealant  
For R, NPT thread

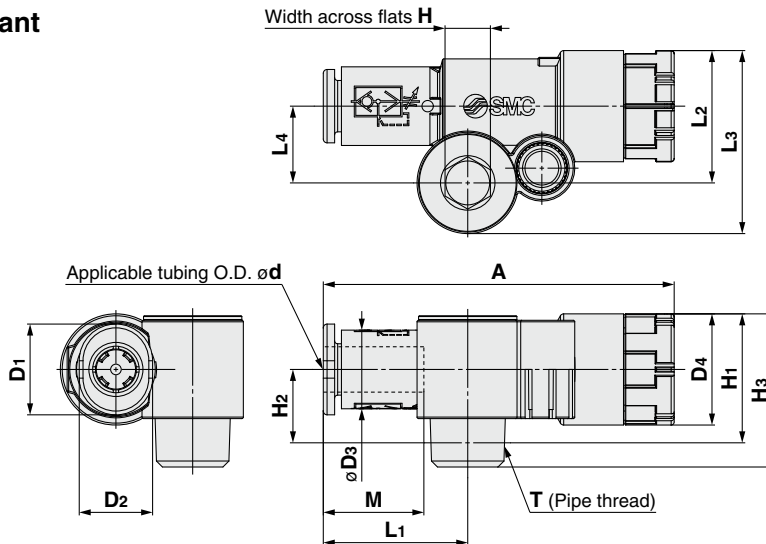

### Metric Size

Model	d	T (R, NPT)	H	Release button		D3	D4	A		L1	L2	L3	L4	H1	H2	H3	M	Weight [g]
				D1	D2			Unlocked	Locked									
JASV-LE□04-01(S)	4	1/8	6	10	7.7	8.2	14.7	48.4	46.6	19.1	17.5	24.2	10.2	17.1	9.7	20.3	13.3	15
JASV-LE□06-01(S)	6			12	9.7	10.4												15

### Inch Size

Model	d	T (R, NPT)	H	Release button		D3	D4	A		L1	L2	L3	L4	H1	H2	H3	M	Weight [g]
				D1	D2			Unlocked	Locked									
JASV-LE□03-N01(S)	5/32	1/8	5.56	10	7.7	8.2	14.7	48.4	46.6	19.1	17.5	24.2	10.2	17.1	9.7	20.3	13.3	15
JASV-LE□07-N01(S)	1/4			10.9	—	11.2												15

# JASV Series

## Dimensions

Seal method: Face seal  
For G thread

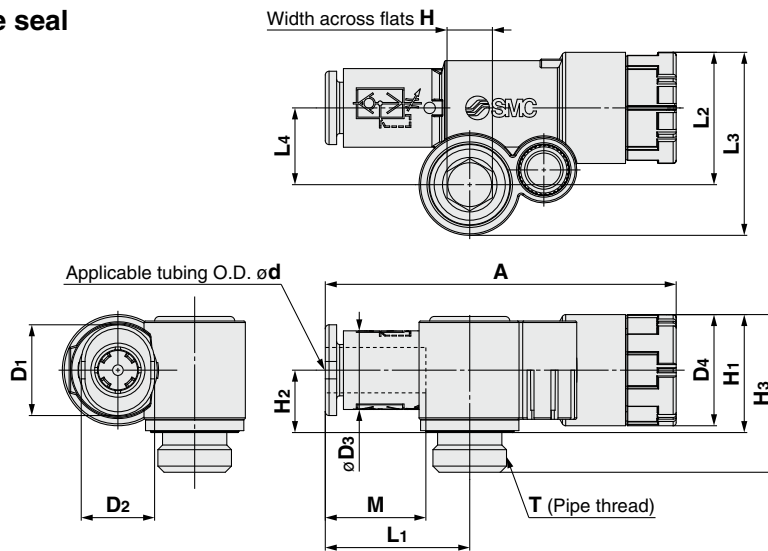

## Metric Size

Model	d	T	H	Release button		D <sub>3</sub>	D <sub>4</sub>	A		L <sub>1</sub>	L <sub>2</sub>	L <sub>3</sub>	L <sub>4</sub>	H <sub>1</sub>	H <sub>2</sub>	H <sub>3</sub>	M	Weight [g]
				D <sub>1</sub>	D <sub>2</sub>			Unlocked	Locked									
JASV-LE□04-G01	4	1/8	6	10	7.7	8.2	14.7	48.4	46.6	19.1	17.5	24.2	10.2	15.6	8.3	20.9	13.3	15
JASV-LE□06-G01	6			12	9.7	10.4		15										





# JASV Series Specific Product Precautions 1

Be sure to read this before handling the products. Refer to the back cover for safety instructions. For flow control equipment precautions, refer to the “Handling Precautions for SMC Products” and the “Operation Manual” on the SMC website: <https://www.smcworld.com>

## Design

### Warning

#### 1. Confirm the specifications.

Do not operate at pressures, temperatures, etc., beyond the range of specifications, as this can cause damage or malfunction. (Refer to the specifications.)

Please contact SMC when using a fluid other than compressed air (including vacuum).

We do not guarantee against any damage if the product is used outside of the specification range.

#### 2. Products mentioned in this catalog are not designed for use as stop valves with zero air leakage.

A certain amount of leakage is allowed in the products' specifications.

Tightening the needle forcibly to achieve zero leakage may result in damage of contact face stopper.

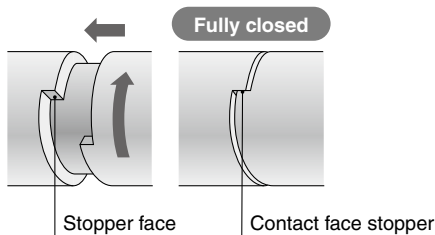

#### 3. Do not disassemble the product or make any modifications, including additional machining.

Doing so may cause human injury and/or an accident.

#### 4. The flow rate characteristics for each product are representative values.

The flow rate characteristics are characteristics of each individual product. Actual values may differ depending on the piping, circuitry, pressure conditions, etc.

There will be no flow rate from the fully closed position until 1 to 1.5 turns due to the product characteristic, but this is not the problem.

#### 5. Sonic conductance (C) and critical pressure ratio (b) values for products are representative values.

#### 6. Check if PTFE can be used in the application.

PTFE powder (Polytetrafluoroethylene resin) is included in the seal material of the male thread type piping taper thread. Confirm that the use of it will not cause any adverse effects on the system.

Please contact SMC if the Material Safety Data Sheet (SDS) is required.

#### 7. Speed exhaust controllers are designed to control the speed of the actuator.

#### 8. The directional control valve should be 3, 4 or 5-port valve with exhaust port(s).

#### 9. Exhaust air from the directional control valve completely.

If the exhaust from the directional control valve is incomplete, a correct exhaust from JASV will not be performed. This causes residual pressure to occur in the system, and could result in personal injury.

## Design

### Caution

#### 1. In the following cases, insufficient exhaust or vibration may cause noise.

- With residual pressure or back pressure on the IN side.
- When the differential pressure between the IN and OUT sides is smaller than the minimum operating pressure.
- When the effective area of the IN side piping and directional control valve (solenoid valve) is smaller than JASV.
- When reduction of the IN side pressure is slower than that of the OUT side pressure during JASV operation.
- The IN side piping (tubing) is bent or squashed.

#### 2. Do not lubricate.

The necessary amount of lubricant is applied during assembly, so additional lubrication is not required during operation.

If lubrication is added, operational failure may occur due to running out of the initial lubricant or clogging of the sound absorbing material.

## Mounting

### Warning

#### 1. Operation manual

Install the product and operate it only after reading the operation manual carefully and understanding its contents. Also, keep the manual where it can be referred to as necessary.

#### 2. Ensure sufficient space for maintenance activities.

When installing the products, allow access for maintenance and inspection.

#### 3. Tighten threads with the proper tightening torque.

When installing the products, follow the listed torque specifications.

#### 4. Screw the R screw into the Rc thread, the NPT screw into the NPT thread and the G screw into the G thread.

#### 5. After pushing the knob down to lock, confirm that it is locked.

When the orange mark is visible, the speed controller is unlocked. Confirm that the knob is locked by pushing the knob in after adjusting the cylinder speed. When the speed controller is unlocked, the set flow may change.

If the knob is pulled with force while the speed controller is unlocked, it may result in breakage. When it is unlocked, do not pull the knob out with force.





# JASV Series

## Specific Product Precautions 2

Be sure to read this before handling the products. Refer to the back cover for safety instructions. For flow control equipment precautions, refer to the “Handling Precautions for SMC Products” and the “Operation Manual” on the SMC website: <https://www.smcworld.com>

### Mounting

#### Warning

##### 6. Check the degree of rotation of the needle valve.

As the needle valve has a stopper mechanism for max. open, it is not possible to rotate beyond the given limit. Forceful rotation of the needle beyond this point will cause damage, so check the table below for the number of rotations.

Connection thread size	Number of needle rotations (reference)
M3, M5, 10-32UNF	4
1/8	7

##### 7. Do not use tools, such as pliers, to rotate the knob.

This can cause the idle rotation of the knob or damage.

##### 8. Mount after confirming the piping direction.

Connect the IN side to the directional control valve and OUT side to the actuator. Mounting backward is dangerous because the speed adjustment needle will not work, and the actuator may lurch suddenly.

##### 9. Adjust the needle by opening the needle slowly after having closed it completely.

Loose needle valves may cause unexpected sudden actuator extension.

When a needle valve is turned clockwise, it is closed and cylinder speed decreases. When a needle valve is turned counterclockwise, it is open and cylinder speed increases. Unlock the knob before adjusting the needle valve with a flat blade screwdriver. Excessive torque may break the needle valve, so check the table below for the proper adjusting torque.

Connection thread size	Proper adjusting torque [N·m]	Recommended screwdriver
M3, M5 10-32UNF	0.015	Nominal thickness $a = 0.4$ Nominal width $b = 2.5$ ( $t1 = 0.2$ )
1/8	0.03	Nominal thickness $a = 0.5$ Nominal width $b = 3$ ( $t1 = 0.3$ )

Screwdriver tip end shape

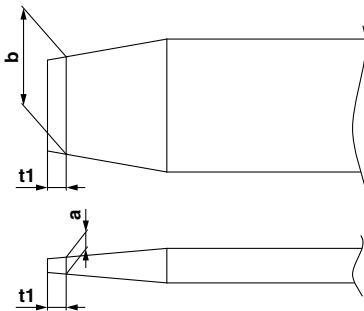

##### 10. Do not apply excessive force or shock to the body or fittings with an impact tool.

This can cause damage or air leakage.

##### 11. Refer to the Fittings and Tubing Precautions for handling One-touch fittings.

##### 12. Insert the hexagon wrench into the end of the hexagonal hole of the stud when removing and mounting the speed controller.

Do not apply torque at other points, as the product may be damaged. Rotate body A manually for positioning after installation.

Refer to the applicable dimension of the hexagon wrench.

Connection thread size	Hexagon wrench (Nominal width across flats)	
	Metric size	Inch size
M3, M5	2.5	—
10-32UNF	—	3/32"
R1/8, G1/8	6	—
NPT1/8	—	7/32"

##### 13. Do not use this product in the operating condition where moment loads will be constantly applied to Body A.

Body A and the fitting section may be damaged.



##### 14. This product has a stopper for the fully close needle position.

Excessive torque may break the stopper, so check the table below for the maximum allowable torque of the knob.

Connection thread size	Max. allowable torque [N·m]
M3, M5, 10-32UNF	0.05
01	0.07



# JASV Series Specific Product Precautions 3

Be sure to read this before handling the products. Refer to the back cover for safety instructions. For flow control equipment precautions, refer to the “Handling Precautions for SMC Products” and the “Operation Manual” on the SMC website: <https://www.smcworld.com>

## Mounting

### ⚠ Caution

#### 1. M3, M5 and 10-32UNF

##### 1) Tightening method

###### M3

First, tighten it by hand, then give it an additional 1/6 turn to 1/4 turn with a hexagon wrench.

Use the tightening torque shown in the table below as a guide.

Connection thread size	Proper tightening torque [N·m]
M3	0.4 to 0.5

###### M5 and 10-32UNF

First, tighten it by hand, then give it an additional 1/6 turn to 1/4 turn with a hexagon wrench.

Use the tightening torque shown in the table below as a guide.

Connection thread size	Proper tightening torque [N·m]
M5, 10-32UNF	1 to 1.5

\* Excessive tightening may damage the thread portion or deform the gasket and cause air leakage. If the screw is too shallowly screwed in, it may come loose or air may leak.

##### 2) Female thread chamfer size

In compliance with ISO16030 Standards (air pressure fluid dynamics – connection – ports and stud ends), the chamfered thread sizes shown below are recommended.

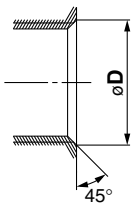

Connection thread size	Chamfer dimension øD (Recommended value)
M3	3.1 to 3.4
M5	5.1 to 5.4
10-32UNF	5.0 to 5.3

## 2. R, NPT and G Thread

##### 1) Tightening method

When tightening the stud, insert an appropriate hexagon wrench to the hexagonal hole after tightening it by hand.

Use the tightening torque shown in the table below as a guide.

Connection thread size	Proper tightening torque [N·m]
1/8	3 to 5

##### 2) Female thread chamfer size

By chamfering as shown in the following table, machining of threads is easier and effective for burr prevention.

Connection thread size	Chamfer dimension øD (Recommended value)		
	Rc	NPT	G Face seal
1/8	10.2 to 10.4	10.5 to 10.7	9.8 to 10.2

\* G thread (face seal) complies with ISO 16030-2001.

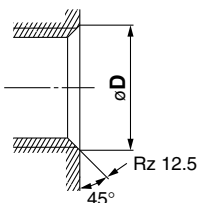

## Piping Threads with Sealant

### ⚠ Caution

1. If the fitting is tightened with excessive torque, a large amount of sealant will seep out. Remove the excess sealant.
2. Insufficient tightening may loosen the threads or cause air leakage.
3. For reuse
  - 1) Normally, fittings with a sealant can be reused up to 2 to 3 times.
  - 2) To prevent air leakage through the sealant, remove any loose sealant stuck to the fitting by blowing air over the threaded portion.
  - 3) If the sealant no longer provides effective sealing, wind sealant tape over the sealant before reusing. Do not use any form other than the tape type of sealant.
4. Once the fitting has been tightened, backing it out to its original position often causes the sealant to become defective. Air leakage will occur.

## Piping

### ⚠ Caution

1. Refer to the Fittings and Tubing Precautions for handling One-touch fittings.

##### 2. Preparation before piping

Before piping is connected, it should be thoroughly blown out with air (flushing) or washed to remove chips, cutting oil, and other debris from inside the pipe.

## Piping Threads with Sealant

##### 1. Winding of sealant tape

When screwing piping or fittings into ports, ensure that chips from the pipe threads or sealing material do not enter the piping. Also, if sealant tape is used, leave 1 thread ridge exposed at the end of the threads.

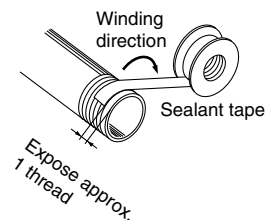

## Safety Instructions

These safety instructions are intended to prevent hazardous situations and/or equipment damage. These instructions indicate the level of potential hazard with the labels of “**Caution**,” “**Warning**” or “**Danger**.” They are all important notes for safety and must be followed in addition to International Standards (ISO/IEC)\*1), and other safety regulations.

 **Caution:** **Caution** indicates a hazard with a low level of risk which, if not avoided, could result in minor or moderate injury.

 **Warning:** **Warning** indicates a hazard with a medium level of risk which, if not avoided, could result in death or serious injury.

 **Danger:** **Danger** indicates a hazard with a high level of risk which, if not avoided, will result in death or serious injury.

\*1) ISO 4414: Pneumatic fluid power – General rules relating to systems.  
ISO 4413: Hydraulic fluid power – General rules relating to systems.  
IEC 60204-1: Safety of machinery – Electrical equipment of machines.  
(Part 1: General requirements)  
ISO 10218-1: Manipulating industrial robots – Safety.  
etc.

### Warning

#### 1. The compatibility of the product is the responsibility of the person who designs the equipment or decides its specifications.

Since the product specified here is used under various operating conditions, its compatibility with specific equipment must be decided by the person who designs the equipment or decides its specifications based on necessary analysis and test results. The expected performance and safety assurance of the equipment will be the responsibility of the person who has determined its compatibility with the product. This person should also continuously review all specifications of the product referring to its latest catalog information, with a view to giving due consideration to any possibility of equipment failure when configuring the equipment.

#### 2. Only personnel with appropriate training should operate machinery and equipment.

The product specified here may become unsafe if handled incorrectly. The assembly, operation and maintenance of machines or equipment including our products must be performed by an operator who is appropriately trained and experienced.

#### 3. Do not service or attempt to remove product and machinery/equipment until safety is confirmed.

1. The inspection and maintenance of machinery/equipment should only be performed after measures to prevent falling or runaway of the driven objects have been confirmed.
2. When the product is to be removed, confirm that the safety measures as mentioned above are implemented and the power from any appropriate source is cut, and read and understand the specific product precautions of all relevant products carefully.
3. Before machinery/equipment is restarted, take measures to prevent unexpected operation and malfunction.

#### 4. Contact SMC beforehand and take special consideration of safety measures if the product is to be used in any of the following conditions.

1. Conditions and environments outside of the given specifications, or use outdoors or in a place exposed to direct sunlight.
2. Installation on equipment in conjunction with atomic energy, railways, air navigation, space, shipping, vehicles, military, medical treatment, combustion and recreation, or equipment in contact with food and beverages, emergency stop circuits, clutch and brake circuits in press applications, safety equipment or other applications unsuitable for the standard specifications described in the product catalog.
3. An application which could have negative effects on people, property, or animals requiring special safety analysis.
4. Use in an interlock circuit, which requires the provision of double interlock for possible failure by using a mechanical protective function, and periodical checks to confirm proper operation.

### Caution

#### 1. The product is provided for use in manufacturing industries.

The product herein described is basically provided for peaceful use in manufacturing industries.  
If considering using the product in other industries, consult SMC beforehand and exchange specifications or a contract if necessary.  
If anything is unclear, contact your nearest sales branch.

### Limited warranty and Disclaimer/ Compliance Requirements

The product used is subject to the following “Limited warranty and Disclaimer” and “Compliance Requirements”.

Read and accept them before using the product.

#### Limited warranty and Disclaimer

1. The warranty period of the product is 1 year in service or 1.5 years after the product is delivered, whichever is first.\*2)  
Also, the product may have specified durability, running distance or replacement parts. Please consult your nearest sales branch.
2. For any failure or damage reported within the warranty period which is clearly our responsibility, a replacement product or necessary parts will be provided.  
This limited warranty applies only to our product independently, and not to any other damage incurred due to the failure of the product.
3. Prior to using SMC products, please read and understand the warranty terms and disclaimers noted in the specified catalog for the particular products.

##### \*2) Vacuum pads are excluded from this 1 year warranty.

A vacuum pad is a consumable part, so it is warranted for a year after it is delivered.  
Also, even within the warranty period, the wear of a product due to the use of the vacuum pad or failure due to the deterioration of rubber material are not covered by the limited warranty.

#### Compliance Requirements

1. The use of SMC products with production equipment for the manufacture of weapons of mass destruction (WMD) or any other weapon is strictly prohibited.
2. The exports of SMC products or technology from one country to another are governed by the relevant security laws and regulations of the countries involved in the transaction. Prior to the shipment of a SMC product to another country, assure that all local rules governing that export are known and followed.

### Caution

#### SMC products are not intended for use as instruments for legal metrology.

Measurement instruments that SMC manufactures or sells have not been qualified by type approval tests relevant to the metrology (measurement) laws of each country. Therefore, SMC products cannot be used for business or certification ordained by the metrology (measurement) laws of each country.

## Safety Instructions

Be sure to read the “Handling Precautions for SMC Products” (M-E03-3) and “Operation Manual” before use.