

Grippers for Collaborative Robots

Compliant with the MELFA ASSISTA series



Mitsubishi Electric Corporation

collaborative robot



More information
can be viewed here.

Vacuum Gripper
ZXP7□-X1□-ASSISTA



Magnet Gripper
MHM-X7400A-ASSISTA



Air Gripper
JMHZ2-X7400B-ASSISTA



CAT.ES160-3A

Grippers for Collaborative Robots

Mitsubishi Electric Corporation

MELFA ASSISTA compliant products

For Adsorption

Vacuum Gripper p. 4 **ZXP7□-X1□-ASSISTA**

- Operate by simply connecting 1 compressed air supply tube and an electrical wiring M12 connector.
- Integrated vacuum ejector, air supply valve, pressure switch, and cups
- A wide variety of cup variations are available to support a wide range of workpieces.
- Standards: Conforming to ISO9409-1-31.5-4-M5

Max. work load [kg]	7
Max. vacuum pressure [kPa]	-84
Suction flow rate [L/min (ANR)]	17
Weight [g]	793*1

*1 Without cup mounting flange



For Adsorption

Magnet Gripper p. 9 **MHM-X7400A-ASSISTA**

- Attracts and holds heavy objects with a magnet
- Supports workpieces with holes and uneven surfaces
- Holding force: Max. 200 N (ø25, Workpiece thickness 6 mm)
- Continues to hold workpieces even when the air is shut off
- Operate by simply connecting 1 compressed air supply tube and an electrical wiring M12 connector.
- Integrated solenoid valve, auto switch, and piston speed adjustment mechanism
- Standards: Conforming to ISO9409-1-31.5-4-M5

Holding force [N]	Workpiece thickness: 2 mm	160
	Workpiece thickness: 6 mm	200
Weight [g]		780



For Gripping

Air Gripper p. 12 **JMHZ2-X7400B-ASSISTA**

- Compact, lightweight product with high gripping force due to air operation
- With high-precision linear guide: Repeatability: ± 0.01 mm
- Operate by simply connecting 1 compressed air supply tube and an electrical wiring M12 connector.
- Integrated solenoid valve, speed adjustment mechanism, and auto switch
- Standards: Conforming to ISO9409-1-31.5-4-M5

Gripping force Effective value per finger [N]	External	32.7
	Internal	43.5
Opening/Closing stroke (Both sides) [mm]		10
Weight [g]		680



CONTENTS

Grippers for Collaborative Robots

Mitsubishi Electric Corporation
MELFA ASSISTA compliant products



For Adsorption

Vacuum Gripper
ZXP7□-X1□-ASSISTA

p. 4

Features	p. 4
Specifications	p. 4
Cup Variations	p. 5
How to Order	p. 6
Model Selection	p. 7
Dimensions	p. 7
Specific Product Precautions	p. 8



For Adsorption

Magnet Gripper
MHM-X7400A-ASSISTA

p. 9

Features	p. 9
Component Parts	p. 9
How to Order	p. 9
Specifications	p. 9
Characteristics	p. 10
Dimensions	p. 10
Specific Product Precautions	p. 11



For Gripping

Air Gripper
JMHZ2-X7400B-ASSISTA

p. 12

Features	p. 12
Component Parts	p. 12
How to Order	p. 12
Specifications	p. 12
Characteristics	p. 13
Dimensions	p. 13
Specific Product Precautions	p. 14

Vacuum Gripper for Collaborative Robots

Mitsubishi Electric Corporation collaborative robot

MELFA ASSISTA compliant



Operate by simply connecting 1 compressed air supply tube and an electrical wiring M12 connector.

- Integrated vacuum ejector, air supply valve, pressure switch, and cups
- Features a rounded appearance without corners
- A wide variety of cup variations are available to support a wide range of workpieces.

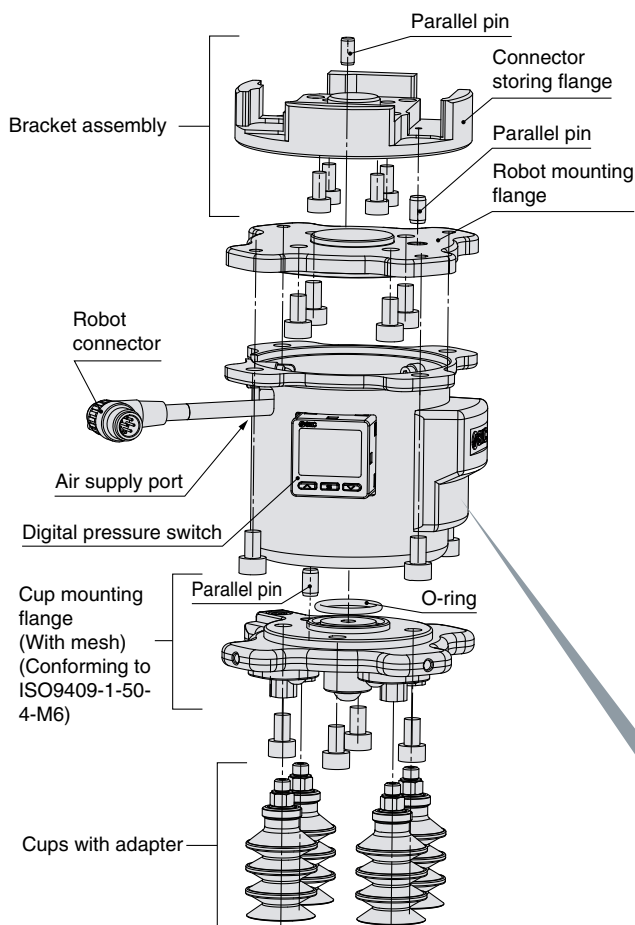

Specifications

Common	Applicable fluid	Air
	Operating temperature range [°C]	5 to 50
	Weight [g] ^{*3}	1018 (793)
	Max. work load [kg] ^{*4}	7
	Air pressure supply (P) port	One-touch fitting (ø6)
	Power supply voltage [V]	24 VDC ±10%
Vacuum ejector	Connector type	M12 8-pin connector (Plug)
	Max. vacuum pressure [kPa] ^{*5}	-84
	Suction flow rate [L/min (ANR)] ^{*5}	17
	Air consumption [L/min (ANR)] ^{*5}	57
	Supply pressure range [MPa]	0.3 to 0.55
	Standard supply pressure [MPa] ^{*6}	0.5
Pressure switch	Rated pressure range [kPa]	0 to -101
	Display accuracy	±2% F.S. ±1 digit (Ambient temperature of 25 ±3°C)
	Repeatability	±0.2% F.S. ±1 digit
	Temperature characteristics	±2% F.S. (25°C conversion)

■ Included parts: Robot mounting flange, Parallel pin, Mounting bolt, Connector storing flange, Cups with adapter^{*1}, Bolt for plug^{*2}, Coil tube for piping (ø6), Piping fittings (3 types)

- *1 Included only with cups
- *2 Included only for the ZXP7A
- *3 The weight in brackets refers to the weight of the product without a cup mounting flange. Add the weight of the suction cups with adapter for the weight with cups. (Refer to the "Suction Cup Part Numbers and Weight" on page 6.)
- *4 May be restricted depending on the cup diameter, mounting orientation, or workpiece. Please use within the max. work load. Suction and transfer exceeding the max. work load may result in reduced vacuum pressure due to air leakage.
- *5 Values are at the standard supply pressure and based on SMC's measurement standards. They depend on atmospheric pressure (weather, altitude, etc.) and the measurement method.
- *6 This value indicates the pressure right before the air pressure supply (P) port when vacuum is generated. The pressure right before the P port of the vacuum gripper when vacuum is generated may fall below 0.5 MPa due to the air supply capacity, piping size, and the amount of air being consumed by other devices being operated simultaneously.

Details of internal parts

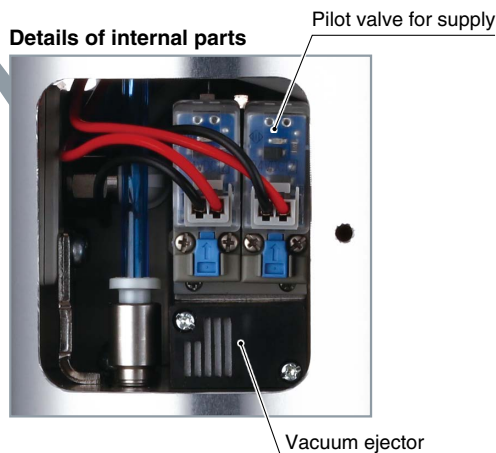

Vacuum Gripper

Magnet Gripper

Air Gripper

Cup Variations

The number of cups can be changed. (Refer to the operation manual for details on changing the quantity.)



1 cup

2 cups

4 cups

The cup type can be changed. (For details on selectable cups, refer to "How to Order.")



Flat (ø8), Silicone rubber

Bellows (ø20), NBR

Thin flat (ø16), NBR

Flat (ø32), Silicone rubber

Flat (ø32), Urethane rubber



ø32, 2.5-stage, Silicone rubber

ø25, 5.5-stage, Silicone rubber

ø25, 5.5-stage, Silicone rubber
With vacuum saving valve



Vacuum saving valve
ZP2V Series
(To be ordered separately)
Applicable part no.: ZP2V-B6-05

* The silicone material is compliant with the FDA (U.S. Food and Drug Administration) regulation 21CFR§177.

The cup pitch can be changed.

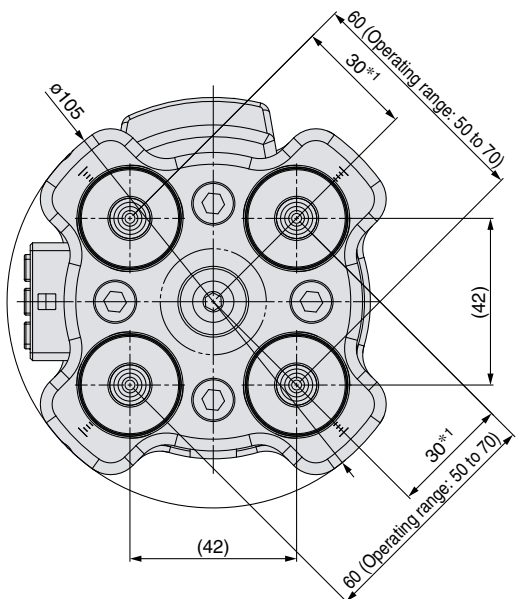

*1 Operating range: 25 to 35 (When a cup is mounted in the center)
As interference between cups may occur depending on the cup diameter, select the cup diameter according to the pitch to be used.



Combination part no. **ZXP 7** - - **X1** - **ASSISTA**

1 Body size

Symbol	Size
7	75 mm

2 Cup mounting flange shape

Symbol	Flange shape
A	With flange (42 mm x 42 mm)
N	Without flange

With flange Without flange

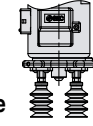

* Customers selecting the product without a cup mounting flange will be required to produce a flange that matches the mounting dimensions on their own.

5 Cup form

Symbol	Cup form
U	Flat
C	Flat with rib
B	Bellows
UT	Thin flat
J	Multistage bellows
JT2	2.5-stage bellows
JT5	5.5-stage bellows
Nil	Without cup

6 Cup material

Symbol	Material
N	NBR
S	Silicone rubber (White)*2
U	Urethane rubber
F	FKM
SF	Silicone rubber (Blue)*2
Nil	Without cup

*2 The silicone material is compliant with the FDA (U.S. Food and Drug Administration) regulation 21CFR§177.

3 Cup series

Symbol	Cup series
ZP	Basic
ZP3P	Bellows type for film packaging workpieces
Nil	Without cup

4 Cup diameter

Symbol	Cup diameter	Symbol	Cup diameter
08	ø8	25	ø25
10	ø10	B25	ø25
13	ø13	B30	ø30
16	ø16	32	ø32
20	ø20	Nil	Without cup

7 Attachment*3

Symbol	Attachment
Nil	With (guide) attachment
M	With mesh attachment

*3 Only applicable to the cup form "JT□." Note that "M" applies only to cup form: JT2.

8 Pressure switch output specifications/Unit

Symbol	Output/Unit
Nil	NPN/With unit switching function*4
A	NPN/NI unit only*5
B	NPN/With unit switching function (Initial value psi)*4
C	PNP/With unit switching function*4
D	PNP/NI unit only*5
E	PNP/With unit switching function (Initial value psi)*4

*4 Under the New Measurement Act, switches with the unit switching function are not permitted for use in Japan.

*5 Fixed unit: kPa, MPa

*1

Suction Cup Part Numbers and Weight

Part No. **ZXP7(A,N)** - - **X1** - **ASSISTA**

Applicable cups

3 Cup series	4 Cup diameter	5 Cup form	6 Cup material	7 Attachment
ZP	08	U	□	
ZP	08	B	□	
ZP	10	UT	□	
ZP	13	UT	□	
ZP	16	UT	□	
ZP	10	U	□	
ZP	13	U	□	
ZP	16	U	□	
ZP	20	U	□	
ZP	25	U	□	
ZP	32	U	□	
ZP	10	C	□	
ZP	13	C	□	
ZP	16	C	□	
ZP	20	C	□	
ZP	25	C	□	
ZP	32	C	□	
ZP	10	B	□	
ZP	13	B	□	
ZP	16	B	□	
ZP	20	B	□	
ZP	25	B	□	
ZP	32	B	□	
ZP	20	UT	□	
ZP	16	J	□	
ZP	B25	J	□	
ZP	B30	J	□	
ZP3P	20	JT2	SF	
ZP3P	20	JT2	SF	M
ZP3P	32	JT2	SF	
ZP3P	32	JT2	SF	M
ZP3P	20	JT5	SF	
ZP3P	25	JT5	SF	
ZP3P	32	JT5	SF	

Cup part numbers

Part no.	Cup with adapter				Adapter unit Vacuum inlet: (Male thread M6 x 1)	Cup unit	
	Weight by cup material (g/cup)						
	N (NBR)	S/SF (Silicone)	U (Urethane)	F (FKM)			
ZPT08U□-A6	4	4	4	4	ZPT1-A6	ZP08U□	
ZPT08B□-A6	4	4	4	4		ZP08B□	
ZPT10UT□-A6	4	4	4	4		ZP10UT□	
ZPT13UT□-A6	4	4	4	4		ZP13UT□	
ZPT16UT□-A6	4	4	4	4		ZP16UT□	
ZPG10U□-7A-X2	7	7	7	7		ZP10U□	
ZPG13U□-7A-X2	7	7	7	8	ZP13U□		
ZPG16U□-7A-X2	7	7	7	8	ZP16U□		
ZPG20U□-7A-X2	9	10	10	10	ZP20U□		
ZPG25U□-7A-X2	10	10	10	11	ZP25U□		
ZPG32U□-7A-X2	10	11	11	12	ZP32U□		
ZPG10C□-7A-X2	7	7	7	7	ZPT2-7A-X2	ZP10C□	
ZPG13C□-7A-X2	7	7	7	7		ZP13C□	
ZPG16C□-7A-X2	7	7	7	8		ZP16C□	
ZPG20C□-7A-X2	9	10	10	11		ZP20C□	
ZPG25C□-7A-X2	10	10	10	11		ZP25C□	
ZPG32C□-7A-X2	10	11	11	12		ZP32C□	
ZPG10B□-7A-X2	7	7	7	8	ZPT3-7A-X2	ZP10B□	
ZPG13B□-7A-X2	7	8	8	8		ZP13B□	
ZPG16B□-7A-X2	8	8	8	9		ZP16B□	
ZPG20B□-7A-X2	11	11	11	13		ZP20B□	
ZPG25B□-7A-X2	11	12	12	14		ZP25B□	
ZPG32B□-7A-X2	14	15	15	18		ZP32B□	
ZPG20UT□-7A-X2	4	4	4	4	ZPT2-20UT□	ZP2-20UT□	
ZPG16J□-7A-X2	8	8	8	9		ZP2-16J□	
ZPGB25J□-7A-X2	14	15	15	18		ZP2-B25J□	
ZPGB30J□-7A-X2	18	19	19	25		ZP2-B30J□	
ZP3PG20JT2SF-7A-X2	—	21	—	—		ZP3PA-T1JT-7A-X2	ZP3P-20JT2SF-W
ZP3PG20JT2SF-M-7A-X2	—	21	—	—			ZP3P-20JT2SF-WM
ZP3PG32JT2SF-7A-X2	—	48	—	—	ZP3PA-T2JT-7A-X2	ZP3P-32JT2SF-W	
ZP3PG32JT2SF-M-7A-X2	—	48	—	—		ZP3P-32JT2SF-WM	
ZP3PG20JT5SF-7A-X2	—	23	—	—	ZP3PA-T1JT-7A-X2	ZP3P-20JT5SF-WG	
ZP3PG25JT5SF-7A-X2	—	25	—	—		ZP3P-25JT5SF-WG	
ZP3PG32JT5SF-7A-X2	—	54	—	—		ZP3PA-T2JT-7A-X2	ZP3P-32JT5SF-WG

* Refer to the **Web Catalog** for details on suction cups.

Input the material symbol ("N," "S," "U," or "F") into the □ in the part number.

Model Selection

Exhaust Characteristics*1

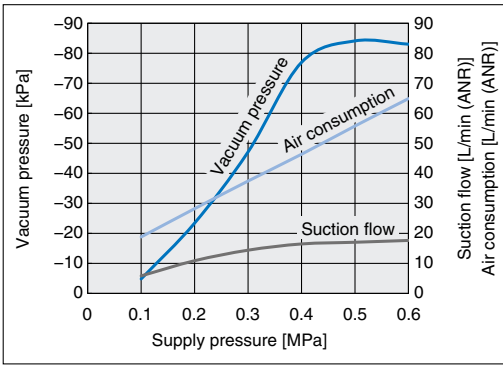

Flow Rate Characteristics

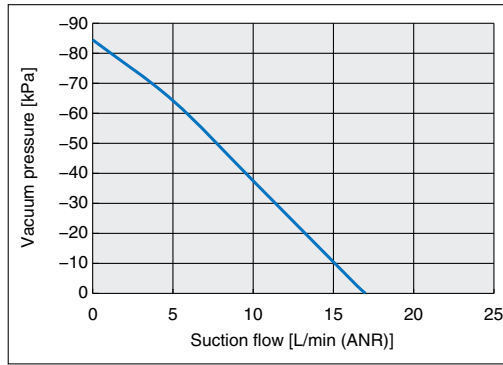

*1 The exhaust characteristics are different when the vacuum-saving valve (ZP2V-B6-05) is mounted.
For details, refer to "8.3 Suction cup precautions" in the operation manual.

Dimensions

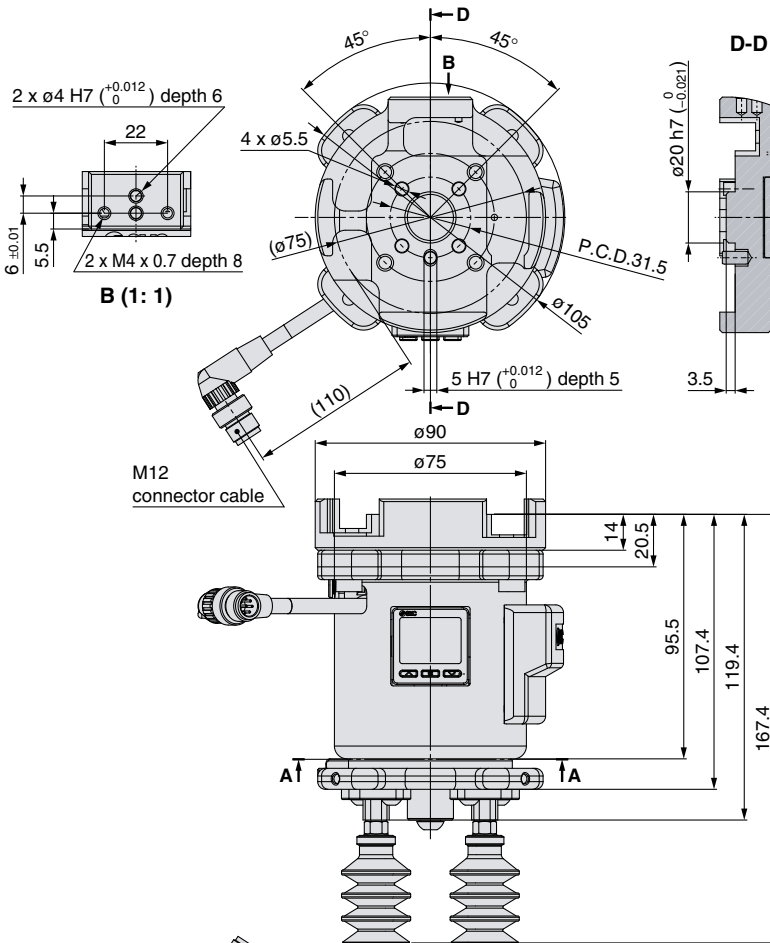

Circuit diagram

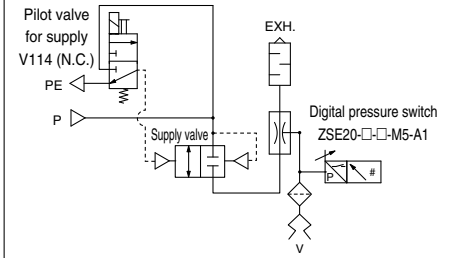

Cup mounting flange

Replacement part number: ZXP7-PFL1-A-X1
(Refer to the figure below for items. Quantities are shown in the parentheses.)

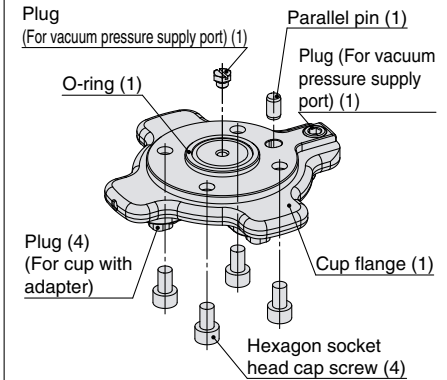

Without cup mounting flange

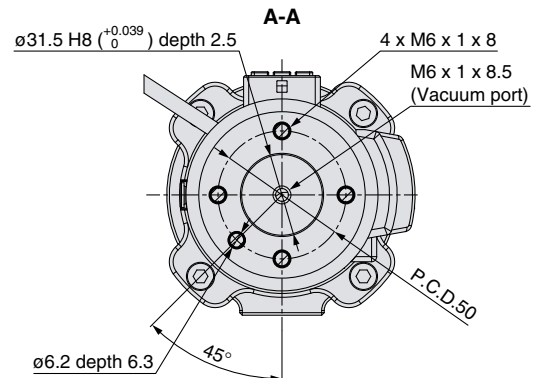

*1 Operating range: 25 to 35
(When a cup is mounted in the center)
As interference between cups may occur depending on the cup diameter, select the cup diameter according to the pitch to be used.

* The dimensions and mounting method described in this drawing (example) are for the following part number: ZXP7A-ZPB25JS-X1-ASSISTA

* The vacuum port doesn't come with mesh.



ZXP7□-X1□-ASSISTA

Specific Product Precautions

Be sure to read this before handling the products. For safety instructions and vacuum equipment precautions, refer to the “Handling Precautions for SMC Products” and the “Operation Manual” on the SMC website: <https://www.smcworld.com>

Handling

Caution

1. Strictly observe the precautions on vacuum equipment and safety when using the product. Additionally, select a cup size and material suitable to both the workpiece to be adsorbed and the atmosphere. Take safety measures so that any accident, such as the dropping of a workpiece, does not occur during adsorption transfer. For details, refer to the Web Catalog.
2. Use the product within the specification range. Use exceeding the compressed air pressure or voltage may result in serious damage due to reduced product performance.
3. Exhaust air is released from the opening in the product. Therefore, this exhaust air opening must not be blocked or restricted.

Mounting

Caution

1. For details on the mounting method, refer to the Operation Manual.
2. Tighten to the specified tightening torque. If the tightening torque is exceeded, the body and the mounting screws may break. However, insufficient torque may cause displacement of the body and loosening of the mounting screws.
3. Do not drop, strike, or apply excessive impact to this product.
Doing so may result in damage to the internal parts of the body, solenoid valve, or pressure switch. In some cases, this damage may result in a malfunction.
4. Hold the body when handling the product. Do not pull excessively on the M12 connector cable or pinch the cable when lifting the body. Failure to do so may result in damage to the solenoid valve or pressure switch. In some cases, this damage may result in a failure or malfunction.
5. The bolts may loosen due to the operating conditions and environment. Be sure to conduct maintenance such as tightening the bolts periodically.

Wiring

Caution

1. Avoid repeatedly bending or stretching the M12 connector cable as well as applying force to it.
2. Do not wire while energizing the product. Doing so may result in damage to the internal parts of the solenoid valve or pressure switch. In some cases, this damage may result in a malfunction.
3. Do not disassemble the M12 connector cable or make any modifications, including additional machining. Doing so may cause human injury and/or an accident.

Piping

Caution

1. **Flushing of the inside of the pipes**
Before piping is connected, it should be thoroughly blown out with air (flushing) or washed to remove chips, cutting oil, and other debris from inside the pipe.
2. **Tube attachment**
 - Take a tube having no flaws on its periphery and cut it off at a right angle. When cutting the tube, use tube cutters TK-1, 2, 3, 5, or 6. Do not use pliers, nippers, scissors, etc. If cutting is done with tools other than tube cutters, the tube may be cut diagonally or become flattened, etc., making a secure installation impossible, and causing problems such as the tube pulling out after installation or air leakage. Allow some extra length in the tube.
 - Grasp the tube and push it in slowly, inserting it securely all the way into the fitting.
 - After inserting the tube, pull on it lightly to confirm that it will not come out. If it is not installed securely all the way into the fitting, this can cause problems such as air leakage or the tube pulling out.
3. **Tube detachment**
 - Push in the release button sufficiently, pushing its collar equally around the circumference.
 - Pull out the tube while holding down the release button so that it does not come out. If the release button is not pressed down sufficiently, there will be increased bite on the tube and it will become more difficult to pull it out.
 - When the removed tube is to be used again, cut off the portion which has been chewed before reusing it. If the chewed portion of the tube is used as is, this can cause trouble such as air leakage or difficulty in removing the tube.
4. **Other Tube Brands**
When using other than SMC brand tube, confirm that the following specifications are satisfied with respect to the tube outside diameter tolerance.

· Nylon tube	within ± 0.1 mm
· Soft nylon tube	within ± 0.1 mm
· Polyurethane tube	within ± 0.15 mm, within -0.2 mm

 Do not use tube which do not meet these outside diameter tolerances. It may not be possible to connect them, or they may cause other trouble, such as air leakage or the tube pulling out after connection.
5. **Piping**
 - Do not apply unnecessary forces, such as twisting, pulling, moment loads, vibration, impact, etc., on fittings or tubing. This will cause damage to fittings and will crush, burst, or release tubing.
 - Do not lift the product by the piping after the tube is connected. Doing so may result in damage to the One-touch tube fitting. For details, refer to the “Handling Precautions for SMC Products” on the SMC website: <https://www.smcworld.com>

Magnet Gripper for Collaborative Robots

Mitsubishi Electric Corporation

MELFA ASSISTA compliant



- Attracts and holds heavy objects with a magnet
- Supports workpieces with holes and uneven surfaces
- Compact with high holding force
 - | Holding force: Max. **200 N** ($\varnothing 25$, Workpiece thickness 6 mm)
- Continues to hold workpieces even when the air is shut off
- Operate by simply connecting 1 compressed air supply tube and an electrical wiring M12 connector.
- Integrated solenoid valve, auto switch, and piston speed adjustment mechanism
- Component Parts

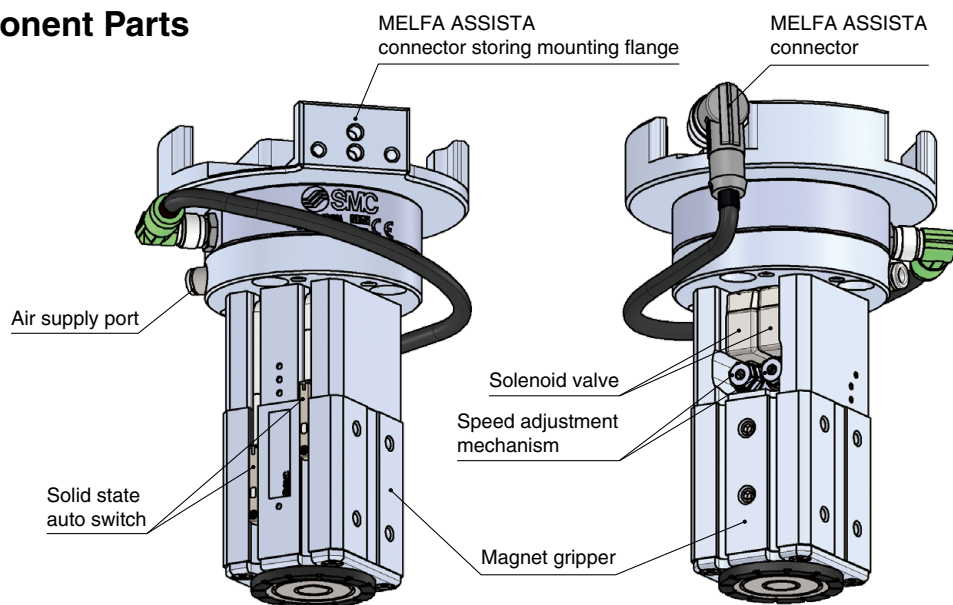

Learn more about the MHM series here.

How to Order



MHM-25D-X7400A-ASSISTA-P

Auto switch output type ●

Symbol	Auto switch model	Output type
Nil	D-M9N	NPN
P	D-M9P	PNP

Specifications

Fluid	Air	
Action	Double acting	
Operating pressure [MPa]	0.2 to 0.6	
Proof pressure [MPa]	0.9	
Ambient and fluid temperatures [°C]	-10 to 50 (No freezing)	
Holding force [N]	Workpiece thickness: 2 mm	160
	Workpiece thickness: 6 mm	200
Residual holding force [N]	0.3 or less	
Lubrication	Non-lube	
Weight [g]	780	
Standards	ISO9409-1-31.5-4-M5	
Auto switch model	D-M9N, D-M9P	
Connector type	M12 8-pin connector (Plug)	

■ **Included parts:** Connector storing flange, Mounting bolt, Positioning pin, Coil tube for piping ($\varnothing 4$), Piping fittings (2 types)

Characteristics

Holding force

The holding force graph shows the theoretical value for low-carbon steel plates. Holding forces vary depending on the material and shape of the workpiece. Please perform a holding test while referring to the value selected based on the graph.

MHM-25



Dimensions

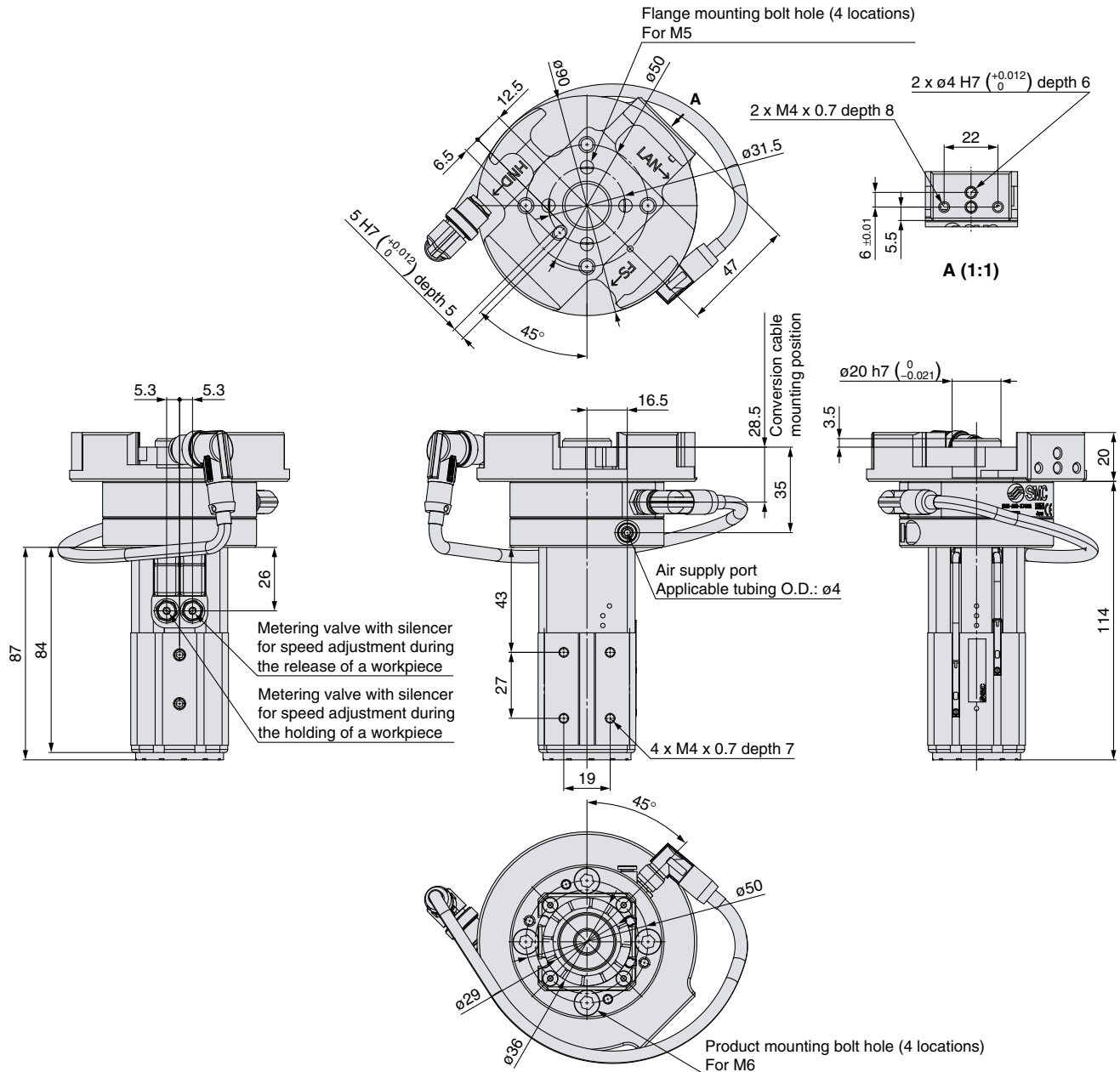



MHM-X7400A-ASSISTA

Specific Product Precautions

Be sure to read this before handling the products. For safety instructions, actuator precautions, magnet gripper specific product precautions, and auto switch precautions, refer to the “Handling Precautions for SMC Products” and the “Operation Manual” on the SMC website: <https://www.smcworld.com>

Handling

Caution

1. If pressure is applied to the external magnet gripper parts, there is a possibility that air will get inside the cylinder from the rod seal section. (Example: inside a chamber, etc.)
2. As the body magnets are built-in, do not allow close contact with magnetic disks, magnetic cards, or magnetic tapes. Data may be erased.

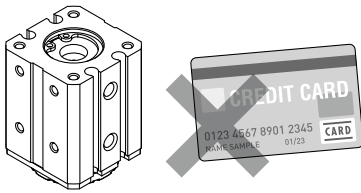

Mounting

Caution

1. For details on the mounting method, refer to the Operation Manual.
2. Tighten to the specified tightening torque. If the tightening torque is exceeded, the body and the mounting screws may break. However, insufficient torque may cause displacement of the body and loosening of the mounting screws.
3. Do not drop, strike, or apply excessive impact to this product.
Doing so may result in damage to the internal parts of the body, solenoid valve, or auto switch. In some cases, this damage may result in a malfunction.
4. Hold the body when handling the product. Do not pull excessively on the M12 connector cable or pinch the cable when lifting the body. Failure to do so may result in damage to the solenoid valve or auto switch. In some cases, this damage may result in a failure or malfunction.
5. The bolts may loosen due to the operating conditions and environment. Be sure to conduct maintenance such as tightening the bolts periodically.

Wiring

Caution

1. Avoid repeatedly bending or stretching the M12 connector cable as well as applying force to it.
2. Do not wire while energizing the product. Doing so may result in damage to the internal parts of the solenoid valve or auto switch. In some cases, this damage may result in a malfunction.
3. Do not disassemble the M12 connector cable or make any modifications, including additional machining. Doing so may cause human injury and/or an accident.

Piping

Caution

1. Flushing of the inside of the pipes

Before piping is connected, it should be thoroughly blown out with air (flushing) or washed to remove chips, cutting oil, and other debris from inside the pipe.

2. Tube attachment

- Take a tube having no flaws on its periphery and cut it off at a right angle. When cutting the tube, use tube cutters TK-1, 2, 3, 5, or 6. Do not use pliers, nippers, scissors, etc. If cutting is done with tools other than tube cutters, the tube may be cut diagonally or become flattened, etc., making a secure installation impossible, and causing problems such as the tube pulling out after installation or air leakage. Allow some extra length in the tube.
- Grasp the tube and push it in slowly, inserting it securely all the way into the fitting.
- After inserting the tube, pull on it lightly to confirm that it will not come out. If it is not installed securely all the way into the fitting, this can cause problems such as air leakage or the tube pulling out.

3. Tube detachment

- Push in the release button sufficiently, pushing its collar equally around the circumference.
- Pull out the tube while holding down the release button so that it does not come out. If the release button is not pressed down sufficiently, there will be increased bite on the tube and it will become more difficult to pull it out.
- When the removed tube is to be used again, cut off the portion which has been chewed before reusing it. If the chewed portion of the tube is used as is, this can cause trouble such as air leakage or difficulty in removing the tube.

4. Other Tube Brands

When using other than SMC brand tube, confirm that the following specifications are satisfied with respect to the tube outside diameter tolerance.

- Nylon tube within ± 0.1 mm
- Soft nylon tube within ± 0.1 mm
- Polyurethane tube within ± 0.15 mm, within -0.2 mm

Do not use tube which do not meet these outside diameter tolerances. It may not be possible to connect them, or they may cause other trouble, such as air leakage or the tube pulling out after connection.

5. Piping

- Do not apply unnecessary forces, such as twisting, pulling, moment loads, vibration, impact, etc., on fittings or tubing. This will cause damage to fittings and will crush, burst, or release tubing.
- Do not lift the product by the piping after the tube is connected. Doing so may result in damage to the One-touch tube fitting. For details, refer to the “Handling Precautions for SMC Products” on the SMC website: <https://www.smcworld.com>

Air Gripper for Collaborative Robots

Mitsubishi Electric Corporation collaborative robot

MELFA ASSISTA compliant



■ Compact, lightweight product with high gripping force due to air operation

■ An air gripper that realizes high rigidity and high precision due to its guide-integrated construction

With high-precision linear guide

Repeatability: ± 0.01 mm

Linear guide of the higher rigidity and precision is used.

Higher rigidity (Compared with the same size of the existing MHZ2)

■ Operate by simply connecting 1 compressed air supply tube and an electrical wiring M12 connector.

■ Integrated solenoid valve, speed adjustment mechanism, and auto switch

■ A split protective cover for easy air gripper maintenance

Allows you to maintain the air gripper without removing the user-specific attachment

Component Parts

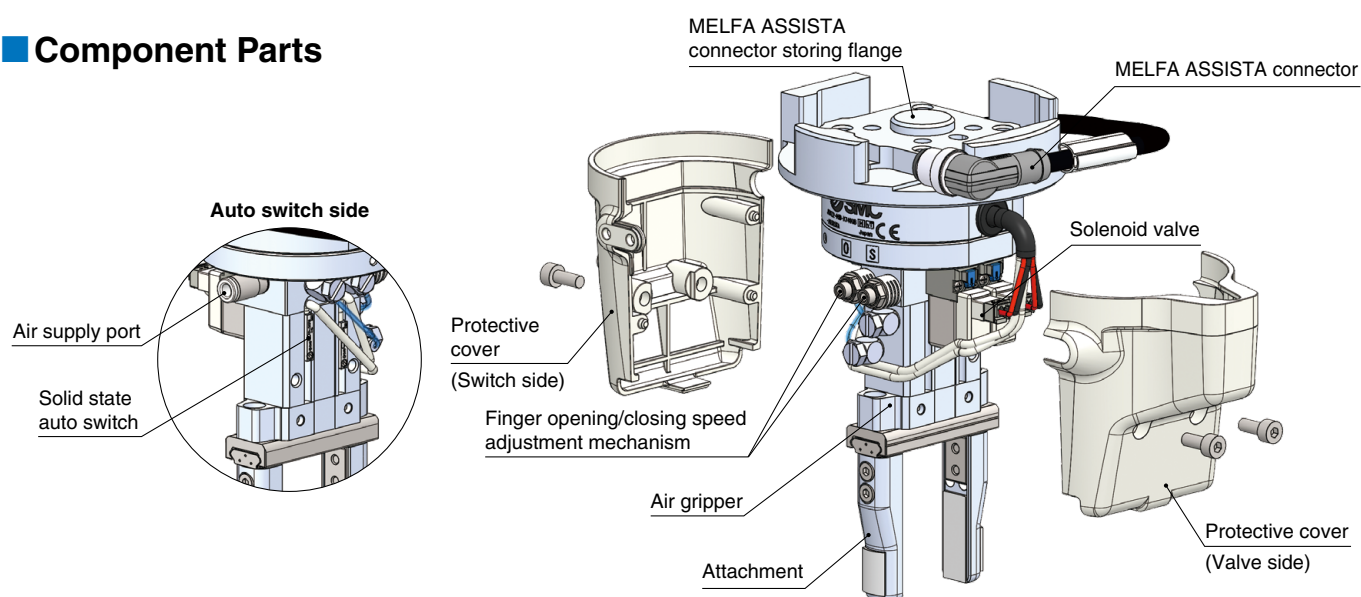

Vacuum Gripper

Magnet Gripper

Air Gripper

How to Order



JMHZ2-16D-X7400B-ASSISTA-P

Auto switch output type

Symbol	Auto switch model	Output type
N	D-M9N-5	NPN
P	D-M9P-5	PNP

Specifications

Bore size [mm]	16
Fluid	Air
Action	Double acting
Operating pressure [MPa]	0.1 to 0.7
Repeatability [mm]	± 0.01
Gripping force	External 32.7
Effective value per finger [N]	Internal 43.5
Opening/Closing stroke (Both sides) [mm]	10
Weight [g]	680
Standards	ISO9409-1-31.5-4-M5
Auto switch model	D-M9P-5, D-M9N-5
Connector type	M12 8-pin connector (Plug)

■ **Included parts:** Connector storing flange, Mounting bolt, Positioning pin, Coil tube for piping ($\phi 4$), Piping fittings (2 types)

Characteristics

Gripping force

● Indication of effective gripping force

The gripping force shown in the graphs below represents the gripping force of one finger when all fingers and attachments are in contact with the workpiece. **F** = One finger thrust

External gripping force

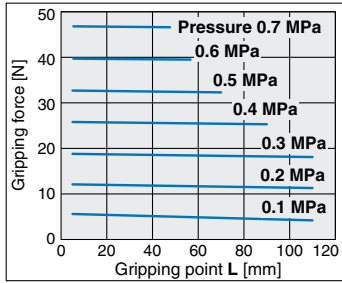
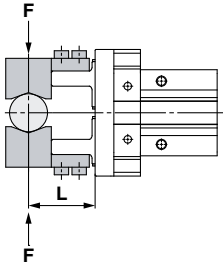

Internal gripping force

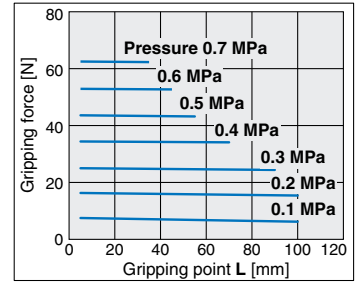
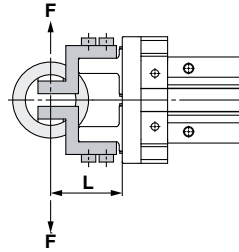

Gripping point

- The air gripper should be operated so that the workpiece gripping point "L" and the amount of overhang "H" stay within the range shown for each operating pressure given in the graphs below.
- If the workpiece gripping point goes beyond the range limits, this will have an adverse effect on the life of the air gripper.

External grip

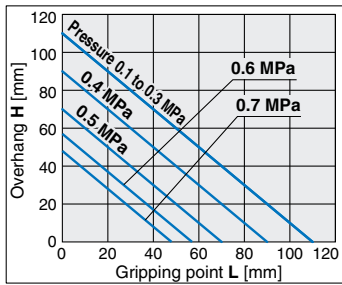
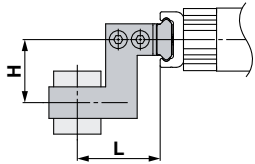

Internal grip

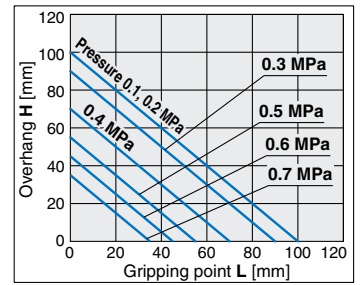
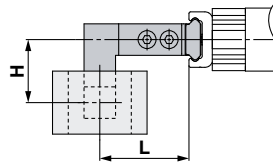

Dimensions

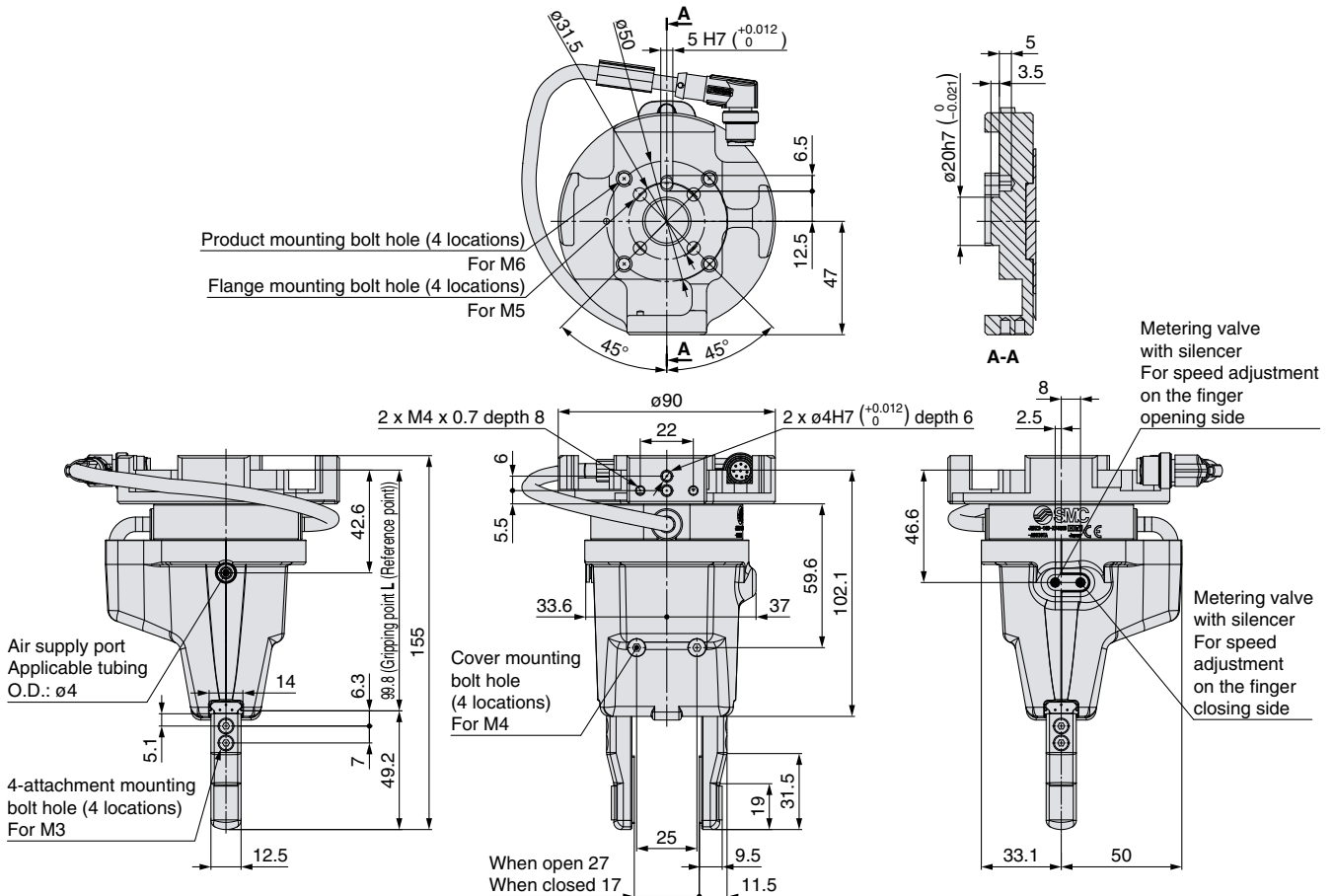

JMHZ2-X7400B-ASSISTA

Specific Product Precautions



Be sure to read this before handling the products. For safety instructions, air gripper precautions, air gripper specific product precautions, and auto switch precautions, refer to the “Handling Precautions for SMC Products” and the “Operation Manual” on the SMC website: <https://www.smcworld.com>

Handling

Caution

1. Martensitic stainless steel is used for the finger guide. However, the anti-corrosiveness of this steel is inferior to that of austenitic stainless steel. In particular, rust may be generated in environments where waterdrops are likely to adhere to the product due to condensation, etc.
2. Finite orbit type guide is used in the actuator finger part. By using this, when there are inertial force which cause by movements or rotation to the actuator, steel ball will move to one side and this will cause a large resistance and degrade the accuracy. When there are inertial force which cause by movements or rotation to the actuator, operate the finger to full stroke.
3. When mounting or removing the attachment, use the following tightening torque: 0.59 N. The weight of the attachment is generally about 70 g per side of a finger.

Mounting

Caution

1. For details on the mounting method, refer to the Operation Manual.
2. Tighten to the specified tightening torque. If the tightening torque is exceeded, the body and the mounting screws may break. However, insufficient torque may cause displacement of the body and loosening of the mounting screws.
3. Do not drop, strike, or apply excessive impact to this product.
Doing so may result in damage to the internal parts of the body, solenoid valve, or auto switch. In some cases, this damage may result in a malfunction.
4. Hold the body when handling the product. Do not pull excessively on the M12 connector cable or pinch the cable when lifting the body. Failure to do so may result in damage to the solenoid valve or auto switch. In some cases, this damage may result in a failure or malfunction.
5. The bolts may loosen due to the operating conditions and environment. Be sure to conduct maintenance such as tightening the bolts periodically.

Wiring

Caution

1. Avoid repeatedly bending or stretching the M12 connector cable as well as applying force to it.
2. Do not wire while energizing the product. Doing so may result in damage to the internal parts of the solenoid valve or auto switch. In some cases, this damage may result in a malfunction.
3. Do not disassemble the M12 connector cable or make any modifications, including additional machining. Doing so may cause human injury and/or an accident.

Piping

Caution

1. **Flushing of the inside of the pipes**
Before piping is connected, it should be thoroughly blown out with air (flushing) or washed to remove chips, cutting oil, and other debris from inside the pipe.
2. **Tube attachment**
 - Take a tube having no flaws on its periphery and cut it off at a right angle. When cutting the tube, use tube cutters TK-1, 2, 3, 5, or 6. Do not use pliers, nippers, scissors, etc. If cutting is done with tools other than tube cutters, the tube may be cut diagonally or become flattened, etc., making a secure installation impossible, and causing problems such as the tube pulling out after installation or air leakage. Allow some extra length in the tube.
 - Grasp the tube and push it in slowly, inserting it securely all the way into the fitting.
 - After inserting the tube, pull on it lightly to confirm that it will not come out. If it is not installed securely all the way into the fitting, this can cause problems such as air leakage or the tube pulling out.
3. **Tube detachment**
 - Push in the release button sufficiently, pushing its collar equally around the circumference.
 - Pull out the tube while holding down the release button so that it does not come out. If the release button is not pressed down sufficiently, there will be increased bite on the tube and it will become more difficult to pull it out.
 - When the removed tube is to be used again, cut off the portion which has been chewed before reusing it. If the chewed portion of the tube is used as is, this can cause trouble such as air leakage or difficulty in removing the tube.
4. **Other Tube Brands**
When using other than SMC brand tube, confirm that the following specifications are satisfied with respect to the tube outside diameter tolerance.
 - Nylon tube within ± 0.1 mm
 - Soft nylon tube within ± 0.1 mm
 - Polyurethane tube within ± 0.15 mm, within -0.2 mmDo not use tube which do not meet these outside diameter tolerances. It may not be possible to connect them, or they may cause other trouble, such as air leakage or the tube pulling out after connection.
5. **Piping**
 - Do not apply unnecessary forces, such as twisting, pulling, moment loads, vibration, impact, etc., on fittings or tubing. This will cause damage to fittings and will crush, burst, or release tubing.
 - Do not lift the product by the piping after the tube is connected. Doing so may result in damage to the One-touch tube fitting. For details, refer to the “Handling Precautions for SMC Products” on the SMC website: <https://www.smcworld.com>

Safety Instructions

These safety instructions are intended to prevent hazardous situations and/or equipment damage. These instructions indicate the level of potential hazard with the labels of “**Caution**,” “**Warning**” or “**Danger**.” They are all important notes for safety and must be followed in addition to International Standards (ISO/IEC)*1), and other safety regulations.

 **Caution:** **Caution** indicates a hazard with a low level of risk which, if not avoided, could result in minor or moderate injury.

 **Warning:** **Warning** indicates a hazard with a medium level of risk which, if not avoided, could result in death or serious injury.

 **Danger:** **Danger** indicates a hazard with a high level of risk which, if not avoided, will result in death or serious injury.

*1) ISO 4414: Pneumatic fluid power – General rules relating to systems.
ISO 4413: Hydraulic fluid power – General rules relating to systems.
IEC 60204-1: Safety of machinery – Electrical equipment of machines.
(Part 1: General requirements)
ISO 10218-1: Manipulating industrial robots – Safety.
etc.

Warning

1. The compatibility of the product is the responsibility of the person who designs the equipment or decides its specifications.

Since the product specified here is used under various operating conditions, its compatibility with specific equipment must be decided by the person who designs the equipment or decides its specifications based on necessary analysis and test results. The expected performance and safety assurance of the equipment will be the responsibility of the person who has determined its compatibility with the product. This person should also continuously review all specifications of the product referring to its latest catalog information, with a view to giving due consideration to any possibility of equipment failure when configuring the equipment.

2. Only personnel with appropriate training should operate machinery and equipment.

The product specified here may become unsafe if handled incorrectly. The assembly, operation and maintenance of machines or equipment including our products must be performed by an operator who is appropriately trained and experienced.

3. Do not service or attempt to remove product and machinery/equipment until safety is confirmed.

1. The inspection and maintenance of machinery/equipment should only be performed after measures to prevent falling or runaway of the driven objects have been confirmed.
2. When the product is to be removed, confirm that the safety measures as mentioned above are implemented and the power from any appropriate source is cut, and read and understand the specific product precautions of all relevant products carefully.
3. Before machinery/equipment is restarted, take measures to prevent unexpected operation and malfunction.

4. Contact SMC beforehand and take special consideration of safety measures if the product is to be used in any of the following conditions.

1. Conditions and environments outside of the given specifications, or use outdoors or in a place exposed to direct sunlight.
2. Installation on equipment in conjunction with atomic energy, railways, air navigation, space, shipping, vehicles, military, medical treatment, combustion and recreation, or equipment in contact with food and beverages, emergency stop circuits, clutch and brake circuits in press applications, safety equipment or other applications unsuitable for the standard specifications described in the product catalog.
3. An application which could have negative effects on people, property, or animals requiring special safety analysis.
4. Use in an interlock circuit, which requires the provision of double interlock for possible failure by using a mechanical protective function, and periodical checks to confirm proper operation.

Caution

1. The product is provided for use in manufacturing industries.

The product herein described is basically provided for peaceful use in manufacturing industries.
If considering using the product in other industries, consult SMC beforehand and exchange specifications or a contract if necessary.
If anything is unclear, contact your nearest sales branch.

Limited warranty and Disclaimer/ Compliance Requirements

The product used is subject to the following “Limited warranty and Disclaimer” and “Compliance Requirements”.

Read and accept them before using the product.

Limited warranty and Disclaimer

1. The warranty period of the product is 1 year in service or 1.5 years after the product is delivered, whichever is first.*2)
Also, the product may have specified durability, running distance or replacement parts. Please consult your nearest sales branch.
2. For any failure or damage reported within the warranty period which is clearly our responsibility, a replacement product or necessary parts will be provided.
This limited warranty applies only to our product independently, and not to any other damage incurred due to the failure of the product.
3. Prior to using SMC products, please read and understand the warranty terms and disclaimers noted in the specified catalog for the particular products.

*2) Vacuum pads are excluded from this 1 year warranty.

A vacuum pad is a consumable part, so it is warranted for a year after it is delivered.
Also, even within the warranty period, the wear of a product due to the use of the vacuum pad or failure due to the deterioration of rubber material are not covered by the limited warranty.

Compliance Requirements

1. The use of SMC products with production equipment for the manufacture of weapons of mass destruction (WMD) or any other weapon is strictly prohibited.
2. The exports of SMC products or technology from one country to another are governed by the relevant security laws and regulations of the countries involved in the transaction. Prior to the shipment of a SMC product to another country, assure that all local rules governing that export are known and followed.

Caution

SMC products are not intended for use as instruments for legal metrology.

Measurement instruments that SMC manufactures or sells have not been qualified by type approval tests relevant to the metrology (measurement) laws of each country. Therefore, SMC products cannot be used for business or certification ordained by the metrology (measurement) laws of each country.

Safety Instructions

Be sure to read the “Handling Precautions for SMC Products” (M-E03-3) and “Operation Manual” before use.