

Desktop Duster Box

ZVB Series

Integrated the static neutralization, dust removal and dust collection processes into one box!

Static neutralization

Adopted a dedicated ionizer with improved static neutralization efficiency.



RoHS

3 functions in 1 unit!
All in one

Blow nozzle with improved dust removal efficiency

Dust removal

Dust collection

Pneumatic dust collector enables quick dust collection response.



A4 size [ZVB20]

210 x 297 mm (Dimensions)
202 x 212 mm (Static neutralization space)



A3 size [ZVB40]

400 x 384 mm (Dimensions)
392 x 298 mm (Static neutralization space)

IZS

IZN

IZF

ZVB

IZD

IZE

IZH

Supports workpieces of various sizes.

- Smartphone
- Lens
- Lamp cover
- Cosmetic case
- Electronic components
- Parts for home appliances

Static neutralization

Dust removal

Dust collection

3 functions in 1 unit! All in one

Improved the static neutralization and dust removal efficiency with a separate ion blow and air blow structure!

Ionizer

Offset voltage: ± 10 v
* Static neutralization distance: 100 mm

Discharge time: 0.3 s
* 1000 V → 100 V

4 Secured a large static neutralization space.

Reduced the dust collector space using a pneumatic dust collector (vacuum flow), to secure the static neutralization space to the utmost.

Model	Size	Static neutralization space (Width x Depth) [mm]
ZVB20	A4	202 x 212
ZVB40	A3	392 x 298

Photoelectric sensor

Photoelectric sensor reflecting plate is installed on the upper surface in the box. Sensor detects a workpiece and starts the operation.

Static neutralization

1 Minimized attenuation of ion

Separate ion blow/air blow structure. Reduced the attenuation of the ion by an air blow.

2 Adopted a nozzle that neutralizes static electricity in a wide range.

Adopted a diffusion type nozzle for the ionizer, so that ionized air reaches all corners of the box. Supports an extensive range of large workpieces.

3 Easy maintenance of emitter

Since the emitter can be removed easily, replacement and cleaning can also be performed easily.

Dust removal

5 Nozzle dedicated for the blow without impairing the generation efficiency of the ion

Equipped with an additional air blow nozzle only for dust removal. Besides the ionized air, the angle and flow rate of the air blow can be adjusted (Optional). The pressure can also be adjusted with an additional air blow pressure regulator installed on the back side of the body.

Dust collection

6 Adopted a maintenance-free pneumatic dust collector.

Since a built-in pneumatic dust collector blows the sucked in dust to the exhaust port by the power of compressed air, dust will not remain inside the dust collector. The maintenance-free dust collector without a drive unit also reduces the risks of malfunction.

7 Quick dust collection response

The pneumatic dust collector starts collecting dust immediately after the built-in solenoid valve is opened. Reduces the cycle time with a quick response, from the input of an electrical signal to the start of suction.

Desktop Duster Box

ZVB Series

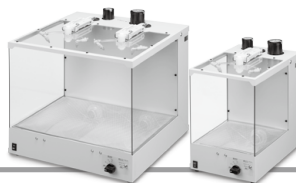

How to Order

ZVB **20** - **B** **S** **A** - **□**

① ② ③ ④ ⑤

① Size

20
40

② Additional air blow

B	With additional air blow
----------	--------------------------

③ Photoelectric sensor

Nil	None <small>Note 1)</small>
S	With photoelectric sensor <small>Note 2)</small>

Note 1) It is necessary to connect an external switch to the external input terminal on the back side of the product.

Note 2) This is a regression reflection type photoelectric sensor. Completely transparent workpieces detection is not available.

④ AC adapter

Nil	None (exclusive DC plug attached)
A	With AC adaptor <small>Note 3)</small>

Note 3) The AC power supply cable attached to the product has the configuration applicable to socket of 100 VAC. The cap needs to be changed when the cable is connected to a socket of voltage other than 100 VAC.

⑤ Option Note 4)

Nil	None
D	With 3 m exhaust duct hose (hose band attached)
P	With dust collecting bag (hose band attached)
S	With additional air blow adjustment needle valve

Note 4) When two or more options are specified, indicate them alphabetically.

Options (* The number of sets provided when selected in ⑤ differs by the size.)

① 3 m exhaust duct hose

Model: ZVB-D3A

* ZVB20...1 set
ZVB40...2 sets



② Dust collecting bag

Model: ZVB-P1A

* ZVB20...1 set
ZVB40...2 sets



③ AC adapter

Model: ZVB-AC1



④ Emitter

Model: IZN10-NT-X325



⑤ Additional air blow nozzle

Model: ZVB-N10A



⑥ Suction slope (For ZVB20)

Model: ZVB-V20A



⑦ Suction slope (For ZVB40)

Model: ZVB-V40A



Specifications

Component	Item	Model	ZVB20	ZVB40
			Nozzle type	
Ionizer	Type		Nozzle type	
	Number of mounted units		1	2
	Ion generation method		Corona discharge type	
	Method of applying voltage		High frequency AC type	
	Discharge time		0.3 s (1000 V→100 V)	
	Offset voltage		Within ±10 V (Static neutralization distance: 100 mm from the nozzle)	
Dust collector	Type		Pneumatic type, Vacuum flow	
	Number of mounted units		1	2
	Supply pressure range		0.1 to 0.7 MPa	
	Exhaust flow rate		410 to 1580 L/min (ANR)	820 to 3160 L/min (ANR)
Body	Fluid		Air (Dry air)	
	Operating pressure range		0.2 to 0.8 MPa	
	Power supply voltage		85 to 264 VAC 50/60 Hz (when using the exclusive AC adaptor)	
	Operating time setting		Continuous/Timer [2/5/10 s]	
	Additional air blow setting		Continuous blow/Pulse blow [50/100 ms intervals]	
	Operating temperature range		0 to 55°C <small>Note 1)</small>	
	Air consumption <small>Note 2)</small>		420 L/min (ANR)	800 L/min (ANR)
Weight <small>Note 3)</small>		5.1 kg	9.9 kg	

Note 1) No freezing

Note 2) When supply pressure to the dust collector is set to 0.3 MPa (ZVB20)/0.4 MPa (ZVB40) and additional air blow supply pressure to 0.2 MPa. Based on SMC's measuring conditions.

Note 3) Overall weight excluding optional parts

IZS

IZN

IZF

ZVB

IZD

IZE

IZH

ZVB Series

Air Circuit Diagram

ZVB20

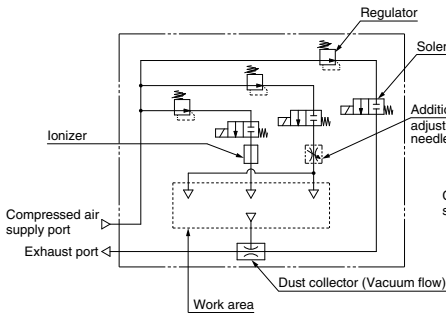

ZVB40

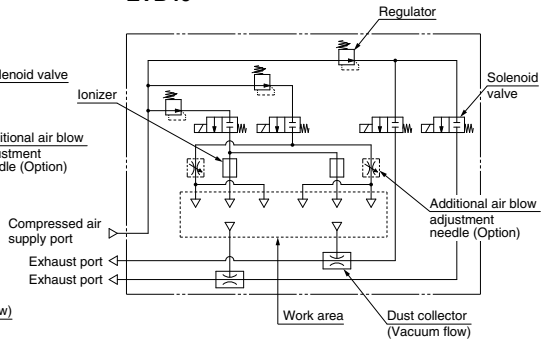

Construction

(Photo shows the ZVB20.)

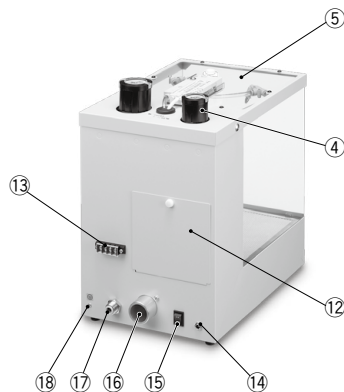
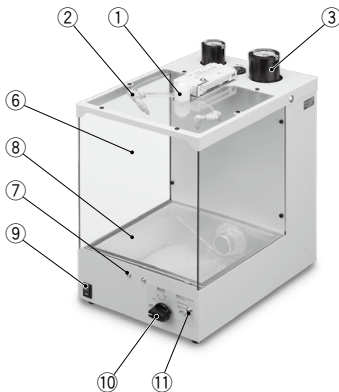

Component Parts*

No.	Description	Note
1	Ionizer	ZVB20: 1 unit, ZVB40: 2 units. With diffusion nozzle
2	Additional air blow nozzle	ZVB20: 2 pcs., ZVB40: 4 pcs., Nozzle diameter: $\phi 1.0$
3	Regulator for adjusting supply pressure to the dust collector	With pressure gauge
4	Regulator for adjusting supply pressure for additional air blow	With pressure gauge
5	Top cover assembly	Static electricity restriction grade (PET)
6	Side cover	Static electricity restriction grade (PET)
7	Photoelectric sensor	ZVB20: 1 pc., ZVB40: 2 pcs., Reflection type (built into the body)
8	Mesh	Detachable
9	Power supply switch	
10	Operation time set switch	Continuous/2 s/5 s/10 s

No.	Description	Note
11	Additional air blow pulse operation time set switch	Continuous (no pulse)/50 ms/100 ms
12	Cover for valve maintenance	Used when replacing the built-in valve
13	Terminal block	Signal output/External input/COM+/COM-
14	AC adapter (DC plug) entry	
15	ON/OFF switch for dust collector	
16	Exhaust port of the dust collector	ZVB20: 1 port, ZVB40: 2 ports. Exhaust duct hose connection port(O.D.: $\phi 32$)
17	Compressed air supply port	ZVB20: $\phi 8$, ZVB40: $\phi 10$
18	Grounding screw	

* Although the components are common to the ZVB20 and ZVB40, the number of attached parts differs. (Refer to the note column.)

Operation Flow

The following shows the operating sequence during continuous operation and timer operation with the photoelectric sensor.

- 1 Main unit operation**
The photoelectric sensor detects the workpiece.

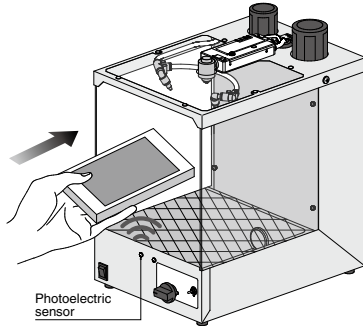

- 4 Stop of static neutralization and dust removal**

The operation of the ionizer (static neutralization) and the additional air blow (dust removal) stops by the progression of the set time (2/5/10 seconds), or the OFF detection of the photoelectric sensor after a workpiece is removed. (However, the dust collector continues to operate for 0.5 seconds.)

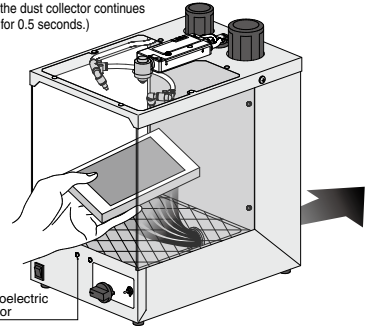

IZS

IZN

IZF

ZVB

IZD

IZE

IZH

- 2 Start of dust collection**
The dust collector (vacuum flow) is activated, and starts the dust collection.

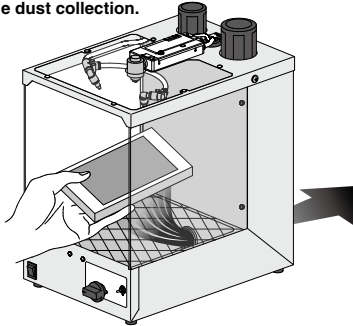

- 5 Stop of dust collection**
Stops the operation of the dust collector (vacuum flow).

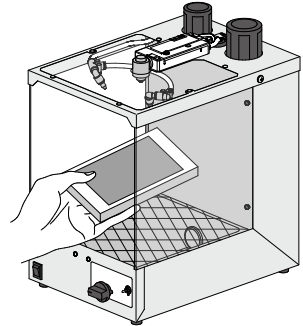

- 3 Start of static neutralization and dust removal**
The dust collector (vacuum flow) is activated, and starts the ionizer (static neutralization) and the additional air blow (dust removal) after 0.5 seconds.
* The additional air blow can be set to continuous or pulse (50/100 ms intervals).

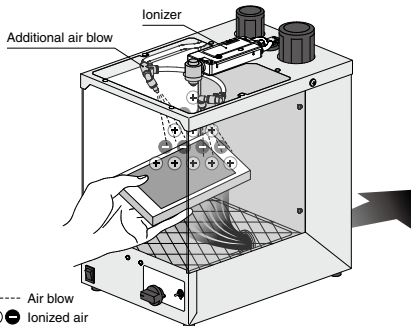

- 6 Remove the workpiece.**

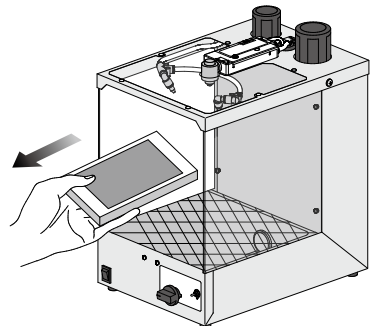

ZVB Series

Dimensions

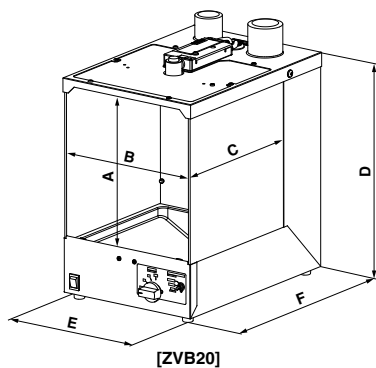
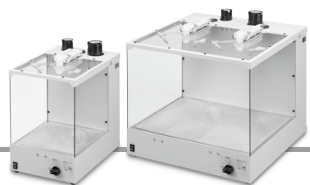

[ZVB20]

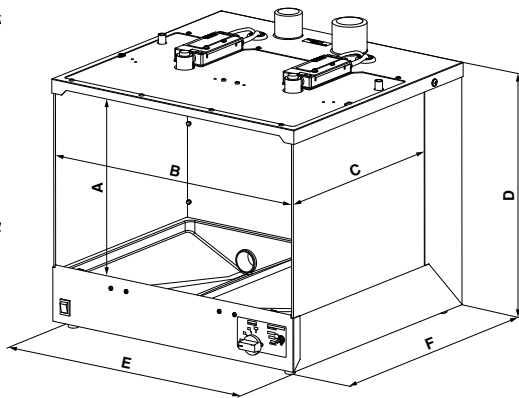

[ZVB40]

Model	A	B	C	D	D* ^{Note 1)}	E	F	F* ^{Note 2)}
ZVB20	211	202	212	310	351	210	297	341
ZVB40	248	392	298	349	390	400	384	428

Note 1) Dimension D' is the overall height including the knob of the regulator.

Note 2) Dimension F' is the overall depth including the switch lever on the front and the exhaust port on the back.

Refer to the operation manual for detailed dimensions.



ZVB Series

Specific Product Precautions

Be sure to read this before handling the products.

Installation/Mounting

Warning

1. **Avoid using in a place where noise (electromagnetic wave and surge) is generated.**

It may cause failure or damage to the product. Take measures to prevent noise at source and avoid power and signal lines from coming into close contact.

2. **Do not allow foreign matter, workpiece or tool to enter the ionizer nozzle.**

There is an emitter inside the nozzle. If the emitter gets in contact with metallic workpieces or tools, electrical shock may cause injury. If emitter is damaged, it may interfere with the specified function and performance, and may also cause operation failure and accident.

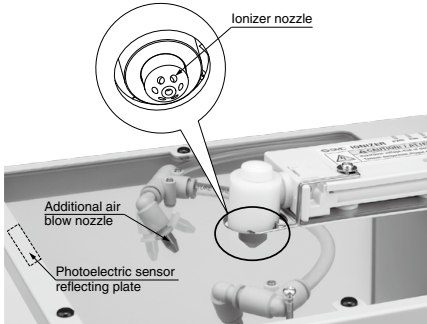

(In addition to the ionizer nozzle, the additional air blow nozzle and photoelectric sensor reflecting plate are installed on the upper surface in the box. Avoid these items being in a collision with a workpiece.)

3. **When the dust collector is operating, air is discharged vigorously from the exhaust port.**

Prevent exhausted air from contacting people or objects. Piping (I.D. 32 mm) or dust collecting bag must be connected to the exhaust port.

Wiring/Piping

Warning

1. **Power supply required to the product is 24 VDC and 1 A.**

When power is supplied to the product without using the exclusive AC adapter, make sure to use a stabilization power supply and connect wiring to the DC plug that is provided with the product as an accessory.

2. **D-class ground connection must be used to the product.**

Without grounding, the product will not provide the designed performance.

3. **For air piping, use SMC or equivalent tubing of diameter 8 mm (for ZVB20) or 10 mm (for ZVB40). It is strongly recommended to use clean dry air (with a dew point at approximately -20°C).**

4. **Air connections should only be made with the pressure supply turned off.**

Flush the system before piping to prevent foreign matter from entering inside the product.

Operating Environment

Warning

1. **Operate in an environment in the specified ambient temperature and fluid temperature ranges (0 to 55°C).**

Avoid sudden temperature changes even within specified temperature range, as it may cause condensation.

2. **Do not use this product in an enclosed space. This product utilizes the corona discharge phenomenon.**

Although the amount is very small, Ozone and NOx are generated. Ozone condensation can increase if used in an enclosed space, which can affect the human body, so ventilation is necessary.

3. **Effects on implantable medical devices**

The electromagnetic waves emitted from this product may interfere with implantable medical devices such as cardiac pacemakers and cardioverter defibrillators, resulting in the malfunction of the medical device or other adverse effects. Please use extreme caution when operating equipment which may have an adverse effect on your implantable medical device. Be sure to thoroughly read the precautions stated in the catalog, operation manual, etc., of your implantable medical device, or contact the manufacturer directly for further details on what types of equipment need to be avoided.

Maintenance

Warning

1. **Perform maintenance regularly and clean the emitters. (every 2 weeks suggested.)**

The maintenance must be performed by an operator who has sufficient knowledge and experience. If the ionizer is used for a long time and there is dust on the emitters, performance of the product will be reduced. When the NDL LED (maintenance signal LED) is ON, the emitter will need to be cleaned. If the emitter gets worn and static neutralization ability does not recover even after cleaning, replace the emitter. (Emitter part no.: IZN10-NT-X325)

2. **Before starting inspection, cleaning or replacing the emitter, or replacing the valves, be sure to turn OFF the power and air supply to the main body to prevent electric shocks or accidents.**

Handling

Caution

1. **Do not drop, hit or apply excessive shock to the product.**

Even if the body is not damaged, the internal components may be damaged, leading to a malfunction.

IZS

IZN

IZF

ZVB

IZD

IZE

IZH