

500 HC VALVE WITH T15 ELECTRICAL ACTUATOR

FEATURES

The brass 2-way ball valve 500 HC+T15 provides the automatic shut-off function for thermally insulated piping for usual fluids: water, air, hydrocarbons. It is a full-bore valve. It is EC- and ACS-approved (French health compliance certificate). The ISO 5211 mounting pad enables the actuator to be directly assembled. The latter is suitable for S4-30-type light service factors installed indoors or outdoors under shelter. 2-wire wiring - Return via capacitor

AVAILABLE MODELS

CW 617N brass body.
1/2" to 2" diameters.
G thread connections

Supply voltages: 12-24V AC-DC and 110-230 V AC.



LIMITS OF USE

Fluid pressure: PS	16 bar
Fluid temperature: WT	- 10°C / + 100°C
Ambient temperature	- 15°C / + 50°C
Service factor	S4 – 30 %

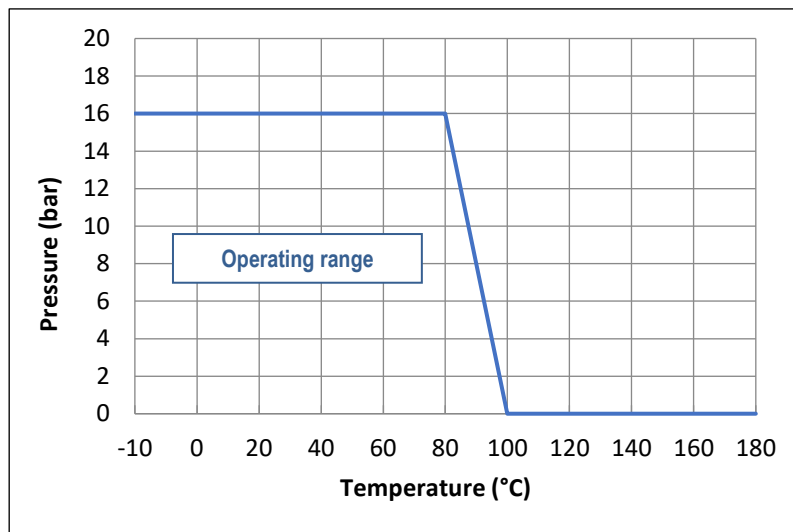

DIRECTIVES AND MANUFACTURING STANDARDS

OBJECT	Standard	ON
Pressure Equipment Directive 2014/68/EC	1/4" to 1" : not subject	
	1" 1/4 to 2" : category II	PASCAL 1115
Use for drinking water	A.C.S.	08 ACC LY 074
Connection Motorisation	ISO 5211:	

Information given as an indication only, and subject to possible modifications

	SECTORIEL S.A. 45 rue du Ruisseau 38290 SAINT QUENTIN-FALLAVIER – FRANCE Telephone: +33 4 74 94 90 70 - Fax: +33 4 74 94 13 95 www.sectoriel.com / Email : sectoriel@sectoriel.fr	Pages	1/3
		Ref.	FT500HC+T15 ENG
		Rev.	02
		Date	12/2022

500 HC VALVE WITH T15 ELECTRICAL ACTUATOR

CONSTRUCTION

No.	Item name	Material	No.	Name	Material
1	Body	Nickel-plated CW 617N brass	7	Anti-friction ring	PTFE
2	Ball	Chromium-plated CW 614 brass	8	Anti-friction coupling	PTFE
3	O-ring	NBR	9	Stem	CW 614N brass
4	Motorisation flange	Nickel-plated CW 617N brass	10	O-ring	FPM
5	Nut	CW 614N brass	11	Seat	PTFE
6	Nut	CW 614N brass	12	End	Nickel-plated CW 617N brass
			13	Guiding ring	CW 614N brass

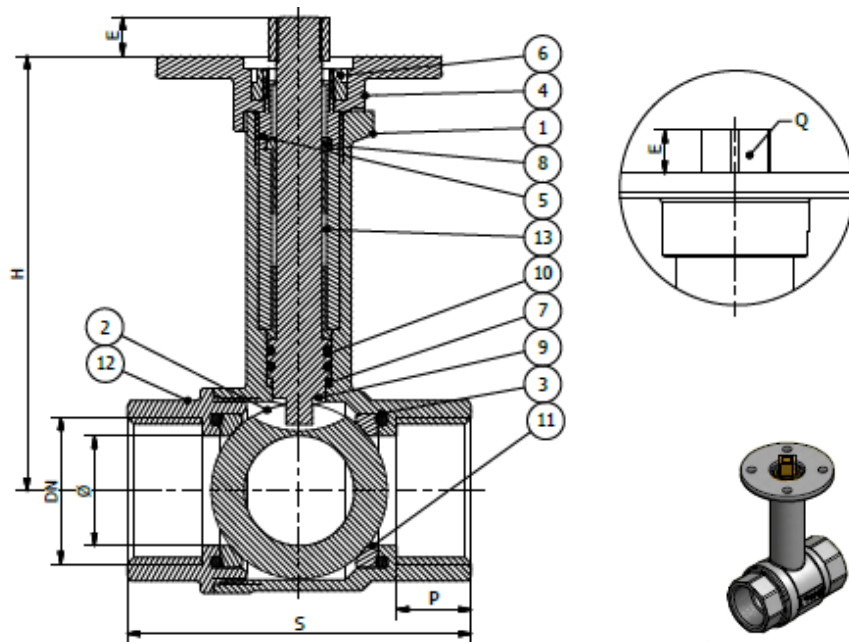

DIMENSIONS (mm)

DN	1/2"	3/4"	1"	1"1/4	1"1/2	2"
Ø	15	20	25	32	39	48
S	56	68	78	90	100	115
P	14	16	17	18	19	21
H	89	92	98	108	114	131
E	8	8	8	10	10	10
Q	11	11	11	11	11	11
ISO	F05	F05	F05	F05	F05	F05

Information given as an indication only, and subject to possible modifications

	SECTORIEL S.A. 45 rue du Ruisseau 38290 SAINT QUENTIN-FALLAVIER – FRANCE Telephone: +33 4 74 94 90 70 - Fax: +33 4 74 94 13 95 www.sectoriel.com / Email : sectoriel@sectoriel.fr	Pages	2/3
		Ref.	FT500HC+T15 ENG
		Rev.	02
		Date	12/2022

500 HC VALVE WITH T15 ELECTRICAL ACTUATOR

T15 ELECTRIC MOTORISATION

The TCR motorisation proposed as standard comprises:

- IP67 plastic housing for actuator and steel gear box,
- a safety coefficient of 1.3 minimum compared to the nominal torque of the valve,
- an upstream / downstream pressure difference $\Delta P=10$ bar max.

The actuator's assembly is direct.

DN	Actuator	Power 110-230V AC	Power 12V DC-24V AC-DC	Time	Standard equipment of the actuator
1/2"	T15	30	20	12s	2-wire wiring - capacitor return NF version perpendicular to the direction of the fluid 2 adjustable limit switches 2 dry auxiliary contacts Thermal protection of the motor Stand-by manual control with key Position visual indicator Electrical connection: 1 x PE M12 + 1.5m cable
3/4"	T15	30	20	12s	
1"	T15	30	20	12s	
1" 1/4	T15	30	20	12s	
1" 1/2	T15	30	20	12s	
2"	T15	30	20	12s	

For any other operating conditions, please contact us.

* indicative time for actuator running empty

Information given as an indication only, and subject to possible modifications

	SECTORIEL S.A. 45 rue du Ruisseau 38290 SAINT QUENTIN-FALLAVIER – FRANCE Telephone: +33 4 74 94 90 70 - Fax: +33 4 74 94 13 95 www.sectoriel.com / Email : sectoriel@sectoriel.fr	Pages	3/3
		Ref.	FT500HC+T15 ENG
		Rev.	02
		Date	12/2022

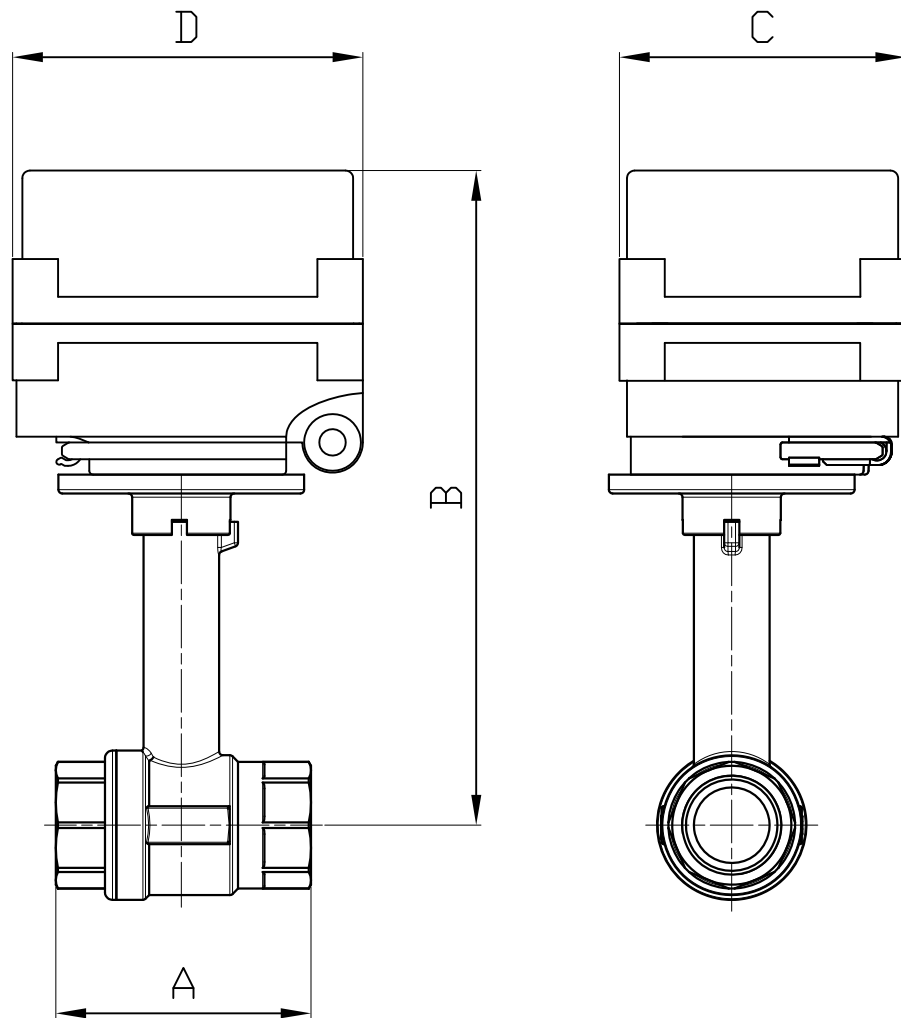

DN	1/2"	3/4"	1"	1 1/4"	1 1/2"	2"
SERVO	T15	T15	T15	T15	T15	T15
A	56	68	78	90	100	115
B	169.4	172.4	178.4	188.4	194.4	211.4
C	75.7	75.7	75.7	75.7	75.7	75.7
D	92.6	92.6	92.6	92.6	92.6	92.6
KG	0.99	1.12	1.4	1.76	2.01	2.78

Informations données à titre indicatif et sous réserve de modifications éventuelles
data subject to alteration

Ech:	Date	Dessiné par	Tolérances générales	Modifications	Date	REV.
/	:05/09/2019	: E.D.	: +/- 0.2			
ROBINET A TOURNANT SPHERIQUE 500HC/BALL VALVE 500HC + SERVOMOTEUR T15/ELECTRIC ACTUATOR T15				Matière :		
				Poids (Kg) :		
				Traitement : SANS		
45, Rue du Ruisseau 38297 SAINT QUENTIN FALLAVIER				Plan n° Ens 1379		

T15 ELECTRICAL ACTUATOR

FEATURES

The ultra-compact T15 electric actuator is intended for motorising under on/off operation the ¼ turn valves with a torque of at most 10 Nm. It is supplied via 2 wires and return to position using a capacitor. With a compact construction and plastic housing, it is especially well suited for motorising small diameter ball valves. **IP67 leak-tightness** : for indoor use and possibly outdoors under shelter.

AVAILABLE MODELS

Supply voltages : 230V AC and 12-24V AC-DC

LIMITS OF USE

IP Code	IP 67
Ambient temperature	-15°C / +50°C
Service factor	S4 – 30%



MECHANICAL FEATURES

Gear box	treated steel pinions
Torque	15 Nm
Angle of rotation	90° +/- 2°
Manoeuvring time	12 s
ISO 5211:	F03 / F05 – star 11
Declutching	Without
Override control	Using a hex key
Weight	1.000 kg

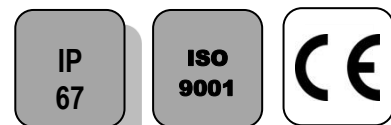

ELECTRICAL FEATURES

Power	230 V AC: 30 W	24 V AC: 20 W
Overheating	Thermal protection	
Limit switches	2 adjustable switches	
Auxiliary switches	2 dry contacts	
Anti-condensation	Without	
Electrical connection	PE M12 + 1.5 m cable	

Information given as an indication only, and subject to possible modifications

	SECTORIEL S.A. 45 rue du Ruisseau 38290 SAINT QUENTIN-FALLAVIER – FRANCE Telephone: +33 4 74 94 90 70 – Fax: +33 4 74 94 13 95 www.sectoriel.com / Email : sectoriel@sectoriel.fr	Pages	1/3
		Ref.	FT2250 ENG
		Rev.	02
		Date	12/2022

T15 ELECTRICAL ACTUATOR

CONSTRUCTION

Housing	PA Plastic	Limit switch A	Steel
Gear box	Treated steel	Limit switch B	Steel
ISO mounting pad	Steel	Condenser	
Limit cams	Steel	Position indicator	

DIMENSIONS (mm)

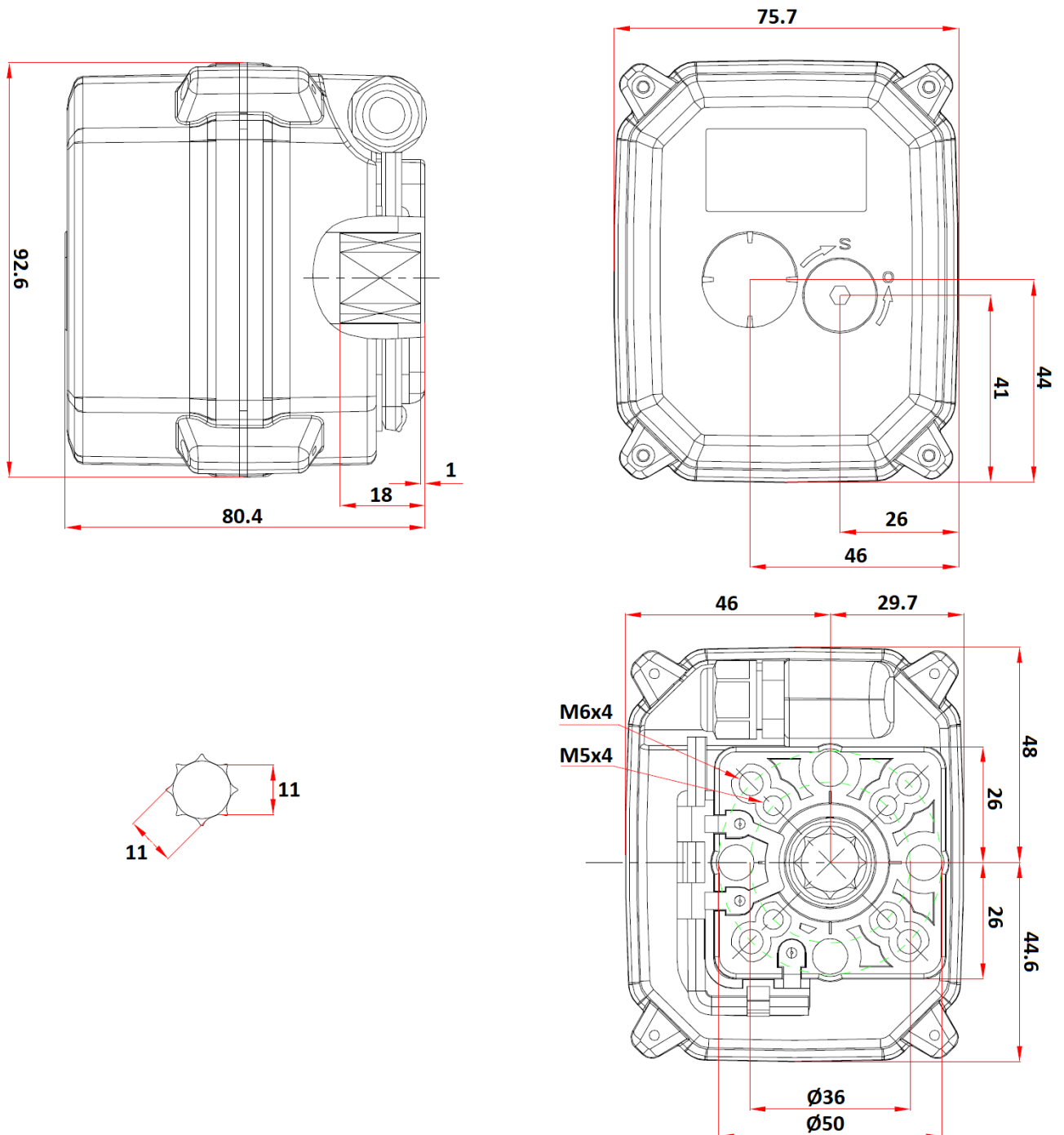

Information given as an indication only, and subject to possible modifications

	SECTORIEL S.A. 45 rue du Ruisseau 38290 SAINT QUENTIN-FALLAVIER – FRANCE Telephone: +33 4 74 94 90 70 – Fax: +33 4 74 94 13 95 www.sectoriel.com / Email : sectoriel@sectoriel.fr	Pages	2/3
		Ref.	FT2250 ENG
		Rev.	02
		Date	12/2022

T15 ELECTRICAL ACTUATOR

WIRING DIAGRAM

	Wire	Wiring
RD	red	Common
BK	black	Phase
GR	Green	Auxiliary switch "O"
YW	yellow	Auxiliary switch "F"
WT	White	Common contact

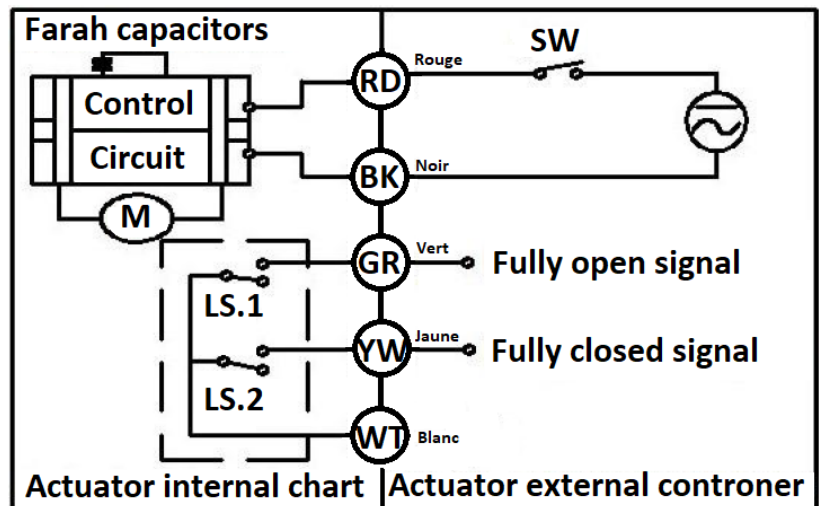

SWITCH SETTING

The cams are attached to the drive stem

2. Clockwise rotation = valve closing. The micro-switch stops the actuator.
3. Anti-clockwise rotation = valve opening. The micro-switch stops the actuator.

Information given as an indication only, and subject to possible modifications



SECTORIEL S.A.
 45 rue du Ruisseau
 38290 SAINT QUENTIN-FALLAVIER – FRANCE
 Telephone: +33 4 74 94 90 70 – Fax: +33 4 74 94 13 95
www.sectoriel.com / Email : sectoriel@sectoriel.fr

Pages	3/3
Ref.	FT2250 ENG
Rev.	02
Date	12/2022