

710-711XS VALVE WITH AP-RE PNEUMATIC ACTUATOR

FEATURES

The 711 XS + AP-RE 2-way ball valve is designed for the automatic shut-off of networks of non-loaded industrial fluids, up to a pressure of 40 bar. This 3-piece external tie-bolt ball valve is easy to remove for servicing. This full-bore valve has an anti-static device and double sealing at the cable gland. It is EC-, ATEX- fire safety- and TA-LUFT-approved. The pneumatic motorisation is available in double and spring-return with numerous options.

AVAILABLE MODELS

DN 15 to DN 100 diameters.
DN 65 to DN 100 diameters.
PN40 RF flange connection.
Double and spring-return actuators.

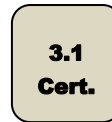

LIMITS OF USE

Fluid pressure: PS	40 bar (20°C)
Fluid temperature: WT	-25°C / +220°C
Ambient temperature	- 20°C / +80°C
Motor compressed air	minimum 6 bar / maximum 10 bar

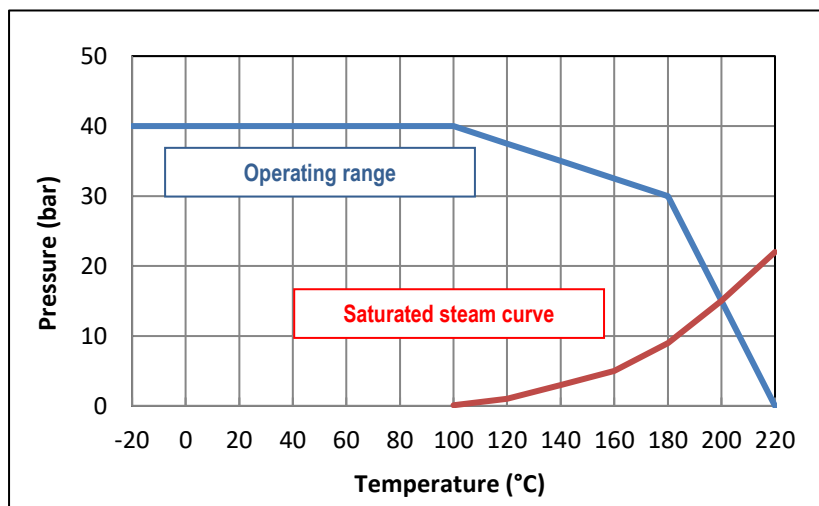

DIRECTIVES AND MANUFACTURING STANDARDS

OBJECT	Standard	ON	OBJECT	Standard
Pressure Equipment Directive 2014/68/EC	DN 15 to DN 25: non soumis		Final test	NKS 12266
	DN 32 to DN 100: category III	TÜV 0035	Material certificate	NKS 10204
Size	EN 12516-1		Motorisation connection	ISO 5211:
Steel grades	EN 1503-1		Motorisation kit	NKS 15081
ATEX Directive	II 2G/D Tx zones 1,2,21 and 22	SIRA 0518	Actuator pilot connection	NAMUR
	EN 13463-1 and 5		Switch box connection	VDI/VDE 3845
Fire safe	API 607/4 - EN10497-5		SIL 3 level (the actuator alone)	NKS 61508

Information given as an indication only, and subject to possible modifications

	SECTORIEL S.A. 45 rue du Ruisseau 38290 SAINT QUENTIN-FALLAVIER – FRANCE Telephone: +33 4 74 94 90 70 - Fax: +33 4 74 94 13 95 www.sectoriel.fr / Email : sectoriel@sectoriel.fr	Pages	1/6
		Ref.	FT710XS+AP-RE ENG
		Rev.	01
		Date	06/2020

710-711XS VALVE WITH AP-RE PNEUMATIC ACTUATOR

CONSTRUCTION

No.	Name	Steel	Stainless steel	No.	Name	Steel	Stainless steel
1	Body	1.0619	1.4408	12	Nut		304 SS
2	Ends	1.0619	1.4408	13	Pointer		304 SS
3*	Seats	PTFE+50% stainless steel		14	Coupling		PVC
4	Ball	CF8M / 316		15	Tie-bolts		304 SS
5	Stem	316 SS		16	Washer		304 SS
6*	Body gasket	Graphite		17	Nuts		304 SS
7*	Washer	PTFE+15%GF		18*	O-ring		FPM
8*	Gasket	Graphite		19	Tab washer		304 SS
9	Spacer	304 SS		20	Anti-static		316 SS
10	B. washer	301 SS		21	Spring		316 SS
11	Lever	304 SS					

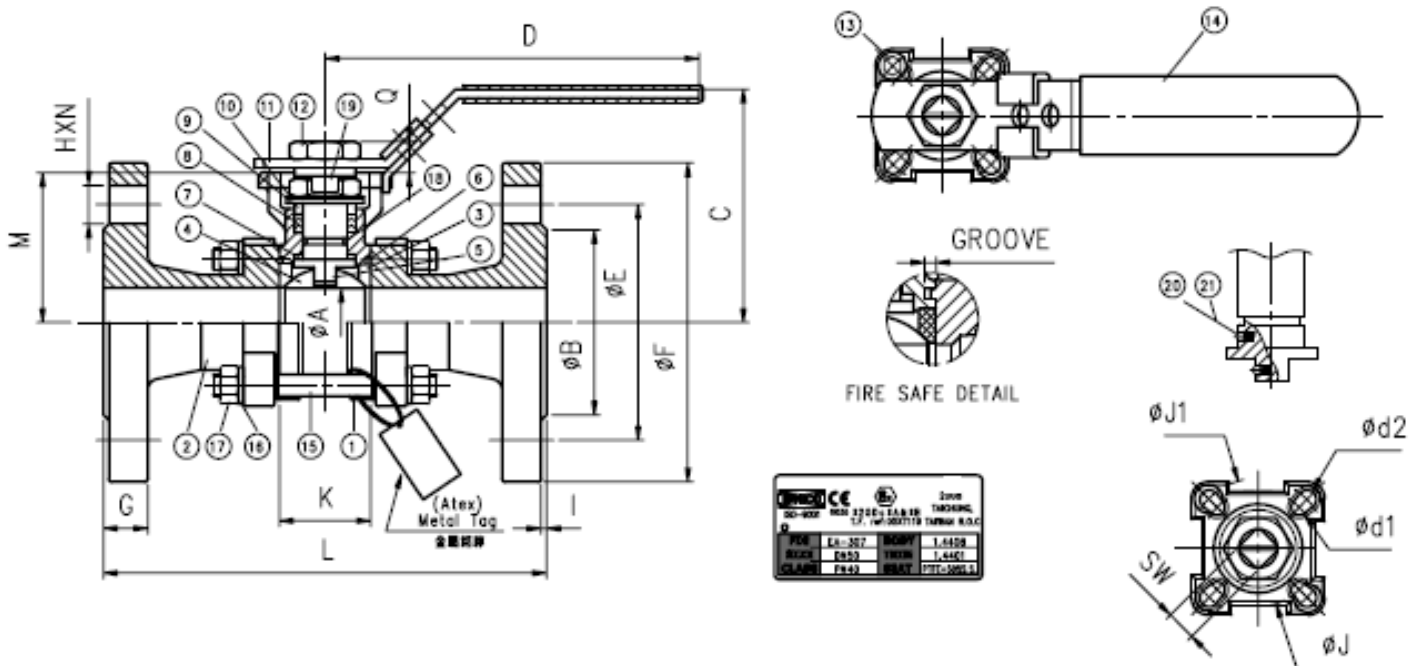

DIMENSIONS (mm)

DN	A	B	C	D	E	F	SW	d1	d2	M	Q	K	L
15	15	45	70,9	125	65	95	9	6	6	42,3	8	25,2	130
20	20	58	73,4	125	75	105	9	6	6	44,8	8	27,2	150
25	25	68	84,1	150	85	115	11	6	7	54	12	33	160
32	32	78	89,3	150	100	140	11	6	7	59,2	12	41,2	180
40	40	88	109,5	165	110	150	14	7	9	73,5	14,8	49,3	200
50	50	102	118,9	165	125	165	14	7	9	82,9	14,8	63,6	230
65	65	122	155	300	145	185	17	9	11	107	17.1	82.1	290
80	80	138	165	335	160	200	17	9	11	117.3	17.1	95.8	310
100	100	162	180	335	190	235	17	9	11	132.3	17.1	117.8	350

Information given as an indication only, and subject to possible modifications

	SECTORIEL S.A. 45 rue du Ruisseau 38290 SAINT QUENTIN-FALLAVIER – FRANCE Telephone: +33 4 74 94 90 70 - Fax: +33 4 74 94 13 95 www.sectoriel.fr / Email : sectoriel@sectoriel.fr	Pages	2/6
		Ref.	FT710XS+AP-RE ENG
		Rev.	01
		Date	06/2020

710-711XS VALVE WITH AP-RE PNEUMATIC ACTUATOR

AP-RE PNEUMATIC MOTORISATION

The ALPHAIR motorisation proposed as standard comprises:

- a safety coefficient of 1.3 minimum compared to the nominal torque of the valve.
- 6 bar air non-lubricated dry motor.
- an upstream / downstream pressure difference $\Delta P=10$ bar max.

Direct mounting.

DN	Double effect	V (litres)	Temps (s)*	Single-effect	V (litres)	Temps (s)*
15	RE 51	0,23	1	RES 51/6	0,23	1
20	RE 51	0,23	1	RES 64/6	0,45	1
25	RE 51	0,23	1	RES 64/6	0,45	1
32	RE 51	0,23	1	RES 76/6	0,61	1
40	RE 64	0,45	1	RES 86/6	0,98	1
50	RE 76	0,61	1	RES 101/6	1,8	2
65	RE 76	0,61	1	RES 101/6	1,80	2
80	RE 86	0,98	1	RES 116/6	2,80	2
100	RE 101	1,80	1	RES 126/6	3,70	2

For any other operating conditions, please contact us.

* indicative time for actuator running empty

OPTIONS

There are many options, so please contact our sales service for more information on these:

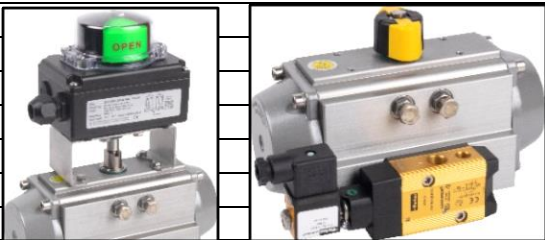
1	actuators dimensioned for a compressed air pressure of 3, 4 or 5 bar	
2	actuator dimensioned for an upstream / downstream pressure difference ΔP greater than 10 bar	
3	actuator with special coating, stainless steel actuator	
4	Actuator for very low (-60°C) or very high (+150°C) ambient temperatures.	
5	Automatic safety valve with a reinforced safety coefficient and closing time < 1s,	
6	special version for ATEX zones	
7	manual override with declutchable gear box	
8	compressed air filter regulator	
9	all types of piloting solenoid valves	
10	all types of switch boxes	
11	all types of positioner	
12	quick exhaust	
13	flow-rate limiters	
14	air lock	
15	ball with decompression hole	

INSTALLATION IN AN ATEX ZONE

For 710 -711XS+AP-RE automatic valves to be installed in ATEX 1, 2, 21 or 22 zones, this has to be specified when ordering. Our services will check of the assembly, the installation of an earthing braid, and will issue an assembly certificate. Our authorised technicians carry out these operations in the workshop. Please contact us.

The special assembly and maintenance instructions for motorised valves in the ATEX zones must be followed.

Information given as an indication only, and subject to possible modifications

	SECTORIEL S.A. 45 rue du Ruisseau 38290 SAINT QUENTIN-FALLAVIER – FRANCE Telephone: +33 4 74 94 90 70 - Fax: +33 4 74 94 13 95 www.sectoriel.fr / Email : sectoriel@sectoriel.fr	Pages	3/6
		Ref.	FT710XS+AP-RE ENG
		Rev.	01
		Date	06/2020

710-711XS VALVE WITH AP-RE PNEUMATIC ACTUATOR

ASSEMBLY AND MAINTAINANCE INSTRUCTIONS

1 - Installation

1.1 - Checks

- Check that the material of the valve body is chemically compatible with the fluid.
- Check that the pressure and service conditions are compatible with the (P, T) diagram of the valve. See § "Service limits"
- Check that the fluid is clean and free of particles. The latter could scratch the ball and damage the seats, hence causing the valve to leak. If need be, install an upstream filter.
- Check that there is no risk of thermal expansion of the fluid, which could damage the seats. In the open position, a hole at the top of the ball balances the pressures between the body cavity and the flow of the fluid. As an option, we recommend a relief hole upstream of the valve for equalising the pressures for fluids such as ammonia, LPG, chlorine, etc.
- Check that the valve is not used for flow or pressure control since it is not intended for this use and there is a risk of premature wear of the seats, in particular in the event of high pressure and/or temperature. For this special application, preferably use our "V-port" version with a V-shaped hole in the ball. Please contact us.
- Check that the valve is not used on a gas which might condense at certain times during the process. In such a case, the pressure within the body cavity could become negative, which could lead to a significant deformation of the seats. Please contact us.
- Static electricity: the valve will be supplied with a ball-stem-body internal electrical continuity tester. If the service conditions require the electrical continuity of the installation, check its earthing.
- If the valve is installed in an explosive zone, you must follow the additional "IMEVMATEX" instructions.

1.2 - Storage before installation

- Follow our general "IMESTOCK" instructions for storage.
- Check that the tie-bolts of the valves were not loosen during transport.

1.3 - Installation

- Before any installation, isolate the piping upstream and downstream, depressurize the piping and bring the installation to ambient temperature. Carefully clean the piping of any particle (foreign body, dust, rust, etc.) or shavings by water rinsing or air blowing.
- For valves with a size above DN50, plan to use a hoist.
- Remove the protective plates from the valve flanges
- Check the cleanliness of the internal surfaces of the valve and if need be, clean them.
- Direction of mounting: the valves do not have a preferred direction of mounting, unless a relief hole was drilled into the ball.
- Check the perfect alignment and the proper support of the pipe installation upstream and downstream of the valve. Alignment defects cause mechanical deformations which can block the valve or lead to leaks at the body gaskets.
- Check that the standards for the valve flanges (PN40 as per 1092-1) and the pipe installation, are the same.
- Select flange gaskets suitable for the fluid and the flange standard for the valve (PN40).

Information given as an indication only, and subject to possible modifications

	SECTORIEL S.A. 45 rue du Ruisseau 38290 SAINT QUENTIN-FALLAVIER – FRANCE Telephone: +33 4 74 94 90 70 - Fax: +33 4 74 94 13 95 www.sectoriel.fr / Email : sectoriel@sectoriel.fr	Pages	4/6
		Ref.	FT710XS+AP-RE ENG
		Rev.	01
		Date	06/2020

710-711XS VALVE WITH AP-RE PNEUMATIC ACTUATOR

- Stock up on hex-head nuts and bolts as shown in the table below:

DN	Screw	Number	Tightening torque (Nm)	DN	Screw	Number	Tightening torque (Nm)
15	M12 x 35	4	35	50	M16 x 55	4	86
20	M12 x 40	4	35	65	M16 x 55	4	86
25	M12 x 45	4	35	80	M16 x 60	8	86
32	M16 x 45	4	86	100	M16 x 60	8	86
40	M16 x 50	4	86				

- Screw the screw through the flanges and apply the torques shown in the table below. Follow a symmetrical tightening cross pattern in order to apply a uniform tightening torque on the gasket seats.
- Hydraulic test of the installation
 - Valves were tested at the factory at 1.5 x WP.
 - If a hydrostatic test is carried out on the installation, do not exceed the authorised pressure.

2 - Service

- If a hot fluid flows across the valve, do not touch the valve surface.
- Always operate the valve slowly and smoothly.
- Opening clockwise, closing anti-clockwise.

3 - Servicing

3.1 - Frequency of servicing

- The servicing frequency depends upon the use of the valve, of the type of fluid, of its velocity, of its frequency of operation, of the cycles of rise and fall in pressure and temperature.
- Before any intervention, isolate the upstream and downstream pipe installation using the valves provided for this purpose. Depressurize the pipe installation and bring it to ambient temperature.
- If the lever has to be removed, do that before disassembling the body.
- To remove the central body, unscrew the tie-bolts symmetrically. Then gently remove the central part avoiding to drop the ball.
- To remove the ball from the body, turn the stem by a quarter turn.

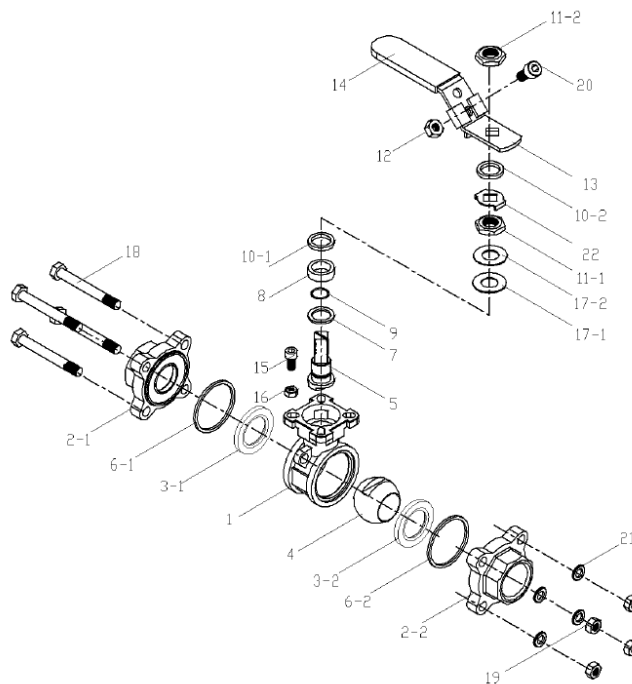

Information given as an indication only, and subject to possible modifications

	SECTORIEL S.A. 45 rue du Ruisseau 38290 SAINT QUENTIN-FALLAVIER – FRANCE Telephone: +33 4 74 94 90 70 - Fax: +33 4 74 94 13 95 www.sectoriel.fr / Email : sectoriel@sectoriel.fr	Pages	5/6
		Ref.	FT710XS+AP-RE ENG
		Rev.	01
		Date	06/2020

710-711XS VALVE WITH AP-RE PNEUMATIC ACTUATOR

3.2 - Inspecting the state of the valve and possible repair

- Check the state of the ball (Item 4): it has to be clean and unscratched. If the cleaning or polishing is not possible, replace it (see the § on spare parts).
- Check the state of the seats (3.1 and 3.2): they must not be deformed, nor scratched, nor worn, or dirty. Otherwise, replace them with parts from the gasket kit.
- Check the state of the packing gland (7.8 and 9): no leak should be found at the stem and the rings should not be excessively worn. If need be, replace the gaskets.
- Check the state of the body gaskets (6.1 and 6.2). Replace them if necessary.
- Reassemble the different parts of the valve, following the tightening torques shown in the table below.
- Check that the stem manoeuvring is smooth. Perform about ten manoeuvres.

TABLE OF THE TIGHTENING TORQUES OF THE TIE-BOLTS AND OF THE LEVER NUT

DN	Tie-bolts	Torque (Nm)	Lever nut (Nm)
15	M6	190	4
20	M8	220	4
25	M8	250	4.5
32	M10	310	4.5
40	M10	410	5.5
50	M10	410	5.5
65	M12	1000	7
80	M16	1220	7
100	M16	1430	7

SPARE PARTS

DN	Gasket kit	Ball	V30° ball	V60° ball	Tie-bolt kit	Lever
Reference mark	6-7-8-18	4	4	4	15-16-17	11
15	982872	980032	980042	980052	982832	982802
20	982873	980033	980043	980053	982833	982802
25	982874	980034	980044	980054	982834	982804
32	982875	980035	980045	980055	982835	982804
40	982876	980036	980046	980056	982836	982806
50	982877	980037	980047	980057	982837	982806
65	982878	Please contact us.	Please contact us.	Please contact us.	982838	982808
80	982879	Please contact us.	Please contact us.	Please contact us.	Please contact us.	982808
100	982880	Please contact us.	Please contact us.	Please contact us.	Please contact us.	982808

Information given as an indication only, and subject to possible modifications

	SECTORIEL S.A. 45 rue du Ruisseau 38290 SAINT QUENTIN-FALLAVIER – FRANCE Telephone: +33 4 74 94 90 70 - Fax: +33 4 74 94 13 95 www.sectoriel.fr / Email : sectoriel@sectoriel.fr	Pages	6/6
		Ref.	FT710XS+AP-RE ENG
		Rev.	01
		Date	06/2020

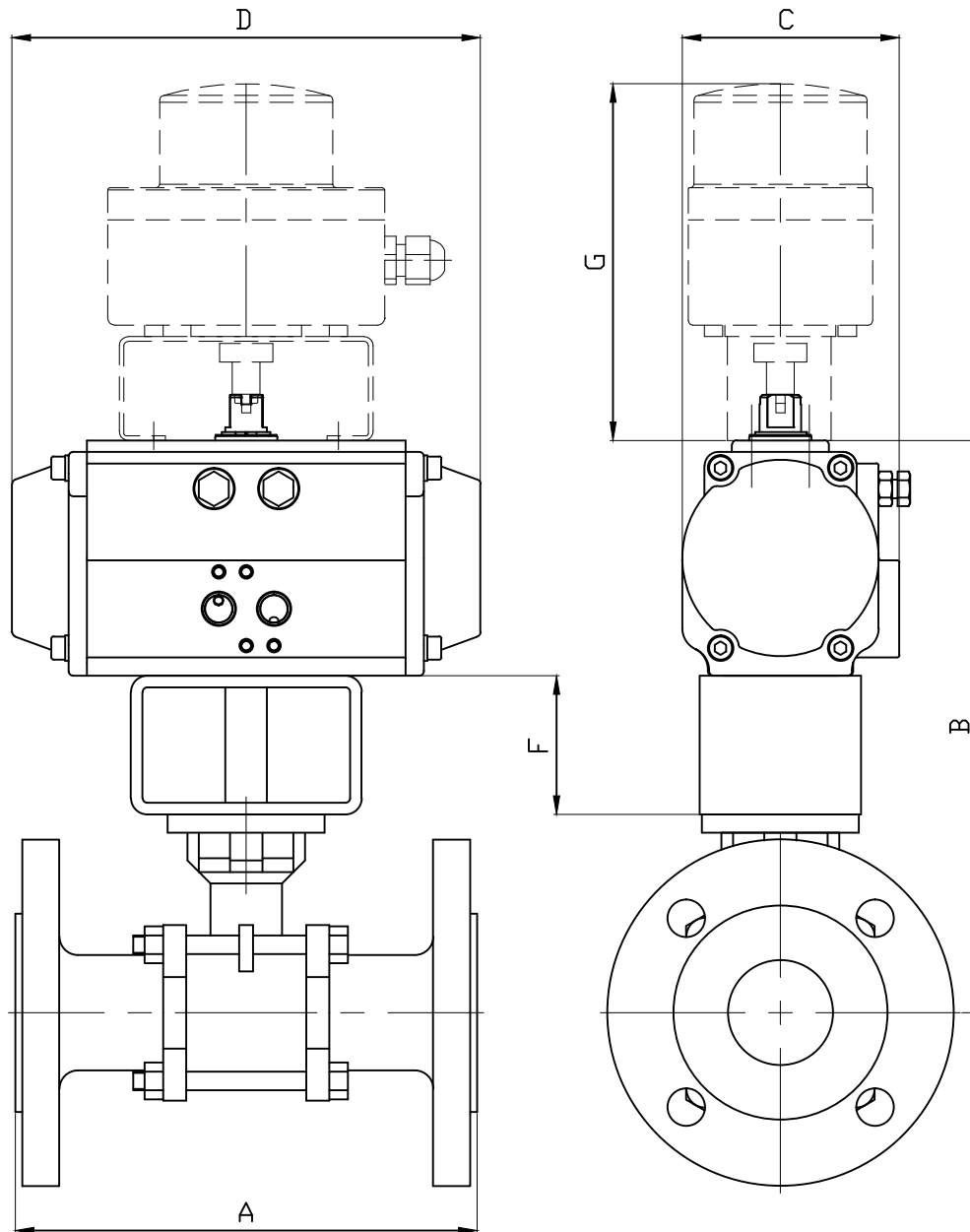

DN	DN15		DN20		DN25		DN32		DN40		DN50		DN65		DN80		DN100	
ALPHAIR	RES1	RESS1	RES1	RES64	RES1	RES64	RES1	RES76	RE64	RES86	RE76	RES101	RE76	RES101	RE86	RES116	RE101	RES126
A	130		150		160		180		200		230		290		310		350	
B	171.3	173.8	190.8	123	140	128.2	221.2	159.5	245.5	184.9	209.9	209	234	229.3	262.8	259.3	289.8	
C	75	75	75	86	75	94	86	104	94	120	94	120	104	134	120	146		
D	138	138	138	155	138	203	155	239	203	261	203	261	239	304	261	333		
F	60	60	-	-	60	-	60	-	60	-	-	-	-	-	-	-	-	-
G	154.5	154.5	154.5	154.5	154.5	154.5	154.5	154.5	154.5	154.5	154.5	154.5	154.5	154.5	164.5	154.5	164.5	
KG	3.9	4	4.77	5.49	5.3	6	8.17	10.9	9.46	13.23	14.24	18	21.6	25.42	29.4	36.4	43	47.23

Informations données à titre indicatif et sous réserve de modifications éventuelles
data subject to alteration

Ech: /	Date :16/07/2019	Dessiné par : E.D.	Tolérances générales : +/- 0.2	Modifications	Date	REV.
ROBINET A TOURNANT SPHERIQUE 710-711XS/BALL VALVE 710-711XS + ACTIONNEUR ALPHAIR RE/PNEUMATIC ACTUATOR ALPHAIR RE + BFC/LIMIT SWITCH BOX				Matière :		
				Poids <Kg> :		
				Traitement : SANS		
				45, Rue du Ruisseau		
38297 SAINT QUENTIN FALLAVIER				Plan n° Ens 1368		



RE SERIES

**PNEUMATIC ACTUATORS
WITH EXTERNAL ADJUSTMENT**

ROTATION 90°



English edition



Alphaair

Distributed in FRANCE by
SECTORIEL

2017

ALPHAIR PNEUMATIC ACTUATORS EXTERNAL ADJUSTMENT New "RE" SERIES

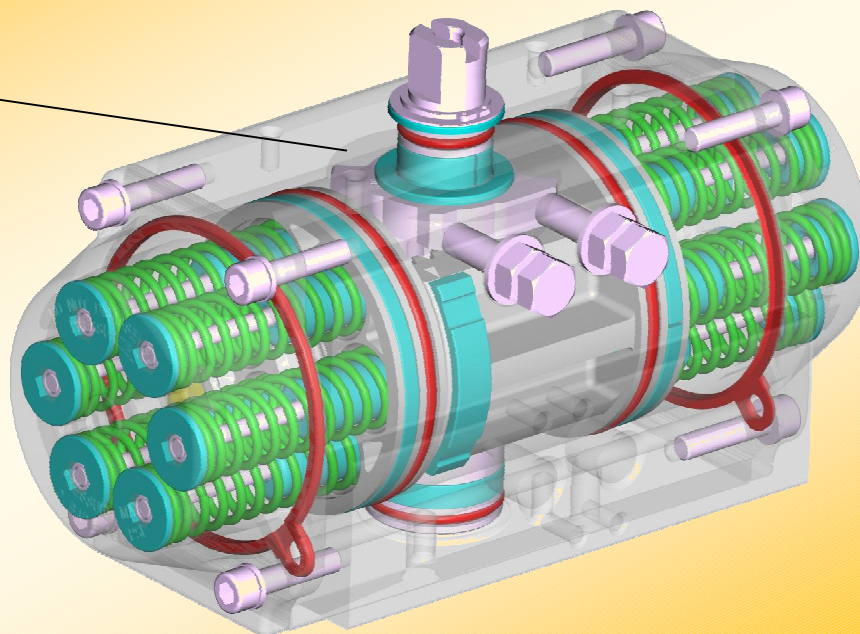
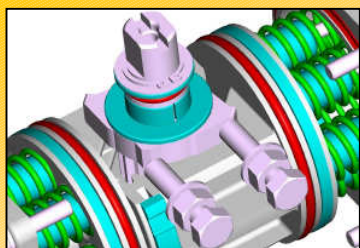

The new series of ALPHAIR Pneumatic Actuators with special "External Adjustment" system meets every quality and precision requirement.

The new "External Adjustment" system guarantees maximum precision on rotation adjusting, for normal and heavy conditions, in any application field.

Suitable for every requirement, ALPHAIR Pneumatic Actuators with special "External Adjustment" system are carefully designed for maximum torque rating and maximum lifetime.

More compact, heavy and reliable, ALPHAIR Pneumatic Actuators with special "External Adjustment" system can be easily assembled on every kind of valve.

STANDARD VERSION FEATURES

- **EN AW 6063 extruded aluminium Body**, inside surface finishing Ra= 0,4-0,6. 25 µ Hard Anodizing.
- **EN AB 46100 die-cast aluminium alloy Pistons**, 15 micron Anodizing.
- **EN AB 46100 die-cast aluminium alloy Covers**, painted with 60-80 µ polyester powder.
- **Carbon steel Shaft**, 20 µ nickel-plated. Stainless Steel AISI 304 (A2) or AISI 316 (A4) as Optional.
- **External adjusting gear, made of Stainless Steel AISI 316 (A4).**
- **AISI 316 (A4) Stainless Steel Screws.**
- **NBR nitrile rubber seals.** FPM/FKM or SILICONE on request.
- Acetalic resin + 20% PTFE bearings, for low friction, easily replaceable for maintenance. PA66 or LEXAN on request.
- Pre-compressed Spring Cartridges, easily replaceable for maintenance, 60-80 micron polyester painted.
- High performances Syntetic Grease as standard grease. Special grease supplied for HIGH/LOW/VERY LOW temperatures.
- Several special protections available for chemical, pharmaceutical, food and industrial environments.
- Rotation adjustment $\pm 5^\circ$ in both opening and closing position. Assembly precision $\pm 1^\circ$, made by electronic devices.
- Double lower drilling for valve fastening and centering, according to ISO 5211-DIN 3337 Standards.
- Double square lower female shaft key (starlike), according to ISO 5211-DIN 3337 Standards for assembly on valves with square key on line (0°) and diagonal key (45°).
- Solenoid connections according to NAMUR VDI\VDE-3845 Standards.
- Top drilling for accessories fastening, and upper shaft end according to NAMUR VDI\VDE-3845 Standards.
- Position indicator on request, enabling switch-box assembly on top.
- Aluminium adhesive nameplates, with progressive serial number punched.
- Lubrication carried out by the manufacturer, guaranteed for min. 1.000.000 operations.
- Running test and 100% seal test carried out with electronic equipment and certification of every individual product.
- Standard execution for temperatures from -20°C to $+80^\circ\text{C}$ (optional, special execution for extreme temperatures).
- Conformity for use in explosive environment; Ex II 2 GD "c" protection type.
- According to EN 15714-3 design and manufacture standard requirements.

FEEDING	TEMPERATURE RANGE	SUPPLY PRESSURE	ROT. ADJUSTMENT
Dry or lubricated 50 um filtered compressed air	Standard $-20^\circ +80^\circ\text{C}$ ($-4 +175^\circ\text{F}$) HIGH Temperature $-20^\circ +150^\circ\text{C}$ ($-4 +300^\circ\text{F}$) LOW Temperature $-40^\circ +80^\circ\text{C}$ ($-40 +175^\circ\text{F}$) VERY LOW Temperature $-60^\circ +80^\circ\text{C}$ ($-76 +175^\circ\text{F}$)	8 bar/120 psi Continuous working - 10 bar/142 psi MAXIMUM	$\pm 5^\circ$ in both OPENING and CLOSING position

DIMENSIONS – European Sizes in millimetres

VDI/VDE-3854

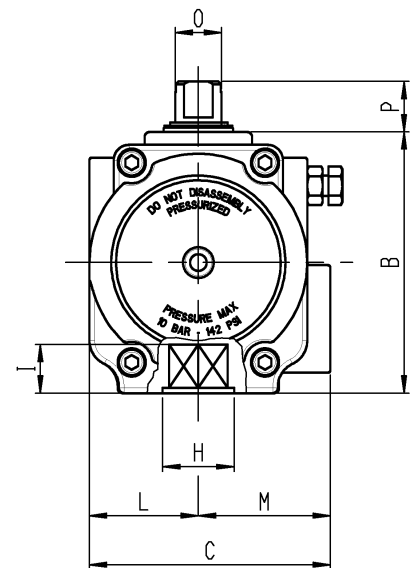
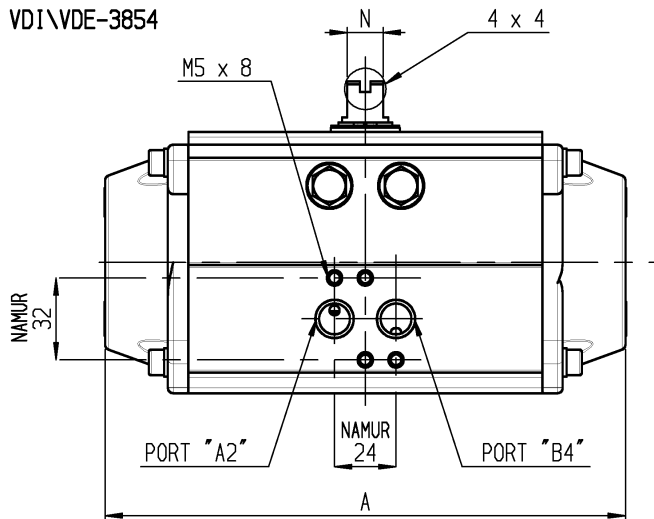

VDI/VDE-3854

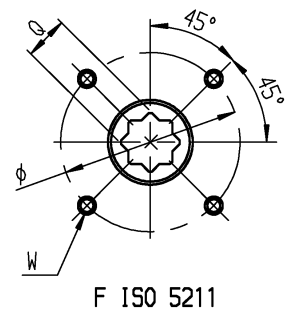
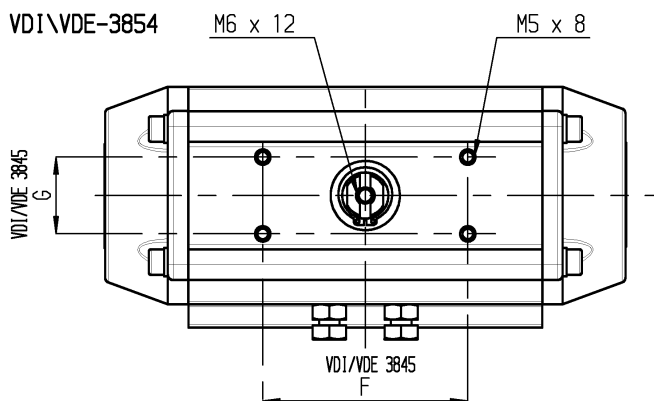

POSITION	TYPE															
	RE 043	RE 051	RE 064	RE 076	RE 086	RE 101	RE 116	RE 126	RE 146	RE 161	RE 181	RE 201	RE 241	RE 271	RE 331	RE 421
A	141	138	155	203	239	261	304	333	398	424	482	528	604	684	850	940
B	62	69	86	102	112	127	145,5	157,5	177	196	220	246	298	332	414	542
C	63,5	75	86	94	104	120	133,5	144,5	164,5	182	203,5	222	300	352	400	528
VDI/VDE 3845 F x G	80 x 30 50 x 25	80 x 30					80 x 30 130 x 30			130 x 30						200 x 50
L	27	33,5	38	42,5	49	55	63,5	69,5	80,5	89	99,5	110	150	176	190	234
M	36,5	41,5	48	51,5	55	65	70	75	84	93	104	112	150	176	210	294
Port A Port B DIN 259	1/8" GAS-NPT			1/4" GAS-NPT									1/2" GAS-NPT			
N x O	8 x 12			14 x 18			27 x 36			32 x 42		42 x 60	55 x 80			
P	20						30			50						80
Q x I	9 x 10 11 x 13	9 x 10 11 x 13	9 x 10 11 x 13 14 x 16	11 x 13 14 x 16 17 x 20	14 x 16 17 x 20	14 x 16 17 x 20 22 x 25	17 x 20 22 x 25	17 x 20 22 x 25 27 x 29	22 x 25 27 x 29	22 x 25 27 x 29	27 x 29 36 x 39	27 x 29 36 x 39	36 x 39 46 x 50	36 x 39 46 x 50	*46 x 50 55 x 60	*55 x 60 75 x 80
F ISO 5211	F04	F04	F05/07	F05/07	F05/07	F07/10	F07/10	F07/10	F10/12	F10/12	F10/12	F14	F14	F16	F16/25	F25/30
Optional	F03/05	F03/05	F3/5/7			F5/7/10		F7/10/12			F14	F10/12	F(12)/16	F(12)/16		F(16)
Volume DE	0,180 lt	0,300 lt	0,500 lt	0,700 lt	1,000 lt	1,800 l	2,900 lt	3,700 lt	6,100 lt	7,900 lt	11,2 lt	14,4 lt	19,2 lt	32,2 lt	62,8 lt	131 lt
Volume SE	0,072 lt	0,120 lt	0,200 lt	0,280 lt	0,400 lt	0,720 l	1,160 lt	1,480 lt	2,440 lt	3,160 lt	4,480 lt	5,760 lt	7,680 lt	12,9 lt	25,1 lt	52,4 lt

POSITION	F ISO 5211											
	F03	F04	F03/05	F05	F05/07	F5/7/10	F07/10	F10/12	F14	F16	F25	F30
Ø (W)	Ø 36 (M5x8)	Ø 42 (M5x8)	Ø 36 (M5x8) Ø 50 (M6x9)	Ø 50 (M6x9)	Ø 50 (M6x9) Ø 70 (M8x12)	Ø 50 (M6x9) Ø 70 (M8x12) Ø 102 (M10x15)	Ø 70 (M8x12) Ø 102 (M10x15)	Ø 102 (M10x15) Ø 125 (M12x18)	Ø 140 (M16x24)	Ø 165 (M20x30)	Ø 254 (M16x24) N°8 FORI	Ø 298 (M20x35) N°8 FORI
H	25	30	25	35	35 (RE 086=40)	40	55	85 (RE 161=75)	100	130	200	200

CONSTRUCTION PARTS – SPECIFICATIONS

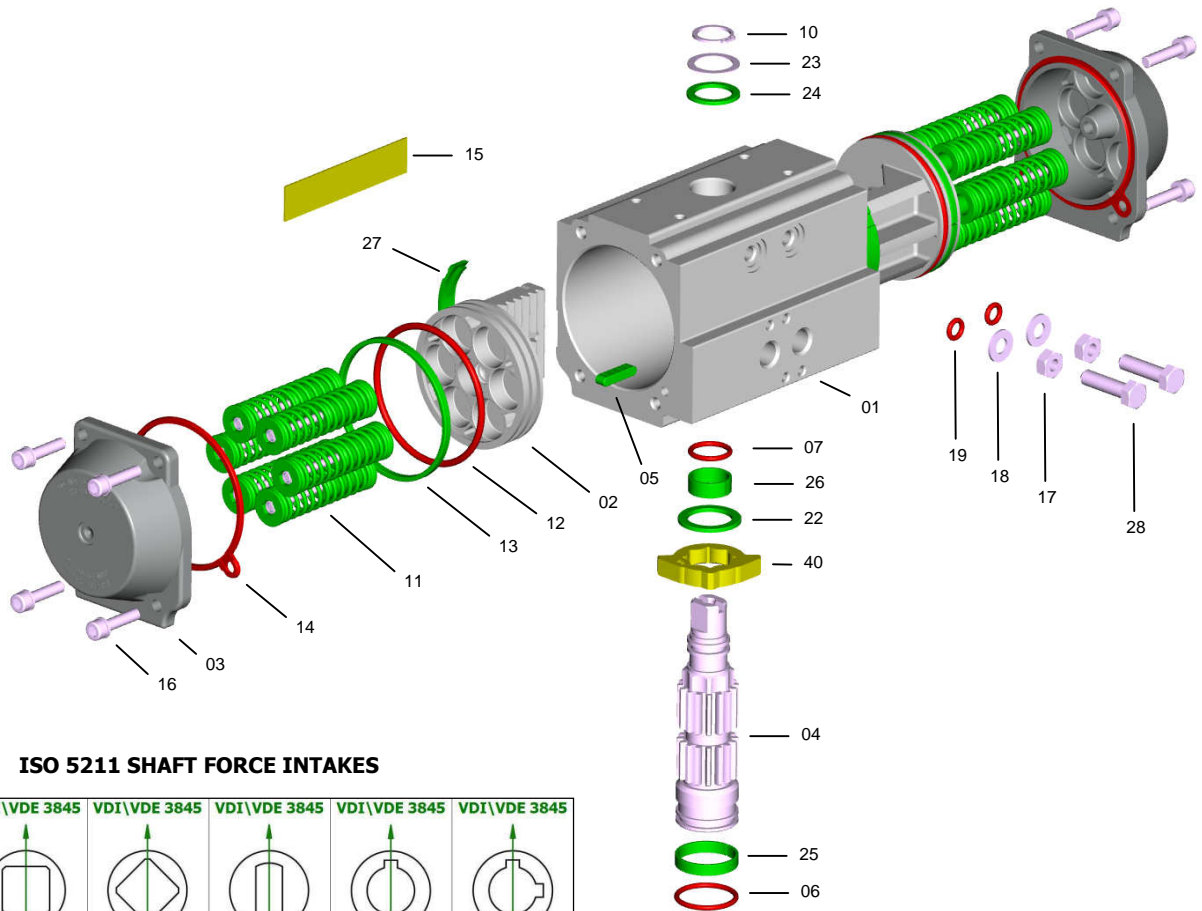

ISO 5211 SHAFT FORCE INTAKES

VDI\ VDE 3845	VDI\ VDE 3845	VDI\ VDE 3845	VDI\ VDE 3845	VDI\ VDE 3845	VDI\ VDE 3845
STANDARD ALPHAIR S = L\ D	L	D	H	V	W

PART	QUANTITY	DESCRIPTION	MATERIAL	SPECIFICATION	PROTECTION
1	1	Body	Extruded aluminium alloy	EN AW 6063 T6	A - N - TF
2	2	Piston	Aluminium alloy	EN AB 46100 T6	A
3	2	Cover	Aluminium alloy	EN AB 46100 T6	N - V - TF
4	1	Shaft	Carbon steel Stainless Steel – optional	ASTM A-105 AISI 304 (A2) AISI 316 (A4)	N
5 *	2	Antiejection key	Acetalic resin – PA66 – PA66 – LEXAN		
6 *	1	Lower shaft O-Ring	NBR – FPM\FKM – Silicone – Silicone		
7 *	1	Upper shaft O-Ring	NBR – FPM\FKM – Silicone – Silicone		
10 *	1	Seeger ring	Carbon steel		N
11	0 ... 12	Spring cartridge	Carbon steel, PA 66, Stainless Steel	C-98	V
12 *	2	Piston O-Ring	NBR – FPM\FKM – Silicone – Silicone		
13 *	2	Piston head bearing	Acetalic resin – PA66 – PA66 – LEXAN		
14 *	2	Cover gasket	NBR – FPM\FKM – Silicone – Silicone		
15	1	Nameplate	Aluminium		
16	4 + 4	Cover fastening screw	Stainless Steel	AISI 304 (A2)	
17	2	Nut	Stainless Steel	AISI 304 (A2)	
18	2	Washer	Stainless Steel	AISI 304 (A2)	
19 *	2	O-Ring	NBR – FPM\FKM – Silicone – Silicone		
22 *	1	Gear antifriction washer	Acetalic resin – PA66 – PA66 – LEXAN		
23 *	1	Shaft thrust washer	Stainless Steel	AISI 304 (A2)	
24 *	1	Shaft antifriction washer	Acetalic resin – PA66 – PA66 – LEXAN		
25 *	1	Lower shaft pilot ring	Acetalic resin – PA66 – PA66 – LEXAN		
26 *	1	Upper shaft pilot ring	Acetalic resin – PA66 – PA66 – LEXAN		
27 *	2	Piston bearing	Acetalic resin – PA66 – PA66 – LEXAN		
28	2	Adjusting gear screw	Stainless Steel	AISI 304 (A2)	
40	1	Adjusting gear	Stainless Steel	AISI 316 (A4)	

* SPARE PARTS SET: Standard, Special HIGH Temperatures, Special LOW Temperatures, Special EXTRA LOW Temperatures

PROTECTIONS

A = Anodizing N = chemical Nickel-plating V = Painting TF = Anodizing+PTFE

COATINGS – MATERIAL TREATMENTS

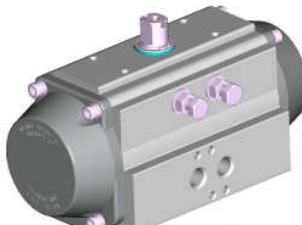
	AV	DESCRIPTION				APPLICATION FIELD	
		Body	Covers	Pistons	Shaft		
	standard	Anodizing	Polyester painting	Anodizing	High phosphorous nickel-plating (12%) opt. AISI 304 (A2) opt. AISI 316 (A4)		- Industry, general use.
	Colour	Gray	Gray	Brown	Polished steel		
	Thickness	25 µ	60/80 µ	15 µ	20 µ		

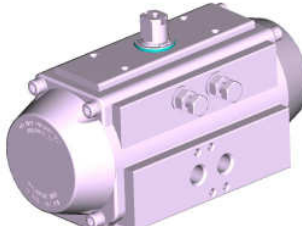
	NN	DESCRIPTION				APPLICATION FIELD	
		Body	Covers	Pistons	Shaft		
	standard	High phosphorous nickel-plating (12%)	High phosphorous nickel-plating (12%)	Anodizing	High phosphorous nickel-plating (12%) opt. AISI 304 (A2) opt. AISI 316 (A4)		- Industry, general use. - Caustic soda. - Detergents. - Low alkaline solutions.
	Colour	Polished steel	Polished steel	Brown	Polished steel		
	Thickness	20 µ	20 µ	15 µ	20 µ		

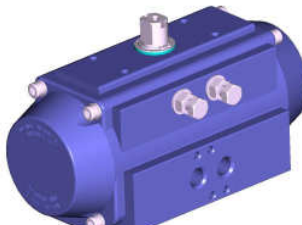
	TF TF	DESCRIPTION				APPLICATION FIELD	
		Body	Covers	Pistons	Shaft		
	standard	Anodizing + PTFE coating	Anodizing + PTFE coating	Anodizing	High phosphorous nickel-plating (12%) opt. AISI 304 (A2) opt. AISI 316 (A4)		- Industry, general use. - Low alkaline and low acid solutions. - Marine environments. - High temperatures.
	Colour	Blue	Blue	Brown	Polished steel		
	Thickness	Anodizing 25 µ PTFE 15 µ	Anodizing 15 µ PTFE 15 µ	15 µ	20 µ		

ANODIZING

Anodizing is an electrolytic process that produces anodic coating on aluminum, called alumine, with high thickness. Alumine is one of the most hard known materials, with resistance values up to 400-600 HV (45-65 HRC); properties and features of Anodizing (alumine thickness 25 micron) are well know and appreciated both for mechanical and chemical resistance.

- **Best friction and corrosion resistance, best surface hardness, good thermic and electrical insulation.**

ELECTROLESS NICKEL-PLATING

Chemical nickel-plating is an electroless coating process that gives nickel layers at extremely constant thickness also on sharp angles, blind-holes, threads and grooves recess. During the process, nickel is combined with phosphor at a percentage of 12% (high-phosphor). The obtained surface hardness is about 400-480 HV (45-55 HRC).

- **Best friction and corrosion resistance, best surface hardness, best external appearance similar to S.S., increased resistance to alcali and detergents in sanitary and food applications.**

POLYESTER PAINTING

Polyester painting is obtained through powder coatings on polarized parts, by means of light differences in electrical potentials. After applications, parts are baked in order to polymerize and let the painting be spread to avoid micro-porosity. The best elasticity can be obtained at 60/80 micron thickness; a satisfactory adhesion can be assured by sandblasting or brushing, and by special degreasing baths of the rough pieces to be treated.

- **Better corrosion resistance, protection against crashes, better external appearance and several available colours, resistance to chemicals.**

ANODIZING + PTFE COATING

As further improvement of the hard anodising treatment on aluminium alloys, protective coatings made of PTFE are used; this material is known for its particular chemical and physical features. On these double treated surfaces, oxide hardness and low roughness (internal slipping parts) is summed to the chemical resistance and the excellent qualities as a thermic barrier of PTFE (external surface, subject to corrosion).

- **Better corrosion resistance, protection against high temperatures and crashes, extreme resistance to chemicals and in marine environments.**

AISI 304 (A2) OR AISI 316 (A4) STAINLESS STEEL SHAFT - OPTIONAL

AISI 304 (A2) and AISI 316 (A4) Stainless Steel shafts, with their great corrosion resistance, are recommended for special applications such as: marine and chemical environments, food and pharmaceutical industry, high temperature applications.



Via Molino Emili, 16 - 25030 MACLODIO (BS) Italy - Tel. +39 030 97 86 61/2- Fax +39 030 97 86 63
www.alphair.it - www.alphapompe.it

Tous droits réservés - Annule et remplace toutes les versions précédentes - Les données sont sujettes à changement sans préavis - Non garantie l'exactitude

COMPANY WITH QUALITY SYSTEM CERTIFIED BY DNV GL = ISO 9001 =					EN UNI 10204 	СЕРТИФИКАТ 
---	---	---	---	---	---	---