

CAST IRON BALL VALVE PN 16 LENGTH DIN 3202

Cast iron ball valve with ISO 5211 mounting pad full bore for heating, cooling, water, watering and irrigation.
2 FKM O Ring and 1 PTFE gasket on stem, PTFE body gasket and PTFE seat.
Compatible with explosive atmosphere, ATEX Zone 1&21 and Zone 2&22 thanks to the antistatic device.
Thanks to the ISO 5211 plate, an actuator can be installed on the valve.



Size : DN15 to DN200
Connection : Flanges PN10/16 RF
Min Temperature : -10°C
Max Temperature : +200°C
Max Pressure : 16 Bars
Specifications : PTFE seat
ISO 5211 mounting pad
Anti blow-out stem
Full bore
Stainless steel ball
ATEX

Materials : Cast iron EN GJL-250

CAST IRON BALL VALVE PN 16 LENGTH DIN 3202

SPECIFICATIONS :

- Full bore
- Anti blow-out stem
- With O ring FKM on stem and PTFE washer
- ISO 5211 mounting pad
- PN10/16 Flanges R.F. up to DN150 and PN16 for DN200 (Threaded holes flanges for DN 125 and 150)
- Solid stainless steel ball up to DN 25, hollow ball from DN 32 to DN 200
- Black painting colour RAL 9004 5-15 microns thickness

USE :

- Heating, water, cooling, watering and irrigation
- Min and max Temperature Ts : - 10°C to + 200°C
- Max Pressure Ps : 16 bars
- **Do not use with steam**
- **Do not use with compressed air**

RANGE :

- Cast iron flanges R.F. with s.s. ball PN10/16 from DN15 to DN150 and PN16 for DN200 **Ref. 507** from DN 15 to DN 200

PRESSURE / TEMPERATURE GRAPH (STEAM EXCLUDED) :

P (bar)

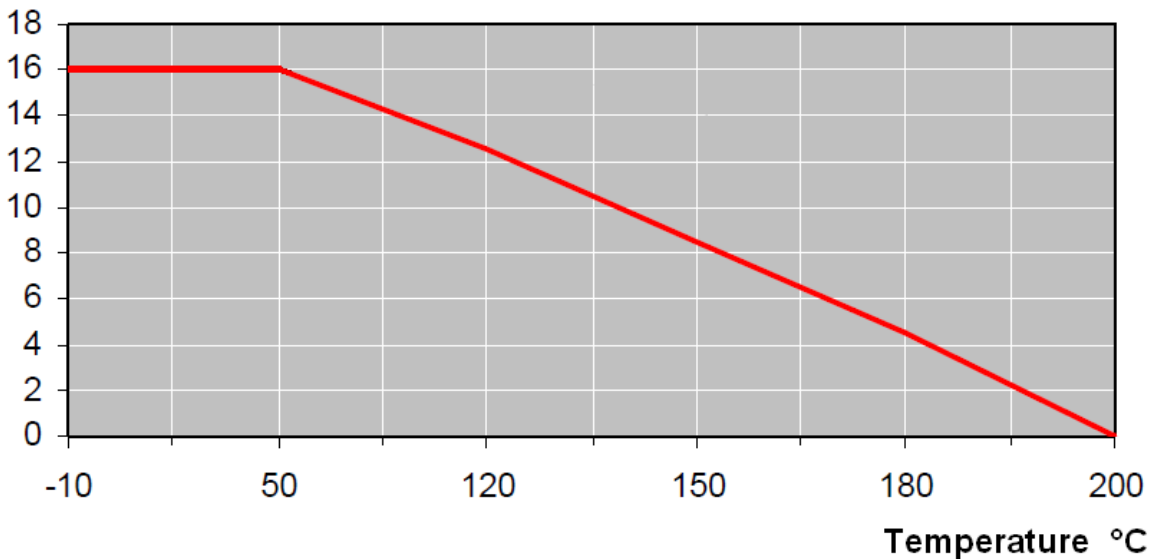

FLOW COEFFICIENT Kvs (in M3/H) :

| DN | 15 | 20 | 25 | 32 | 40 | 50 | 65 | 80 | 100 | 125 | 150 | 200 |
|--------------|------|------|-----|-----|-----|-----|-----|------|------|------|------|-------|
| Kvs (M3 / H) | 37.4 | 74.8 | 105 | 176 | 223 | 416 | 660 | 1200 | 1980 | 3600 | 5040 | 10890 |

TORQUE VALUES (in Nm without safety coefficient) :

| DN | 15 | 20 | 25 | 32 | 40 | 50 | 65 | 80 | 100 | 125 | 150 | 200 |
|---------------|----|----|----|----|----|----|----|----|-----|-----|-----|-----|
| Torque (Nm) | 6 | 6 | 11 | 12 | 26 | 41 | 41 | 71 | 119 | 190 | 220 | 450 |

CAST IRON BALL VALVE PN 16 LENGTH DIN 3202

MATERIALS :

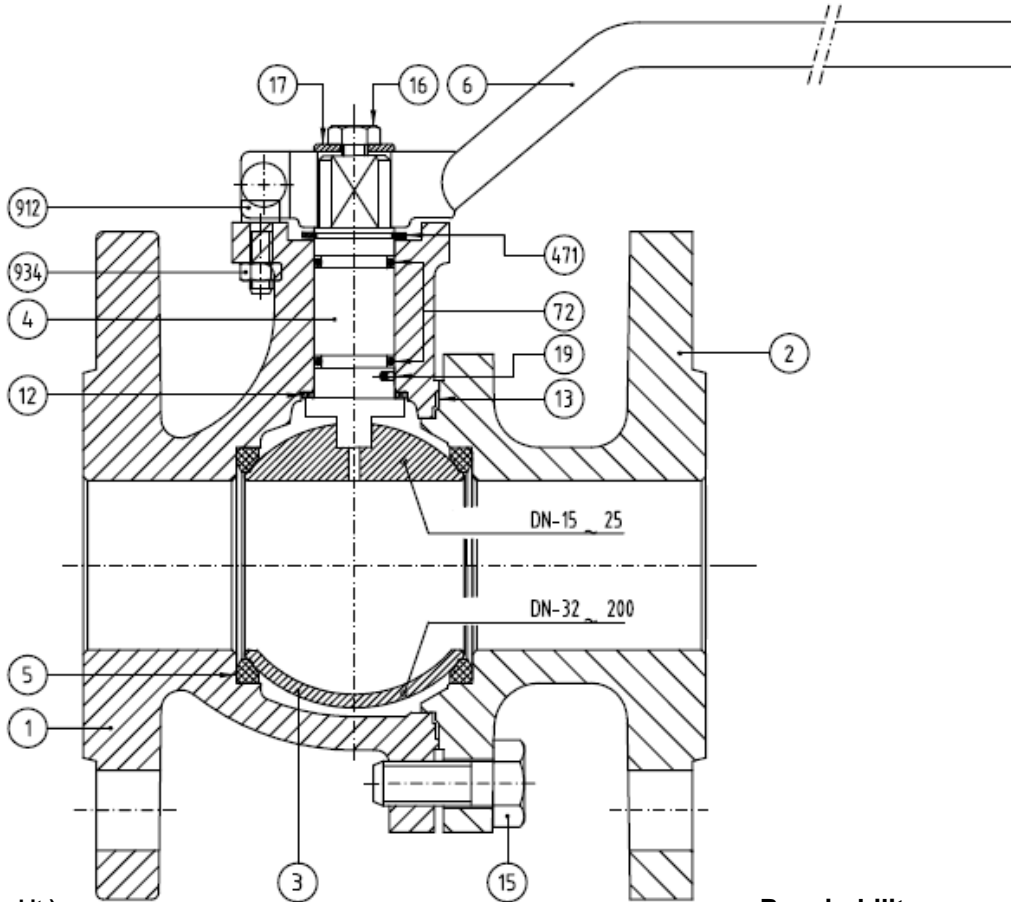

(* : Included in gaskets kit)

Repairability :



| Item | Designation | Materials |
|------|-------------------|----------------------|
| 1 | Body | Cast iron EN GJL-250 |
| 2 | Ends | Cast iron EN GJL-250 |
| 3 | Ball DN15-25 | AISI 303 |
| 3 | Ball DN32-200 | AISI 304 |
| 4 | Stem | |
| 5* | Seat | PTFE |
| 6 | Handle | Steel |
| 12* | Washer | PTFE |
| 13* | Body gasket | PTFE |
| 15 | Body Screw | Steel DIN 933 5.6 |
| 16 | Handle screw | Steel DIN 933 5.6 |
| 17 | Handle Washer | Steel |
| 19 | Antistatic device | Stainless steel |
| 72* | O ring | FKM |
| 471 | Ciclip | Steel DIN 471 |
| 912 | Stop screw | Steel DIN 912 8.8 |
| 934 | Nut | Steel DIN 934.8 |

| Gaskets Kit (item 5, 12, 13 and 72) | |
|-------------------------------------|--------------|
| DN15 | Ref. 9812260 |
| DN20 | Ref. 9812261 |
| DN25 | Ref. 9812262 |
| DN32 | Ref. 9812263 |
| DN40 | Ref. 9812264 |
| DN50 | Ref. 9812265 |
| DN65 | Ref. 9812266 |
| DN80 | Ref. 9812267 |
| DN100 | Ref. 9812268 |
| DN125 | Ref. 9812269 |
| DN150 | Ref. 9812270 |
| DN200 | Ref. 9812271 |

CAST IRON BALL VALVE PN 16 LENGTH DIN 3202

VALVE SIZE (in mm) :

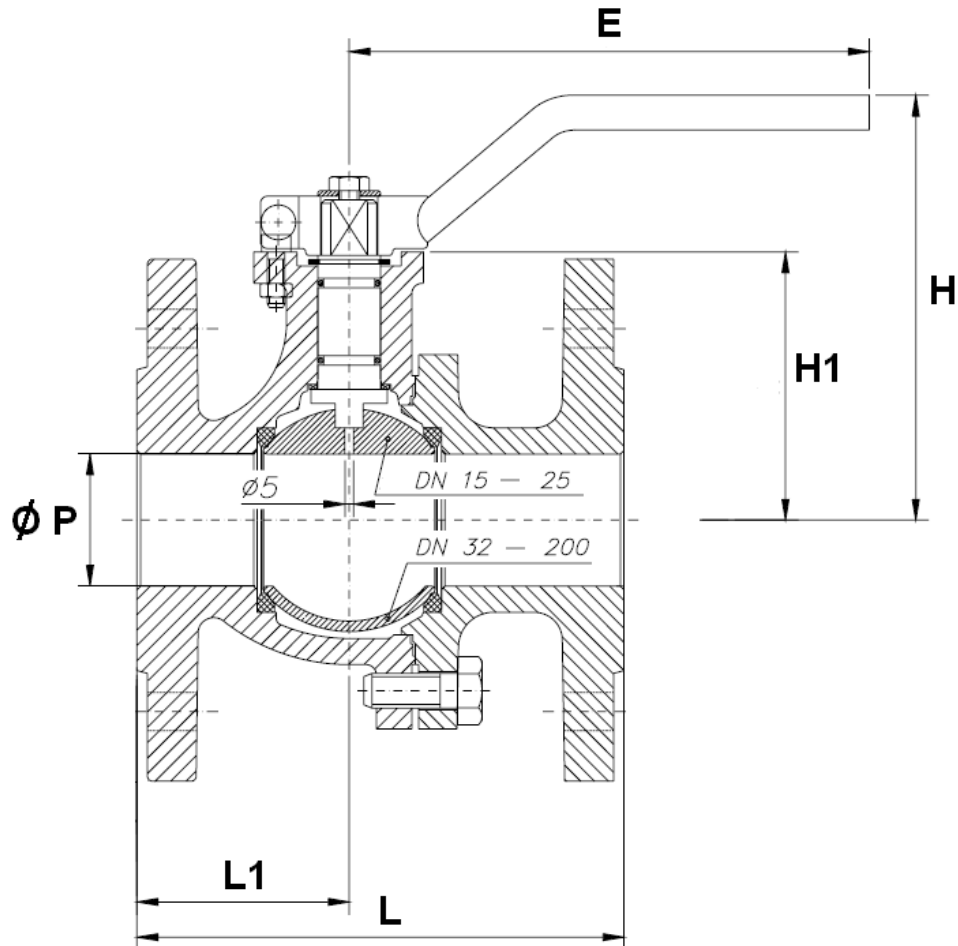

| DN | 15 | 20 | 25 | 32 | 40 | 50 | 65 | 80 | 100 | 125 | 125 | 150 | 150 | 200 |
|-------------|--------|--------|--------|--------|--------|--------|--------|--------|--------|--------|--------|--------|--------|--------|
| Ø P | 13 | 17 | 24 | 31 | 38 | 50 | 65 | 80 | 100 | 125 | 125 | 150 | 150 | 200 |
| L | 115 | 120 | 125 | 130 | 140 | 150 | 170 | 180 | 190 | 200 | 325 | 210 | 350 | 400 |
| L1 | 49 | 55.5 | 51.5 | 53 | 61 | 62 | 81.5 | 79 | 94 | 93 | 120.5 | 100 | 155 | 190 |
| H | 92 | 95.5 | 102.2 | 114.7 | 119 | 127 | 141 | 151.5 | 176.5 | 208 | 208 | 254.5 | 254.5 | 293.5 |
| H1 | 48.5 | 53 | 59.5 | 72 | 77 | 85 | 98 | 108.5 | 134 | 165 | 165 | 190 | 190 | 229 |
| E | 170 | 170 | 170 | 170 | 302.5 | 302.5 | 335 | 335 | 350 | 350 | 350 | 500 | 500 | 500 |
| Weight (Kg) | 2.12 | 2.72 | 3.62 | 5.32 | 6.9 | 9 | 11.68 | 14.68 | 20.23 | 33 | 33.73 | 47.5 | 49.77 | 81.77 |
| Ref. | 507015 | 507020 | 507025 | 507032 | 507040 | 507050 | 507065 | 507080 | 507100 | 507125 | 507126 | 507150 | 507151 | 507200 |

CAST IRON BALL VALVE PN 16 LENGTH DIN 3202

FLANGES SIZE (in mm) :

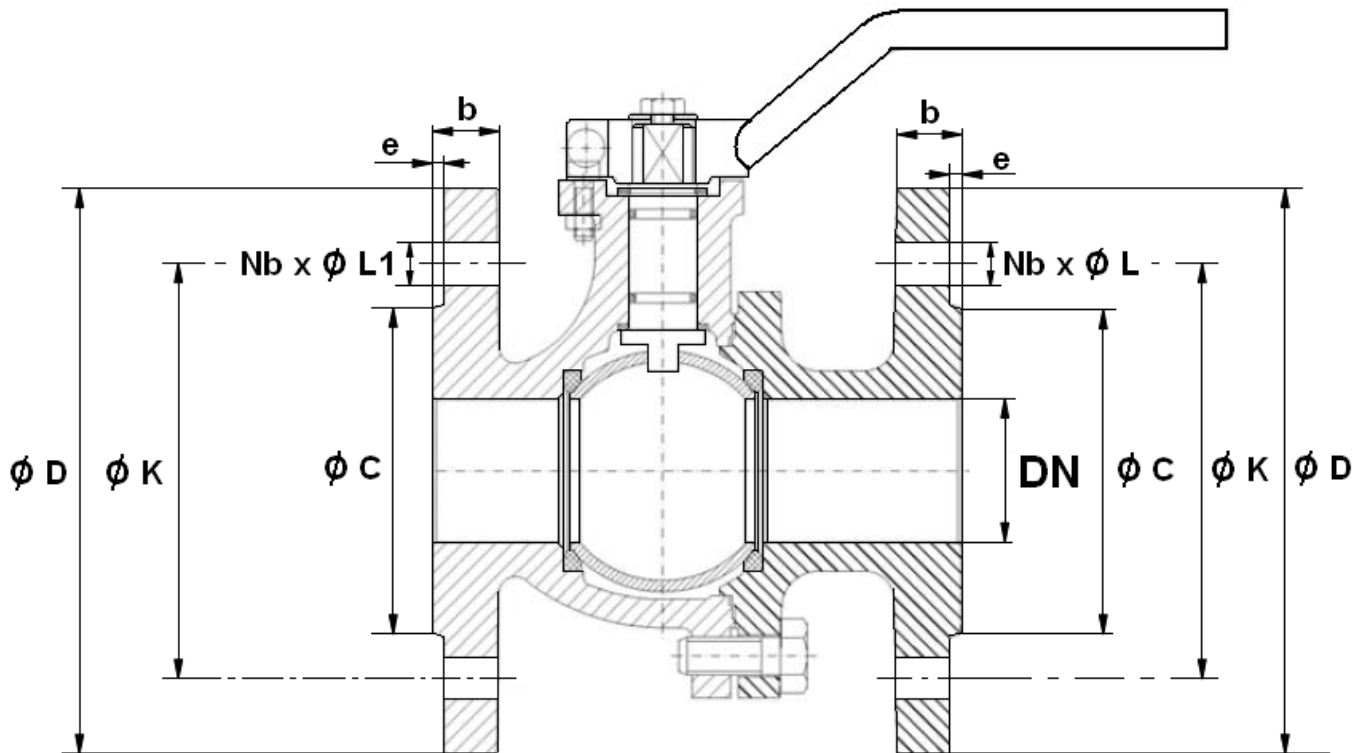

| DN | 15 | 20 | 25 | 32 | 40 | 50 | 65 | 80 | 100 | 125 | 150 | 200 |
|-----------|--------|--------|--------|--------|--------|--------|--------|--------|--------|---------|---------|---------|
| Ø C | 45 | 58 | 68 | 78 | 88 | 102 | 122 | 138 | 158 | 188 | 212 | 268 |
| Ø D | 95 | 105 | 115 | 140 | 150 | 165 | 185 | 200 | 220 | 250 | 285 | 340 |
| Ø K | 65 | 75 | 85 | 100 | 110 | 125 | 145 | 160 | 180 | 210 | 240 | 295 |
| Nb x Ø L | 4 x 14 | 4 x 14 | 4 x 14 | 4 x 18 | 4 x 18 | 4 x 18 | 4 x 18 | 8 x 18 | 8 x 18 | 8 x M16 | 8 x M20 | 12 x 22 |
| Nb x Ø L1 | 4 x 14 | 4 x 14 | 4 x 14 | 4 x 18 | 4 x 18 | 4 x 18 | 4 x 18 | 8 x 18 | 8 x 18 | 8 x M16 | 8 x M20 | 12 x 22 |
| b | 14 | 16 | 16 | 16 | 16 | 18 | 18 | 20 | 20 | 22 | 22 | 24 |
| e | 2 | 2 | 2 | 2 | 3 | 3 | 3 | 3 | 3 | 3 | 3 | 3 |

CAST IRON BALL VALVE PN 16 LENGTH DIN 3202

STEM AND ISO MOUNTING PAD SIZE (in mm) :

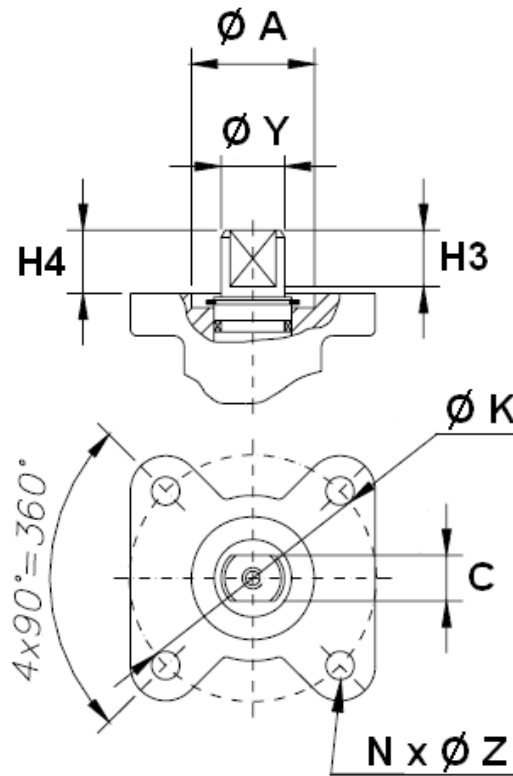

| DN | 15 | 20 | 25 | 32 | 40 | 50 | 65 | 80 | 100 | 125 | 150 | 200 |
|---------|-------|-------|-------|-------|-------|-------|-------|-------|-------|-------|--------|--------|
| Ø K | 42 | 42 | 42 | 42 | 42 | 42 | 70 | 70 | 70 | 70 | 102 | 102 |
| ISO | F04 | F04 | F04 | F04 | F04 | F04 | F07 | F07 | F07 | F07 | F10 | F10 |
| N x Ø Z | 4 x 5 | 4 x 5 | 4 x 5 | 4 x 5 | 4 x 5 | 4 x 5 | 4 x 8 | 4 x 8 | 4 x 8 | 4 x 8 | 4 x 10 | 4 x 10 |
| C | 7 | 7 | 7 | 7 | 12 | 12 | 13 | 13 | 16 | 16 | 20 | 20 |
| Ø Y | 10 | 10 | 10 | 10 | 16 | 16 | 18 | 18 | 22 | 22 | 28 | 28 |
| H3 | 5.5 | 5 | 5 | 5.5 | 16 | 16 | 19 | 19 | 20 | 20 | 27 | 27 |
| H4 | 7.5 | 6 | 6.2 | 6.7 | 15 | 15 | 18 | 18 | 19 | 19.5 | 24.5 | 24.5 |
| Ø A | 19 | 19 | 21 | 21 | 30 | 30 | 35 | 35 | 38 | 38 | 50 | 50 |

CAST IRON BALL VALVE PN 16 LENGTH DIN 3202**STANDARDS :**

- Manufacturer certified ISO 9001 :2015

- DIRECTIVE 2014/68/EU :
 - DN15-100: for gas and liquids of group 1, Article 4, §3 (SEP), no CE marking
 - DN125-150: for liquids of group 1, Article 4, §3 (SEP), no CE marking
 - DN200: for gas and liquids of group 2, Risk Category I, CE marking

- Valve design according to DIN 3357

- Body design according to DIN 3840

- ISO 5211 mounting pad

- Length according to EN 558 series 27 (DIN 3202 F18) excepted for Ref.507125 and 507150

- Length according to EN 558 series 14 (DIN 3202 F4) from DN 125 to 150 for Refs 507125 and 507150

- Flanges R.F according to EN 1092-2 PN10/16

- Marking according to EN 19

- Pressure tests according to EN 12266-1, Rate A

- ATEX Group II Category 2 G/2Dc Zone 1 & 21 Zone 2 &22 (optional marking) according to directive 2014/34/EU

ADVICE : Our opinion and our advice are not guaranteed and SFERACO shall not be liable for the consequences of damages.
The customer must check the right choice of the products with the real service conditions.

CAST IRON BALL VALVE PN 16 LENGTH DIN 3202

INSTALLATION INSTRUCTIONS

GENERAL GUIDELINES :

- Ensure that the valves to be used are appropriate for the conditions of the installation (type of fluid, pressure and temperature).
- Be sure to have enough valves to be able to isolate the sections of piping as well as the appropriate equipment for maintenance and repair.
- Ensure that the valves to be installed are of correct strength to be able to support the capacity of their usage.
- **Installation of all circuits should ensure that their function can be automatically tested on a regular basis (at least two times a year).**

INSTALLATION INSTRUCTIONS :

- **Before installing the valves, clean and remove any objects from the pipes** (in particular bits of sealing and metal) which could obstruct and block the valves.
- **Ensure that both connecting pipes either side of the valve (upstream and downstream) are aligned (if they're not, the valves may not work correctly).**
- **Make sure that the two sections of the pipe (upstream and downstream) match, the valve unit will not absorb any gaps. Any distortions in the pipes may affect the tightness of the connection, the working of the valve and can even cause a rupture.** To be sure, place the kit in position to ensure the assembling will work.
- **If sections of piping do not have their final support in place, they should be temporarily fixed. This is to avoid unnecessary strain on the valve.**
- Tighten the bolts in cross.
- It's recommended to operate the valve (open and close) 1 to 2 times per year
- **For an installation in ATEX area, check the conductivity between the valve, the upstream pipe and the downstream pipe and make sure the pipe is connected to the earth.**

