

2 PIECES FLANGES BALL VALVE CLASS 150 PN20 FIRE SAFE ADLER TYPE FE2 CARBON STEEL

2 pieces forged carbon steel ball valve with flanges Class 150 with full bore for Chemical industries, petrochemical industries, hydraulic installation, heating, water distribution, compressed air.

Ball valve with firesafe certificate ISO 10497 to reduce risks in case of fire.

Fugitive emission according to EN 15848-1 :2003 A Class for an excellent tightness on the stem and to prevent external leakage.

3 PTFE filled with 15% graphite chevrons rings on stem, PTFE seat.

Compatible with explosive atmosphere, ATEX Zone 1&21 and Zone 2&22 thanks to the double antistatic device.

Handling possible with locking device, gearbox, oval handwheel or stem extension.

Thanks to the ISO 5211 plate, an actuator can be installed on the valve.



**NACE
MR01-75**



- Size :** DN15 to DN200 (NPS 1/2" to 8")
- Connection :** Flanged Class 150 PN20 RF
- Min Temperature :** -28°C
- Max Temperature :** +200°C
- Max Pressure :** 20 bars
- Specifications :** Double antistatic device, ATEX
ISO 5211 mounting pad
Anti blow-out stem, full bore
Fugitive emissions ISO 15848-1
Fire safe ISO 10497

Materials : Forged carbon steel ASTM A105N body

2 PIECES FLANGES BALL VALVE CLASS 150 PN20 FIRE SAFE ADLER TYPE FE2 CARBON STEEL

SPECIFICATIONS :

- Full bore
- Anti blow-out stem
- With ISO 5211 mounting pad
- 2 pieces type (Split body)
- Flanges R.F. Class 150 (PN20)
- Double antistatic device
- Fire safe ISO 10497 (ISO-FTmarking)
- Fugitive emissions according to ISO 15848-1 : 2003 Class A
- Double tightness body / end
- With exhaust hole in the ball from DN50 to DN200 (located in the top of the ball to avoid overpressure in it)
- Machining of the seat for pressure relief DN65 to DN200 (respect the flow direction indicated by the arrow)
- 3 PTFE filled with graphite chevrons rings on stem
- Packing with elastic rings
- Forged carbon steel body
- Polyamid epoxy painting blue color RAL5012, 35 µ thickness for carbon steel types

USE :

- Chemical and pharmaceutical industries, petrochemical industries, hydraulic installation, compressed air
- Min and max Temperature Ts : - 28°C to + 200°C
- Max Pressure Ps : 20 bars
- Vacuum : 10⁻⁵ torr
- Compressed air (ambient temperature) : 10 bars up to DN50, 8 bars from DN65 to 100
- Steam : 8 bars up to DN50, 6 bars from DN65 to 100

RANGE :

- Carbon steel body flanges R.F. Class 150 (PN20) **Ref. 766** from DN 15 to DN 200 (NPS 1/2" to 8")
- Possible with gear box IP67 **Ref. 9830260 to 263** from DN 15 to DN 200 (NPS 1/2" to 8")

BOLT TIGHTENING TABLE (FOR FLANGES) (in Nm) :

NPS (")	1/2"	3/4"	1"	1"1/4	1"1/2	2"	2"1/2	3"	4"	5"	6"	8"
DN (mm)	15	20	25	32	40	50	65	80	100	125	150	200
THREADED	M14	M14	M14	M14	M14	M16	M16	M16	M16	M20	M20	M20
Torque (Nm) for carbon steel bolting	135	135	135	135	135	205	205	205	205	400	400	400
Torque (Nm) for stainless steel bolting	84.3	84.3	84.3	84.3	84.3	128	128	128	128	250	250	250

TORQUE VALUES (in Nm without safety coefficient) :

NPS (")	1/2"	3/4"	1"	1"1/4	1"1/2	2"	2"1/2	3"	4"	5"	6"	8"
DN (mm)	15	20	25	32	40	50	65	80	100	125	150	200
Torque (Nm) PN20	5.7	11.2	13.8	16.5	31.5	41	68	80	144	165	380	560

We recommend a safety coefficient of 2 to choose the actuator

2 PIECES FLANGES BALL VALVE CLASS 150 PN20 FIRE SAFE ADLER TYPE FE2 CARBON STEEL

ACCESSORIES AND OPTIONS :

- Locking device **Ref. 9830140 to 9830148** from DN 15 to DN 200 (NPS 1/2" to 8")
- Stainless steel handle **Ref. 9830170 to 9830178** from DN 15 to DN 200 (NPS 1/2" to 8")
- Steel oval handwheel **Ref. 9830271 to 9830272** from DN 15 to DN 32 (NPS 1/2" to 1"1/4)
- Stainless steel oval handwheel
- Stainless steel bolting
- Carbon steel stem extension 100 mm **Ref. 9830273 to 9830280** from DN 15 to DN 200 (NPS 1/2" to 8")
- Stainless steel stem extension 100 mm **Ref. 9830193 to 9830200** from DN 15 to DN 200 (NPS 1/2" to 8")
- Deadman **Ref. 9830160 to 9830165** from DN 15 to DN 50 (NPS 1/2" to 2")
- Dry cleaned oxygen **Ref. 9830150 to 9830155** from DN 15 to DN 200 (NPS 1/2" to 8")
- Standard dry cleaned
- Seat PTFE filled with glass, graphite, stainless steel or metal
- Pocket less seat PTFE or PTFE filled with glass
- Heating jacket carbon or stainless steel
- Specials coated
- Hole in the ball for overpressure device
- Double o ring on stem

ENDS:

- Flanges R.F. Class 150 (PN20)

2 PIECES FLANGES BALL VALVE CLASS 150 PN20 FIRE SAFE ADLER TYPE FE2 CARBON STEEL

MATERIALS :

PACKING GASKETS :

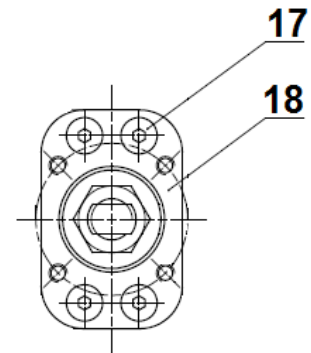
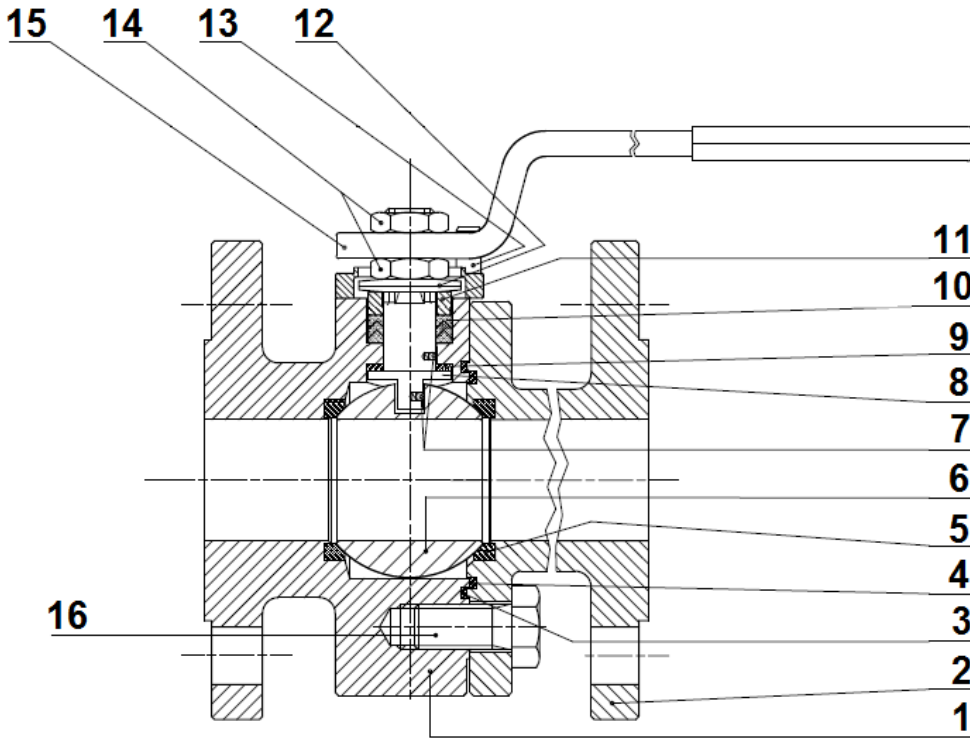

(* : Included in gaskets kit)

Item	Designation	Materials
1	Body	ASTM A105
2	Nipple	
3*	O ring	FKM
4*	Body gasket	PTFE
5*	Seat	PTFE
6	Ball	ASTM A479 304L
7	Double antistatic device	ASTM A479 316
8	Stem	ASTM A479 304L
9*	Stem gasket	PTFE
10*	Chevron packing	PTFE filled with 15% graphite
11	Gland follower	ASTM A479 304
12	Elastic rings	C72 / 50 Cr V4
13	Pin	UNI 3740-8.8 galvanized
14	Nut	UNI 3740-6S galvanized
15	Handle	AISI 1010 galvanized
16	Screw	UNI 3740-8.8 galvanized
17	ISO 5211 screw (DN 15-80)	UNI 3740-10.9 galvanized
18	ISO 5211 mounting pad (DN15-80)	ASTM A351 CF8M

2 PIECES FLANGES BALL VALVE CLASS 150 PN20 FIRE SAFE ADLER TYPE FE2 CARBON STEEL

MATERIALS GEAR BOX :

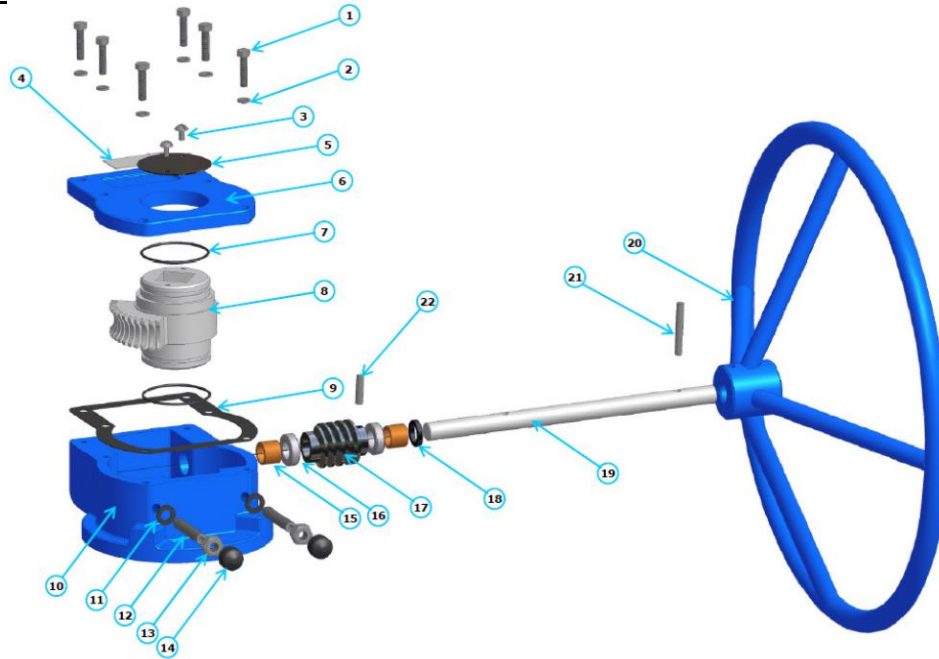

Item	Designation	Materials Ref. 9830260 to 9830263
1	Box screw	DIN 933 class 8.8
2	Washer	C72
3	Indicator screw	DIN 86 class A2
4	ID plate	Steel S235 JR
5	Indicator	Steel S235 JR
6	Cover	Ductile iron EN GJS-400-15
7	O ring	NBR 70 Shore A
8	Wheel	Ductile iron EN GJS-500-7
9	Cover gasket	SL509AT
10	Box	Ductile iron EN GJS-400-15
11	Gasket	NBR 70 Shore A
12	Adjusting bolt	DIN 915 class 12.9
13	Nut	DIN 934 class 8G
14	Bolt cap	NBR 70 Shore A
15	Bushing	G Cu Sn10
16	Axial ball bearing	-
17	Worm	C45 + NiP
18	Gasket	NBR 70 Shore A
19	Input shaft	C45 + NiP
20	Handwheel	Steel S235 JR
21	Dowell pin	DIN 7 Class A2
22	Dowell pin	DIN 7 Class A2

2 PIECES FLANGES BALL VALVE CLASS 150 PN20 FIRE SAFE ADLER TYPE FE2 CARBON STEEL

VALVES SIZE DN 15 – 80 (NPS 1/2" – 3") (in mm) :

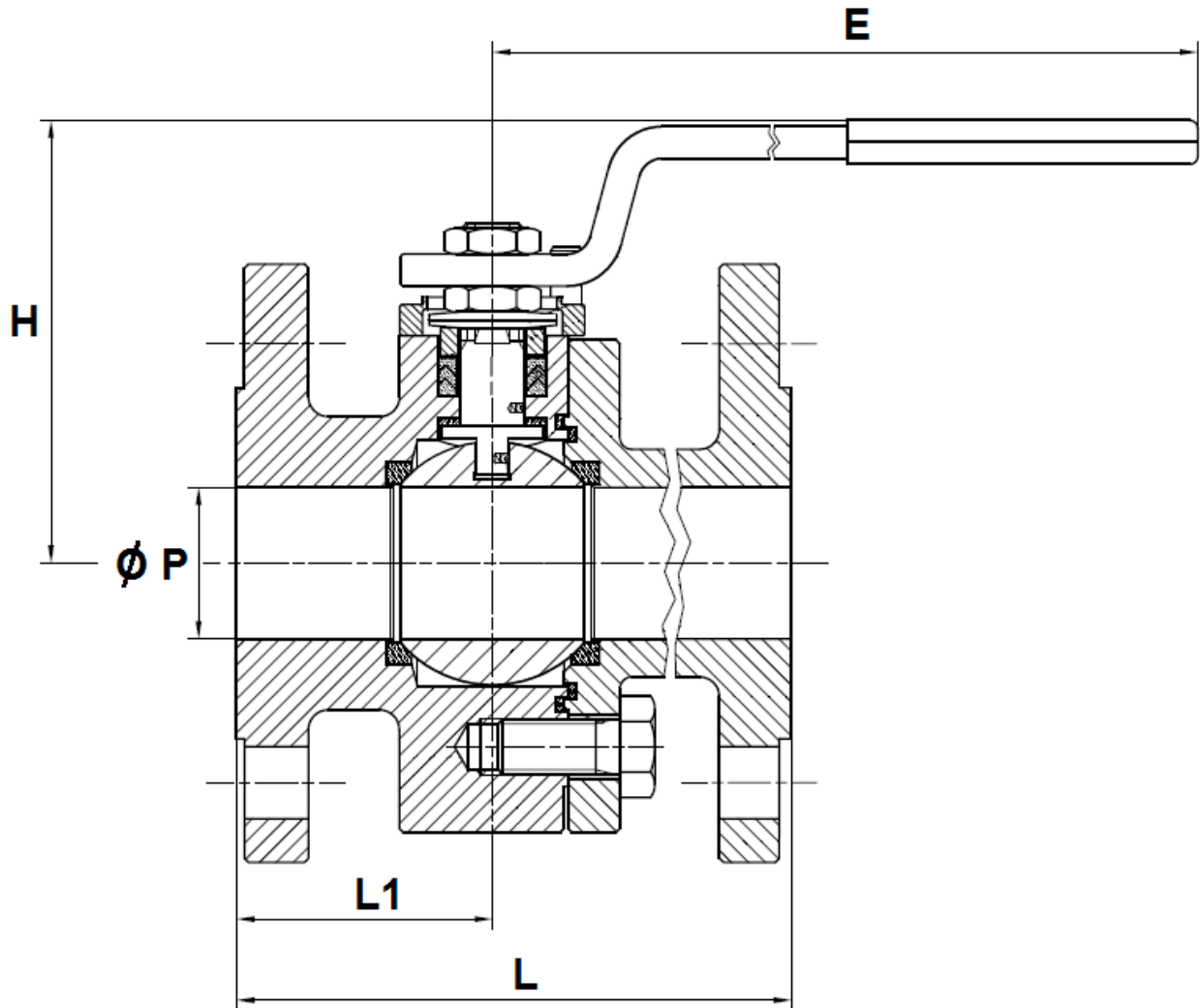

NPS (")	1/2"	3/4"	1"	1"1/4	1"1/2	2"	2"1/2	3"
DN (mm)	15	20	25	32	40	50	65	80
Ø P	15	19	25	30	38	51	64	76
L	108	117	127	140	165	178	190	203
L1	46	48.5	49	52	58	76	72	75
E	145	145	185	185	280	280	370	370
H	86	88	113	119	110	120	144	152
Weight (in Kg)	2.7	3.6	4.5	6.2	9	14.3	21.5	25
Ref.	766015	766020	766025	766032	766040	766050	766065	766080

2 PIECES FLANGES BALL VALVE CLASS 150 PN20 FIRE SAFE ADLER TYPE FE2 CARBON STEEL

VALVES SIZE DN 100 – 200 (NPS 4" – 8") (in mm) :

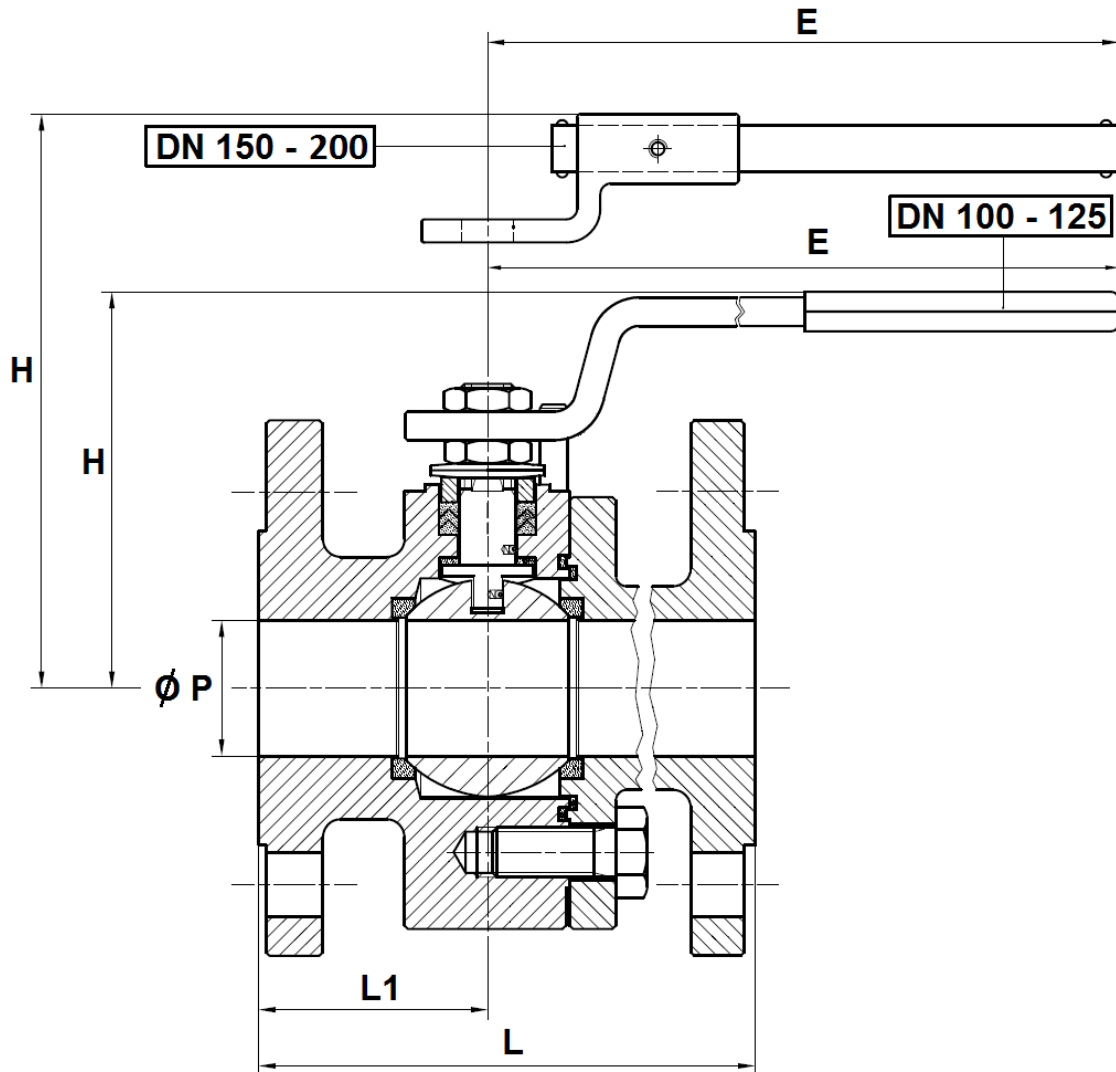

NPS (")	4"	5"	6"	8"
DN (mm)	100	125	150	200
Ø P	101	118	152	203
L	229	254	267	419
L1	77	100	117	155
E	470	650	750	900
H	174	188	256	294
Weight (in Kg)	34	56	91	159
Ref.	766100	766125	766150	766200

2 PIECES FLANGES BALL VALVE CLASS 150 PN20 FIRE SAFE ADLER TYPE FE2 CARBON STEEL

ISO 5211 MOUNTING PAD AND STEM SIZE (in mm) :

DN 15 – 80 (NPS 1/2" - 3")

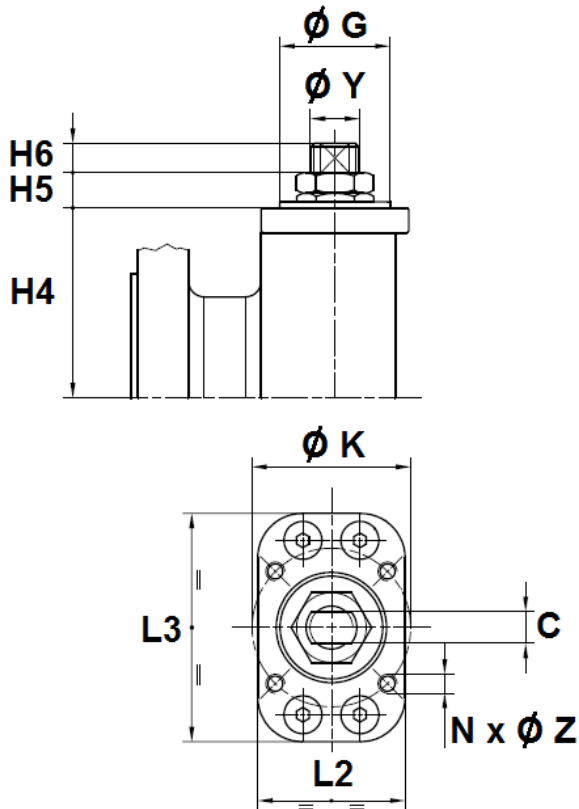

DN 100 – 200 (NPS 4" - 8")

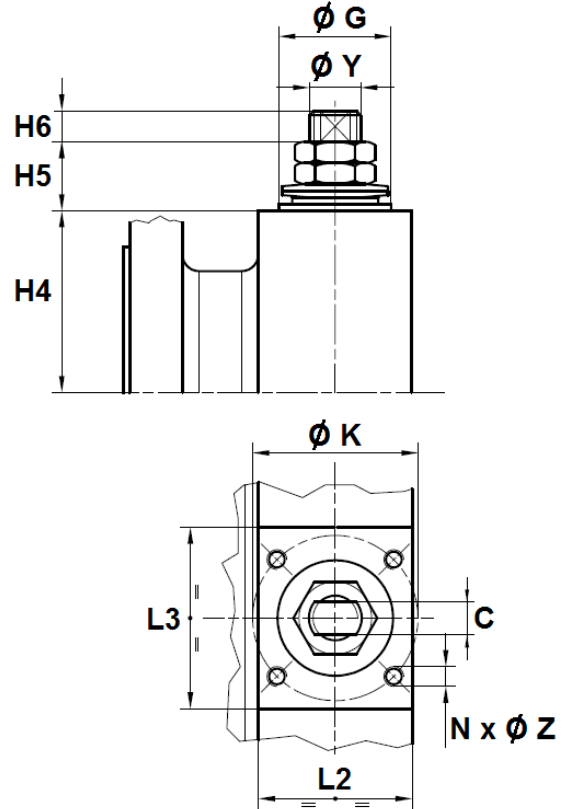

NPS (")	1/2"	3/4"	1"	1"1/4	1"1/2	2"	2"1/2	3"	4"	5"	6"	8"
DN (mm)	15	20	25	32	40	50	65	80	100	125	150	200
H4	32.5	35	41	46.5	55	65	82	86	99.5	113.5	144	183
H5	8	8	17	17	20	20	23	23	26	26	34	36
H6	7	7	10	10	10	10	12	17	17	17	19	20
C	6	6	8	8	10	10	14	14	18	18	28	32
Ø Y	10	10	12	12	16	16	22	22	30	30	42	48
Ø K	36	36	36	36	50	50	70	70	70	102	125	140
ISO	F03	F03	F03	F03	F05	F05	F07	F07	F07	F10	F12	F14
N x Ø Z	4 x M5	4 x M5	4 x M5	4 x M5	4 x M6	4 x M6	4 x M8	4 x M8	4 x M8	4 x M10	4 x M12	4 x M16
Ø G	25	25	25	25	35	35	55	55	55	70	85	100
L2	33	33	33	35	45	53	62	62	64	92	129	176
L3	33	39	43	55	57	64	67	65	70	97	109	123

2 PIECES FLANGES BALL VALVE CLASS 150 PN20 FIRE SAFE ADLER TYPE FE2 CARBON STEEL

FLANGES SIZE (in mm) :

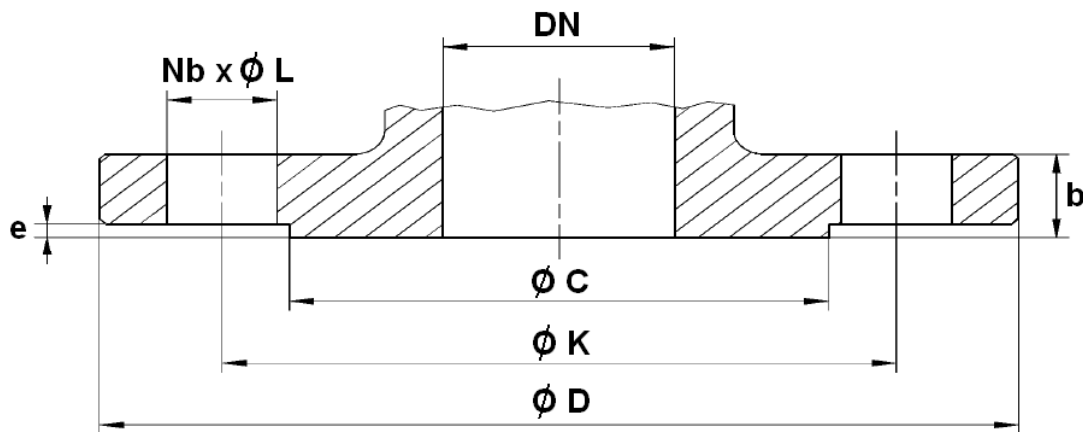

NPS (")	1/2"	3/4"	1"	1"1/4"	1"1/2"	2"	2"1/2"	3"	4"	5"	6"	8"
DN (mm)	15	20	25	32	40	50	65	80	100	125	150	200
Ø C	35.1	43	50.8	63.5	92	104.7	127	157.3	185.7	215.9	269.8	269.8
Ø D	88.9	98.6	108	117.4	127	152.4	177.8	190.5	228.6	254	279.4	342.9
Ø K	60.35	69.9	79.2	88.9	98.6	120.7	139.7	152.4	190.5	215.9	241.3	298.5
Nb x Ø L	4 x 15.8	4 x 15.8	4 x 15.8	4 x 15.8	4 x 15.8	4 x 19.1	4 x 19.1	4 x 19.1	8 x 19.1	8 x 22.4	8 x 22.4	8 x 22.4
b	11.2	12.7	14.3	15.8	17.6	19.1	22.4	23.9	23.9	23.9	25.4	28.5
e	1.6	1.6	1.6	1.6	1.6	1.6	1.6	1.6	1.6	1.6	1.6	1.6

2 PIECES FLANGES BALL VALVE CLASS 150 PN20 FIRE SAFE ADLER TYPE FE2 CARBON STEEL

DEADMAN SIZE (in mm) :

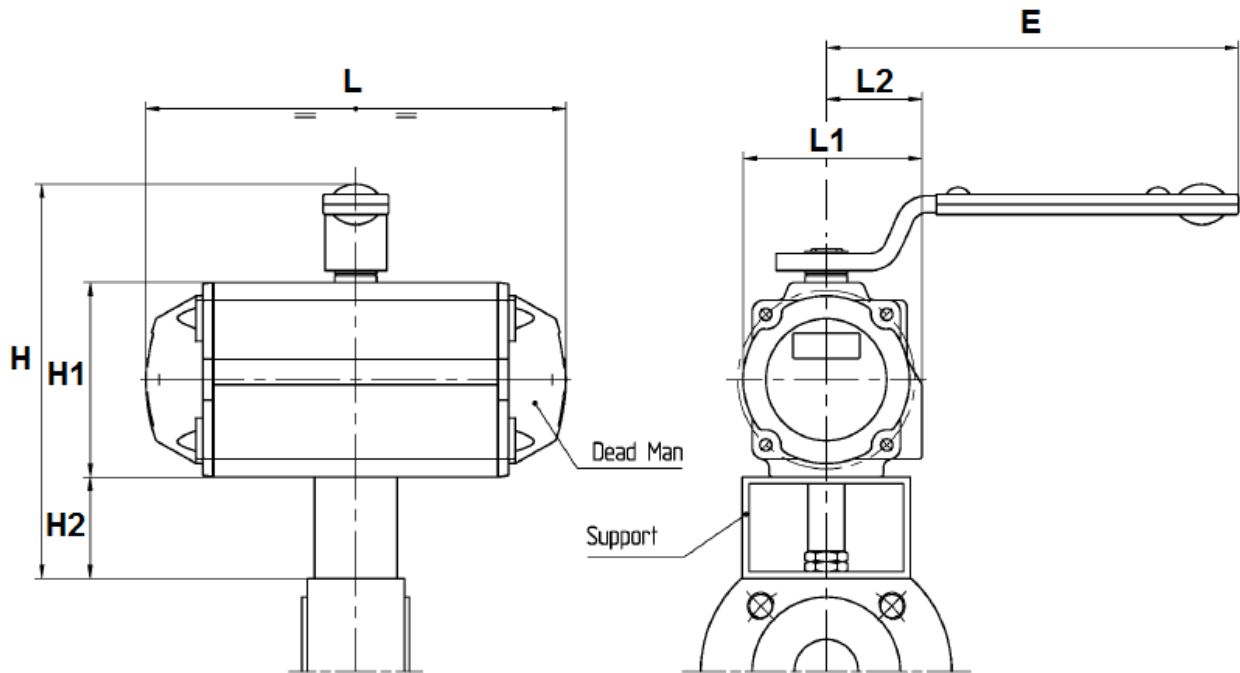

NPS (")	1/2"	3/4"	1"	1"1/4	1"1/2	2"
DN (mm)	15	20	25	32	40	50
Ref.	9830160	9830161	9830162	9830163	9830164	9830165
L	142	142	161	161	214	252
L1	70.5	70.5	83.5	83.5	94	105
L2	41.5	41.5	47.5	47.5	51	55.5
E	185	185	185	185	280	370
H	157	157	169	169	215	233
H1	69	69	85	85	102	115
H2	40	40	40	40	60	60

2 PIECES FLANGES BALL VALVE CLASS 150 PN20 FIRE SAFE ADLER TYPE FE2 CARBON STEEL

GEAR BOX SIZE (in mm) :

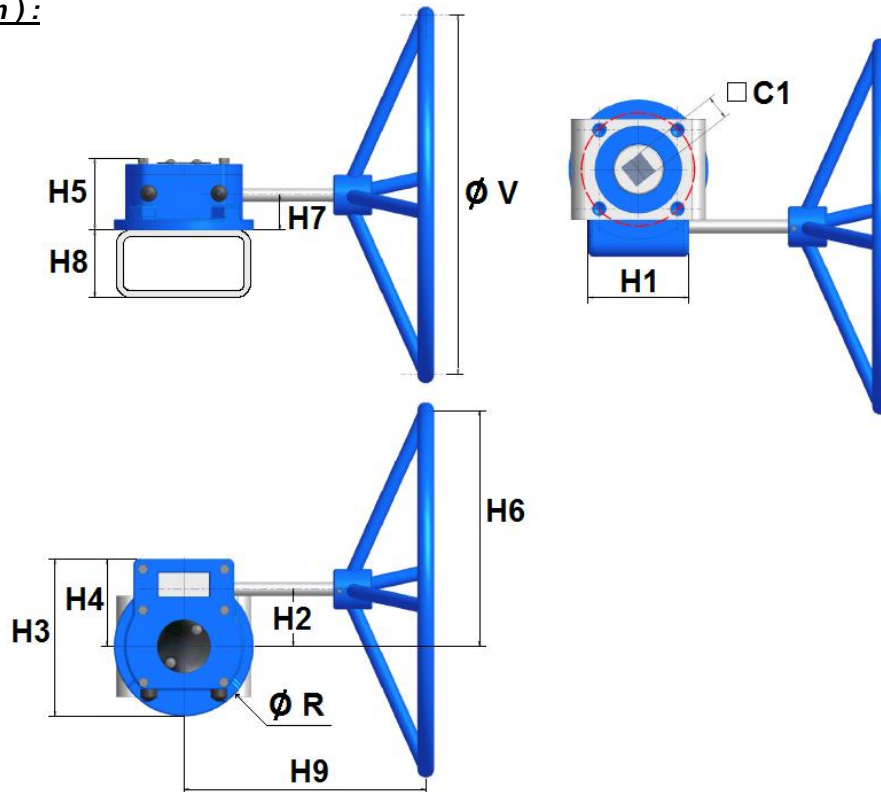

NPS (")	1/2" - 2"	2"1/2 - 3"	4" - 6"	8"
DN (mm)	15-50	65-80	100-150	200
C1	22	22	22	27
H1	57	57	100	120
H2	46	46	55	74
H3	98	98	143	188
H4	50.5	50.5	79.5	99
H5	56	56	73	97
H6	106	146	205	274
H7	34	34	35	48
H8	60	60	80	80
H9	117	131	250	274
Ø R	98	98	143	188
Ø V	120	200	300	400
Weight (Kg)	2.2	2.3	4.5	9.1
Ref.	9830260	9830261	9830262	9830263

2 PIECES FLANGES BALL VALVE CLASS 150 PN20 FIRE SAFE ADLER TYPE FE2 CARBON STEEL

GEAR BOX SPECIFICATIONS :

NPS (")	1/2" - 2"	2"1/2 - 3"	4" - 6"	8"
DN (mm)	15-50	65-80	100-150	200
Ref.	9830260	9830261	9830262	9830263
Ratio factor	40 :1	40 :1	37 :1	34 :1
Input torque (Nm)	35	34	43	83
Output torque (Nm)	100	150	500	1000

STANDARDS :

- Manufacturer certified ISO 9001:2015
- DIRECTIVE 2014/68/EU : CE N° 0038
Risk category III module H
- Designing according to BS EN 12516-2
- Construction according to ISO 14313
- Materials according to NACE MR 01-75
- Tests according to ANSI B16.34
- Marking according to EN 19
- Fire safe according to ISO 10497
- Fugitive emissions according to ISO 15848-1 : 2003 A Class
- SIL3 according to IEC/EN 61508 (on request)
- Flanges Class 150 (PN20) R.F. according to ASME B16.5
- ISO 5211 mounting pad
- Length according to ASME B16.10 (EN 558 series 3 up to DN150, series 4 for DN200)
- ATEX Group II Category 2 GDc TX Zone 1 & 21 Zone 2 & 22 (optional marking)

ADVICE : Our opinion and our advice are not guaranteed and SFERACO shall not be liable for the consequences of damages.
The customer must check the right choice of the products with the real service conditions.