

3 PIECES BALL VALVE WITH ISO MOUNTING PAD PN 63 PERFORMANCE RANGE BW

3 pieces carbon steel ball valve with full bore for Chemical industries, petrochemical industries, hydraulic installation, heating, water distribution, compressed air.

Fugitive emission according to TA LUFT for an excellent tightness on the stem and to prevent external leakage

PTFE filled with carbon packing, Viton® O ring gasket and PTFE filled with stainless steel seat.

Compatible with explosive atmosphere, ATEX Zone 1&21 and Zone 2&22 thanks to the antistatic device.

Thanks to the ISO 5211 plate, an actuator can be installed directly on the valve.



Size : DN8 to DN100 (NPS 1/4" to 4")

Connection : BW

Min Temperature : -20°C

Max Temperature : +220°C

Max Pressure : 63 Bars up to DN50, then 40 Bars

Specifications : ATEX

ISO 5211 direct mounting pad

Anti blow-out stem, full bore

Fugitive emissions TA LUFT

PTFE filled with stainless steel seat

Materials : Carbon steel EN 1.0619



3 PIECES BALL VALVE WITH ISO MOUNTING PAD PN 63 PERFORMANCE RANGE BW

SPECIFICATIONS :

- Full bore
- Anti blow-out stem
- Special gland pack with elastic washer
- Antistatic device from DN8 to 32, double antistatic device (ball between body-stem and ball-stem) from DN40 to 100
- PTFE filled with stainless steel seat
- Locking device
- Blue handle cover possible
- ISO 5211 direct mounting pad
- Black oxide finish

USE :

- Chemical and pharmaceutical industries, petrochemical industries, hydraulic installation, compressed air
- Steam : 18 bars maximum
- Vacuum : 10⁻² torr
- Min and max Temperature Ts : -20°C to + 220°C
- Max Pressure Ps : 63 bars up to DN50 and 40 bars over (see graph)

PRESSURE / TEMPERATURE GRAPH :

Pressure (Bar)

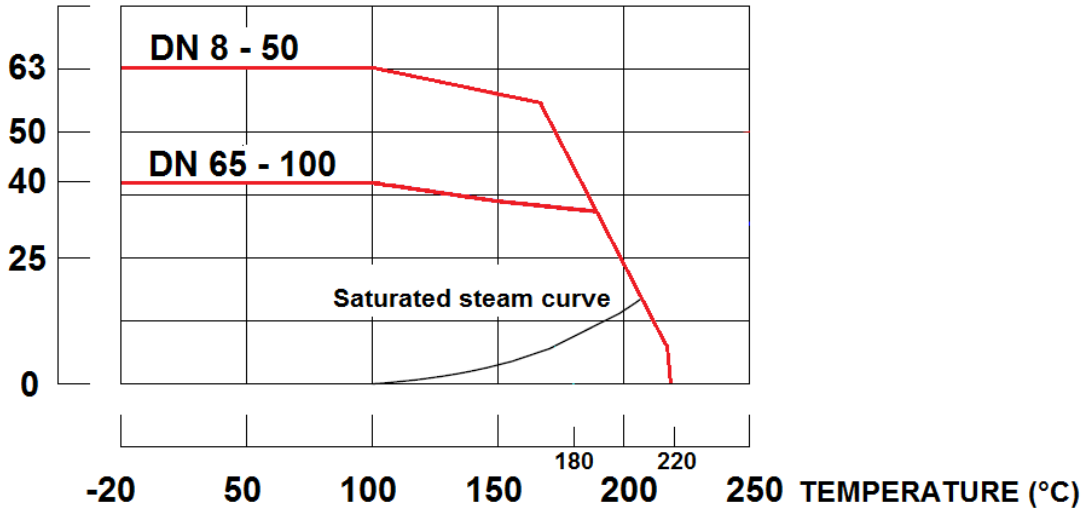

TORQUE VALUES (in Nm without safety coefficient) :

DN (mm)	8	10	15	20	25	32	40	50	65	80	100
NPS (")	1/4"	3/8"	1/2"	3/4"	1"	1"1/4	1"1/2	2"	2"1/2	3"	4"
Torque (Nm)	7.6	7.6	7.6	14.5	21	25	35	60	80	88	190



3 PIECES BALL VALVE WITH ISO MOUNTING PAD PN 63 PERFORMANCE RANGE BW

BOLT TIGHTENING TABLE (in Nm):

DN (mm)	8	10	15	20	25	32	40	50	65	80	100
NPS (")	1/4"	3/8"	1/2"	3/4"	1"	1"1/4"	1"1/2"	2"	2"1/2"	3"	4"
Torque (Nm)	6.9	6.9	6.9	9.8	9.8	11.8	15.7	20.6	54.9	73.5	94.1

FLOW COEFFICIENT Kvs (M3 / h):

DN (mm)	8	10	15	20	25	32	40	50	65	80	100
NPS (")	1/4"	3/8"	1/2"	3/4"	1"	1"1/4"	1"1/2"	2"	2"1/2"	3"	4"
Kvs (m3/h)	17.2	21	31.3	57.9	94.3	157.9	227.9	414.8	720.2	1091	1754

RANGE :

- 3 pieces carbon steel ball valve Performance range **Ref. 738** from DN8 to DN 100
- Blue handle cover **Ref. 9830432-9830436** from DN 8 to DN 100

CONNECTION :

- Butt Welding **Ref. 738**

3 PIECES BALL VALVE WITH ISO MOUNTING PAD PN 63 PERFORMANCE RANGE BW

MATERIALS :

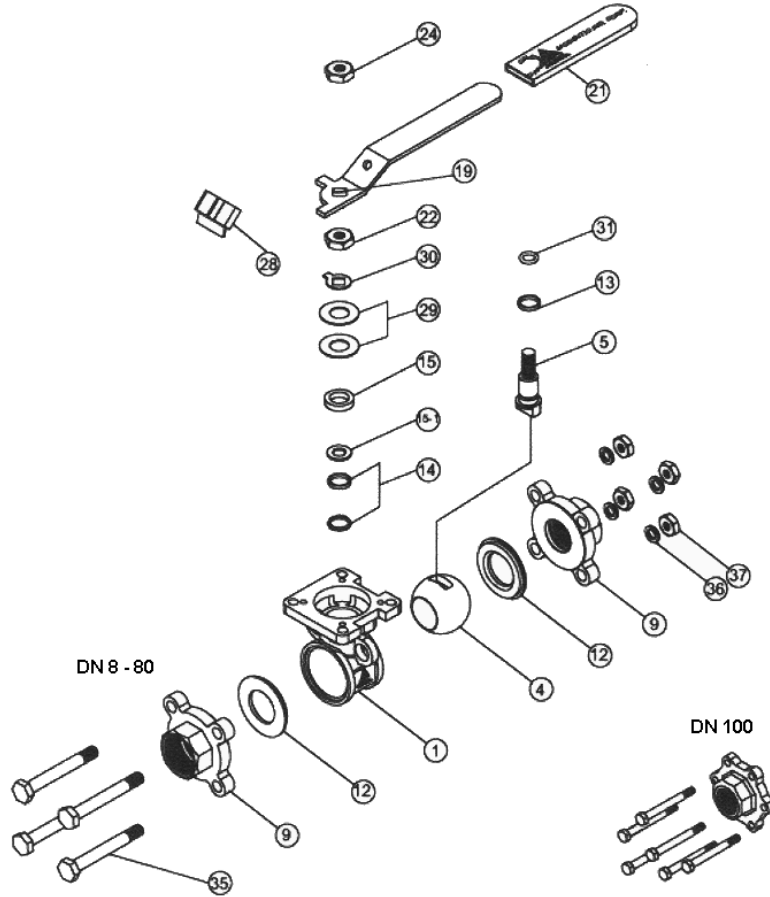

Item	Designation	Materials
1	Body	EN 1.0619
4	Ball	ASTM A351 CF8M
5	Stem	AISI 316
9	Ends	EN 1.0619
12*	Seat	PTFE with 50% AISI 316
13*	Thrust washer	PTFE with 25% carbon
14*	Stem packing	
15-1*	Packing Follwer	PTFE with 25% glass
15	Gland bush	AISI 304
19	Handle	
21	Handle cover	Plastic
22	Stem nut	AISI 304
24	Handle nut	
28	Locking device	AISI 301
29	Elastic washer	
30	Tab washer	AISI 304
31*	O-ring	Viton®
35	Body bolt	AISI 304
36	Bolt washer	
37	Bolt nut	

(* : included in gaskets kit)

3 PIECES BALL VALVE WITH ISO MOUNTING PAD PN 63 PERFORMANCE RANGE BW

SIZE (in mm) :

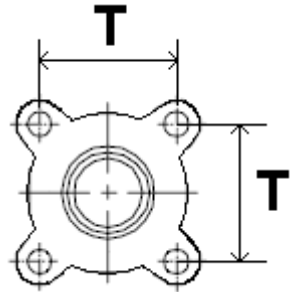
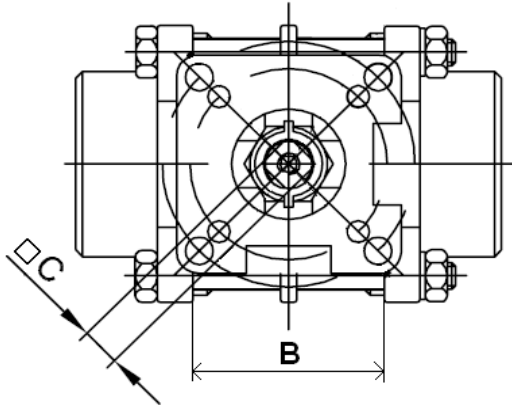

DN 8 – 80

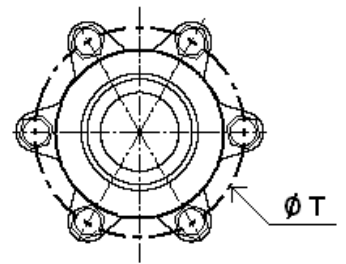
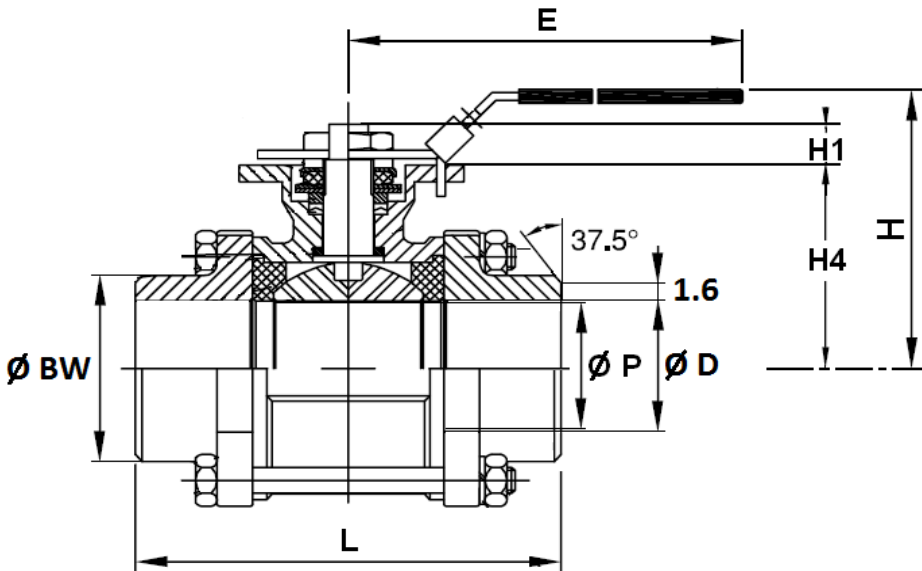

DN 100

Stem size :

DN (mm)	8	10	15	20	25	32	40	50	65	80	100
NPS (")	1/4"	3/8"	1/2"	3/4"	1"	1"1/4"	1"1/2"	2"	2"1/2"	3"	4"
Ø D	11	12.5	15.8	20.9	26.6	35.1	40.9	52.5	62.7	77.9	102.3
Ø P	11	12.5	15	20	25	32	38.1	50	62.7	77.9	100
L	63.5	63.5	63.5	72.5	81	94.5	108	121.5	157.5	190	225
B	22.5	22.5	22.5	27.5	34	42.5	52	63.5	85.5	102	128.5
E	112	112	112	112	136	185	197.9	197.9	267	267	322
H	73	73	73	80.8	90.5	98.7	115.3	124	155	164.5	216.7
H1	8.5	8.5	8.5	8.5	9.5	9.5	14	13.7	18	18	18
H4	37	37	37	45	53.5	59	74.8	83.5	108.8	118.3	153.8
C	9	9	9	9	9	9	14	14	17	17	17
T	31	31	31	35	41	49	59	71	91	107	195
Ø BW	13.7	17.1	21.3	26.7	33.4	42.2	48.3	60.3	73	88.9	114.3
Weight (in Kg)	0.55	0.58	0.57	0.71	1	1.56	2.5	3.6	7.6	10.98	21
Ref.	738008	738010	738015	738020	738025	738032	738040	738050	738065	738080	738100

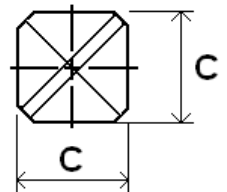

3 PIECES BALL VALVE WITH ISO MOUNTING PAD PN 63 PERFORMANCE RANGE BW

ISO MOUNTING PAD AND STEM SIZE (in mm) :

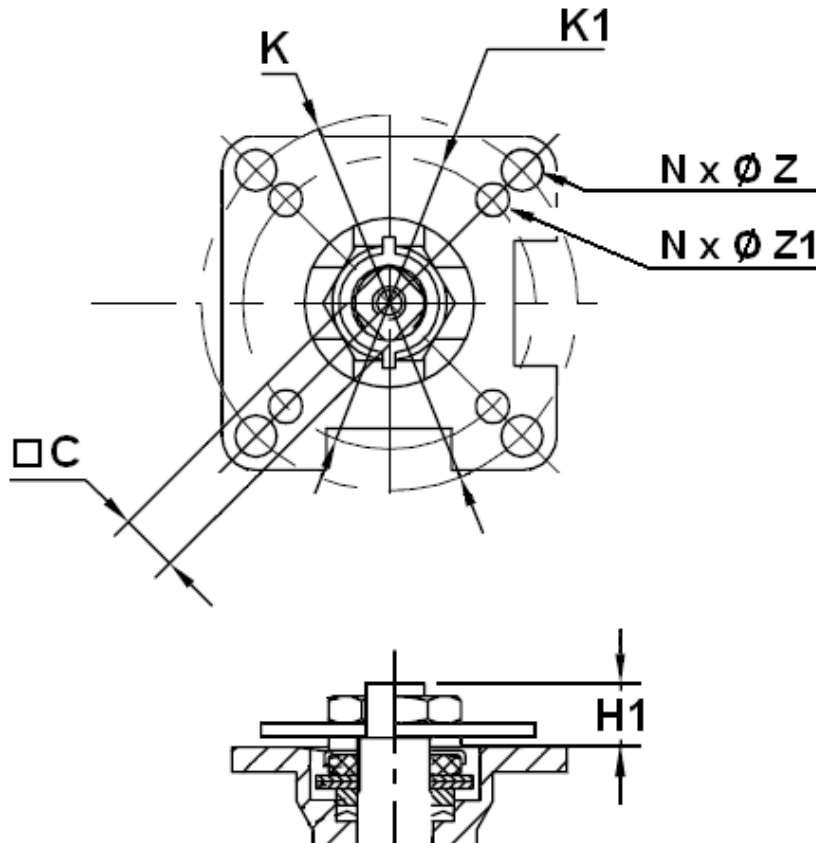

DN (mm)	8	10	15	20	25	32	40	50	65	80	100
NPS (")	1/4"	3/8"	1/2"	3/4"	1"	1"1/4"	1"1/2"	2"	2"1/2"	3"	4"
C	9	9	9	9	9	9	14	14	17	17	17
H1	8.5	8.5	8.5	8.5	9.5	9.5	14	13.7	18	18	18
Ø K	50	50	50	50	50	50	70	70	102	102	102
ISO	F05	F05	F05	F05	F05	F05	F07	F07	F10	F10	F10
N x Ø Z	4 x 7	4 x 7	4 x 7	4 x 7	4 x 7	4 x 7	4 x 9	4 x 9	4 x 11	4 x 11	4 x 11
Ø K1	36	36	36	36	36	36	50	50	70	70	70
ISO 1	F03	F03	F03	F03	F03	F03	F05	F05	F07	F07	F07
N x Ø Z1	4 x 6	4 x 6	4 x 6	4 x 6	4 x 6	4 x 6	4 x 7	4 x 7	4 x 9	4 x 9	4 x 9



3 PIECES BALL VALVE WITH ISO MOUNTING PAD PN 63 PERFORMANCE RANGE BW

STANDARDS :

- Manufacturer certified ISO 9001 : 2015
- DIRECTIVE 2014/68/EU : CE N° 0038 or 0343
Risk category III Module H
- Certificate 3.1 on request
- Construction according EN 12516
- Designing according to ASME B16.34
- Pressure tests according to EN 12266-1, rate A
- B.W. ends according to ASME B36.10 Schedule 40
- ISO 5211 mounting pad
- ATEX Group II Category 2 G/2D Zone 1 & 21 Zone 2 & 22 (optional marking) according directive 2014/34/EU
- Tightness on stem according to TA LUFT VDI 2440/3.3.1.3

ADVICE : Our opinion and our advice are not guaranteed and SFERACO shall not be liable for the consequences of damages.
The customer must check the right choice of the products with the real service conditions.