

3 PIECES STAINLESS STEEL BALL VALVE FEMALE NPT INITIAL RANGE

PRODUCT EVOLUTION



Be careful, our valves Ref.744 are changing

**We currently have 2 different types available (according to DN)
with different dimensions and non-commutable gaskets**

Old marking :



New marking :



At the end, only the new type will be available (from page 2 to 9)

3 PIECES STAINLESS STEEL BALL VALVE FEMALE NPT INITIAL RANGE

3 pieces carbon steel ball valve with full bore for Chemical industries, petrochemical industries, hydraulic installation, heating, water distribution and compressed air.
PTFE packing and gasket, PTFE filled with 15% glass seat.
Removable central part for an easy maintenance.

Certificate
3.1



NEW



Size : DN1/4" to DN4"
Connection : Female NPT
Min Temperature : -20°C
Max Temperature : +180°C
Max Pressure : 63 bars (up to DN3/4")
Specifications : 3 pieces type
PTFE filled with 15% glass seat
Anti blow-out stem
Full bore

Materials : Stainless Steel ASTM A351 CF8M

3 PIECES STAINLESS STEEL BALL VALVE FEMALE NPT INITIAL RANGE

SPECIFICATIONS :

- Full bore
- Anti blow-out stem
- PTFE packing
- Locking device
- Stem extension in AISI 304 (option)

USE :

- Chemical and pharmaceutical industries, petrochemical industries, hydraulic installation, compressed air
- Min and max Temperature Ts : -20°C to + 180°C
- Max Pressure Ps : 63 bars up to DN20, 40 bars from DN25 to 50, 25 bars from DN65 to 80 and 20 bars for DN100 (see graph under)
- Compressed air : 10 bars max
- Do not use with steam

PRESSURE / TEMPERATURE GRAPH (STEAM AND COMPRESSED AIR EXCLUDED) :

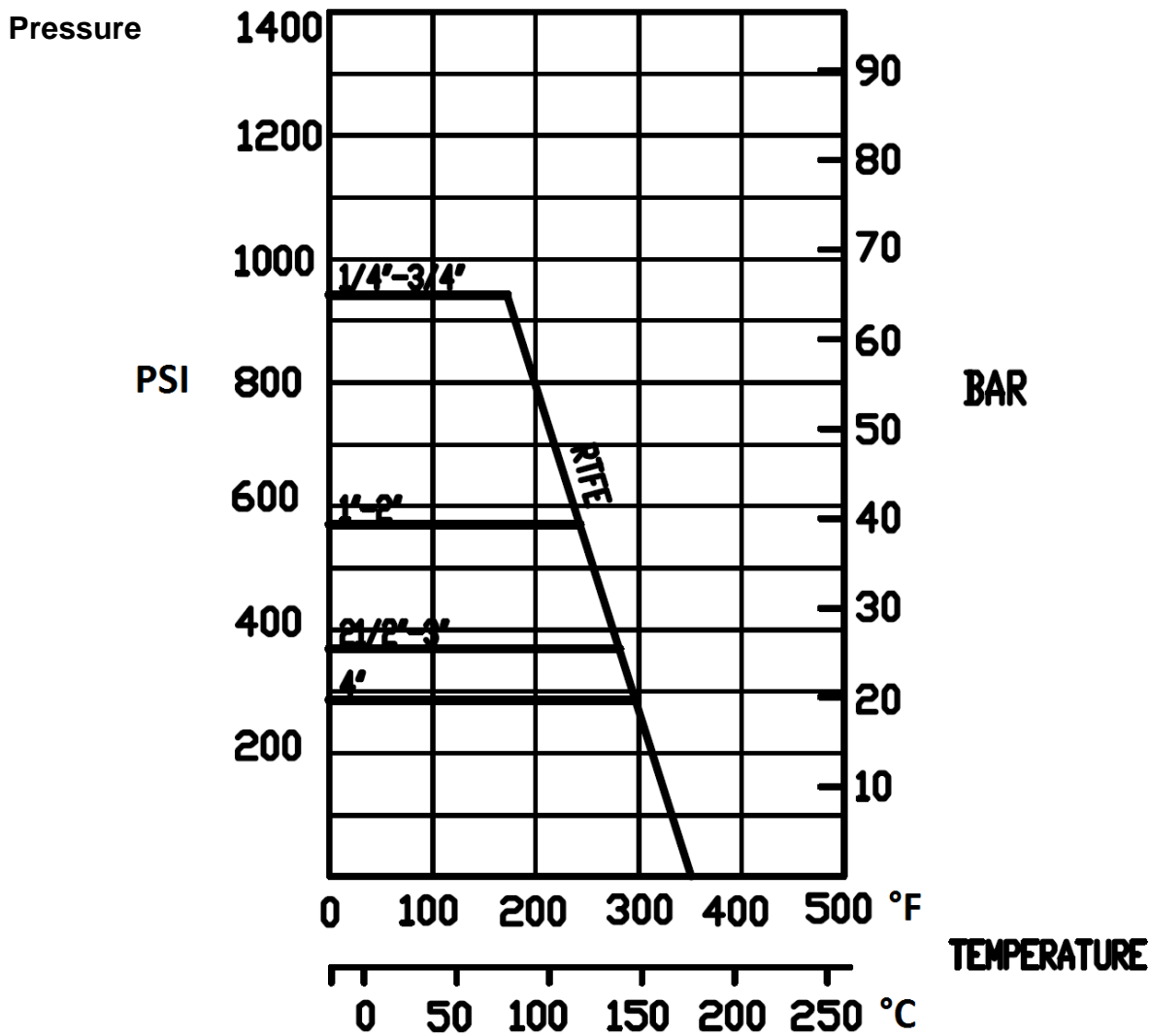

3 PIECES STAINLESS STEEL BALL VALVE FEMALE NPT INITIAL RANGE

TORQUE VALUES (In Nm without safety coefficient) :

DN	1/4"	3/8"	1/2"	3/4"	1"	1"1/4"	1"1/2"	2"	2"1/2"	3"	4"
Torque (Nm)	2	2	2.5	3.5	6	7	12	16	40	50	70

BOLT TIGHTENING TABLE (in Nm) :

DN	1/4"	3/8"	1/2"	3/4"	1"	1"1/4"	1"1/2"	2"	2"1/2"	3"	4"
Torque (Nm)	4	4	8	8	10	13	20	20	35	45	65

FLOW COEFFICIENT Kvs (M3 / h) :

DN	1/4"	3/8"	1/2"	3/4"	1"	1"1/4"	1"1/2"	2"	2"1/2"	3"	4"
Kvs (m3/h)	5.2	5.2	20.7	30.2	40.6	70	90.8	208.4	275.9	501.6	865

RANGE :



- Stainless steel 3 pieces ball valve Initial Range Female NPT **Ref. 744** from DN1/4" to DN4"



- AISI 304 stem extension **Ref.9810611-9810614** from DN8 to DN50



- Blue handle cover **Ref. 9830584-9830588** from DN 1/2" to DN 4"

CONNECTION :

- Female / female threaded NPT

3 PIECES STAINLESS STEEL BALL VALVE FEMALE NPT INITIAL RANGE

MATERIALS :

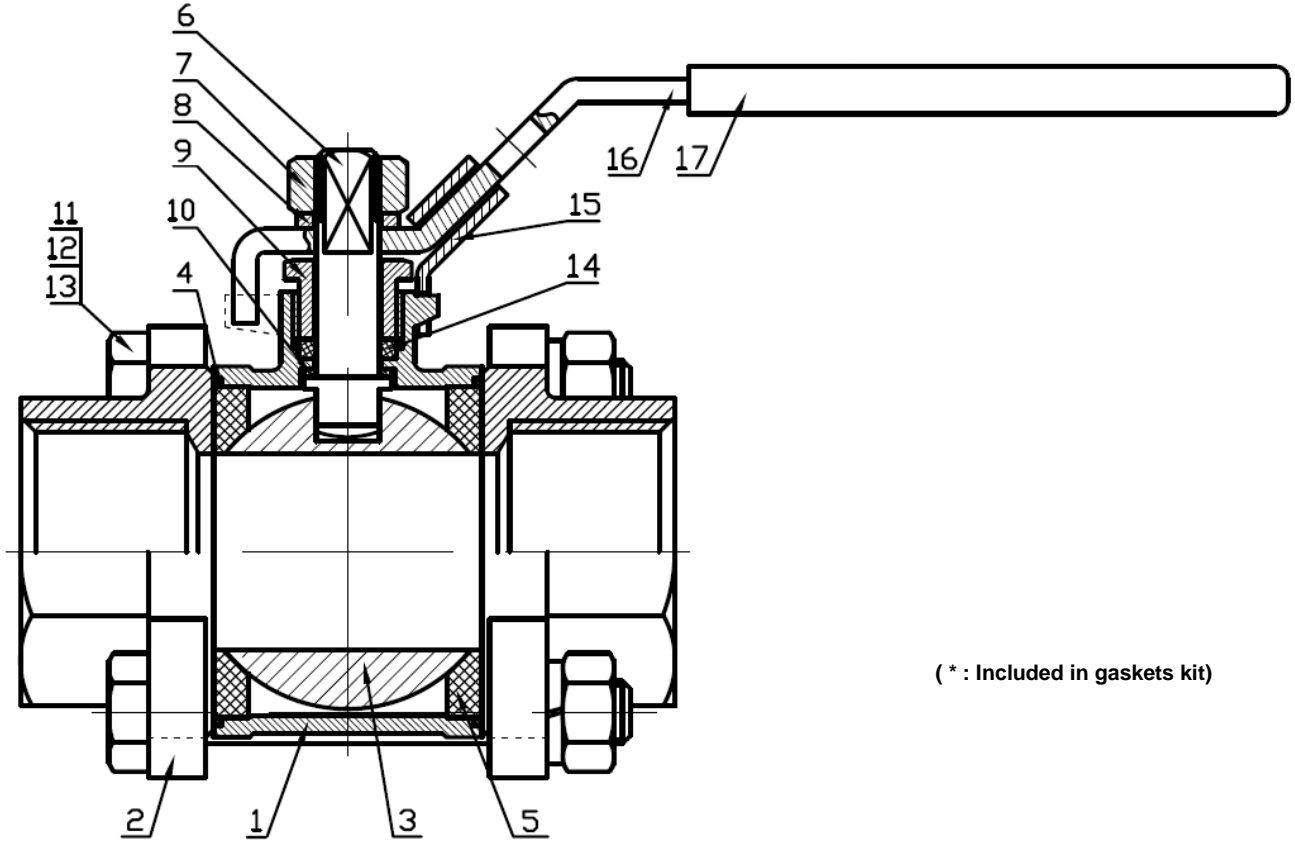

(* : Included in gaskets kit)

Item	Designation	Materials
1	Body	ASTM A351 CF8M
2	Ends	
3	Ball	AISI 316
4*	Body gasket	PTFE
5*	Seat	PTFE filled with 15% glass fiber
6	Stem	AISI 316
7	Packing nut	AISI 304
8	Handle washer	
9	Packing gland	
10*	Thrust washer	PTFE
11	Stud	AISI 304
12	Stud washer	
13	Stud nut	
14*	Packing	PTFE
15	Locking device	AISI 304
16	Handle	
17	Handle cover	PVC

3 PIECES STAINLESS STEEL BALL VALVE FEMALE NPT INITIAL RANGE

SIZE:

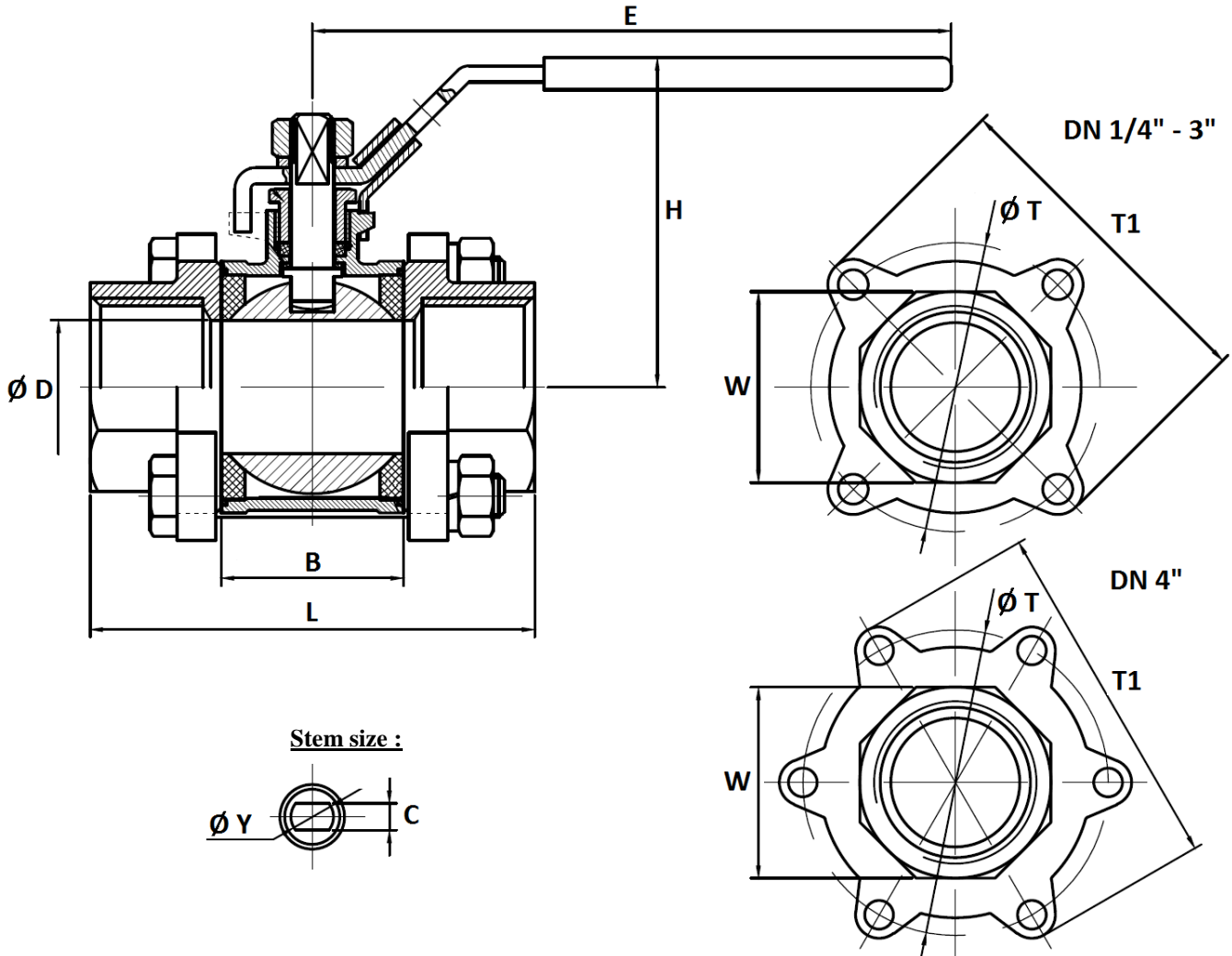

Stem size :

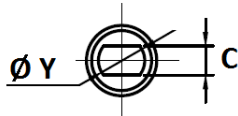

DN	1/4"	3/8"	1/2"	3/4"	1"	1 1/4"	1 1/2"	2"	2 1/2"	3"	4"
Ø D	11.6	12.5	15	20	25	32	38	50	64	76	100
L	59	59	63.3	70.6	82	97	109	124.6	162	175	216
B	21.1	21.1	23.3	28.6	34	44	51	63	84.3	94.7	119.2
E	103	103	126	126	162	162	193	193	230	230	320
H	49	49	57	62	72	78	91	102	122	132	177
Ø Y	M8	M8	M8	M8	M10	M10	M12	M12	M14	M14	M20
C	5	5	5	5	6.5	6.5	8.5	8.5	9.8	9.8	16
Ø T	38.5	38.5	43	51.5	58	70	81.5	101	136	157	195.5
T1	51	51	57.5	66	74.5	86.5	100.5	121.5	161	185	226.5
W	18	21	26	32	39	48	55	67	83	99	127
Weight (Kg)	0.3	0.3	0.48	0.63	0.93	1.38	2.03	3.28	7.11	10.45	21.24
Ref.	744002	744003	744004	744005	744006	744007	744008	744009	744010	744011	744012

3 PIECES STAINLESS STEEL BALL VALVE FEMALE NPT INITIAL RANGE

STEM EXTENSION (in mm) :

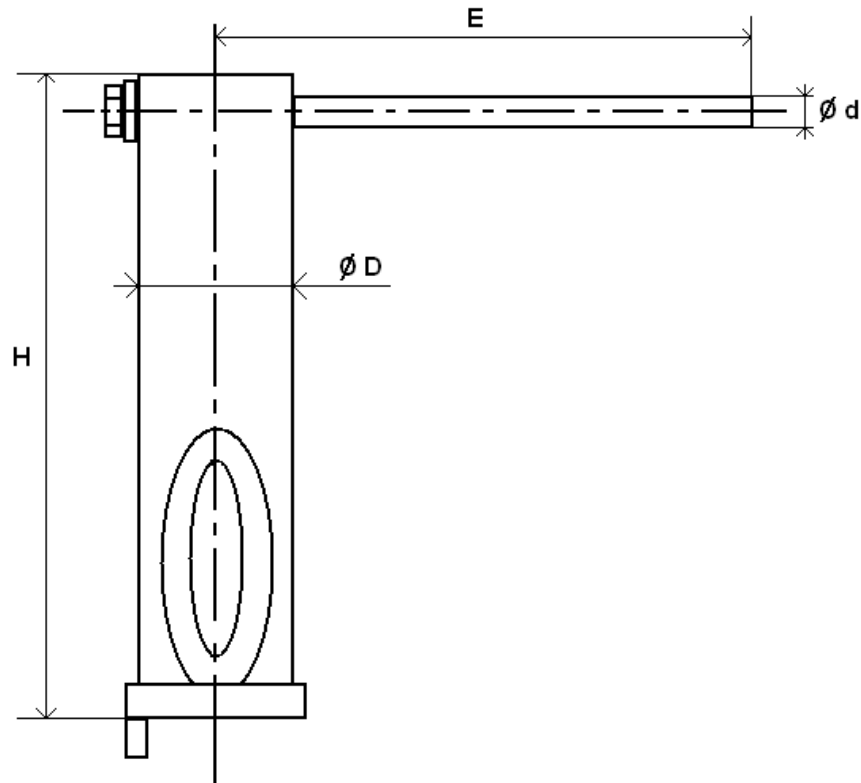

DN	1/4"	3/8"	1/2"	3/4"	1"	1"1/4"	1"1/2"	2"
H	126		126.3		126.3		128	
E	124		124		157.8		188.5	
Ø D	28		28		32		36.5	
Ø d	12		12		14		14	
Weight (in Kg)	0.33		0.34		0.48		0.62	
Ref.	9810611		9810612		9810613		9810614	



3 PIECES STAINLESS STEEL BALL VALVE FEMALE NPT INITIAL RANGE

STANDARDS :

- Manufacturer certified ISO 9001 : 2015
- DIRECTIVE 2014/68/EU : For liquids and gas of Group 1
 - DN1/4"-1" : Article 4, §3 (SEP), no CE marking
 - DN1"1/4-4" : Risk Category II, CE 0038 or CE 0343 marking
- Designing according to EN 12516-2
- Certificate 3.1 on request
- Pressure tests according to API 598, table 6
- Threaded NPT ends according to ANSI B1.20.1

ADVICE : Our opinion and our advice are not guaranteed and SFERACO shall not be liable for the consequences of damages.
The customer must check the right choice of the products with the real service conditions.

3 PIECES STAINLESS STEEL BALL VALVE FEMALE NPT INITIAL RANGE

INSTALLATION AND MAINTENANCE

BEFORE INSTALLATION :

Pipe-line must be cleaned and free from residual of weldings, rubbish, shaving and every kind of extraneous materials.
Pipe-line must be perfectly aligned and their support properly dimensioned so that there's no external constraint.

Check to use a produce compatible to the services conditions for the sealing of the threaded types.
To tighten the ends, use the appropriate tool.
Use the right bolt tightening so that the ends won't be damaged.

The welding of the ends for the SW and the BW types, must be done with the central part removed.
A gauge can be used to have the good length and alignment between the ends.

INSTALLATION OF THE CENTRAL PART

During the installation of the central part, tighten bolts according to the table below. Tighten bolts in cross.

BOLT TIGHTENING TABLE (in Nm) :

DN	1/4"	3/8"	1/2"	3/4"	1"	1"1/4	1"1/2	2"	2"1/2	3"	4"
Torque (Nm)	4	4	8	8	10	13	20	20	35	45	65

CLEANING AND TESTS

Keep opened the valves during the cleaning operation so that there are no impurities between the ball and the body.

Tests under pressure must be done with a cleaned pipe-line.

Open partially the valve for tests. Pressure test do not exceed the valve specifications according to EN 12266-1.

MAINTENANCE

It's recommended to operate the valve twice (open and close) 1 to 2 times per year.

When intervention on the valve, be sure there's no pressure in the pipe-line, there's no fluid in it, and that it is isolated.
The temperature must be low enough to operate without risks.
If there's a corrosive fluid, inert installation before intervention.

When the valve is under pressure :
If there's a leakage between the body and the ends, tighten bolts according to the above table

If there's a leakage at the packing, tighten it slightly so that the leakage disappears.

MAINTENANCE OPERATION IN WORKSHOP

REPLACEMENT OF SEAT GASKETS AND PACKING.

The central part must be removed.

Turn the ball at 45° and removed the seat gaskets.

Operate the valve in closed position to removed the ball. Verify the surface of the ball has no impacts and no scores.

If there are important scores or impacts, replace the ball.

Clean inside the body valve and remove the impurities.

To replace the packing, remove the handle, unscrew the gland nut, extract the stem by the inside of the valve.

Clean the packing seat.

Reassemble thrust washer on stem, introduce stem by the inside of the valve, reassemble packing with packing nut, reassemble hand washer, hand nut and the handle.

Turn stem in closed position and insert the ball.

Then turn the ball in opened position and reassemble the seat.

Place the valve on the installation, tighten bolts according to the above table.

Then proceed to the tests in the same way that the first installation.

3 PIECES STAINLESS STEEL BALL VALVE FEMALE NPT INITIAL RANGE



Size : DN 8 to 100 mm
Ends : Threaded NPT
Min Temperature : -20°C
Max Temperature : + 180°C
Max Pressure : 63 Bars up to DN20
Specifications : Anti blow-out stem
Locking device
Full bore

Materials : Stainless steel ASTM A351 CF8M

3 PIECES STAINLESS STEEL BALL VALVE FEMALE NPT INITIAL RANGE

SPECIFICATIONS :

- Full bore
- Anto blow-out stem
- PTFE packing
- Locking device
- Stem extension in SS 304 (option)
- Blue handle cover possible

USE :

- Chemical and pharmaceutical industries, petrochemical industries
- Min and max Temperature Ts : -20°C to + 180°C
- Max Pressure Ps : 63 bars up to DN20, 40 bars from DN25 to 50, 25 bars from DN65 to 80 and 20 bars for DN100 (see graph under)
- Do not use with steam

PRESSURE / TEMPERATURE GRAPH (STEAM AND COMPRESSED AIR EXCLUDED) :

Pressure (Bar)

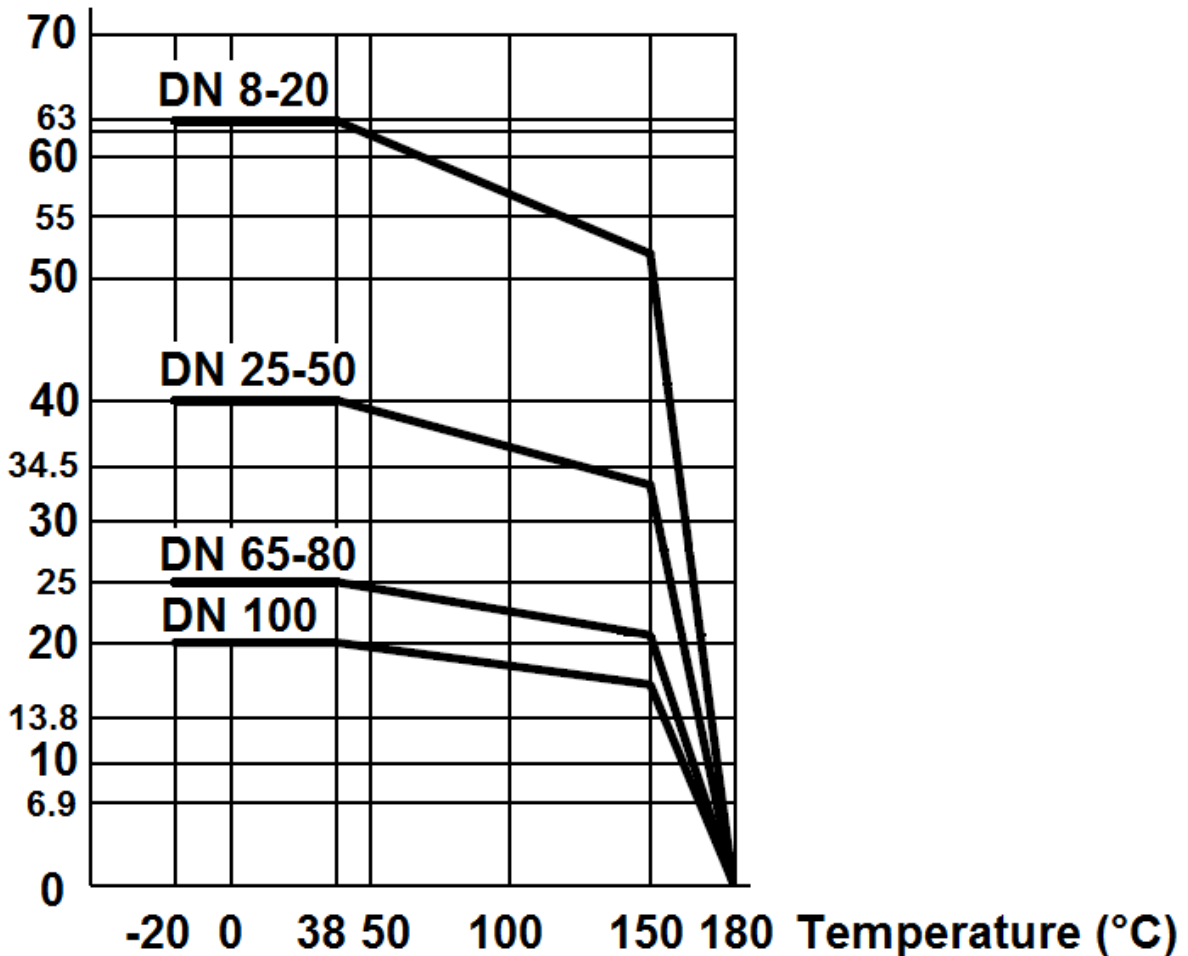

3 PIECES STAINLESS STEEL BALL VALVE FEMALE NPT INITIAL RANGE

RANGE :

- Stainless steel 3 pieces ball valve Ref. **744** from DN 8 to DN 100
- Blue handle cover Ref. **9830444-9830449** from DN 8 to DN 100

ENDS :

- Female / female threaded NPT Ref. **744**

MATERIALS FOR DN8 AND FROM DN15 TO 100 :

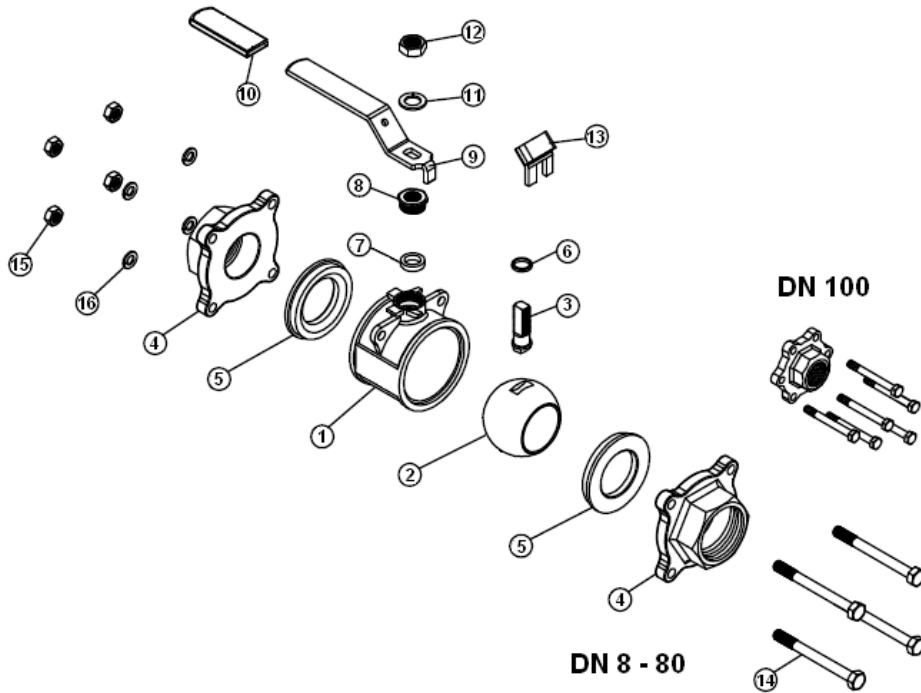

Item	Designation	Materials DN8 and DN15-100
1	Body	ASTM A351 CF8M
2	Ball	ASTM A351 CF8M
3	Stem	SS 316
4	Ends	ASTM A351 CF8M
5*	Seat	PTFE filled with 15% glass fiber
6*	Thrust washer	PTFE
7*	Packing	PTFE
8	Packing nut	SS 304
9	Handle	SS 304
10	Handle cover	Plastic
11	Handle washer	SS 304
12	Handle nut	SS 304
13	Locking device	SS 304
14	Bolt	SS 201
15	Nut	SS 304
16	Washer	SS 304

(* : Included in gaskets kit)

3 PIECES STAINLESS STEEL BALL VALVE FEMALE NPT INITIAL RANGE

MATERIALS FOR DN10 :

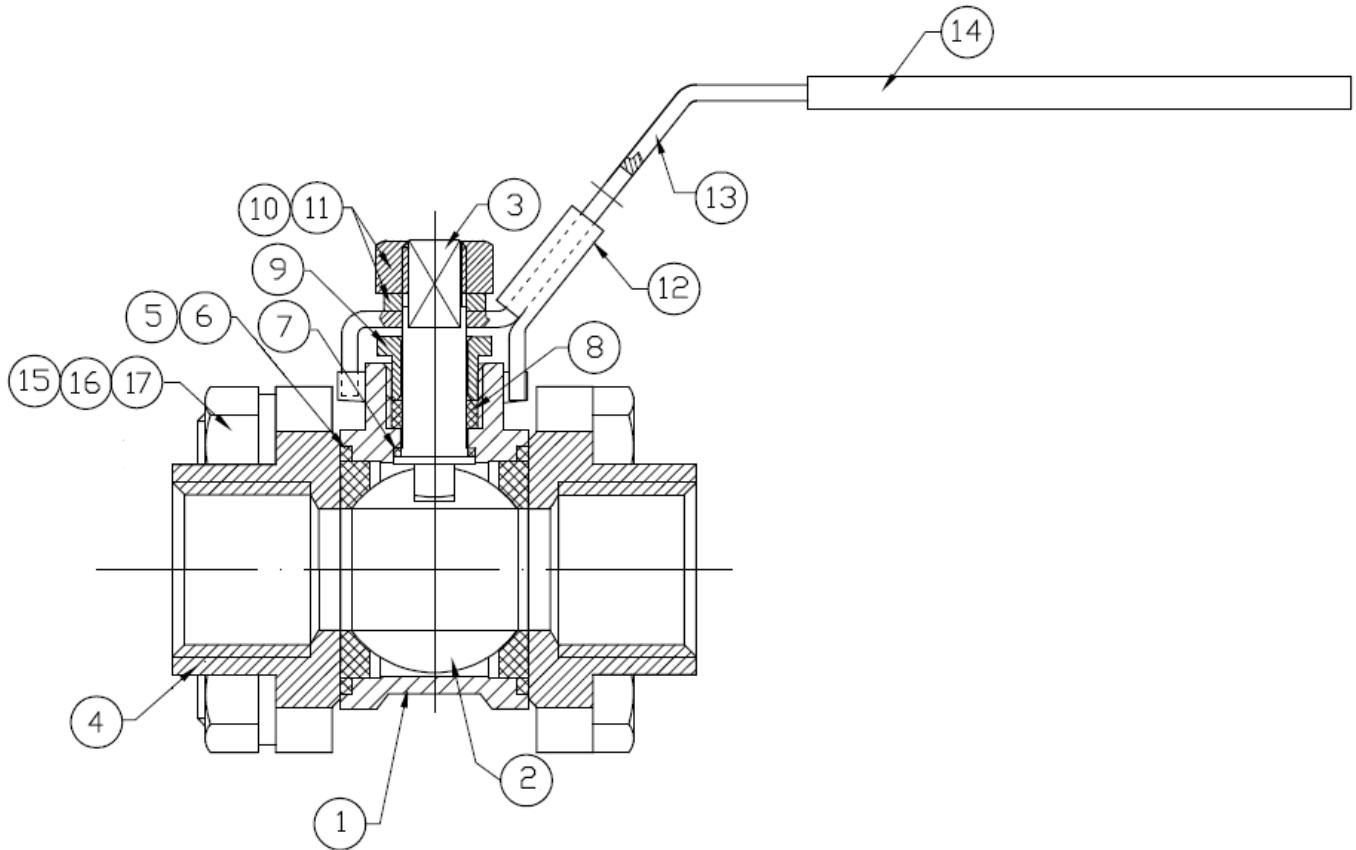

Item	Designation	Materials DN10
1	Body	ASTM A351 CF8M
2	Ball	ASTM A351 CF8M
3	Stem	SS 316
4	Ends	ASTM A351 CF8M
5*	Seat	PTFE filled with 15% glass fiber
6*	Body gasket	PTFE filled with 15% glass fiber
7*	Thrust washer	PTFE
8*	Packing	PTFE
9	Packing nut	SS 304
10	Handle nut	SS 304
11	Handle washer	SS 304
12	Locking device	SS 304
13	Handle	SS 304
14	Handle cover	Plastic
15	Bolt	SS 201
16	Nut	SS 304
17	Washer	SS 304

(* : Included in gaskets kit)

3 PIECES STAINLESS STEEL BALL VALVE FEMALE NPT INITIAL RANGE

SIZE (in mm) :

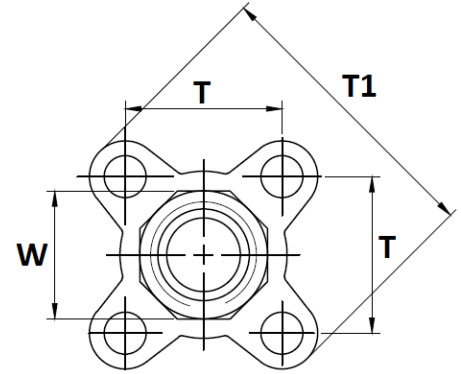
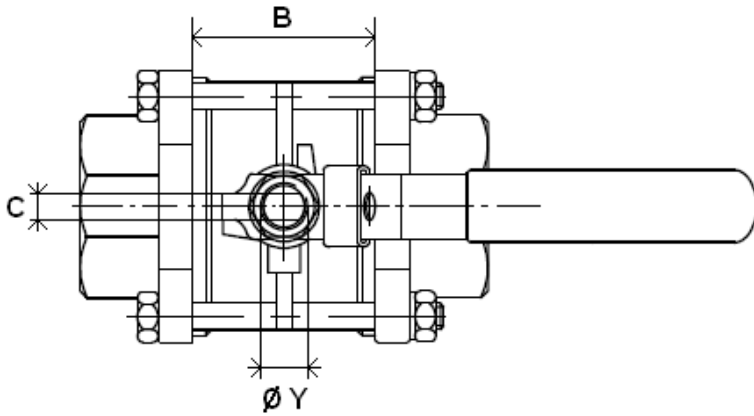

DN 1/4" - 3"

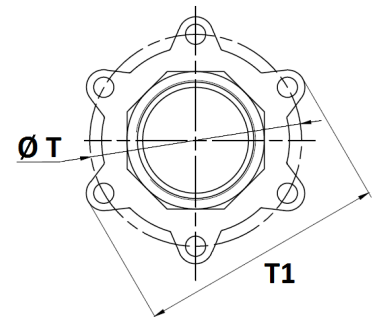

DN 4"

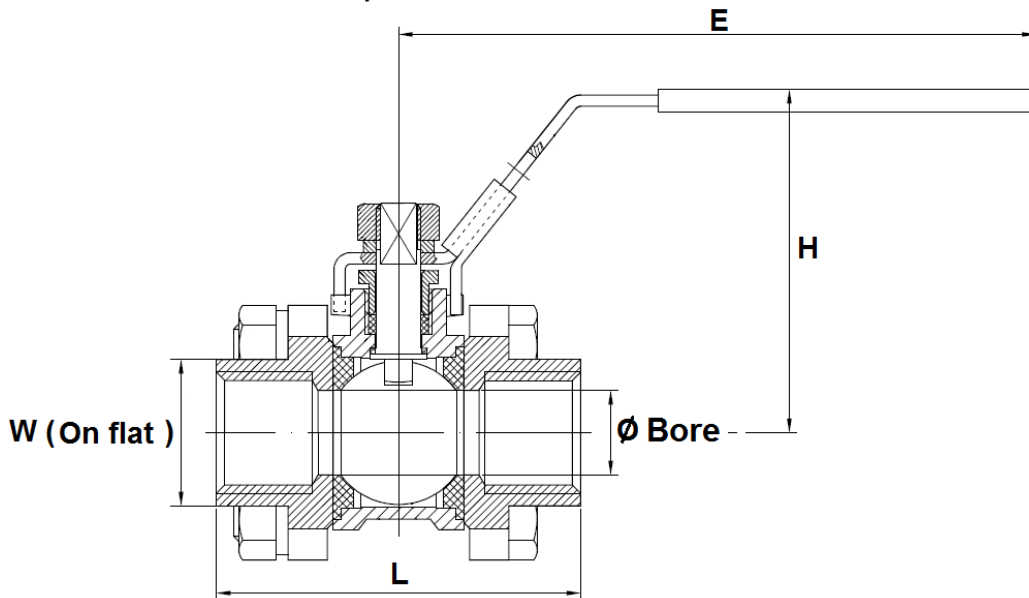

(2 parts seat for DN3/8")

Stem size :

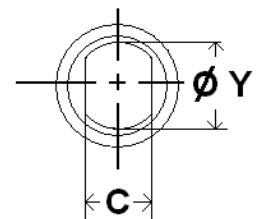

DN	1/4"	3/8"	1/2"	3/4"	1"	1"1/4"	1"1/2"	2"	2"1/2"	3"	4"
Ø Bore	9.2	12.8	15	20	25	32	38	50	65	80	100
L	60	60	63	70	82	96	107	124	164.6	182.7	217.7
B	22	22	23.3	28	34	43	49	62.4	88.1	100.2	119.1
E	136	136	136	136	165	165	190	190	300	300	335
H	52	52	63	68	79	88	97	108	128	140	172
Ø Y	8	8	8	8	10	10	12	12	14	14	20
C	5	5	5	5	6.5	6.5	8.5	8.5	9.8	9.8	16
T	27.2	27.2	31.8	40	45	53	63.3	78.8	98.3	116.6	200.5
T1	51	51	59.5	71	80	91.5	106	132.8	164	194	231.5
W	18	22	26	33	40	48	55	67	84.5	101	127
Weight (Kg)	0.33	0.34	0.49	0.64	0.96	1.37	2.2	3.75	6.85	10.2	20.5

3 PIECES STAINLESS STEEL BALL VALVE FEMALE NPT INITIAL RANGE

STEM EXTENSION (in mm) :

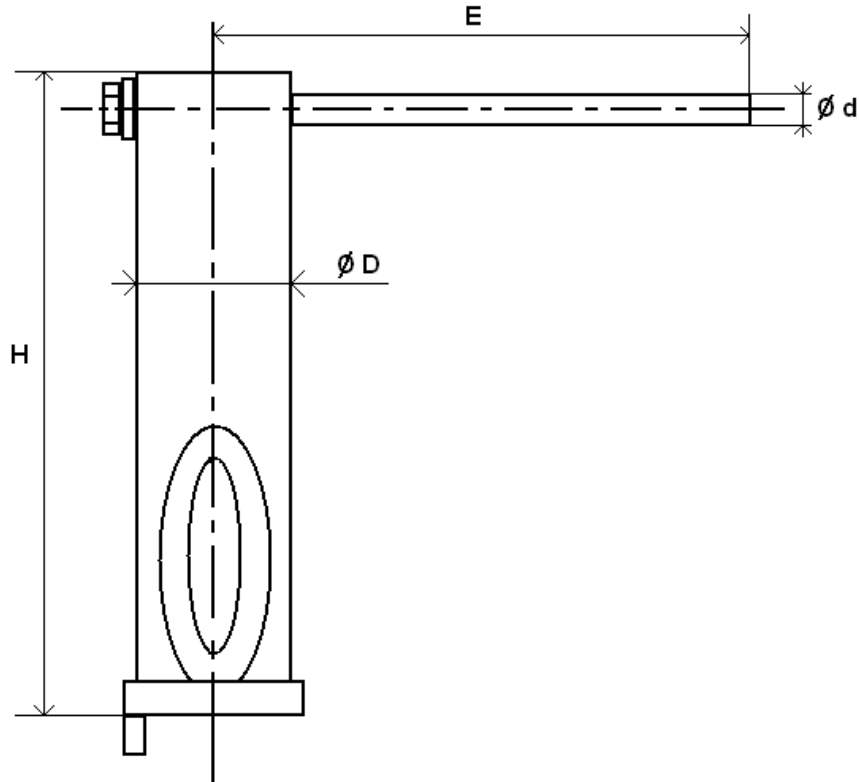

Ref.	DN	1/4"	3/8"	1/2"	3/4"	1"	1"1/4"	1"1/2"	2"
981060	H	125.5	125.5	125.5	125.5	125.5	125.5	127.5	127.5
	E	125	125	125	125	158	158	190	190
	Ø D	28	28	28	28	32	32	36	36
	Ø d	12	12	12	12	14	14	14	14
	Weight (Kg)	0.3	0.3	0.3	0.3	0.4	0.4	0.6	0.6

3 PIECES STAINLESS STEEL BALL VALVE FEMALE NPT INITIAL RANGE

TORQUE VALUES (In Nm without safety coefficient) :

DN	1/4"	3/8"	1/2"	3/4"	1"	1"1/4"	1"1/2"	2"	2"1/2"	3"	4"
Torque (Nm)	5	5	5	8	12.5	17	21	30	45	70	100

BOLT TIGHTENING TABLE (in Nm) :

DN	1/4"	3/8"	1/2"	3/4"	1"	1"1/4"	1"1/2"	2"	2"1/2"	3"	4"
Couple (Nm)	4	4	8	8	10	13	20	20	35	45	65

FLOW COEFFICIENT Kvs (M3 / h) :

DN	1/4"	3/8"	1/2"	3/4"	1"	1"1/4"	1"1/2"	2"	2"1/2"	3"	4"
Kvs (m3/h)	12.4	24.01	33	58.6	91.6	148.2	211.6	366.4	619.2	938	1465.6

STANDARDS :

- Fabrication according to ISO 9001 : 2008
- DIRECTIVE 97/23/CE : CE N° 0035
Risk Category III Module H
- Pressure tests according to EN 12266-1, rate A
- Threaded BSP cylindrical ends according to ISO 228-1
- Threaded NPT ends according to ANSI B1.20.1

ADVICE : Our opinion and our advice are not guaranteed and SFERACO shall not be liable for the consequences of damages. The customer must check the right choice of the products with the real service conditions.

3 PIECES STAINLESS STEEL BALL VALVE FEMALE NPT INITIAL RANGE

INSTALLATION AND MAINTENANCE

BEFORE INSTALLATION :

Pipe-line must be cleaned and free from residual of weldings, rubbish, shaving and every kind of extraneous materials.
Pipe-line must be perfectly aligned and their support properly dimensioned so that there's no external constraint.

Check to use a produce compatible to the services conditions for the sealing of the threaded types.
To tighten the ends, use the appropriate tool.
Use the right bolt tightening so that the ends won't be damaged.

The welding of the ends for the SW and the BW types, must be done with the central part removed.
A gauge can be used to have the good length and alignment between the ends.

INSTALLATION OF THE CENTRAL PART

During the installation of the central part, tighten bolts according to the table below. Tighten bolts in cross.

BOLT TIGHTENING TABLE (in Nm) :

DN	1/4"	3/8"	1/2"	3/4"	1"	1"1/4	1"1/2	2"	2"1/2	3"	4"
TORQUE (Nm)	4	4	8	8	10	13	20	20	35	45	65

CLEANING AND TESTS

Keep closed the valves during the cleaning operation so that there's no impurities between the ball and the body.

Tests under pressure must be done with a cleaned pipe-line.

Open partially the valve for tests. Pressure test do not exceed the valve specifications according to EN 12266-1.

MAINTENANCE

It's recommended to operate the valve twice (open and close) 1 to 2 times per year.

When intervention on the valve, be sure there's no pressure in the pipe-line, there's no fluid in it, and that it is isolated.
The temperature must be low enough to operate without risks.
If there's a corrosive fluid, inert installation before intervention.

When the valve is under pressure :
If there's a leakage between the body and the ends, tighten bolts according to the above table

If there's a leakage at the packing, tighten it slightly so that the leakage disappears.

MAINTENANCE OPERATION IN WORKSHOP

REPLACEMENT OF SEAT GASKETS AND PACKING.

The central part must be removed.

Turn the ball at 45° and removed the seat gaskets.

Operate the valve in closed position to removed the ball. Verify the surface of the ball has no impacts and no scores.

If there are important scores or impacts, replace the ball.

Clean inside the body valve and remove the impurities.

To replace the packing, remove the handle, unscrew the gland nut, extract the stem by the inside of the valve.

Clean the packing seat.

Reassemble thrust washer on stem, introduce stem by the inside of the valve, reassemble packing with packing nut, reassemble hand washer, hand nut and the handle.

Turn stem in closed position and insert the ball.

Then turn the ball in opened position and reassemble the seat.

Place the valve on the installation, tighten bolts according to the above table.

Then proceed to the tests in the same way that the first installation.