

FIRE SAFE 3 PIECES BALL VALVE FLANGED PN 40 EXCELLENCE RANGE

3 pieces stainless steel ball valve fully encapsulated bolts with full bore for Chemical industries, petrochemical industries, hydraulic installation, heating, water distribution, compressed air.

Ball valve with firesafe certificate ISO 10497 and API 607 to reduce risks in case of fire.

Graphite packing and PTFE filled with glass seat gasket on stem, PTFE filled with carbon seat.

Compatible with explosive atmosphere, ATEX Zone 1&21 and Zone 2&22 thanks to the antistatic device.

Handling with locking device, on request possible with handwheel or stem extension.

Thanks to the ISO 5211 plate, an actuator can be installed on the valve.



Certificate
3.1

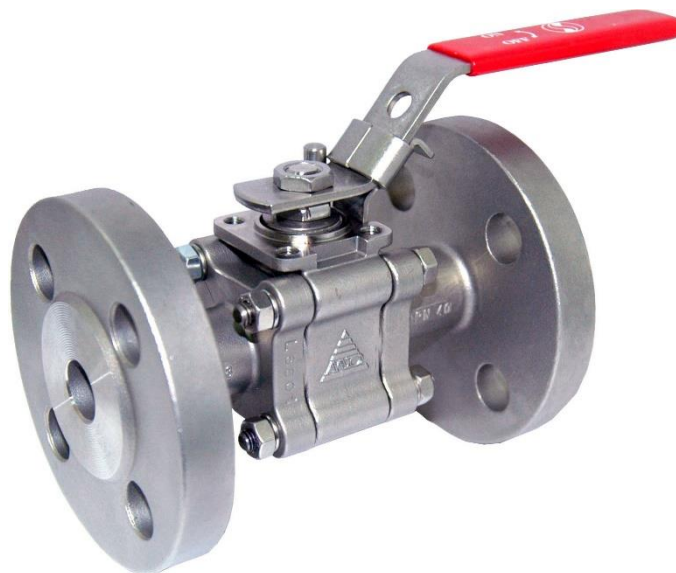

Size : DN 15 to 50

Connection : Flanges RF PN40

Min Temperature : -30°C

Max Temperature : +220°C

Max Pressure : 40 Bars

Specifications : Antistatic device, ATEX

ISO 5211 mounting pad

Anti blow-out stem, full bore

Fully encapsulated bolts

Fire safe ISO 10497 : 2010 and API 607 V.6

Materials : Stainless Steel EN 1.4408



FIRE SAFE 3 PIECES BALL VALVE FLANGED PN 40 EXCELLENCE RANGE

SPECIFICATIONS :

- Full bore
- Anti blow-out stem
- Special gland pack with elastic washer
- Double antistatic device (ball between body-stem and ball-stem)
- Fire safe according to ISO 10497:2010 and API 607 V.6
- Locking device
- Handwheel and stem extension (optional)
- ISO 5211 mounting pad
- Fully encapsulated bolts
- Flanges RF PN40

USE :

- Chemical and pharmaceutical industries, petrochemical industries, hydraulic installation, compressed air
- Steam : 18 bars maximum
- Min and max Temperatures Ts : -30°C to + 220°C
- Max Pressure Ps : 40 bars

FLOW COEFFICIENT Kvs (M3 / h) :

DN	15	20	25	32	40	50
Kvs (m3/h)	31.3	57.86	94.25	157.9	227.9	414.8

TORQUE VALUES (in Nm without safety coefficient) :

DN	15	20	25	32	40	50
Pressure (bar)						
Breaking torque	10	12	19.2	25	28.7	50
17	9.5	10	16	17	18	36
34	10	10	17	18	18	36

BOLT TIGHTENING TABLE (in Nm) :

DN	15	20	25	32	40	50
Torque (Nm)	9.8	22.07	22.07	39.2	39.2	58.8

FIRE SAFE 3 PIECES BALL VALVE FLANGED PN 40 EXCELLENCE RANGE

RANGE :

- 3 pieces stainless steel fire safe ball valve flanged PN40 Ref. **7034** from DN 15 to DN 50

CONNECTION :

- Flanges R.F. PN40

OPTIONS :

- AISI 304 handwheel Ref. **9830441-9830475**
- AISI 304 stem extension Ref. **9830471-9830474**

PRESSURE / TEMPERATURE GRAPH :

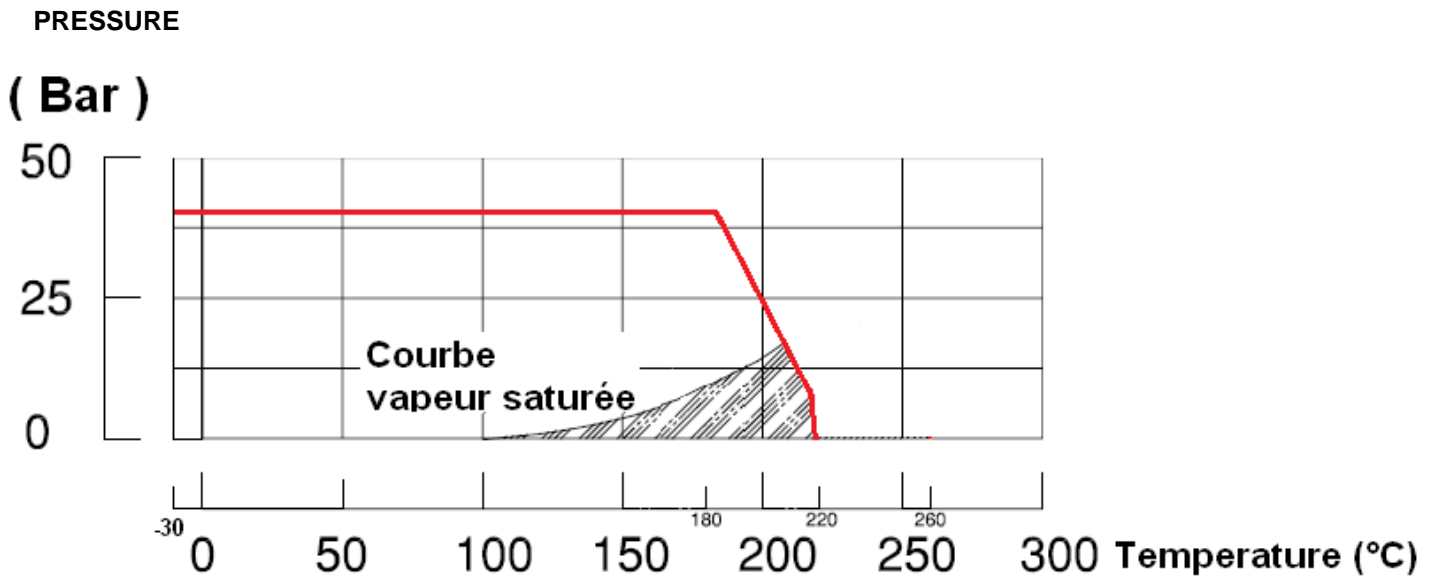

FIRE SAFE 3 PIECES BALL VALVE FLANGED PN 40 EXCELLENCE RANGE

MATERIALS :

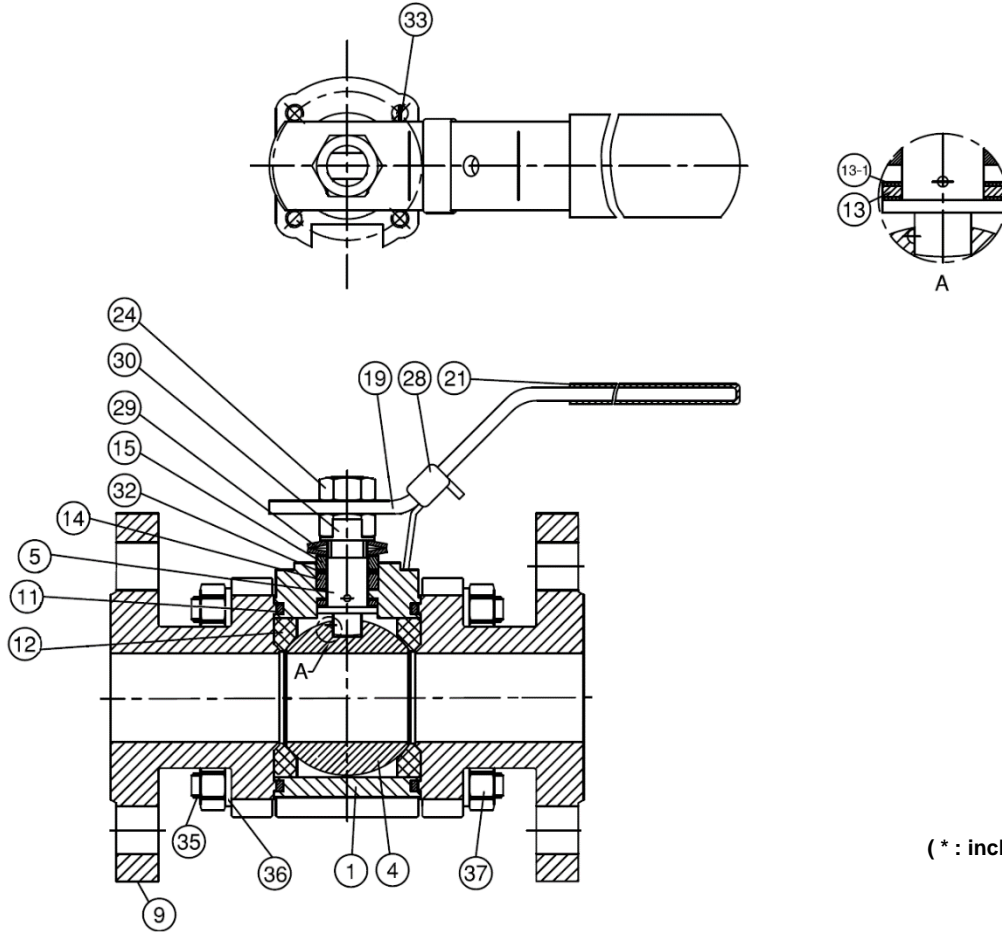

(* : included in gaskets kit)

Item	Designation	Materials
1	Body	EN 1.4408
4	Ball	ASTM A351 CF8M
5	Stem	AISI 316
9	Ends	EN 1.4408
11*	Body gasket	Graphite
12*	Seat	PTFE filled with 25% carbon
13*	Thrust washer	Graphite
13-1*	Thrust washer	PTFE with 15% Glass fiber
14*	Packing	Graphite
15	Gland bush	AISI 304
19	Handle	
21	Handle cover	Plastic
24	Handle nut	AISI 304
28	Locking device	
29	Elastic washer	AISI 301
30	Tab washer	AISI 304
32*	Packing follower	PTFE with 15% Glass fiber
33	Stop pin	AISI 304
35	Stud	ASTM A193 Gr.B8
36	Washer	AISI 304
37	Bolt nut	A194 Gr.8

FIRE SAFE 3 PIECES BALL VALVE FLANGED PN 40 EXCELLENCE RANGE

SIZE (in mm) :

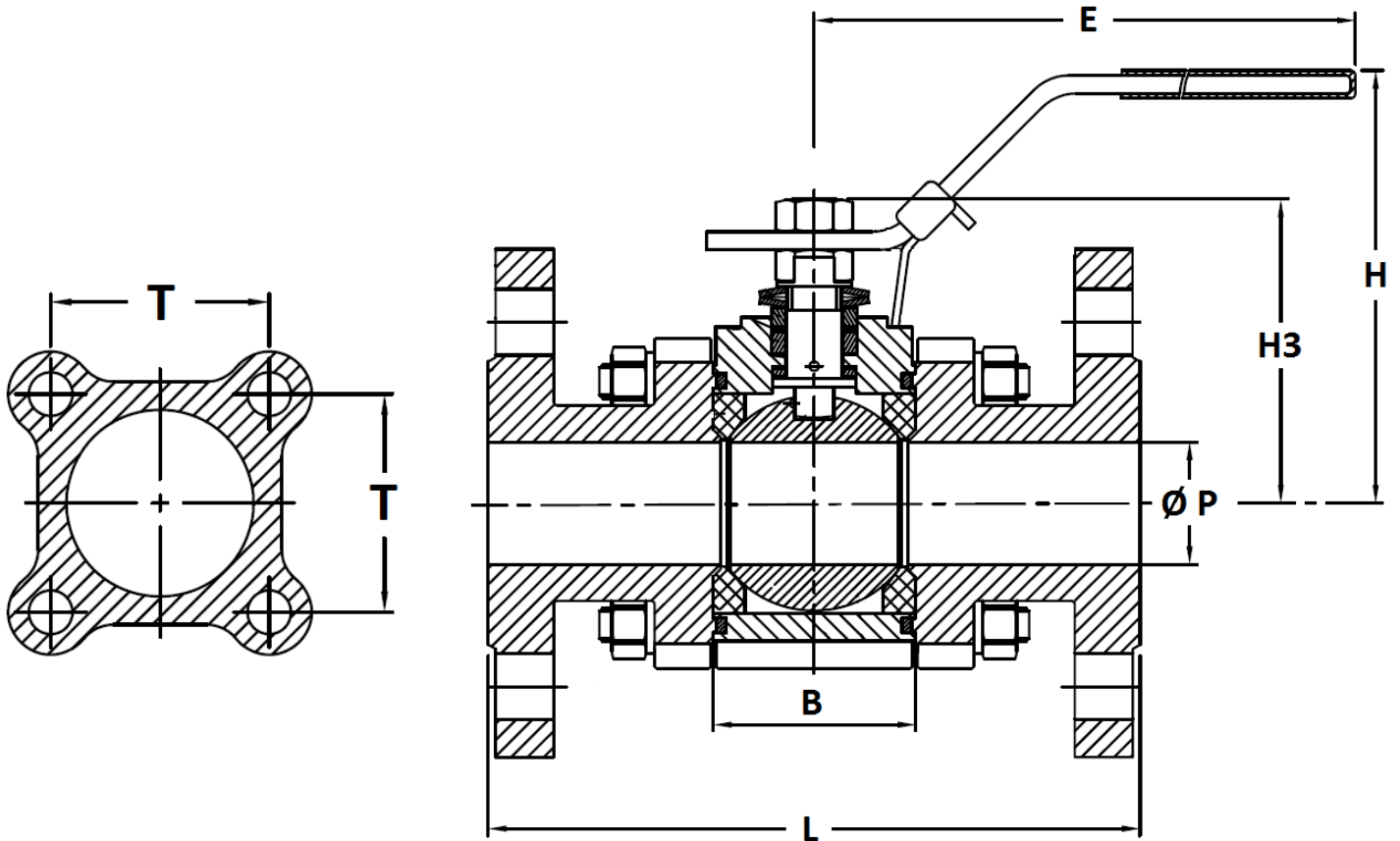

DN	15	20	25	32	40	50
Ø P	15	20	25	32	38	50
L	130	150	160	180	200	230
E	154.9	154.9	199.7	199.7	232.2	211
H	86.6	93.5	105.3	111.2	122.1	130
H3	46.1	50.9	61.4	66.8	80	99.4
B	24.5	31.4	41.3	48.4	56.3	72
T	35	41.3	48	56.2	63.6	79.2
Weight (Kg)	2.32	3.37	4.53	6.58	8.24	13
Ref.	703415	703420	703425	703432	703440	703450

FIRE SAFE 3 PIECES BALL VALVE FLANGED PN 40 EXCELLENCE RANGE

ISO 5211 MOUNTING PAD AND STEM SIZE (in mm) :

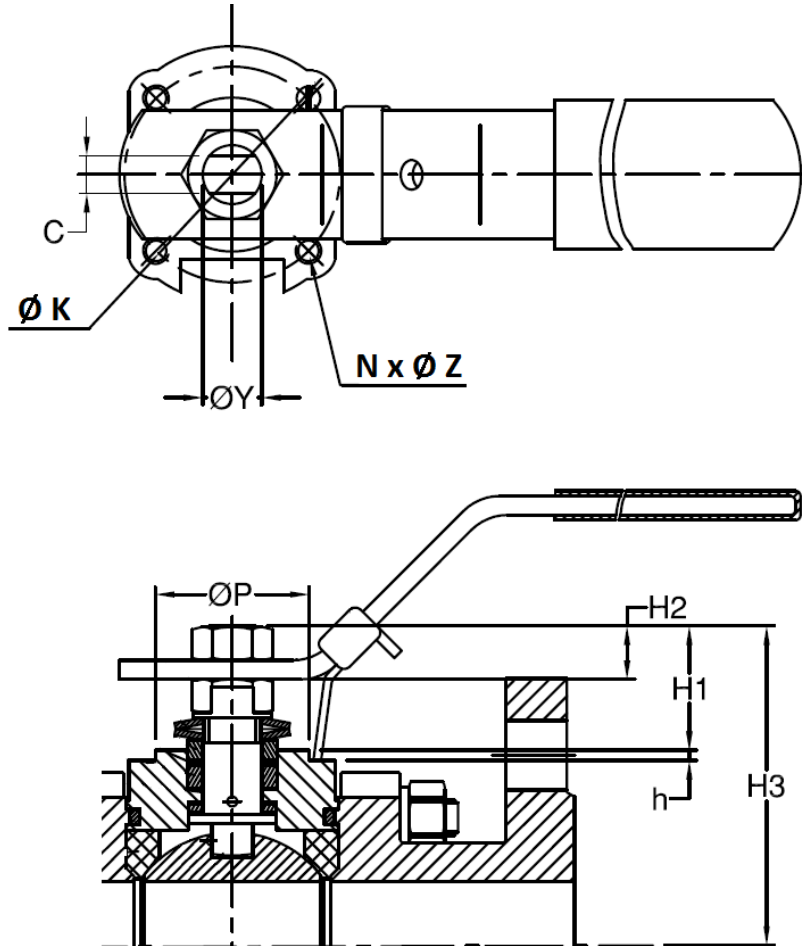

DN	15	20	25	32	40	50
H1	17.1	18.1	25.4	26.2	32.4	28.5
H2	11.1	9.1	13.1	12.6	14.9	15.5
H3	46.1	50.9	61.4	66.8	80	99.4
h	2	2	2	2	2,2	1,5
C	6,5	6,5	8	8	9,7	12
Ø Y	9,5	9,5	11,1	11,1	14,2	19
Ø P	25	25	30	30	35	55
Ø K	36	36	42	42	50	70
ISO	F03	F03	F04	F04	F05	F07
N x Ø Z	4x M5	4x M5	4x M5	4x M5	4 x M6	4 x M8

FIRE SAFE 3 PIECES BALL VALVE FLANGED PN 40 EXCELLENCE RANGE

FLANGES SIZE (in mm) :

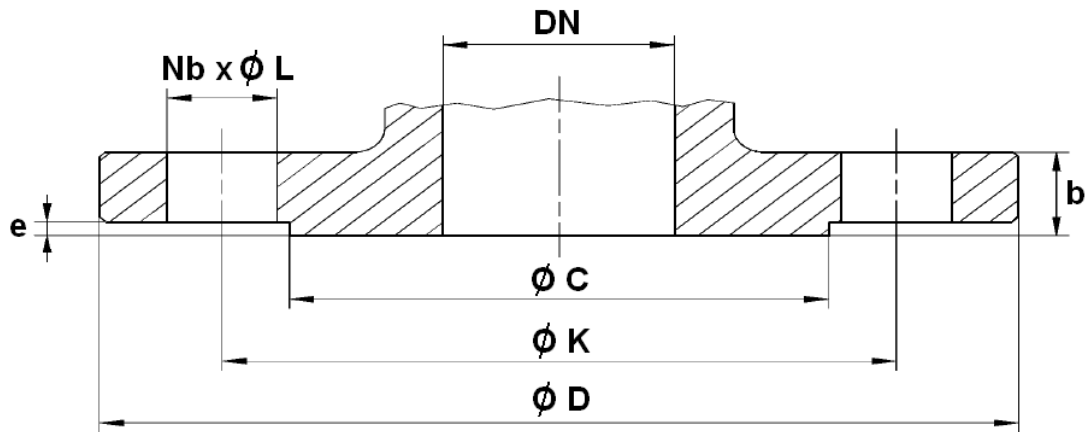

DN	15	20	25	32	40	50
Ø C	45	58	68	78	88	102
Ø D	95	105	115	140	150	165
Ø K	65	75	85	100	110	125
Nb x Ø L	4 x 14	4 x 14	4 x 14	4 x 18	4 x 18	4 x 18
b	16	18	18	18	18	20
e	2	2	2	2	3	3

FIRE SAFE 3 PIECES BALL VALVE FLANGED PN 40 EXCELLENCE RANGE

AISI 304 HANDWHEEL SIZE (in mm) :

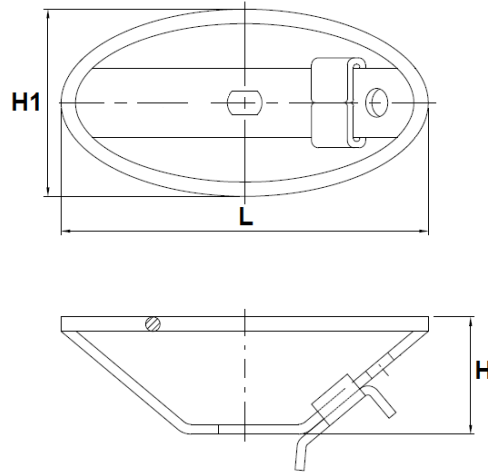

DN	15	20	25	32	40	50
L	116	116	130	130	147	194
H	35	35	40	40	43	51
H1	62	62	82	82	87	98
Weight (Kg)	0.12	0.12	0.18	0.18	0.22	0.34
Ref.	9830441	9830441	9830442	9830442	9830443	9830475

AISI 304 STEM EXTENTION SIZE (in mm) :

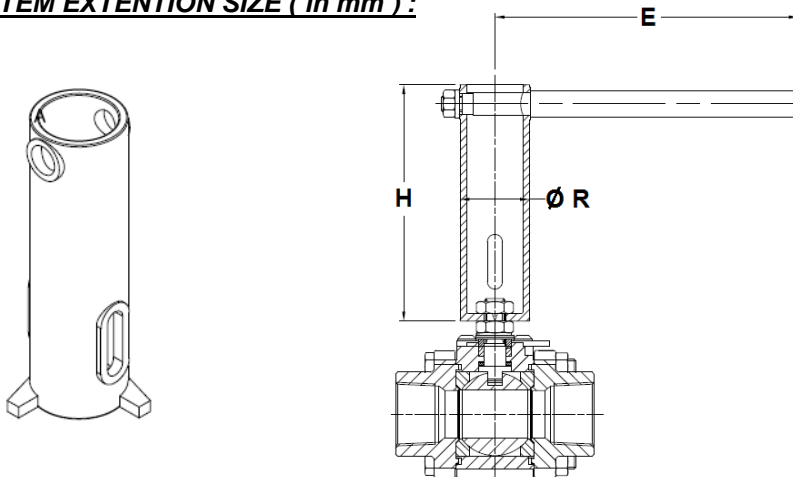

DN	15	20	25	32	40	50
H	125.5	125.5	125.5	125.5	127.5	127.5
E	126.5	126.5	161	161	194	198.5
Ø R	31	31	37	37	43	52
Ref.	9830471	9830471	9830472	9830472	9830473	9830474



FIRE SAFE 3 PIECES BALL VALVE FLANGED PN 40 EXCELLENCE RANGE

STANDARDS :

- Manufacturer certified ISO 9001 : 2015
- DIRECTIVE 2014/68/EU : For liquids and gas of Group 1
 - DN15-25 : Article 4, §3 (SEP), no CE marking
 - DN32-50 : Risk Category II, CE 0038 or CE 0343 marking
- Certificate 3.1 on request
- Construction according to EN 12516-1
- Designing according to ASME B16.34
- Pressure tests according to EN12266-1, rate A
- Fire safe according to ISO 10497:2010 and API 607 6th
- Flanges according to EN 1092-1 PN40
- ISO 5211 mounting pad
- Length according to EN 558 series 1 (NF 29335 DIN 3202 F1)
- ATEX Group II Category 2 G/2D Zone 1 & 21 Zone 2 & 22 (optional marking) according to directive 2014/34/EU

ADVICE : Our opinion and our advice are not guaranteed and SFERACO shall not be liable for the consequences of damages.
The customer must check the right choice of the products with the real service conditions.