

# Anti-rotation guide units Series 45

Suitable for cylinders:

- DIN/ISO 6432 (ø12, 16, 20, 25 mm)
- ISO 15552, previous DIN/ISO 6431 (ø32, 40, 50, 63, 80, 100 mm)

SERIES 45 GUIDE UNITS



- » To be used with VDMA/ISO cylinders
- » Available as ball bearing guide and self lubricating guide

Series 45 guide units can be used with all DIN/ISO 6432 cylinders of ø12 ÷ ø25 and ISO 15552, previous DIN/ISO 6431, cylinders of ø32 ÷ ø100.

They have been developed in order to prevent piston rod rotation and can support possible radial loads.

Series 45 guide units are available in three different models depending on the applicable loads. The UT and HT guides with crawling supports are self lubricating, while HB guides have a ball bush.

To ensure the right choice of the loads in relation to the stroke, please refer to the graphs. The shorter the stroke the higher will be the applicable loads.

## GENERAL DATA

<b>Type of construction</b>	U and H
<b>Operation</b>	Mod. 45NUT and 45NHT: without lubrication Mod. 45NHB requires lubrication according to DIN 51825 code KP2G-20
<b>Material</b>	body: anodized aluminium flexible coupling: stainless steel AISI 303 plate: anodized aluminium guided columns: rolled stainless steel AISI 420B (mod. 45NUT and 45NHT) - hardened steel C50 (Mod. 45NHB)
<b>Assembly</b>	by means of threaded holes
<b>Strokes min - max</b>	see diagrams
<b>Installation</b>	in any position

**CODING EXAMPLE**

<b>45</b>	<b>N</b>	<b>UT</b>	<b>050</b>	<b>A</b>	<b>0100</b>
<b>45</b>	SERIES				
<b>N</b>	VERSION N = standard				
<b>UT</b>	OPERATION UT = "U" self lubricating guide HT = "H" self lubricating guide HB = "H" ball guide				
<b>050</b>	BORE 016 = Ø 12-16 mm (available only in the UT version with "U" self lubricating guide) 020 = 20 mm 025 = 25 mm 032 = 32 mm 040 = 40 mm 050 = 50 mm 063 = 63 mm 080 = 80 mm 100 = 100 mm				
<b>A</b>	MATERIALS A = anodized aluminium body - stainless steel AISI 420B columns for 45UT and 45HT - hardened steel C50 columns for 45HB				
<b>0100</b>	STROKE in mm				

SERIES 45 GUIDE UNITS

**45NUT GUIDES - APPLICABLE LOADS DEPENDING ON PROJECTION - GRAPH No 1**

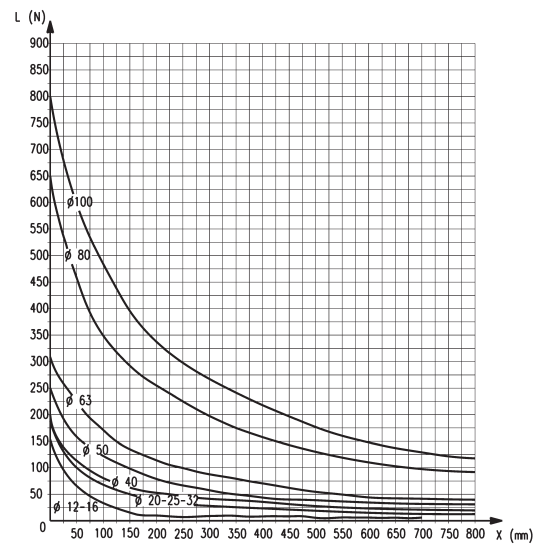
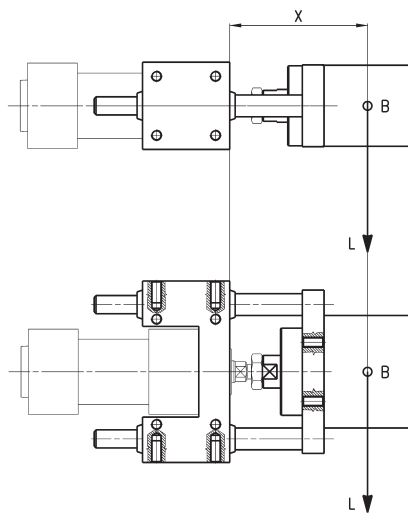

B = centre of gravity for applied load  
 L = load  
 X = fixed projection + stroke  
 fixed projection = distance to the centre of gravity

Guide "U" moving on bush (45NUT)

**45NHB GUIDES - APPLICABLE LOADS DEPENDING ON PROJECTION - GRAPH No 2**

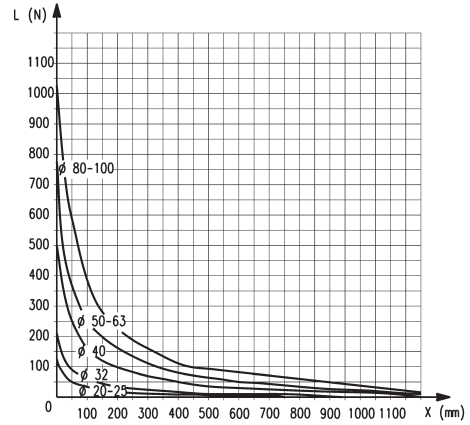
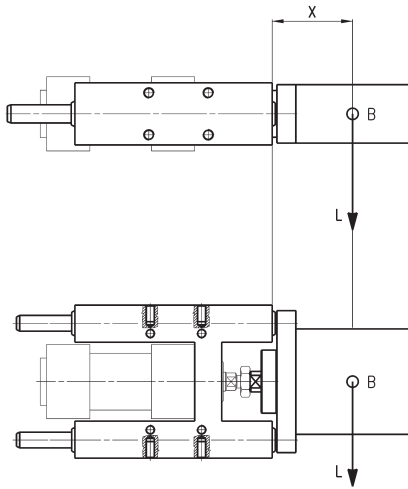

B = centre of gravity for applied load  
L = load  
X = fixed projection + stroke  
fixed projection = distance to the centre of gravity

Guide "HB" with linear ball bearing (45NHB)

**45NHT GUIDES - APPLICABLE LOADS DEPENDING ON PROJECTION - GRAPH No 3**

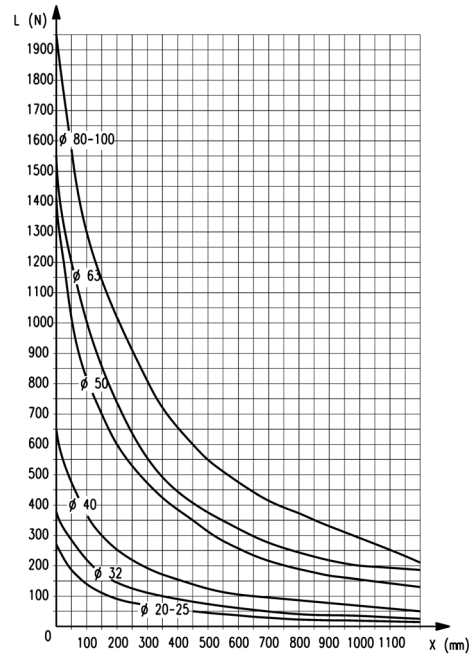
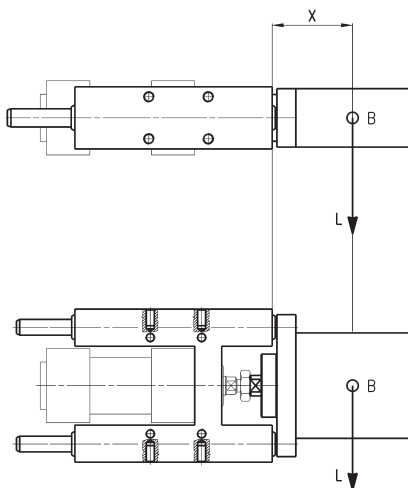

B = centre of gravity for applied load  
L = load  
X = fixed projection + stroke  
fixed projection = distance to the centre of gravity

Guide "HT" moving on bush (45NHT)

### Guides Mod. 45NUT for cylinders Series 16, 24, 25



Suitable for cylinders Series 16, 24 and 25 DIN/ISO 6432,  $\varnothing$  12 and 16. These guides do not need lubrication. For applicable loads see graph 1.

Cylinders  $\varnothing$  12 and  $\varnothing$  16 use the same guides.

Supplied with:  
1x fixing nut.

Draw note:  
+ = add the stroke

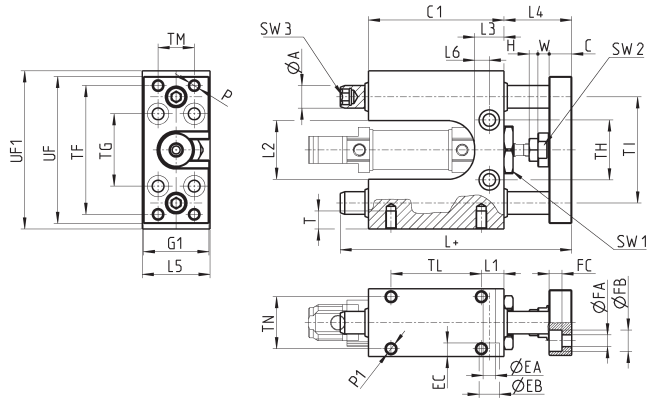

DIMENSIONS																																		
$\varnothing$	TF	TG	TH	TI	TM	TL	TN	UF1	UF	G1	$\varnothing$ A	C1	H	W	C	L	L1	L2	L3	L4	L5	L6	P	P1	T	$\varnothing$ EA	$\varnothing$ EB	EC	$\varnothing$ FA	$\varnothing$ FB	FC	SW1	SW2	SW3
12	57	32	26,5	47	16	40	23	70	65	29	10	60	4	5	10	102,5	10	26	13	30	30	6,5	M5	M5	8	5,5	9	5,7	5,5	9,5	5,7	21	13	6
16	57	32	26,5	47	16	40	23	70	65	29	10	60	4	5	10	102,5	10	26	13	30	30	6,5	M5	M5	8	5,5	9	5,7	5,5	9,5	5,7	21	13	6

### Guides Mod. 45NUT for cylinders Series 24, 25



Suitable for cylinders Series 24 and 25 DIN/ISO 6432,  $\varnothing$  20 and 25. These guides do not need lubrication.

For applicable loads see graph 1.

Supplied with:  
1x fixing nut.

Draw note:  
+ = add the stroke

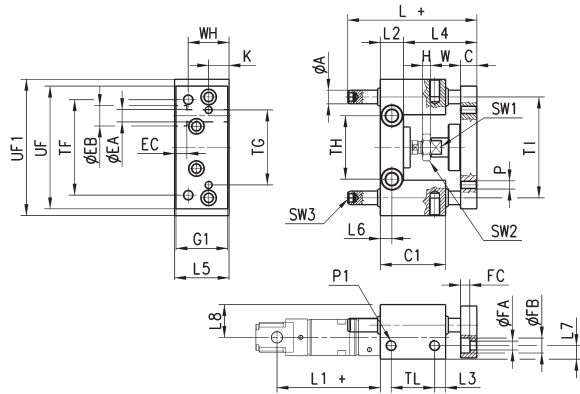

DIMENSIONS																																		
$\varnothing$	TF	TG	TH	TI	TL	UF1	UF	G1	$\varnothing$ A	WH	C1	H	W	C	K	L	L1	L2	L3	L4	L5	L6	L7	L8	P	P1	$\varnothing$ EA	$\varnothing$ EB	EC	$\varnothing$ FA	$\varnothing$ FB	FC	SW1	SW2
20	70	55	46,5	74	32	100	90	38	10	30	48	4	22	12	15	77	71	17	8	48+2	40	8,5	10	24	M6	M8	9	15	9	6,5	11	6,8	13	13
25	70	55	46,5	74	32	100	90	38	10	30	48	6	22	12	15	77	76	17	8	48+2	40	8,5	10	24	M6	M8	9	15	9	6,5	11	6,8	13	17

### Guides Mod. 45NHT for cylinders Series 24, 25



Suitable for cylinders Series 24 and 25 DIN/ISO 6432,  $\varnothing$  20 and 25. These guides do not need lubrication.

For applicable loads see graph 3.

Supplied with:  
1x fixing nut.

Draw note:  
+ = add the stroke

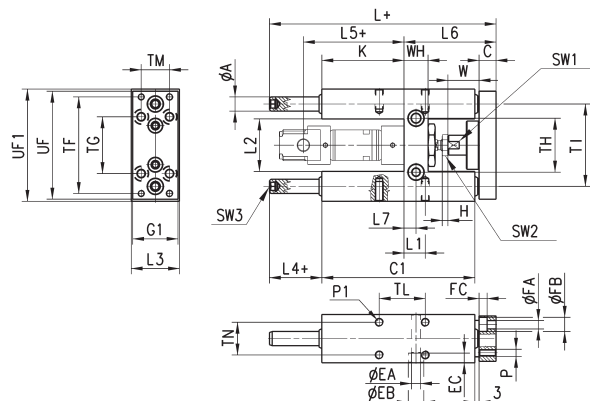

DIMENSIONS																																					
$\varnothing$	TF	TG	TH	TI	TL	TM	TN	UF	G1	UF1	$\varnothing$ A	WH	C1	H	W	C	K	L	L1	L2	L3	L4	L5	L6	L7	P	P1	T	$\varnothing$ EA	$\varnothing$ EB	EC	$\varnothing$ FA	$\varnothing$ FB	FC	SW1	SW2	SW3
20	68	40	38	58	32,5	20	23	76	32	79	10	17	108	4	22	12	58	160	15	37	34	37	71	65	8,5	M5	M6	14	6,5	11	6,8	5,5	10	5,7	13	6	
25	68	40	38	58	32,5	20	23	76	32	79	10	17	108	6	17	12	58	160	15	37	34	37	76	65	8,5	M5	M6	14	6,5	11	6,8	5,5	10	5,7	13	17	6

### Guides Mod. 45NHB for cylinders Series 24, 25



Suitable for cylinders Series 24 and 25 DIN/ISO 6432,  $\varnothing$  20 and 25.  
To lubricate these guides, use the special lubricator. For applicable loads see graph No 2.

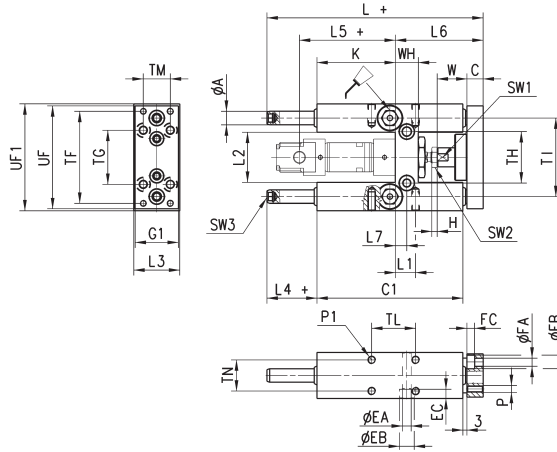

Supplied with:  
1x fixing nut.

Draw note:  
+ = add the stroke

**DIMENSIONS**

$\varnothing$	TF	TG	TH	T1	TL	TM	TN	UF	G1	UF1	A	WH	C1	H	W	C	K	L	L1	L2	L3	L4	L5	L6	L7	P	P1	T	$\varnothing$ EA	$\varnothing$ EB	EC	$\varnothing$ FA	$\varnothing$ FB	FC	SW1	SW2	SW3
20	68	40	38	58	32,5	20	23	76	32	79	10	17	108	4	22	12	58	160	15	37	34	37	71	65	8,5	M5	M6	14	6,5	11	6,8	5,5	10	5,7	13	13	6
25	68	40	38	58	32,5	20	23	76	32	79	10	17	108	6	17	12	58	160	15	37	34	37	76	65	8,5	M5	M6	14	6,5	11	6,8	5,5	10	5,7	13	17	6

### Guides Mod. 45NUT for cylinders Series 61, 63



Suitable for ISO 15552 (previous DIN/ISO 6431) cylinders Series 61, 63,  $\varnothing$  32, 40, 50, 63, 80 and 100. These guides do not need lubrication. For applicable loads see graph No 1.

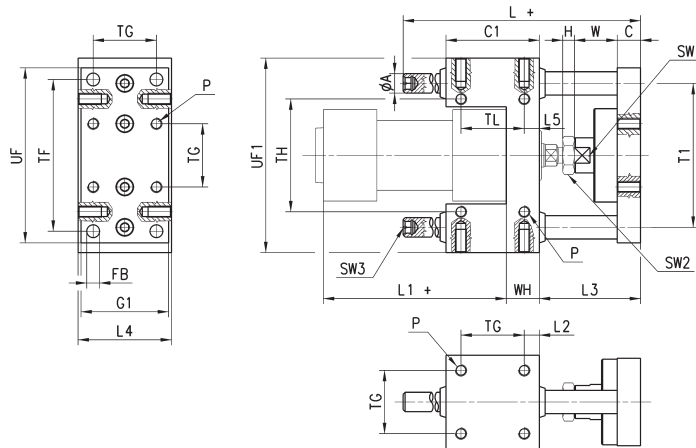

Supplied with:  
4x fixing screws.

Draw note:  
+ = add the stroke

**DIMENSIONS**

$\varnothing$	TF	TG	TH	$\varnothing$ A	T1	P	FB	UF	G1	UF1	L	C1	H	W	C	L1	WH	L2	L3	L4	L5	TL	SW1	SW2	SW3
32	78	32,5	58	12	74	M6	6,6	90	45	100	106	48	6	22	12	94	17	7,8	52	48	7,8	32,5	15	17	6
40	84	38	64	12	80	M6	6,6	100	50	106	117	58	7	22	12	105	21	10	53	56	10	38	15	19	6
50	100	46,5	80	16	96	M8	9	120	60	125	129	59	8	26	15	106	25	6,2	64	66	6,3	46,5	22	24	6
63	105	56,5	95	16	104	M8	9	125	70	132	146	76	8	26	15	121	25	9,8	64	76	9,8	56,5	22	24	6
80	130	72	130	20	130	M10	11	155	90	165	170	90	9	32	16	128	34	9	72	98	20	50	27	30	6
100	150	89	150	20	150	M10	11	175	110	185	190	110	9	32	16	138	39	10,5	72	118	20	70	27	30	6

### Guides Mod. 45NHT for cylinders Series 61, 63



Suitable for ISO 15552 (previous DIN/ISO 6431) cylinders Series 61, 63,  $\varnothing$  32, 40, 50, 63, 80 and 100. These guides do not need lubrication. For applicable loads see graph No 3.

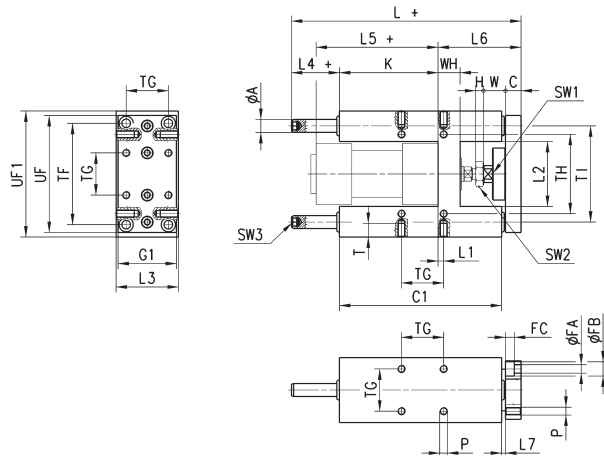

Supplied with:  
4x fixing screws.

Draw note:  
+ = add the stroke

DIMENSIONS																														
$\varnothing$	TF	TG	TH	TI	UF	G1	UF1	$\varnothing$ A	WH	C1	H	W	C	K	L	L1	L2	L3	L4	L5	L6	L7	P	T	$\varnothing$ FA	$\varnothing$ FB	FC	SW1	SW2	SW3
32	78	32.5	61	74	90	45	97	12	17	125	6	17	12	76	177	4.3	50.2	50	37	94	64	3	M6	14	6.5	11	6.8	13	17	6
40	84	38	69	87	110	54	115	16	21	140	7	22	12	81	192	11	58.2	58	37	105	74	3	M6	14	6.5	11	6.8	15	19	6
50	100	46.5	85	104	130	63	137	20	26	149	8	26	15	78.5	205	19.8	70.2	70	37.5	106	89	3	M8	16	9	15	9	22	24	6
63	105	56.5	100	119	145	80	152	20	26	178	8	26	15	111	237	15.3	85.2	85	37	121	89	7	M8	16	9	15	9	22	24	6
80	130	72	130	148	180	100	189	25	34	195	9	32	20	128	280	21	105.4	105	42	128	110	23	M10	20	11	18	11	27	30	6
100	150	89	150	172	200	120	213	25	39	220	9	32	20	128	280	24.5	130.4	130	37	138	115	3	M10	20	11	18	11	27	30	6

### Guides Mod. 45NHB for cylinders Series 61, 63



Suitable for ISO 15552 (previous DIN/ISO 6431) cylinders Series 61, 63, 6E,  $\varnothing$  32, 40, 50, 63, 80 and 100. To lubricate these guides, use the special lubricator. For applicable loads see graph No 2.

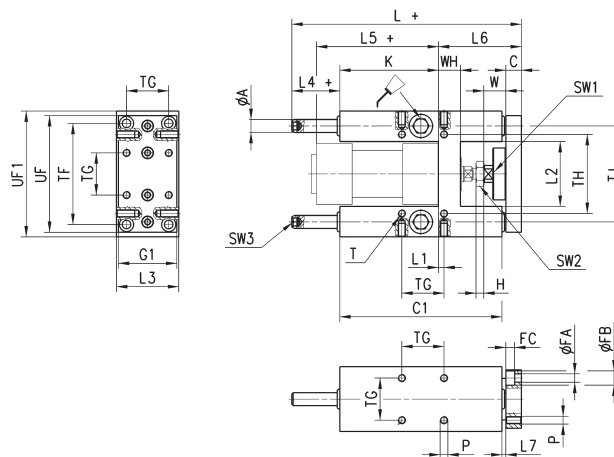

Supplied with:  
4x fixing screws.

Draw note:  
+ = add the stroke

DIMENSIONS																														
$\varnothing$	TF	TG	TH	TI	UF	G1	UF1	$\varnothing$ A	WH	C1	H	W	C	K	L	L1	L2	L3	L4	L5	L6	L7	P	T	$\varnothing$ FA	$\varnothing$ FB	FC	SW1	SW2	SW3
32	78	32.5	61	74	90	45	97	12	17	125	6	17	12	76	177	4.3	50.2	50	37	94	64	3	M6	14	6.5	11	6.8	13	17	6
40	84	38	69	87	110	54	115	16	21	140	7	22	12	81	192	11	58.2	58	37	105	74	3	M6	14	6.5	11	6.8	15	19	6
50	100	46.5	85	104	130	63	137	20	26	149	8	26	15	78.5	237	19.8	70.2	70	37.5	106	89	3	M8	16	9	15	9	22	24	6
63	105	56.5	100	119	145	80	152	20	26	178	8	26	15	111	237	15.3	85.2	85	37	121	89	7	M8	16	9	15	9	22	24	6
80	130	72	130	148	180	100	189	25	34	195	9	32	20	128	280	21	105.4	105	42	128	110	23	M10	20	11	18	11	27	30	6
100	150	89	150	172	200	120	213	25	39	220	9	32	20	128	280	24.5	130.4	130	37	138	115	3	M10	20	11	18	11	27	30	6