

SUMMARY Skillair®

- GENERAL TECHNICAL DATA Skillair®

C3.4



- Skillair® FILTER

C3.7



- Skillair® DEPURATOR

C3.11



- Skillair® ACTIVE CARBON FILTER

C3.14



- DIAPHRAGM DRIER SERIES DRY 100 Skillair®

C3.17



- Skillair® REGULATOR

C3.20



- Skillair® 100 IN-SERIES REGULATOR

C3.24



- Skillair® PADLOCKABLE REGULATOR

C3.25



- Skillair® PILOT REGULATOR

C3.27



- Skillair® PILOT PADLOCKABLE REGULATOR

C3.29



- Skillair® 300 PILOT OPERATED REGULATOR

C3.30



- Skillair® FILTER REGULATOR

C3.31



- Skillair® LUBRICATOR

C3.34

	● Skillair® SHUT-OFF VALVE	 C3.38
	● Skillair® PROGRESSIVE START VALVE	 C3.43
	● Skillair® PROGRESSIVE STARTER	 C3.45
	● Skillair® AIR TAKE-OFF	 C3.49
	● Skillair® PRESSURE SWITCHES	 C3.50
	● Skillair® SUB-BASE AND ADAPTER BASE	 C3.52
	● FIL + REG + LUB Skillair®	 C3.54
	● FR + LUB Skillair®	 C3.56
	● V3V + FR + LUB Skillair®	 C3.58
	● FIL + LUB Skillair®	 C3.60
	● FIL + DEP Skillair®	 C3.62
	● Skillair® ACCESSORIES	 C3.64
	● Skillair® SPARES PARTS	 C3.65

GENERAL TECHNICAL DATA Skillair®

The superior technology of Skillair® FRL units is the expression of Metal Work innovation. The FRL system is the brainchild of a joint study by Metal Work engineers and researchers from the Department of Mechanics in Turin. The integration of metal alloys and super-resistant techno-polymers is the result of co-operation between CESAP (European Centre for the Development of Plastic Applications) and leading international companies such as Du Pont, EMS Chemie and Hoechst. The installation of advanced processing and quality control systems guarantees the reliability of Skillair® FRLs.

Technical features

The Skillair® units incorporate very interesting technological features:

- **Compactness:** with the same flow capacity our unit is one of the smallest on the market.
- **Modularity:** various elements such as filters, reducers, lubricators, 3-way valves, progressive actuators and air take-offs can be combined at will. With the modular system the FRL units can be removed without disturbing the pipes.
- **Easy maintenance:** Any of the elements or the entire unit can be removed without disturbing the remaining part or pipes.

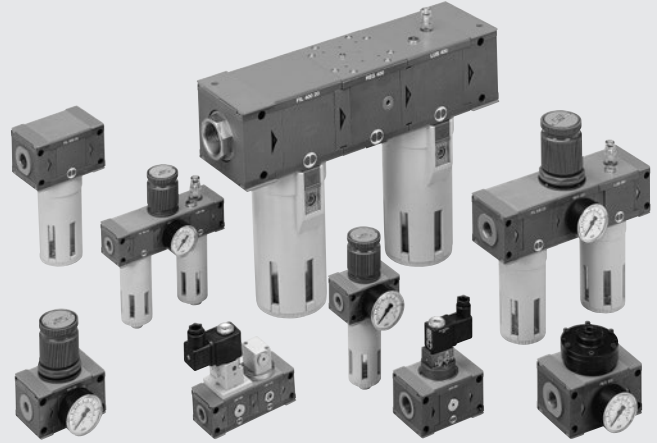

UNITS

GENERAL TECHNICAL DATA Skillair®

TECHNICAL DATA	SK 100		SK 200			SK 300			SK 400			
	1/4"	3/8"	1/4"	3/8"	1/2"	1/2"	3/4"	1"	1"	1 1/4"	1 1/2"	2"
Threaded port												
Degree of filtration	µm											
Degree of purification	µm											
Setting range	bar											
Max. input pressure	MPa											
	bar											
	psi											
Flow rate at 6.3 bar (0.63 MPa to 91 psi)	NI/min											
ΔP 0.5 bar (0.05 MPa to 7 psi)												
Fluid												
Temperature range at 1 MPa; 10 bar; 145 psi	°C											
	°F											
Elements comprising the range	Filter, Depurator, Regulator, Pilot operated regulator, In-series Regulator, Filter-regulator, Lubricator with various lubricant filling systems, Circuit Shut-off Valve, Progressive Actuator.											
Compatibility with oils	See chapter Z1											

Skillair® MODULARITY

The FRL units can be removed from the system without disturbing the pipes. This can be done with a single element or with the entire system. Assemble the unit so that the air flows in the direction marked by the arrows.

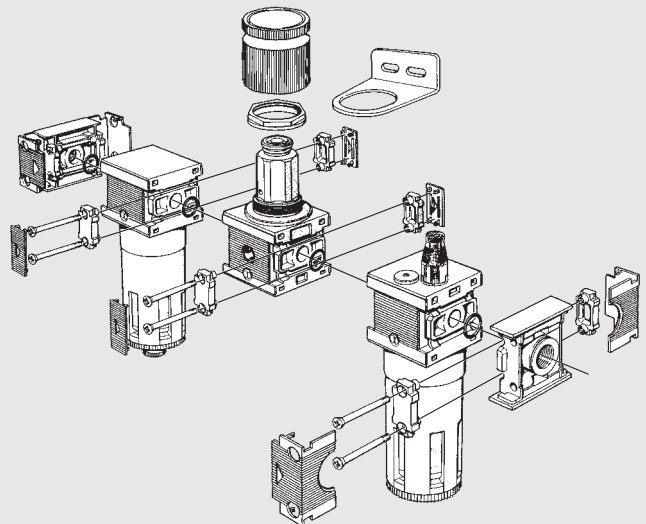

DISASSEMBLING THE UNIT – WALL FIXING

How to disassemble Skillair® end plates:

- Remove the plate **A**.
- Unscrew the screws and remove the cams **B** to disassemble the unit.
- Screws to fix the end plates to the wall **C**:
 Series 100: M4x50
 Series 200: M5x60
 Series 300: M5x70
 Series 400: M6x110

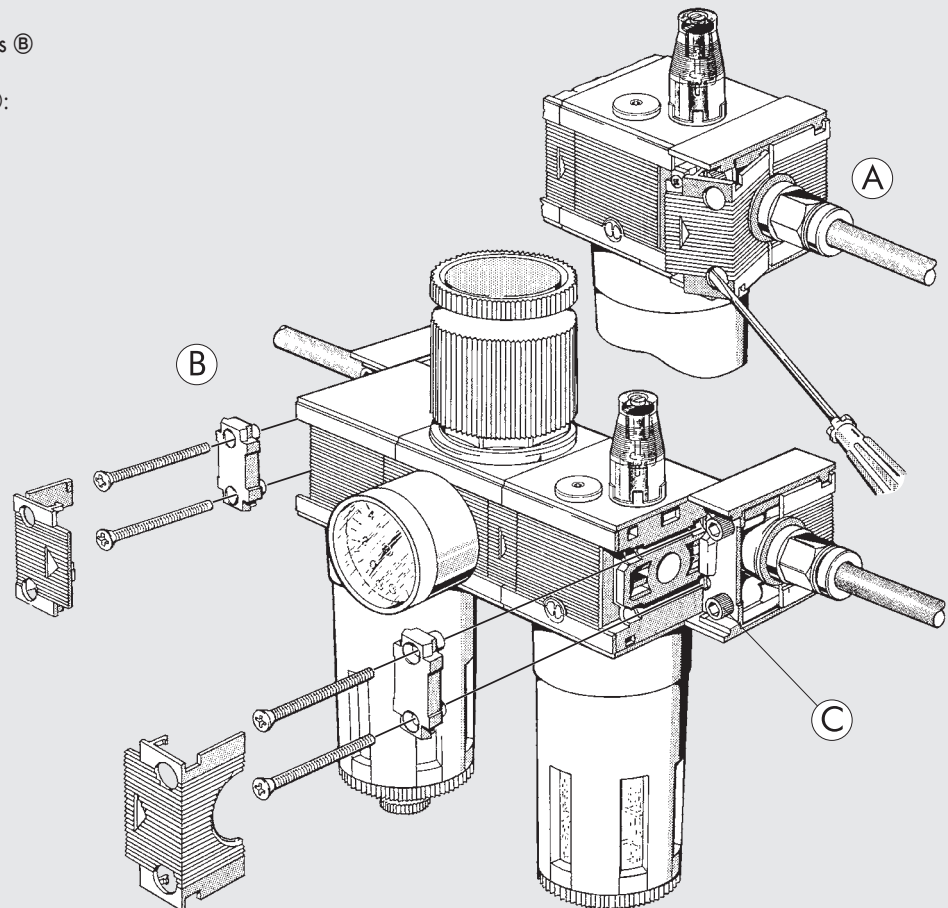

Skillair® 400 - ROTARY SLIDING JOINT

The series 400 comes with a patented system with a rotary sliding end joint to allow the unit to be adapted to the pipe cutting distance. For correct assembly and disassembly, loosen the screw in the end plate before screwing in or unscrewing the bush.

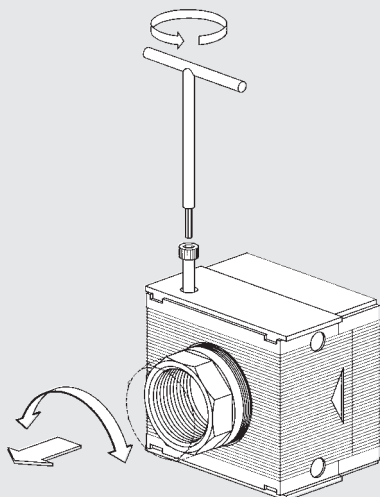

CLEANING AND/OR REPLACING THE FILTER ELEMENTS

Before unscrewing the bowl to replace the filter elements, check that the line is no longer pressurized.
 Replace as shown in the diagram.

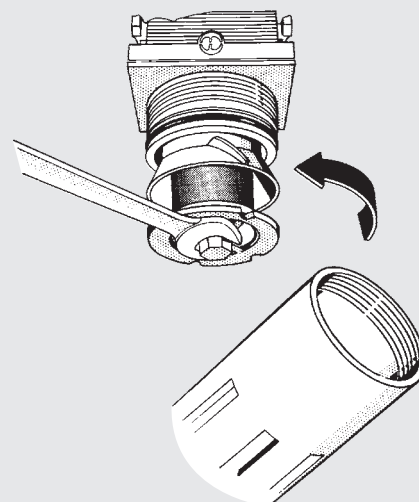

GENERAL RULES FOR USE AND MAINTENANCE

MOUNTING THE PRESSURE GAUGE

- ① Do not use a spanner.
- ② The gauge must be mounted by hand. Use liquid sealants only. Do not use Teflon.

①

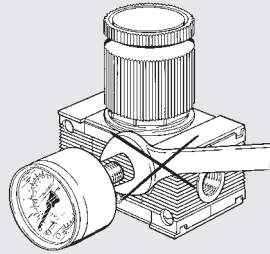

②

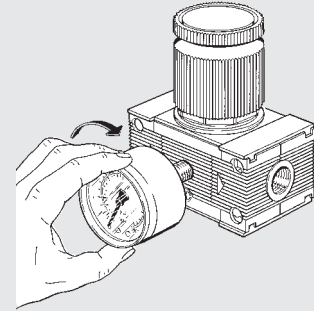

SETTING THE PRESSURE

- ③ **N.B.: the pressure in standard regulators must always be set upwards.** Before setting the pressure, check that the knob is raised.
- ④ When the required pressure has been reached, press the knob downwards.

③

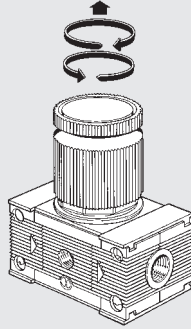

④

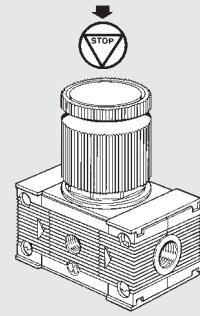

MOUNTING THE REGULATOR AND FILTER-REGULATOR

- ⑤ Panel mounting: remove the knob and lock the regulator with the ring nut.
- ⑥ Wall mounting: use a suitable bracket (see Skillair® accessories).

⑤

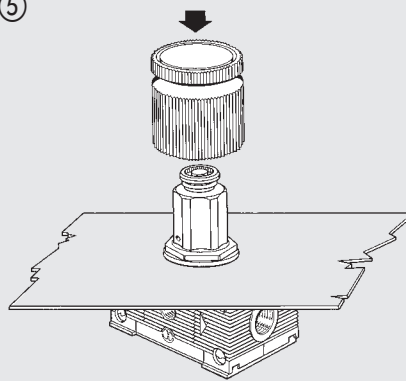

⑥

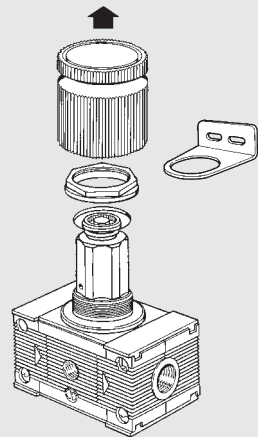

SEMI-AUTO CONDENSATE DRAIN FOR FILTER, FILTER-REGULATOR AND DEPURATOR

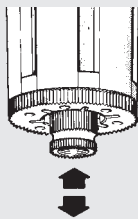

The semi-auto condensate drain is the normally open type. When there is pressure in the bowl, the drain closes. When there is no pressure in the bowl, it opens and the condensate drains out.

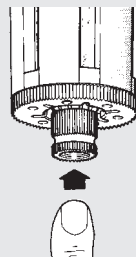

If necessary, it is possible to drain the condensate whilst the bowl is pressurised. The simple manual operation of "pushing up the valve" will allow the condensate to drain.

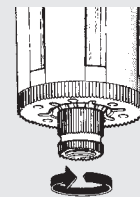

When rotating the button clockwise, the valve becomes in locked position, and can only work when the button is returned to the central position.

Skillair® FILTER



The Job of the filter is to remove any solid or liquid impurities from the air generated by the compressor.
 Incoming air is rotated by the centrifuge unit. The heaviest liquid and solid particles are projected against the walls of the container and forced to adhere to it. As they accumulate they form drops that deposit on the bottom by gravity. The remaining solid particles are held back by the porous element depending on the filtering threshold.
 The accumulated condensate is drained out through the drain - automatically when there is no pressure in the filter, or by hand pressing the button.
 An automatic drain is available. It automatically eliminates condensate from the container whenever necessary, whatever the pressure.
 The transparent windows allow to view the level of condensation at 360°.



TECHNICAL DATA	FIL 100		FIL 200			FIL 300			FIL 400			
	1/4"	3/8"	1/4"	3/8"	1/2"	1/2"	3/4"	1"	1"	1 1/4"	1 1/2"	2"
Threaded port												
Degree of filtration	µm 5 - 20 - 50		5 - 20 - 50			5 - 20 - 50			5 - 20 - 50			
Max. input pressure	MPa 1.5		1.3			1.3			1.3		1.3	
	bar 15		13			13			13		13	
	psi 217		188			188			188		188	
Flow rate at 6.3 bar (0.63 MPa to 91 psi)	NL/min 1400		2400			3800			16500		20000	
ΔP 0.5 bar (0.05 MPa to 7 psi)	scfm 50		85			135			590		710	
Flow rate at 6.3 bar (0.63 MPa to 91 psi)	NL/min 2000		3100			5300			-		-	
ΔP 1 bar (0.1 MPa to 14 psi)	scfm 71		110			188			-		-	
Max temperature at 1 MPa; 10 bar; 145 psi	°C 50		50			50			50		50	
	°F 122		122			122			122		122	
Weight	kg 0.4		0.7			1.4			5.2		6	
Wall fixing screws	M4 x 50		M5 x 60			M5 x 70			M6 x 110		M6 x 110	
Bowl capacity	cm³ 22		45			75			270		270	
Mounting position	Vertical		Vertical			Vertical			Vertical		Vertical	
Drain	RMSA - SAC		RMSA - SAC - RA			RMSA - RA			RMSA - RA		RMSA - RA	
	RMSA: drain with manual condensate discharge and automatic discharge at zero pressure RA: automatic drain with condensate discharge, independent of pressure and flow rate. Version conveys the draining by inserting the pipe having internal diameter 6 mm in the lower port. SAC: automatic drain with condensate discharge. Operates by pressure drop – requires variable air take-offs. Compressed air.											
Fluid												
Notes on use	The maximum inlet pressure for the version with RA automatic condensate drainage must not exceed 10 bar.											

UNITS
Skillair® FILTER

COMPONENTS FIL 100 - 200 - 300

- ① Technopolymer body
- ② Zamak end plate
- ③ Technopolymer centrifuge
- ④ Bowl: technopolymer for FIL 100 and FIL 200, metal for FIL 300
- ⑤ Technopolymer baffle
- ⑥ Sintered HDPE filter cartridge
- ⑦ Technopolymer screen
- ⑧ Clear technopolymer glass
- ⑨ NBR gaskets
- ⑩ Drain (RMSA)

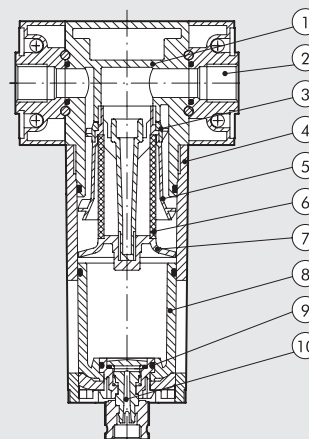

COMPONENTS FIL 400

- ① Aluminium body
- ② Aluminium end plate
- ③ OT58 brass retaining ring
- ④ Anodized aluminium threaded bush, axial adjustment
- ⑤ Technopolymer centrifuge
- ⑥ Aluminium bowl
- ⑦ Sintered bronze filter cartridge
- ⑧ Aluminium screen
- ⑨ Clear technopolymer glass
- ⑩ Technopolymer plug
- ⑪ Drain (RMSA)
- ⑫ NBR gaskets

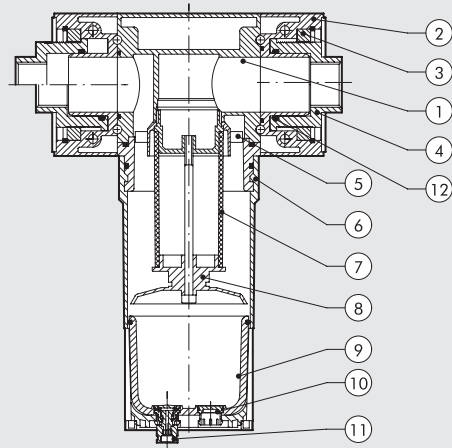

FLOW CHARTS

FIL 100 1/4 - 3/8

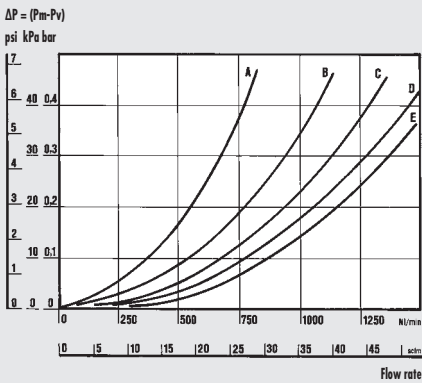

FIL 200 1/4 - 3/8 - 1/2

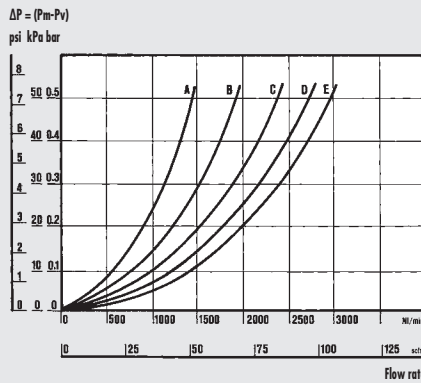

FIL 300 1/2 - 3/4 - 1

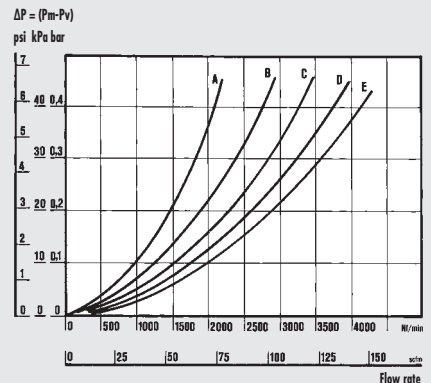

FIL 400 1"

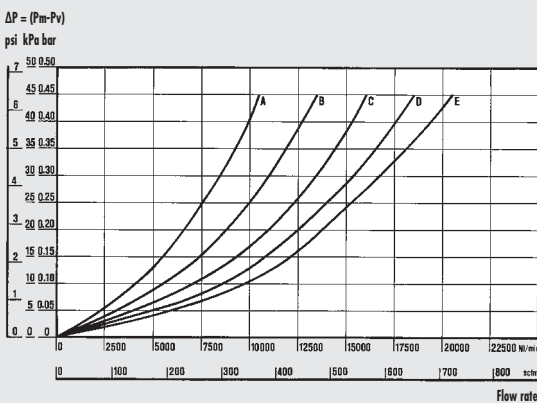

FIL 400 2"

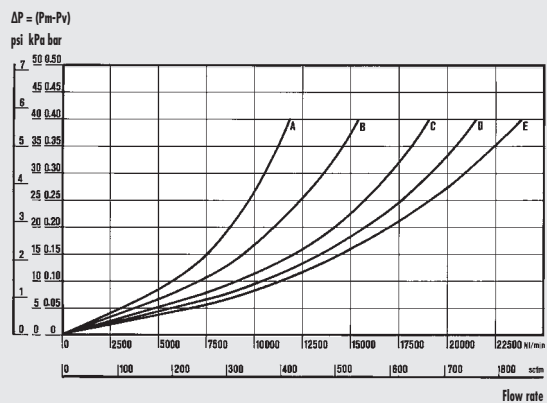

• Flow tests carried out at the Department of Mechanics, Turin Polytechnic, using the computerized test bench following CETOP RP50R recommendations (ISO DIS 6358-2-approved) with ISO 5167 diaphragm gauge.

- (A) = 2 bar - 0.2 MPa - 29 psi
- (B) = 4 bar - 0.4 MPa - 58 psi
- (C) = 6 bar - 0.6 MPa - 87 psi
- (D) = 8 bar - 0.8 MPa - 116 psi
- (E) = 10 bar - 1 MPa - 145 psi

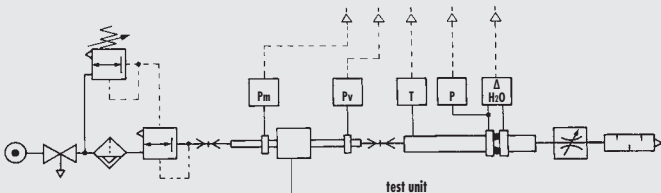

DIMENSIONS

100 - 200 - 300

400

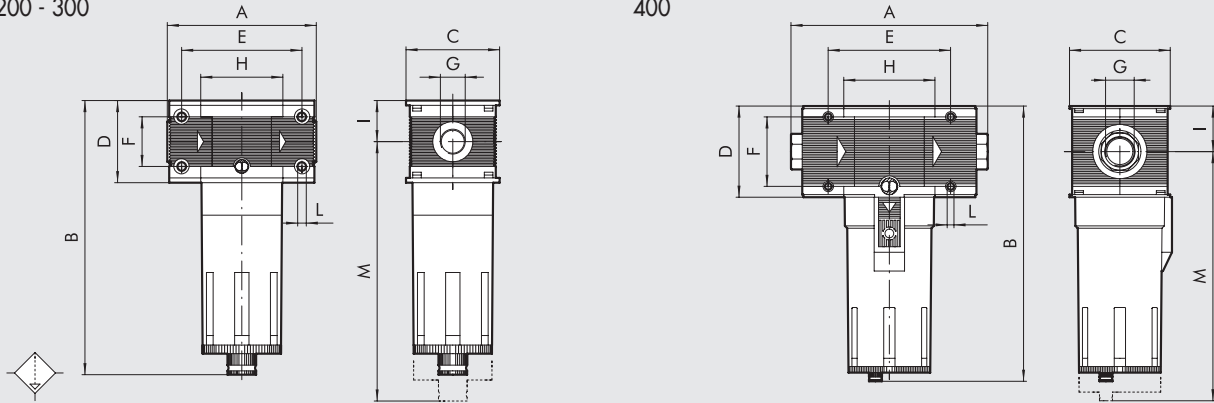

	FIL 100		FIL 200			FIL 300			FIL 400			
	1/4"	3/8"	1/4"	3/8"	1/2"	1/2"	3/4"	1"	1"	1 1/4"	1 1/2"	2"
Threaded port G												
A	78			93.5		110		112		225 to 255		283 to 313
B	RMSA 144			175			195			320		
	RA -			179			199			324		
	SAC 148			179			-			-		
C	50			63			72			118		
D	43			55			65			105		
E	63			78.5			92			141.4		
F	26			36			42			80		
H	43			55.5			65			105.4		
I	21.5			27.5			32.5			52.5		
L	Hole for M4 screws		Hole for M5 screws			Hole for M5 screws			Hole for M6 screws			
M	RMSA 137			196			215			378		
	RA -			200			219			382		
	SAC 141			200			-			-		

NOTES

SYNOPTIC, SIZES AND VERSIONS

FIL ELEMENT	100 SIZE	1/4 THREADED PORT	20 DEGREE OF FILTRATION	RMSA TYPE OF DRAIN
FIL.	100	1/4	5 = 5 µm 20 = 20 µm 50 = 50 µm	RMSA
		3/8		SAC
	200	1/4	50 = 50 µm	RMSA
		3/8		SAC
		1/2		RA*
	300	1/2	50 = 50 µm	RMSA
		3/4		RA
	400	1	50 = 50 µm	
		1 1/4		
		1 1/2		
		2		

RMSA: drain with manual condensate discharge and automatic discharge at zero pressure
 RA: automatic drain with condensate discharge, independent of pressure and flow rate. (for size 300 and 400). Version conveys the draining by inserting the pipe having internal diameter 6 mm in the lower port.
 SAC: automatic drain with condensate discharge.
Operates by pressure drop – requires variable air take-offs.
 (for size 100 and 200)
 * For Skillair® 200 with RA, please contact our sales assistance department.

ORDERING CODES

Code	Description	Code	Description	Code	Description
Skillair® 100 FILTER		Skillair® 300 FILTER		Skillair® 400 FILTER	
3280001A	FIL 100 5 RMSA without end plates	4480001A	FIL 300 5 RMSA without end plates	6180001A	FIL 400 5 RMSA without end plates
3280007A	FIL 100 5 SAC without end plates	4480002A	FIL 300 20 RMSA without end plates	6180002A	FIL 400 20 RMSA without end plates
3280002A	FIL 100 20 RMSA without end plates	4480003A	FIL 300 50 RMSA without end plates	6180003A	FIL 400 50 RMSA without end plates
3280008A	FIL 100 20 SAC without end plates	4480004A	FIL 300 5 RA without end plates	6180004A	FIL 400 5 RA without end plates
3280003A	FIL 100 50 RMSA without end plates	4480005A	FIL 300 20 RA without end plates	6180005A	FIL 400 20 RA without end plates
3280009A	FIL 100 50 SAC without end plates	4480006A	FIL 300 50 RA without end plates	6180006A	FIL 400 50 RA without end plates
3280001	FIL 100 1/4 5 RMSA	4480001	FIL 300 1/2 5 RMSA	6180001	FIL 400 1 5 RMSA
3280007	FIL 100 1/4 5 SAC	4480002	FIL 300 1/2 20 RMSA	6180002	FIL 400 1 20 RMSA
3280002	FIL 100 1/4 20 RMSA	4480003	FIL 300 1/2 50 RMSA	6180003	FIL 400 1 50 RMSA
3280008	FIL 100 1/4 20 SAC	4480004	FIL 300 1/2 5 RA	6180004	FIL 400 1 5 RA
3280003	FIL 100 1/4 50 RMSA	4480005	FIL 300 1/2 20 RA	6180005	FIL 400 1 20 RA
3280009	FIL 100 1/4 50 SAC	4480006	FIL 300 1/2 50 RA	6180006	FIL 400 1 50 RA
3380001	FIL 100 3/8 5 RMSA	4580001	FIL 300 3/4 5 RMSA	6280001	FIL 400 1 1/4 5 RMSA
3380007	FIL 100 3/8 5 SAC	4580002	FIL 300 3/4 20 RMSA	6280002	FIL 400 1 1/4 20 RMSA
3380002	FIL 100 3/8 20 RMSA	4580003	FIL 300 3/4 50 RMSA	6280003	FIL 400 1 1/4 50 RMSA
3380008	FIL 100 3/8 20 SAC	4580004	FIL 300 3/4 5 RA	6280004	FIL 400 1 1/4 5 RA
3380003	FIL 100 3/8 50 RMSA	4580005	FIL 300 3/4 20 RA	6280005	FIL 400 1 1/4 20 RA
3380009	FIL 100 3/8 50 SAC	4580006	FIL 300 3/4 50 RA	6280006	FIL 400 1 1/4 50 RA
Skillair® 200 FILTER		4680001	FIL 300 1 5 RMSA	6380001	FIL 400 1 1/2 5 RMSA
3480001A	FIL 200 5 RMSA without end plates	4680002	FIL 300 1 20 RMSA	6380002	FIL 400 1 1/2 20 RMSA
3480007A	FIL 200 5 SAC without end plates	4680003	FIL 300 1 50 RMSA	6380003	FIL 400 1 1/2 50 RMSA
3480002A	FIL 200 20 RMSA without end plates	4680004	FIL 300 1 5 RA	6380004	FIL 400 1 1/2 5 RA
3480008A	FIL 200 20 SAC without end plates	4680005	FIL 300 1 20 RA	6380005	FIL 400 1 1/2 20 RA
3480003A	FIL 200 50 RMSA without end plates	4680006	FIL 300 1 50 RA	6380006	FIL 400 1 1/2 50 RA
3480009A	FIL 200 50 SAC without end plates			6480001	FIL 400 2 5 RMSA
3480001	FIL 200 1/4 5 RMSA			6480002	FIL 400 2 20 RMSA
3480007	FIL 200 1/4 5 SAC			6480003	FIL 400 2 50 RMSA
3480002	FIL 200 1/4 20 RMSA			6480004	FIL 400 2 5 RA
3480008	FIL 200 1/4 20 SAC			6480005	FIL 400 2 20 RA
3480003	FIL 200 1/4 50 RMSA			6480006	FIL 400 2 50 RA
3480009	FIL 200 1/4 50 SAC				
3580001	FIL 200 3/8 5 RMSA				
3580007	FIL 200 3/8 5 SAC				
3580002	FIL 200 3/8 20 RMSA				
3580008	FIL 200 3/8 20 SAC				
3580003	FIL 200 3/8 50 RMSA				
3580009	FIL 200 3/8 50 SAC				
3680001	FIL 200 1/2 5 RMSA				
3680007	FIL 200 1/2 5 SAC				
3680002	FIL 200 1/2 20 RMSA				
3680008	FIL 200 1/2 20 SAC				
3680003	FIL 200 1/2 50 RMSA				
3680009	FIL 200 1/2 50 SAC				

UNITS

Skillair® FILTER

Skillair® DEPURATOR



The role of the depurator is to separate the liquid and solid particles contained in the compressed air with a high degree of efficiency. This separation is carried out using a special filtering element called a "coalescence cartridge".



TECHNICAL DATA	DEP 100		DEP 200			DEP 300			DEP 400			
	1/4"	3/8"	1/4"	3/8"	1/2"	1/2"	3/4"	1"	1"	1 1/4"	1 1/2"	2"
Threaded port	1/4"	3/8"	1/4"	3/8"	1/2"	1/2"	3/4"	1"	1"	1 1/4"	1 1/2"	2"
Degree of purification	99.97% at 0.01 µm		99.97% at 0.01 µm			99.97% at 0.01 µm			99.97% at 0.01 µm			
Max. inlet pressure	MPa	1.5	1.3			1.3			1.3		1.3	
	bar	15	13			13			13		13	
Suggested flow at 6 bar	psi	217	188			188			188		188	
	Nl/min	230	360			500			2300		2250	
Maximum suggested flow rate	See next page											
Max temperature at: 1 MPa; 10 bar; 145 psi	°C	50	50			50			50		50	
	°F	122	122			122			122		122	
Weight	kg	0.4	0.9			1.4			4.2		5	
Wall fixing screws		M4 x 50	M5 x 60			M5 x 70			M6 x 110		M6 x 110	
Bowl capacity	cm³	22	45			75			270		270	
Mounting position		Vertical	Vertical			Vertical			Vertical		Vertical	
Drain		RMSA	RMSA			RMSA - RA			RMSA - RA		RMSA - RA	
Fluid	5 µm filtered air											
Notes on use	RMSA: drain with manual condensate discharge and automatic discharge at zero pressure RA: automatic drain with condensate discharge, independent of pressure and flow rate. Version conveys the draining by inserting the pipe having internal diameter 6 mm in the lower port. It is advisable to mount a 5 µm pre-filter in order to separate the solid particles first. The maximum inlet pressure for the version with RA automatic condensate drainage must not exceed 10 bar.											

UNITS
Skillair® DEPURATOR

HOW THE COALESCENCE CARTRIDGE WORKS

Air from the mains – full of impurities – flows into the coalescence cartridge and then passes through the crossed micro-fibres that make up the cartridge. During this movement the liquid particles come into contact with the crossed micro-fibres and adhere to them. Due to the air pressure and gravity they join up with other micro-drops at each cross-over point and gradually increase in volume, leading to the physical phenomenon called coalescence. When they stop moving, the drops deposit on the outside of the cartridge, from which they detach and drop to the bottom. Since the volume of liquid leaving the cartridge is exactly the same as the drops arriving, the coalescence cartridge ought to work indefinitely. Solid particles are caught with the same efficiency but, unlike drops, they are not drained out and clog the cartridge. To get round this problem, it is necessary to mount a 5 µm pre-filter before the fine oil filter to separate the solid particles first.

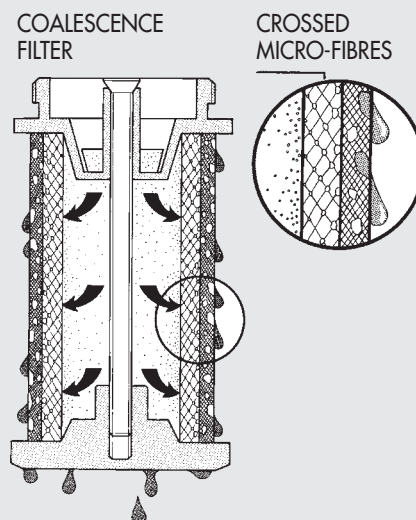

FLOW CHARTS

DEP 100 1/4 - 3/8

$\Delta P = (P_m - P_v)$
psi kPa bar

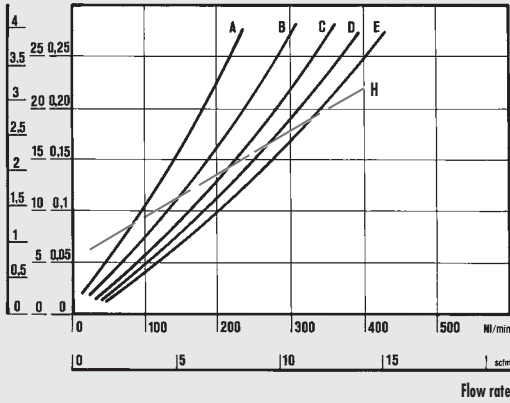

DEP 400 1"

$\Delta P = (P_m - P_v)$
psi kPa bar

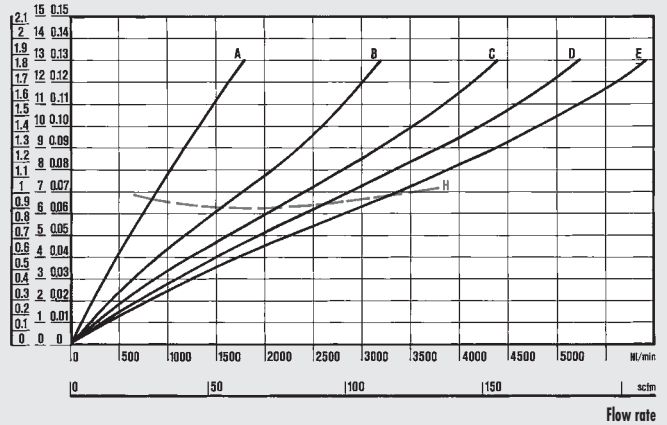

DEP 200 1/4 - 3/8 - 1/2

$\Delta P = (P_m - P_v)$
psi kPa bar

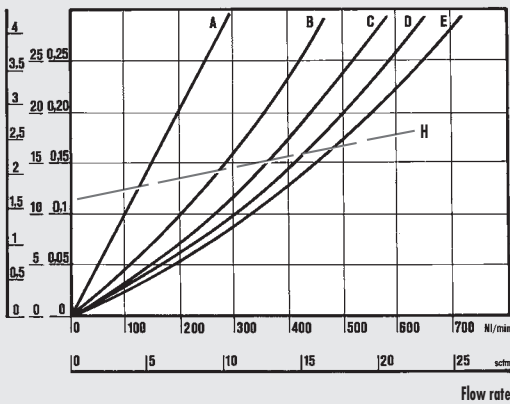

DEP 400 2"

$\Delta P = (P_m - P_v)$
psi kPa bar

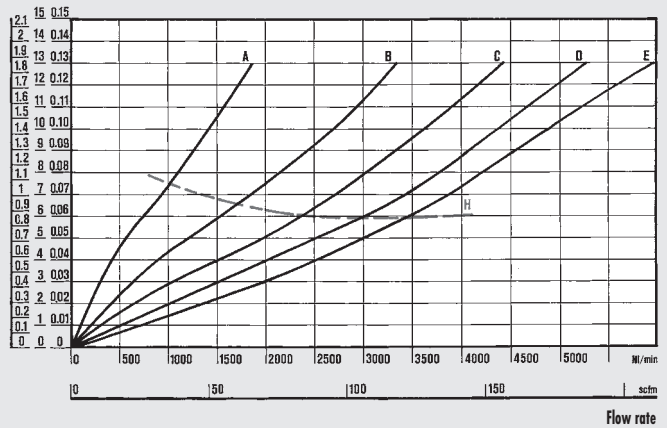

DEP 300 1/2 - 3/4 - 1

$\Delta P = (P_m - P_v)$
psi kPa bar

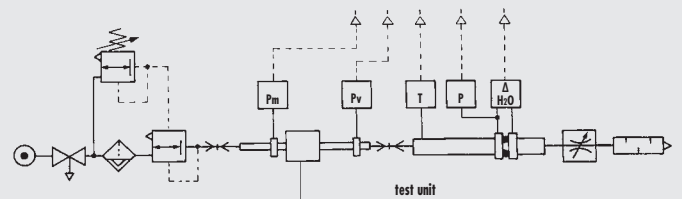
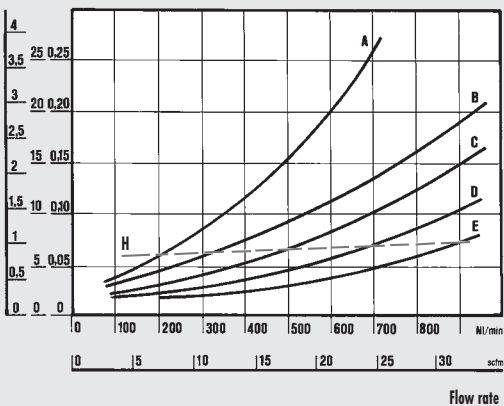

• Flow tests carried out at the Department of Mechanics, Turin Polytechnic, using the computerized test bench following CETOP RP50R recommendations (ISO DIS 6358-2-approved) with ISO 5167 diaphragm gauge.

- (A) = 2 bar - 0.2 MPa - 29 psi
- (B) = 4 bar - 0.4 MPa - 58 psi
- (C) = 6 bar - 0.6 MPa - 87 psi
- (D) = 8 bar - 0.8 MPa - 116 psi
- (E) = 10 bar - 1 MPa - 145 psi
- (H) = maximum flow rate recommended for optimal operation

DIMENSIONS

100 - 200 - 300

400

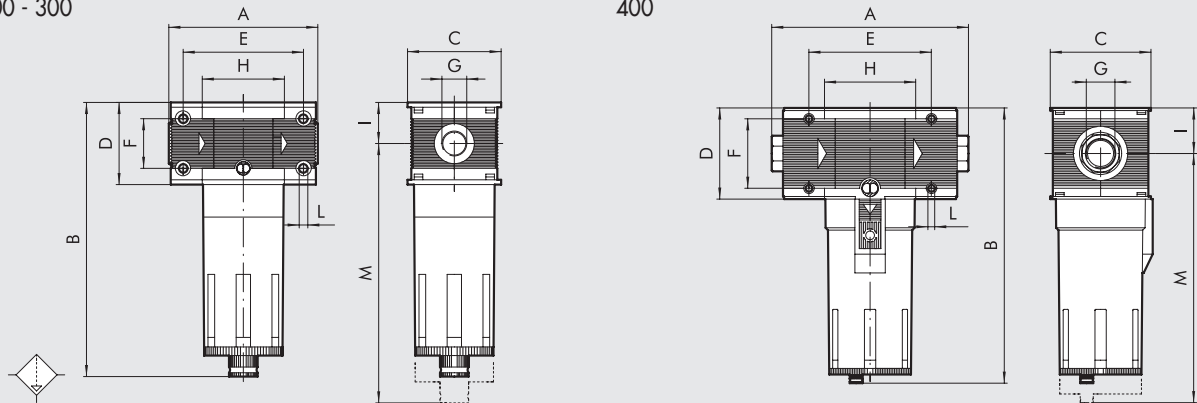

	DEP 100		DEP 200			DEP 300			DEP 400			
Threaded port G	1/4"	3/8"	1/4"	3/8"	1/2"	1/2"	3/4"	1"	1"	1 1/4"	1 1/2"	2"
A	78		93.5			110		112	225 to 255			
B	RMSA	144	175			195		320				
	RA	-	-			199		324				
C	50		63			72		118				
D	43		55			65		105				
E	63		78.5			92		141.4				
F	26		36			42		80				
H	43		55.5			65		105.4				
I	21.5		27.5			32.5		52.5				
L	Hole for M4 screws		Hole for M5 screws			Hole for M5 screws		Hole for M6 screws				
M	RMSA	137	196			215		378				
	RA	-	-			219		382				

SYNOPTIC, SIZES AND VERSIONS

DEP	100	1/4	RMSA
ELEMENT	SIZE	THREADED PORT	TYPE OF DRAIN
DEP	100	1/4	RMSA
	200	3/8	
	300	1/4	
	400	3/8	
		1/2	RMSA
		3/4	RA
		1	
		1	
		1 1/4	
		1 1/2	
		2	

RMSA: drain with manual condensate discharge and automatic discharge at zero pressure
 RA: automatic drain with condensate discharge, independent of pressure and flow rate.
 (for size 300 and 400).
 Version conveys the draining by inserting the pipe having internal diameter 6 mm in the lower port.

ORDERING CODES

Code	Description	Code	Description	Code	Description
Skillair® 100 DEPURATOR		Skillair® 300 DEPURATOR		Skillair® 400 DEPURATOR	
3288001A	D 100 RMSA without end plates	4488001A	D 300 RMSA without end plates	6188001A	D 400 RMSA without end plates
3288001	D 100 1/4 RMSA	4488002A	D 300 RA without end plates	6188002A	D 400 RA without end plates
3388001	D 100 3/8 RMSA	4488001	D 300 1/2 RMSA	6188001	D 400 1 RMSA
		4488002	D 300 1/2 RA	6188002	D 400 1 RA
		4588001	D 300 3/4 RMSA	6288001	D 400 1 1/4 RMSA
		4588002	D 300 3/4 RA	6288002	D 400 1 1/4 RA
		4688001	D 300 1 RMSA	6388001	D 400 1 1/2 RMSA
		4688002	D 300 1 RA	6388002	D 400 1 1/2 RA
				6488001	D 400 2 RMSA
				6488002	D 400 2 RA

Skillair® ACTIVE CARBON FILTER

Active carbon filtering systems are the most efficient in the industry as they eliminate all traces of oils, solvents and hydrocarbons, and remove unpleasant odours from the air.

The operating principle is based on active carbon's ability to absorb the majority of the polluting particles in the air thanks to the presence of tiny passages inside the carbon granules.

The incoming air must be filtered (5 µm) and purified (0.01 µm) to increase the duration and efficiency of the cartridge.

The cartridge must be replaced at set intervals since there is no difference in load loss between an efficient cartridge and a saturated one.

N.B. To maintain the same performance and duration specified on the data sheet, the load loss (ΔP) must not exceed 75 mbar.



UNITS

Skillair® ACTIVE CARBON FILTER

TECHNICAL DATA	AC 100		AC 200			AC 300			AC 400				
	1/4"	3/8"	1/4"	3/8"	1/2"	1/2"	3/4"	1"	1"	1 1/4"	1 1/2"	2"	
Threaded port													
Residual oil at 20°C *	mg/m ³		0.003			0.003			0.003			0.003	
Duration of cartridge *	hours		4000			4000			4000			1000	
Max. inlet pressure	MPa		1.5			1.3			1.3			1.3	
	bar		15			13			13			13	
	psi		217			188			188			188	
Max temperature at: 1 MPa; 10 bar; 145 psi	°C		50			50			50			50	
	°F		122			122			122			122	
Weight	kg		0.4			0.9			1.4			4.2 5	
Wall fixing screws	M4 x 50		M5 x 60			M5 x 70			M6 x 110				
Mounting position	In any position.												
Fluid	0.01 µm filtered and dehydrated air.												
Notes on use	Upstream it's necessary to mount a coalescence filter dehydrator of 0.01 µm.												
* if the load loss of 75 mbar is not exceeded													

FLOW CHARTS

AC 100 1/4 - 3/8

ΔP = (Pm-Pv)

psi kPa bar

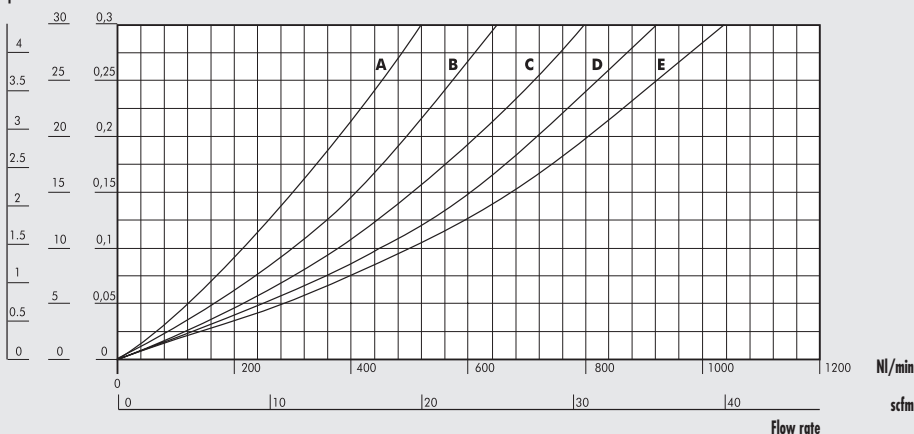

- (A) = 2 bar - 0.2 MPa - 29 psi
- (B) = 4 bar - 0.4 MPa - 58 psi
- (C) = 6 bar - 0.6 MPa - 87 psi
- (D) = 8 bar - 0.8 MPa - 116 psi
- (E) = 10 bar - 1 MPa - 145 psi

FLOW CHARTS

AC 200 1/4 - 3/8 - 1/2

$\Delta P = (P_m - P_v)$

psi kPa bar

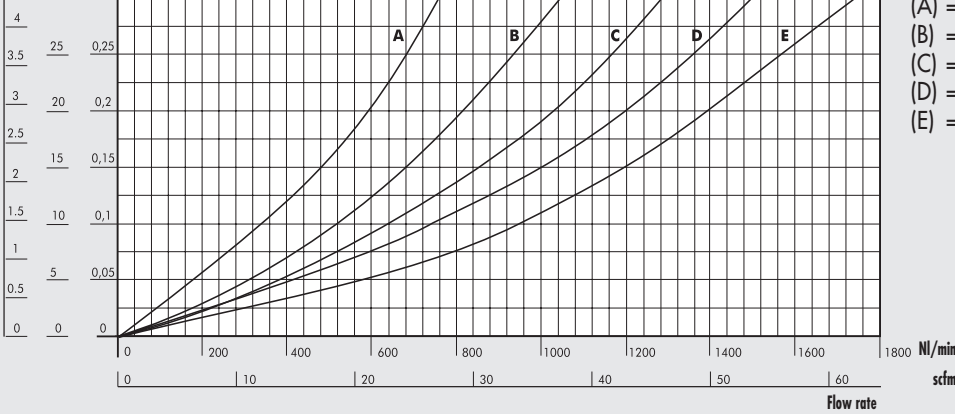

- (A) = 2 bar - 0.2 MPa - 29 psi
- (B) = 4 bar - 0.4 MPa - 58 psi
- (C) = 6 bar - 0.6 MPa - 87 psi
- (D) = 8 bar - 0.8 MPa - 116 psi
- (E) = 10 bar - 1 MPa - 145 psi

AC 300 1/2 - 3/4 - 1

$\Delta P = (P_m - P_v)$

psi kPa bar

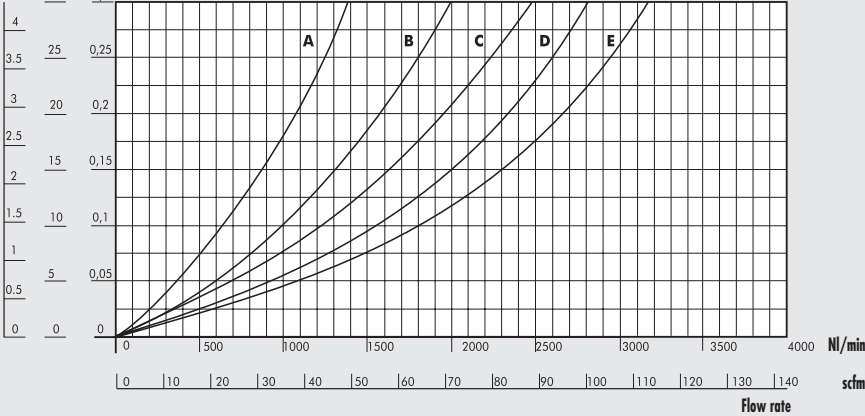

- (A) = 2 bar - 0.2 MPa - 29 psi
- (B) = 4 bar - 0.4 MPa - 58 psi
- (C) = 6 bar - 0.6 MPa - 87 psi
- (D) = 8 bar - 0.8 MPa - 116 psi
- (E) = 10 bar - 1 MPa - 145 psi

AC 400 1

$\Delta P = (P_m - P_v)$

psi kPa bar

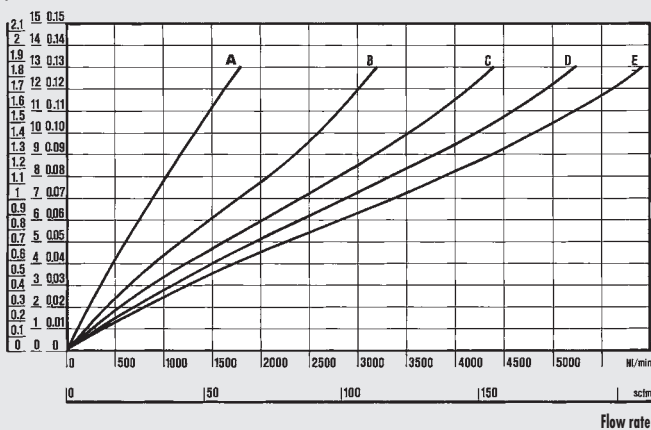

- (A) = 2 bar - 0.2 MPa - 29 psi
- (B) = 4 bar - 0.4 MPa - 58 psi
- (C) = 6 bar - 0.6 MPa - 87 psi
- (D) = 8 bar - 0.8 MPa - 116 psi
- (E) = 10 bar - 1 MPa - 145 psi

AC 400 2

$\Delta P = (P_m - P_v)$

psi kPa bar

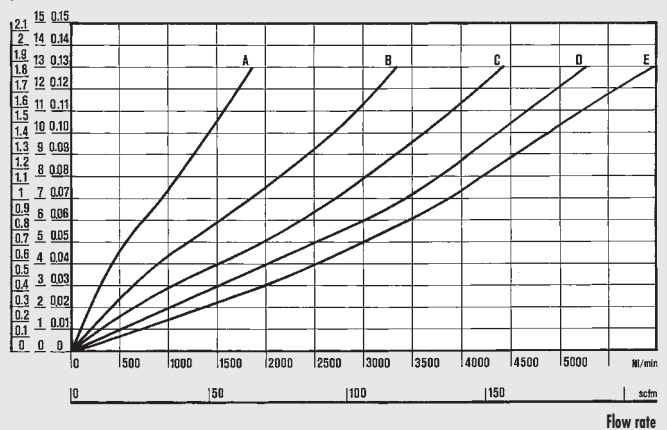

- (A) = 2 bar - 0.2 MPa - 29 psi
- (B) = 4 bar - 0.4 MPa - 58 psi
- (C) = 6 bar - 0.6 MPa - 87 psi
- (D) = 8 bar - 0.8 MPa - 116 psi
- (E) = 10 bar - 1 MPa - 145 psi

DIMENSIONS

100 - 200 - 300

400

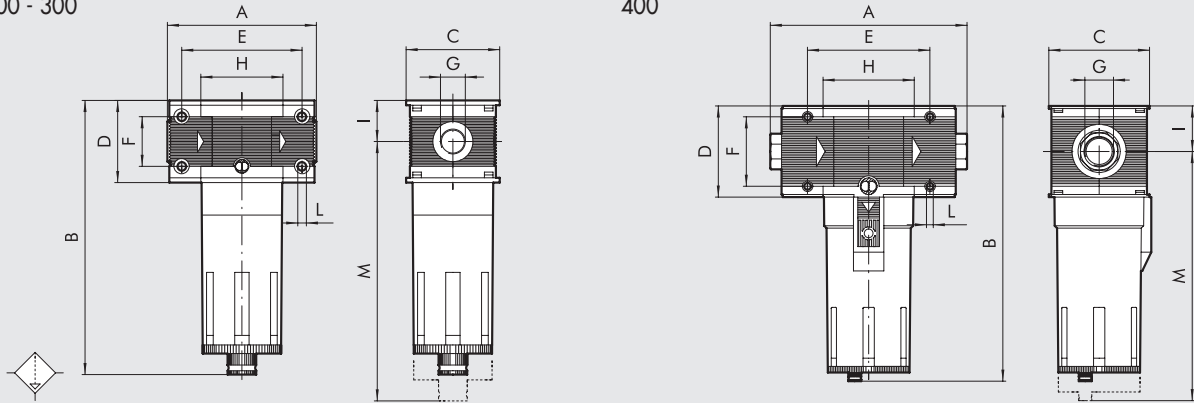

	AC 100		AC 200			AC 300			AC 400			
Threaded port G	1/4"	3/8"	1/4"	3/8"	1/2"	1/2"	3/4"	1"	1"	1 1/4"	1 1/2"	2"
A	78		93.5			110		112	225 to 255			
B	144		175			195			320			
C	50		63			72			118			
D	43		55			65			105			
E	63		78.5			92			141.4			
F	26		36			42			80			
H	43		55.5			65			105.4			
I	21.5		27.5			32.5			52.5			
L	Hole for M4 screws		Hole for M5 screws			Hole for M5 screws			Hole for M6 screws			
M	137		196			215			378			

SYNOPTIC, SIZES AND VERSIONS

AC ELEMENT	100 SIZE	1/4 THREADED PORT	RMSA TYPE	RMSA: drain with manual condensate discharge and automatic discharge at zero pressure.
AC = Active carbon	100	1/4	RMSA	
	200	3/8		
	300	1/4		
	400	3/8		
		1/2		
		1		
		1		
		1 1/4		
		1 1/2		
		2		

ORDERING CODES

Code	Description	Code	Description	Code	Description
Skillair® 100 ACTIVE CARBON FILTER		Skillair® 300 ACTIVE CARBON FILTER		Skillair® 400 ACTIVE CARBON FILTER	
3288003A	FIL AC 100 RMSA without end plates	4488003A	FIL AC 300 RMSA without end plates	6188003A	FIL AC 400 RMSA without end plates
3288003	FIL AC 100 1/4 RMSA	4488003	FIL AC 300 1/2 RMSA	6188003	FIL AC 400 1 RMSA
3388003	FIL AC 100 3/8 RMSA	4588003	FIL AC 300 3/4 RMSA	6288003	FIL AC 400 1 1/4 RMSA
		4688003	FIL AC 300 1 RMSA	6388003	FIL AC 400 1 1/2 RMSA
Skillair® 200 ACTIVE CARBON FILTER				6488003	FIL AC 400 2 RMSA
3488003A	FIL AC 200 RMSA without end plates				
3488003	FIL AC 200 1/4 RMSA				
3588003	FIL AC 200 3/8 RMSA				
3688003	FIL AC 200 1/2 RMSA				

UNITS

Skillair® ACTIVE CARBON FILTER

DIAPHRAGM DRIER SERIES DRY 100 Skillair®



Skillair® diaphragm driers are used to reduce the air's moisture content by lowering the dew point, i.e. the temperature at which condensate starts to form. They use diaphragms with a new cross-fibre system that guarantees a lower consumption of regenerated air and hence power. This is an all-in-one unit complete with a filter, purifier, air intake and drier. The air intake uses air that has been filtered and purified, but not dried, and sends it to utilities not requiring dry air. This is a much more efficient system as only the required quantity of compressed air is dried. An alternative proposal is the drier by itself. As the Skillair® system is modular, it can be inserted in any type of assembly. It is important, however, to remember that only properly filtered and purified air must be supplied to the drier. It's advisable that the drier should be used at the highest pressure as possible.



TECHNICAL DATA	DRY 100	FIL + DEP + PA + DRY 100
Threaded port	1/4" - 3/8"	
Max. inlet pressure	1.3 MPa / 13 bar / 188 psi	
Suggested flow rate at 6.3 bar (0.63 MPa, 91 psi)	Nl/min scfm	230 8
Consumption of compressed air for regeneration at 6.3 bar	Nl/min scfm	20 0.7
Minimum temperature	2°C / 35°F	
Maximum temperature at 1MPa; 10 bar; 145 psi	50°C / 122°F	
Noise level	dB(A)	< 45
Weight	kg	0.84 1.24
Wall fixing screws	M4 x 50	
Mounting position	In any position	Vertical
Drain	-	RMSA: drain with manual condensate discharge and automatic discharge at zero pressure SAC: automatic drain with condensate discharge. Operates by pressure drop - requires variable air take-offs.
Filter bowl and purification bowl capacity	cm³	22
Fluid	Compressed air without condensate max solid particle size: 1 µm max oil residue: 0.01mg/m³	Compressed air
Important note	The drier must always be preceded by a 5 µm filter and a purifier	

COMPONENTS

- ① Body: painted anodized aluminium
- ② Diaphragm: poliester sulfone resin
- ③ Inner tube: salt-water resistant aluminium
- ④ O-Ring seals: NBR
- ⑤ Adapter: anodized aluminium
- ⑥ Flanges: brass
- ⑦ Skillair® body: technopolymer

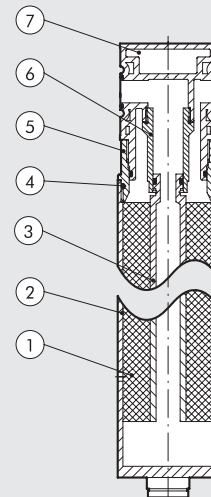

OPERATING PRINCIPLE

The drying element is comprised of cross-fibre diaphragms arranged around an inner tube. The compressed air passes through the tube (A) and flows back through the hollow diaphragms (B). At the same time, the regeneration air required for drying is tapped from the outlet port, expands as it passes through a nozzle (C), which reduces the relative humidity, and flows back along the outer side of the fibres. This allows moist compressed air to flow through the diaphragms and the dry regeneration air outside.

The difference in moisture content causes the water to pass from the compressed air to the regeneration air, which is drained through holes (D) at the bottom of the drier.

ADVANTAGES

- Drying is guaranteed as all the moisture is removed
- Minimum consumption of regeneration air
- Reduce drier maintenance as none of the components are subject to wear
- Environmentally friendly drying process.

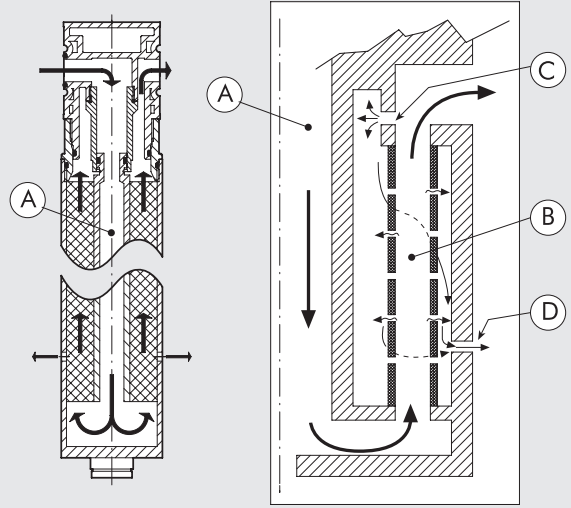

FLOW CHARTS

DRY 100

$\Delta P = (P_m - P_v)$

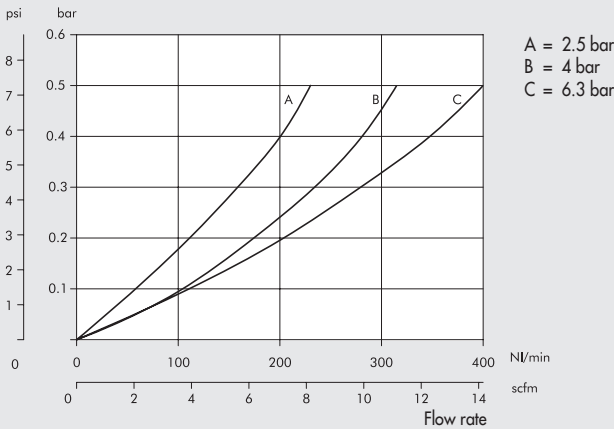

FIL (5 µm) + DEP + PA + DRY 100

$\Delta P = (P_m - P_v)$

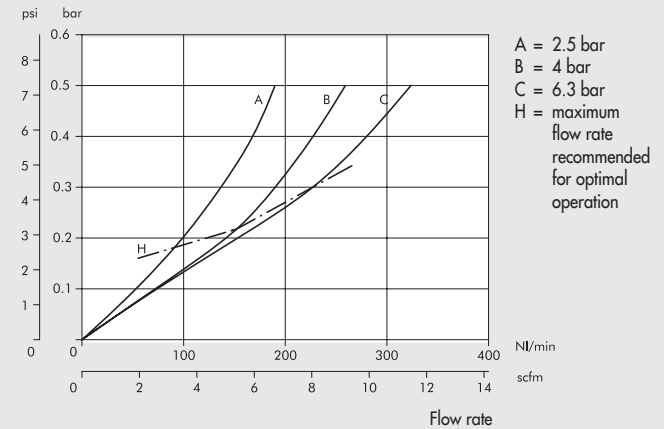

REGENERATION AIR

Thanks to the cross-fiber system, the flow rate loss is much lesser than in traditional linear-fibre systems. In the diagram on the right is indicated the drop-in air flow according to the operating pressure.

N.B.: for the best drying efficiency the highest pressure possible is required, though this implies an increase of the regeneration air.

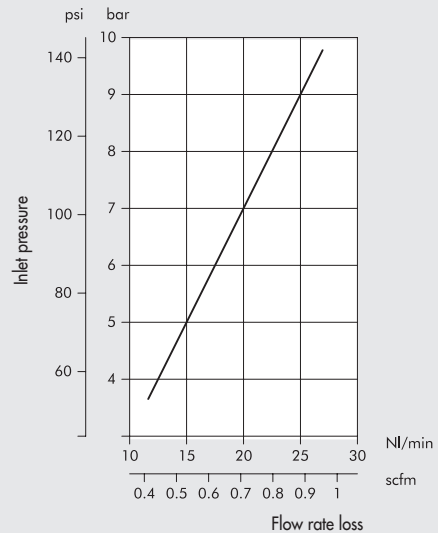

DRYING

Dew point of the outgoing air in nominal reference conditions:

- Dew point referred to atmospheric pressure
- Incoming air with dew point at 25°C (i.e. saturated at 25°C)

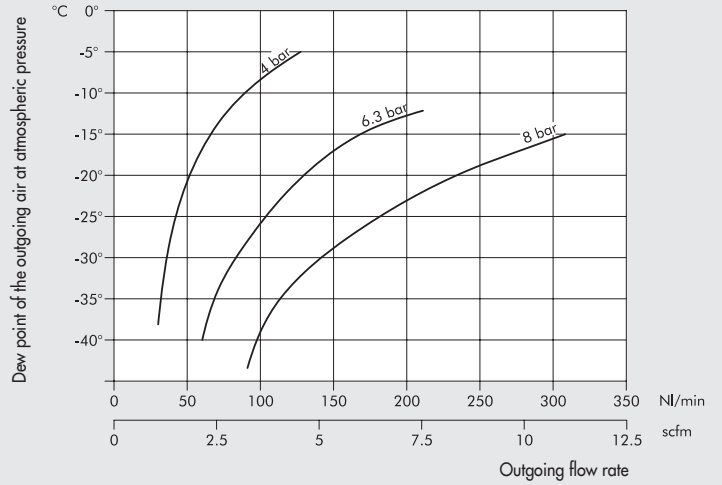

In the diagram below is indicated the dew point of the outgoing compressed air for various input air dew points, depending on the rate of flow of compressed air.

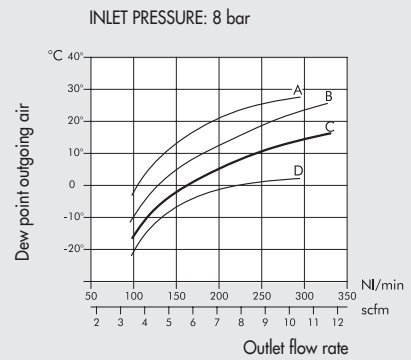
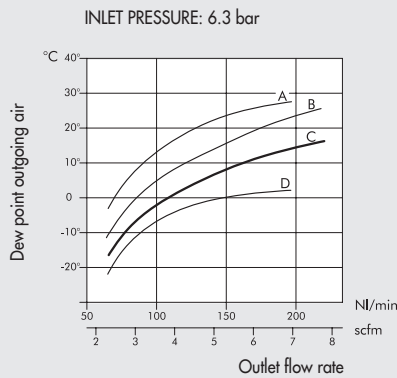
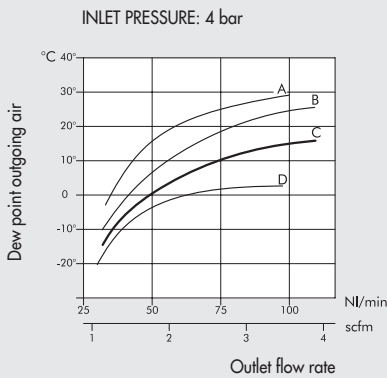

- A: Incoming air with dew point at 45°C
- B: Incoming air with dew point at 35°C

- C: Incoming air with dew point at 25°C
- D: Incoming air with dew point at 15°C

DRY 100 DIMENSIONS

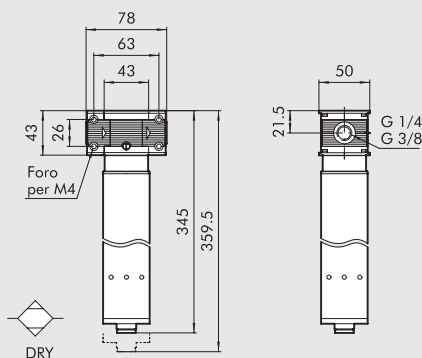

FIL + DEP + PA + DRY 100 DIMENSIONS

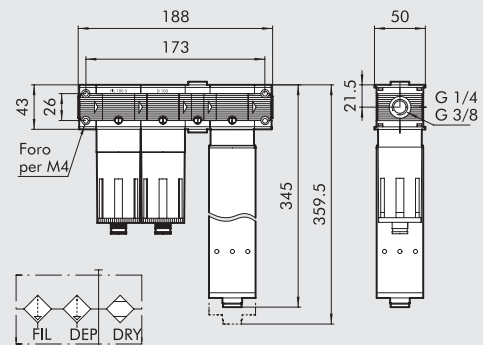

Code	Description
3290001A	DRY 100 without end plates
3290001	DRY 100 1/4"
3390001	DRY 100 3/8"

Code	Description
3291001	F+D+PA+DRY 100 1/4" RMSA-RMSA
3291005	F+D+PA+DRY 100 1/4" SAC-RMSA
3291006	F+D+PA+DRY 100 1/4" SAC-SAC
3391001	F+D+PA+DRY 100 3/8" RMSA-RMSA
3391005	F+D+PA+DRY 100 3/8" SAC-RMSA
3391006	F+D+PA+DRY 100 3/8" SAC-SAC

Skillair® REGULATOR

Each system served by the air supply mains (e.g. actuators and general appliances) requires its own constant operating pressure. It is necessary to use a regulator to regulate the pressure within a set range by means of regulating springs, with the pressure never exceeding the mains pressure.

The new Skillair® regulator uses a rolling diaphragm which gives a much better performance than the flat version.

Advantages of this system:

- Increased stroke, increased valve opening and hence higher flow rate.
- Decreased dynamic and inrush friction; prompt, more sensitive operation.
- Reduced working stress and hence longer life allowing the use of thinner diaphragms (0.45 mm versus 1.5 mm for a flat one) which increases regulator sensitivity and prompt action.
- Increased accuracy in maintaining the set pressure with both variable flow rates and different feed pressures.
- Downstream overpressures relieved quickly.



TECHNICAL DATA	REG 100		REG 200			REG 300			REG 400 PILOT OPERATED*			
	1/4"	3/8"	1/4"	3/8"	1/2"	1/2"	3/4"	1"	1"	1 1/4"	1 1/2"	2"
Threaded port												
Setting range	bar		0 to 2 - 0 to 4 - 0 to 8 - 0 to 12						Depending on the pilot operated regulator			
Max. input pressure	MPa		1.5		1.5		1.3		1.3		1.3	
	bar		15		15		13		13		13	
	psi		217		217		188		188		188	
Flow rate at 6.3 bar (0.63 MPa to 91 psi)	NL/min		1100		2500		3500		18000		20000	
ΔP 0.5 bar (0.05 MPa to 7 psi)	scfm		39		88		124		363		707	
Flow rate at 6.3 bar (0.63 MPa to 91 psi)	NL/min		1600		3500		7000		-		-	
ΔP 1 bar (0.1 MPa to 14 psi)	scfm		57		124		247		-		-	
Max temperature at 1 MPa; 10 bar; 145 psi	°C		50		50		50		50		50	
	°F		122		122		122		122		122	
Weight	kg		0.4		0.7		1.4		4.8		5.6	
Wall fixing screws	M4 x 50		M5 x 60		M5 x 70		M6 x 110		M6 x 110		M6 x 110	
Pressure gauge port	1/8"		1/8"		1/8"		1/8"		1/4"		1/4"	
Mounting position	In any position											
Fluid	Filtered lubricated or unlubricated compressed air. Lubrication, if used, must be continuous.											
Notes on use	The regulator pressure must always be set upwards. For increased sensitivity, use a pressure regulator with a rated pressure as close as possible to the required value.											
	Do not take air from pressure gauge ports.											
	*Supplied without a pilot regulator.											

COMPONENTS REG 100 - 200 - 300

- ① Technopolymer body
- ② Zamak end plate
- ③ Technopolymer knob
- ④ Technopolymer bell
- ⑤ OT58 brass adjusting screw
- ⑥ OT58 brass scroll
- ⑦ Steel adjusting spring
- ⑧ Technopolymer ring nut
- ⑨ Rolling diaphragm
- ⑩ NBR relieving gaskets
- ⑪ OT58 brass stem
- ⑫ Valve with NBR vulcanized gasket
- ⑬ Stainless steel valve spring
- ⑭ Technopolymer plug
- ⑮ NBR gaskets

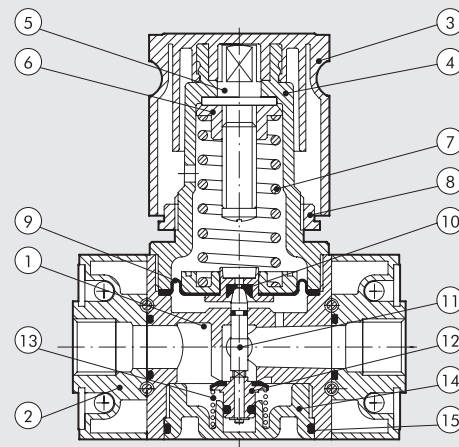

COMPONENTS REG 400 PILOT OPERATED

- ① Aluminium body
- ② Aluminium end plate
- ③ Anodized aluminium threaded bush, axial adjustment
- ④ OT58 brass retaining ring
- ⑤ Rolling diaphragm
- ⑥ Anodized aluminium plug
- ⑦ Stainless steel valve spring
- ⑧ OT58 brass stem with air relief hole
- ⑨ Valve with NBR vulcanized gasket
- ⑩ NBR gaskets

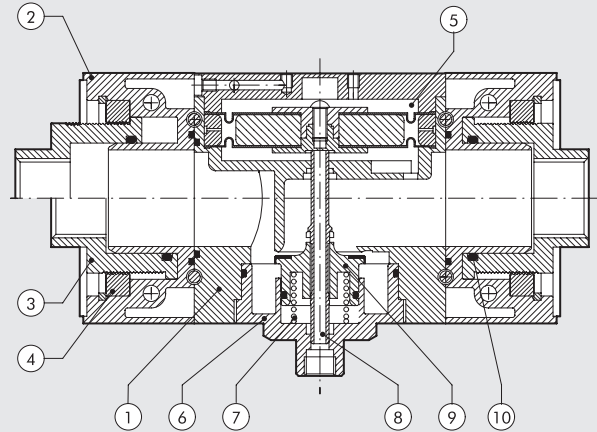

FLOW CHARTS

REG 100 1/4 - 3/8

Preset pressure
Pm = 7 bar - 0.7 MPa - 100 psi

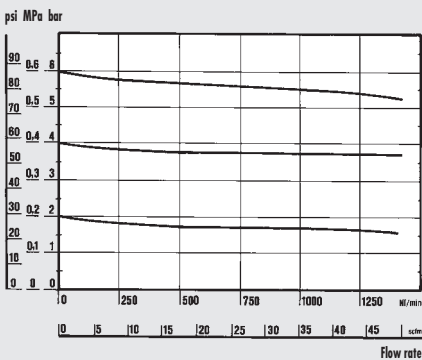

REG 200 1/4 - 3/8 - 1/2

Preset pressure
Pm = 7 bar - 0.7 MPa - 100 psi

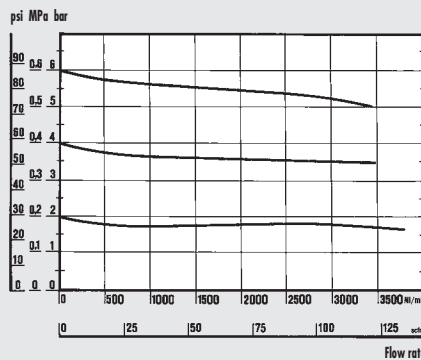

REG 300 1/2 - 3/4 - 1

Preset pressure
Pm = 7 bar - 0.7 MPa - 100 psi

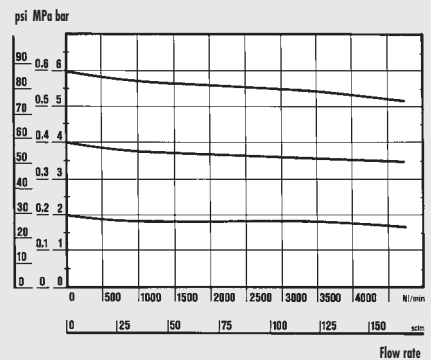

REG 400 1"

Preset pressure
Pm = 7 bar - 0.7 MPa - 100 psi

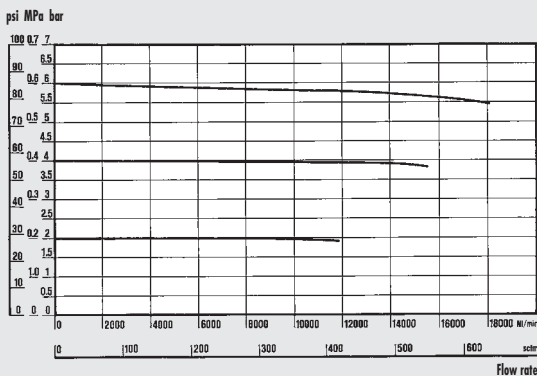

REG 400 2"

Preset pressure
Pm = 7 bar - 0.7 MPa - 100 psi

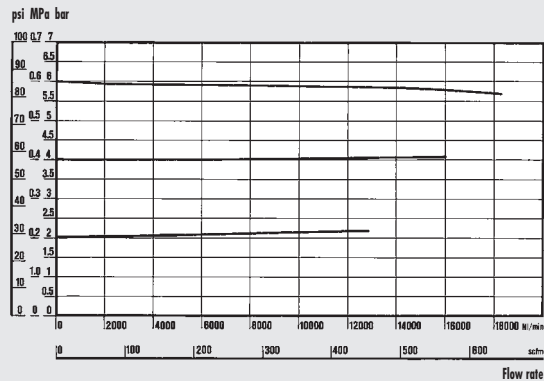

• Flow tests carried out at the Department of Mechanics, Turin Polytechnic, using the computerized test bench following CETOP RP50R recommendations (ISO DIS 6358-2-approved) with ISO 5167 diaphragm gauge.

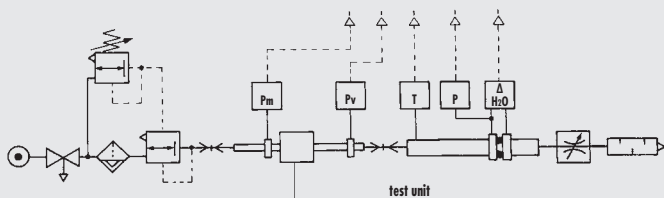

DIMENSIONS

100 - 200 - 300

400

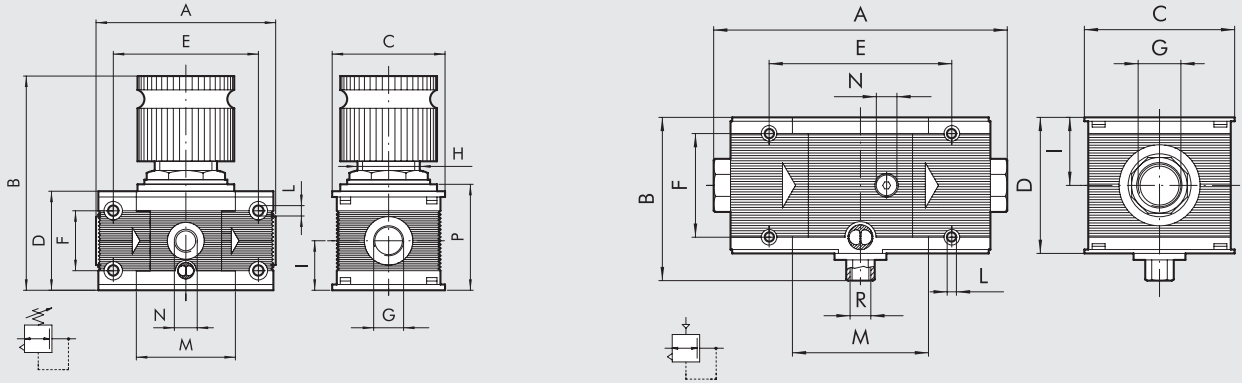

	REG 100		REG 200			REG 300			REG 400			
Threaded port G	1/4"	3/8"	1/4"	3/8"	1/2"	1/2"	3/4"	1"	1"	1 1/4"	1 1/2"	2"
A	78		93.5			110		112	225 to 255			283 to 313
B	98		125				148		127			
C	50		63				72		118			
D	43		55				65		105			
E	63		78.5				92		141.4			
F	26		36				42		80			
H	30 x 1.5		40 x 1.5			48 x 1.5			-			
I	21.5		27.5			32.5			52.5			
L	Hole for M4 screws		Hole for M5 screws			Hole for M5 screws			Hole for M6 screws			
M	43		55.5			65			105.4			
N (pressure gauge port)	1/8"		1/8"			1/8"			1/4"			
P	46		58			69			-			
R (relief)	-		-			-			1/4"			

INSTRUCTIONS FOR USE REG 400

①

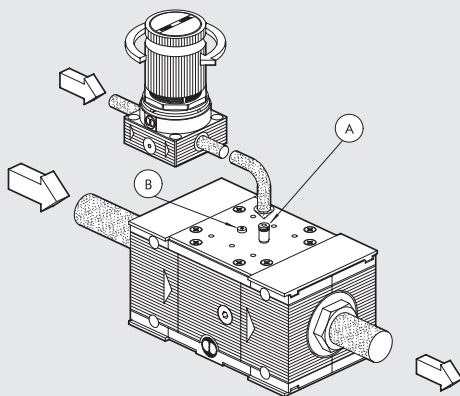

REMOTE PILOT

- Fit the A7 M5 plug into the threaded hole ② (close to the entrance).
- Fit the M5 fitting into the threaded hole ① as close to the entrance as possible.
- Connect the downstream circuit of the selected pilot operated regulator to the input ① (R1 fitting).
- Set the required pressure on the pilot operated regulator.

②

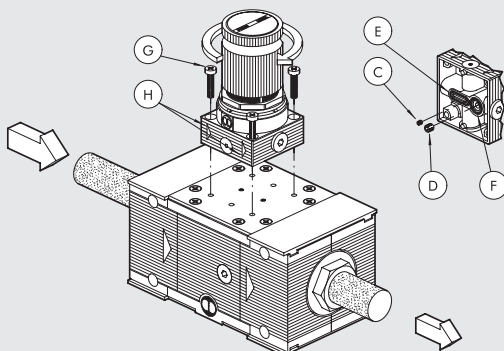

DIRECT PILOT WITH Skillair® PILOT OPERATED REGULATOR

- Remove the pins ③ and ④ under the pilot operated regulator.
- Check that the two gaskets ⑤ and ⑥ under the pilot are in place.
- Fix the pilot operated regulator to the base of the regulator using the self-threading screws ②. Make sure the arrows ⑦ point in the same direction as the arrows in relief under the base of the regulator.

INSTRUCTIONS FOR USE REG 400

③

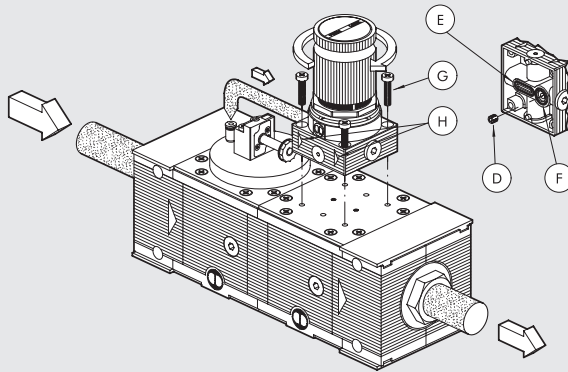

PILOT REGULATOR FOLLOW-UP LINK

This is used when the regulator is mounted downstream of a V3V valve or an APR. The air can be bled from the V3V or APR valves instead of from the regulator relieving system.

- Remove only the stud pin marked with a letter ③ under the pilot regulator.
- Check the two gaskets under the pilot marked ⑤ and ⑥.
- Secure the pilot regulator to the regulator base with the self-tapping screws marked with a letter ④. Making sure the arrows marked ⑧ point in the same direction as the arrows in relief under the regulator base.
- Remove the A7 M5 plug from the V3V or APR plate and remount the fitting.
- Connect the pilot regulator supply to the fitting.

SYNOPTIC, SIZES AND VERSIONS

REG ELEMENT	100 SIZE	1/4 THREADED PORT	02 SETTING RANGE
REG	100	1/4	02 = 0 to 2 bar
	200	3/8	04 = 0 to 4 bar
		1/4	08 = 0 to 8 bar
		3/8	012 = 0 to 12 bar
	300	1/2	
		1/2	
		3/4	
		1	
	400	1	Depending on the pilot used
		1 1/4	
		1 1/2	
		2	

The pilot operated regulator is necessary for size 400. See page C3.27

ORDERING CODES

Code	Description	Code	Description	Code	Description
Skillair® 100 REGULATOR		Skillair® 200 REGULATOR		Skillair® 300 REGULATOR	
3202001A	REG 100 02 without end plates	3402001A	REG 200 02 without end plates	4402000A	REG 300 02 without end plates
3202002A	REG 100 04 without end plates	3402002A	REG 200 04 without end plates	4402001A	REG 300 04 without end plates
3202003A	REG 100 08 without end plates	3402003A	REG 200 08 without end plates	4402002A	REG 300 08 without end plates
3202004A	REG 100 012 without end plates	3402004A	REG 200 012 without end plates	4402003A	REG 300 012 without end plates
3202001	REG 100 1/4 02	3402001	REG 200 1/4 02	4402000	REG 300 1/2 02
3202002	REG 100 1/4 04	3402002	REG 200 1/4 04	4402001	REG 300 1/2 04
3202003	REG 100 1/4 08	3402003	REG 200 1/4 08	4402002	REG 300 1/2 08
3202004	REG 100 1/4 012	3402004	REG 200 1/4 012	4402003	REG 300 1/2 012
3302001	REG 100 3/8 02	3502001	REG 200 3/8 02	4502000	REG 300 3/4 02
3302002	REG 100 3/8 04	3502002	REG 200 3/8 04	4502001	REG 300 3/4 04
3302003	REG 100 3/8 08	3502003	REG 200 3/8 08	4502002	REG 300 3/4 08
3302004	REG 100 3/8 012	3502004	REG 200 3/8 012	4502003	REG 300 3/4 012
		3602001	REG 200 1/2 02	4602000	REG 300 1 02
		3602002	REG 200 1/2 04	4602001	REG 300 1 04
		3602003	REG 200 1/2 08	4602002	REG 300 1 08
		3602004	REG 200 1/2 012	4602003	REG 300 1 012
				Skillair® 400 REGULATOR	
				6102001A	REG 400 without end plates
				6102001	REG 400 1
				6202001	REG 400 1 1/4
				6302001	REG 400 1 1/2
				6402001	REG 400 2

Skillair® 100 IN-SERIES REGULATOR

TECHNICAL DATA

Threaded inlet port	1/4" - 3/8"
Threaded user port	G 1/8"
Degree of purification	bar 0 to 2 - 0 to 4 - 0 to 8 - 0 to 12
Max. input pressure	1.5 MPa - 15 bar - 217 psi
Flow rate at 6.3 bar (0.63 MPa to 91 psi)	500 NI/min
ΔP 0.5 bar (0.05 MPa to 7 psi)	18 scfm
Flow rate at 6.3 bar (0.63 MPa to 91 psi)	950 NI/min
ΔP 1 bar (0.1 MPa to 14 psi)	34 scfm
Fluid	Filtered, lubricated or unlubricated compressed air. Lubrication, if used, must be continuous
Max temperature	°C 50
at 1 MPa; 10 bar; 145 psi	°F 122
Weight	kg 0.4
Wall fixing screws	M4x50
Mounting position	In any position
Pressure gauge port	G 1/8"
Notes on use	The regulator pressure must always be set upwards. For increased sensitivity, use a pressure regulator with a rated pressure as close as possible to the required value.



DIMENSIONS

	REG 100	REG 100
Threaded port	1/4"	3/8"
A		78
B		98
C		50
D		43
E		63
F		26
G	1/4"	3/8"
H		30 x 1.5
I		21.5
L		Hole for M4 screws
M		43
N (use)		1/8"
P		46

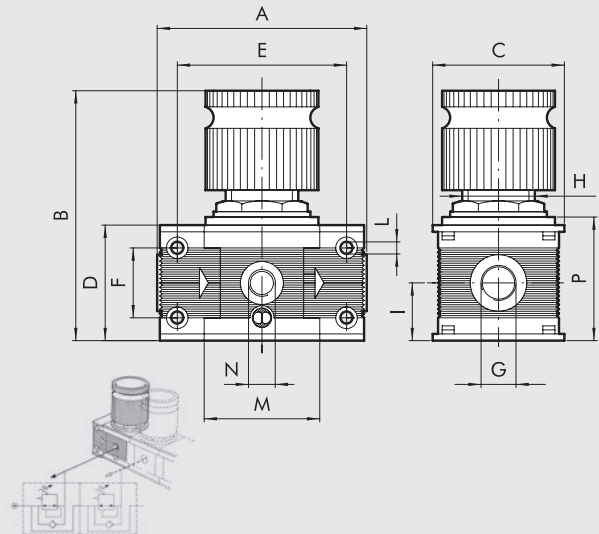

ORDERING CODES

Code	Description
100 IN-SERIES REGULATOR	
3202101A	100 IN-SERIES REG. 0-2 without end plates
3202102A	100 IN-SERIES REG. 0-4 without end plates
3202103A	100 IN-SERIES REG. 0-8 without end plates
3202104A	100 IN-SERIES REG. 0-12 without end plates
3202101	100 IN-SERIES REG. 1/4 0-2
3202102	100 IN-SERIES REG. 1/4 0-4
3202103	100 IN-SERIES REG. 1/4 0-8
3202104	100 IN-SERIES REG. 1/4 0-12
3302101	100 IN-SERIES REG. 3/8 0-2
3302102	100 IN-SERIES REG. 3/8 0-4
3302103	100 IN-SERIES REG. 3/8 0-8
3302104	100 IN-SERIES REG. 3/8 0-12

Several of these Skillair® regulators can be mounted in series, all fed by the same pressure. They can give different set pressures, each independent of the previous regulator.

Operating compressed air can be taken from the pressure gauge ports (G 1/8").

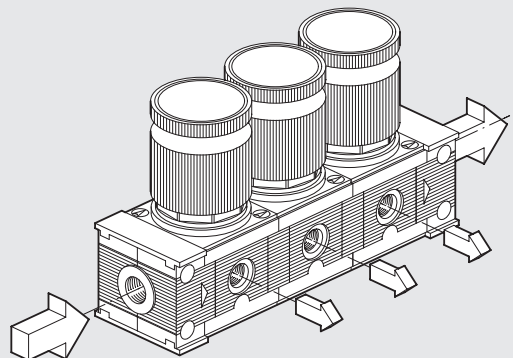

Skillair® PADLOCKABLE REGULATOR



The padlockable regulator has a pin with a hole in it that projects from the top of the knob. When the knob is in the push-lock position, the padlock can be inserted in the hole, preventing the knob from being operated. A padlock and two keys are supplied with the regulator.

The new Skillair® regulator uses a rolling diaphragm which gives a much better performance than the flat version.

Advantages of this system:

- Increased stroke, increased valve opening and hence higher flow rate.
- Decreased dynamic and inrush friction; prompt, more sensitive operation.
- Reduced working stress and hence longer life allowing the use of thinner diaphragms (0.45 mm versus 1.5 mm for a flat one) which increases regulator sensitivity and prompt action.
- Increased accuracy in maintaining the set pressure with both variable flow rates and different feed pressures.
- Downstream overpressures relieved quickly.

Refer to the regulator for technical data and flow curves.



COMPONENTS

- ① Technopolymer body
- ② Zamak end plate
- ③ Technopolymer knob
- ④ Technopolymer bell
- ⑤ Nickel-plated OT58 brass adjusting screw
- ⑥ OT58 brass scroll
- ⑦ Steel adjusting spring
- ⑧ Technopolymer ring nut
- ⑨ Rolling diaphragm
- ⑩ NBR relieving gaskets
- ⑪ OT58 brass stem
- ⑫ Valve with NBR vulcanized gasket
- ⑬ Stainless steel valve spring
- ⑭ Technopolymer plug
- ⑮ NBR gaskets
- ⑯ Padlock

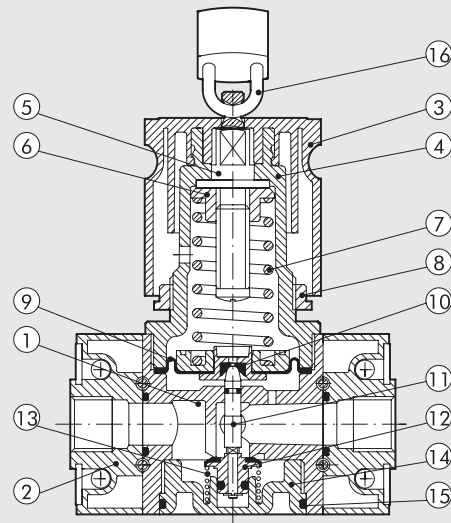

DIMENSIONS

	REG 100 KEY		REG 200 KEY			REG 300 KEY		
Threaded port G	1/4"	3/8"	1/4"	3/8"	1/2"	1/2"	3/4"	1"
A	78		93.5			110		
B	95 to 98		123 to 125			145 to 148		
C	50		63			72		
D	43		55			65		
E	63		78.5			92		
F	26		36			42		
H	30 x 1.5		40 x 1.5			48 x 1.5		
I	21.5		27.5			32.5		
L	Hole for M4 screws		Hole for M5 screws			Hole for M5 screws		
M	43		55.5			65		
N	101		127			151		
O (pressure gauge port)	1/8"		1/8"			1/8"		
P	46		58			69		

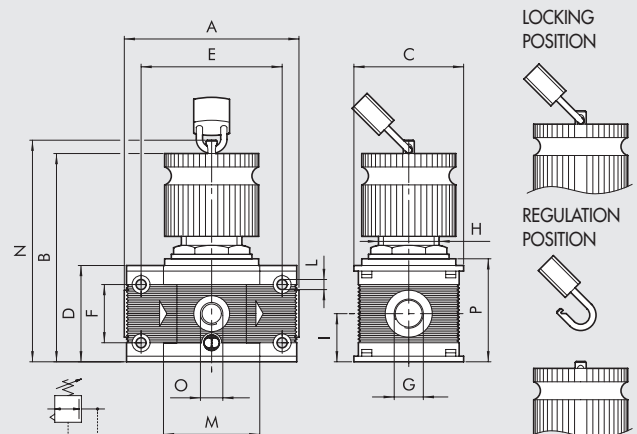

SYNOPTIC, SIZES AND VERSIONS

REG ELEMENT	100 SIZE	KEY TYPE	1/4 THREADED PORT	02 SETTING RANGE
REG = Regulator	100	KEY = Padlockable	1/4	02 = 0 to 2 bar
	200		3/8	04 = 0 to 4 bar
	300		1/4	08 = 0 to 8 bar
			3/8	012 = 0 to 12 bar
			1/2	
			1/2	
			3/4	
			1	

ORDERING CODES

Code	Description	Code	Description	Code	Description
Skillair® 100 PADLOCKABLE REGULATOR		Skillair® 200 PADLOCKABLE REGULATOR		Skillair® 300 PADLOCKABLE REGULATOR	
3210001A	REG 100 KEY 02 without end plates	3410001A	REG 200 KEY 02 without end plates	4410000A	REG 300 KEY 02 without end plates
3210002A	REG 100 KEY 04 without end plates	3410002A	REG 200 KEY 04 without end plates	4410001A	REG 300 KEY 04 without end plates
3210003A	REG 100 KEY 08 without end plates	3410003A	REG 200 KEY 08 without end plates	4410002A	REG 300 KEY 08 without end plates
3210004A	REG 100 KEY 012 without end plates	3410004A	REG 200 KEY 012 without end plates	4410003A	REG 300 KEY 012 without end plates
3210001	REG 100 KEY 1/4 02	3410001	REG 200 KEY 1/4 02	4410000	REG 300 KEY 1/2 02
3210002	REG 100 KEY 1/4 04	3410002	REG 200 KEY 1/4 04	4410001	REG 300 KEY 1/2 04
3210003	REG 100 KEY 1/4 08	3410003	REG 200 KEY 1/4 08	4410002	REG 300 KEY 1/2 08
3210004	REG 100 KEY 1/4 012	3410004	REG 200 KEY 1/4 012	4410003	REG 300 KEY 1/2 012
3310001	REG 100 KEY 3/8 02	3510001	REG 200 KEY 3/8 02	4510000	REG 300 KEY 3/4 02
3310002	REG 100 KEY 3/8 04	3510002	REG 200 KEY 3/8 04	4510001	REG 300 KEY 3/4 04
3310003	REG 100 KEY 3/8 08	3510003	REG 200 KEY 3/8 08	4510002	REG 300 KEY 3/4 08
3310004	REG 100 KEY 3/8 012	3510004	REG 200 KEY 3/8 012	4510003	REG 300 KEY 3/4 012
		3610001	REG 200 KEY 1/2 02	4610000	REG 300 KEY 1 02
		3610002	REG 200 KEY 1/2 04	4610001	REG 300 KEY 1 04
		3610003	REG 200 KEY 1/2 08	4610002	REG 300 KEY 1 08
		3610004	REG 200 KEY 1/2 012	4610003	REG 300 KEY 1 012

UNITS

Skillair® PADLOCKABLE REGULATOR

Skillair® PILOT REGULATOR



The pilot regulator is used when great accuracy is required in maintaining the set pressure under changing operating conditions.

It is ideal for use as:

- a precision regulator for flow rates < 100 NI/min.
- a pilot in general - typically for large size regulators (see REG 400).

The system's high operating accuracy and low hysteresis are determined by the virtually total lack of friction.

The presence of a slight air leak is necessary for the regulator to operate properly - it is not a malfunction. It is advisable to use filtered air.



TECHNICAL DATA		PILOT REGULATOR	
Threaded port		1/4"	
Setting range	bar	0 to 2 - 0 to 4 - 0 to 8 - 0 to 12	
Max. input pressure	MPa	1.3	
	bar	13	
	psi	188	
Flow rate at 6.3 bar (0.63 MPa to 91 psi) ΔP 0.5 bar (0.05 MPa to 7 psi)		120 NI/min - 4.3 scfm	
Flow rate at 6.3 bar (0.63 MPa to 91 psi) ΔP 1 bar (0.1 MPa to 14 psi)		140 NI/min - 5 scfm	
Fluid		Filtered, lubricated or unlubricated compressed air. Lubrication, if used, must be continuous.	
Max temperature at 1 MPa; 10 bar; 145 psi	°C	50	
	°F	122	
Weight	kg	0.6	
Mounting position		In any position	
Pressure gauge port		G 1/8"	
Notes on use		The regulator pressure must always be set upwards. For increased sensitivity, use a pressure regulator with a rated pressure as close as possible to the required value. Do not take air from the pressure gauge ports. Mount directly on REG 400.	

COMPONENTS

- ① Aluminium body
- ② Technopolymer knob
- ③ OT58 brass adjusting screw
- ④ OT58 brass scroll
- ⑤ Technopolymer bell
- ⑥ Technopolymer ring nut
- ⑦ Steel adjusting spring
- ⑧ Rolling diaphragm
- ⑨ NBR relieving gaskets
- ⑩ OT58 brass stem
- ⑪ Stainless steel ball valve
- ⑫ Stainless steel valve spring
- ⑬ NBR gaskets

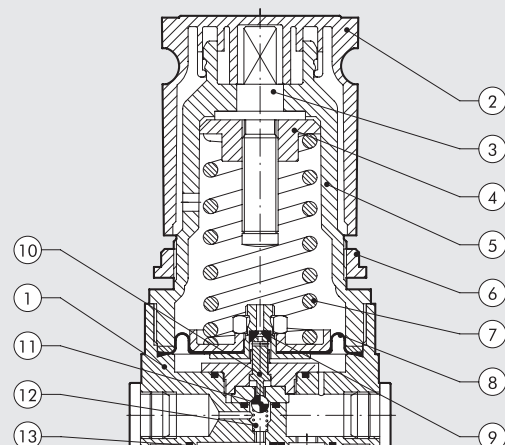

FLOW CHARTS

FLOW FEATURES REG. P 1/4"

Preset pressure
Pm = 7 bar - 0.7 MPa - 100 psi

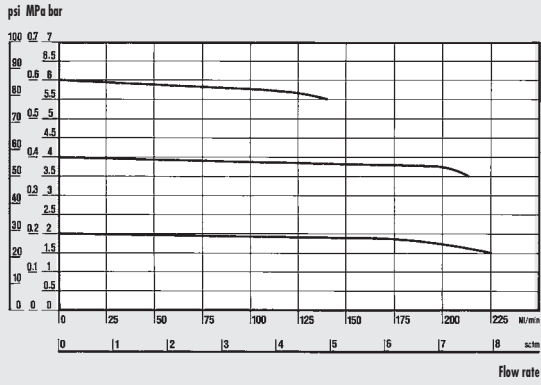

REGULATION FEATURES REG. P 1/4" *

Flow rate: A = 0 Nl/min = 0 scfm -
B = 25 Nl/min = 0.88 scfm - C = 50 Nl/min = 1.76 scfm

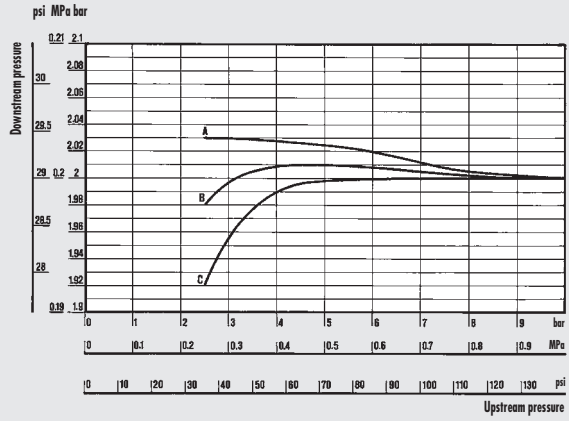

REGULATION FEATURES REG. P 1/4" *

Flow rate: A = 0 Nl/min = 0 scfm
B = 25 Nl/min = 0.88 scfm - C = 50 Nl/min = 1.76 scfm

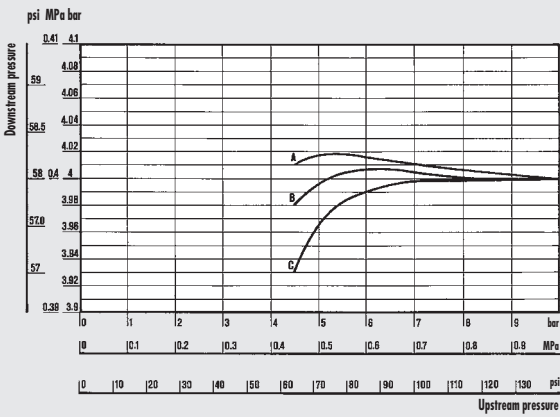

REGULATION FEATURES REG. P 1/4" *

Flow rate: A = 0 Nl/min = 0 scfm
B = 25 Nl/min = 0.88 scfm - C = 50 Nl/min = 1.76 scfm

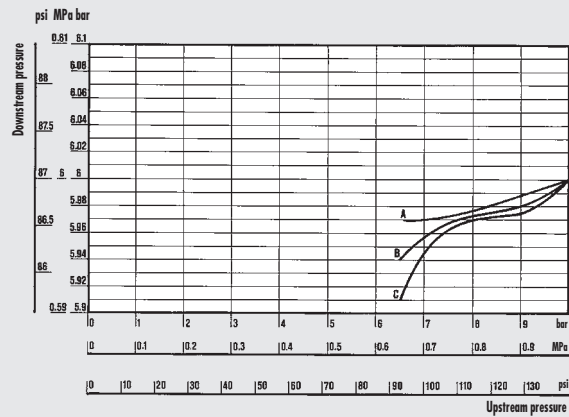

UNITS

Skillair® PILOT REGULATOR

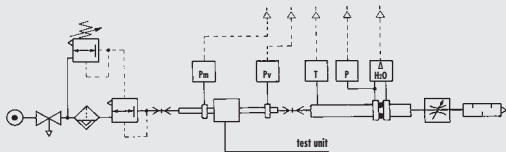

• Flow tests carried out at the Department of Mechanics, Turin Polytechnic, using the computerized test bench following CETOP RP50R recommendations (ISO DIS 6358-2-approved) with ISO 5167 diaphragm gauge.

* Pressure stability adjusted according to changes in upstream pressure.

DIMENSIONS

Code	Description
3206001	REG. P 1/4" O2
3206002	REG. P 1/4" O4
3206003	REG. P 1/4" O8
3206004	REG. P 1/4" O12

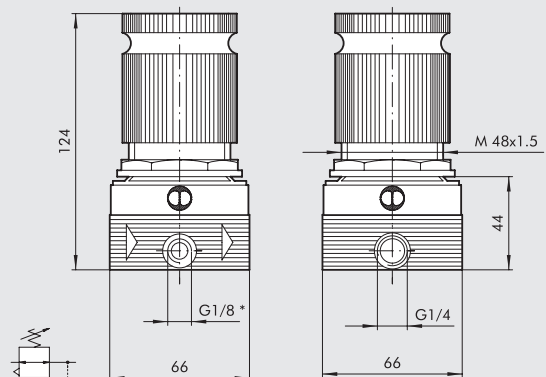

*Pressure gauge port

Skillair® PILOT PADLOCKABLE REGULATOR



The pilot regulator is used when great accuracy is required in maintaining the set pressure under changing operating conditions.

It is ideal for use as:

- a precision regulator for flow rates < 100 NI/min.
- a pilot in general - typically for large size regulators (see REG 400).

The system's high operating accuracy and low hysteresis are determined by the virtually total lack of friction. The presence of a slight air leak is necessary for the regulator to operate properly - it is not a malfunction.

It is advisable to use filtered air.

The pilot padlockable regulator has a pin with a hole in it that projects from the top of the knob. When the knob is in the push-lock position, the padlock can be inserted in the hole, preventing the knob from being operated.

A padlock and two keys are supplied with the regulator.

Refer to the pilot regulator for technical data and flow curves.



COMPONENTS

- ① Aluminium body
- ② Technopolymer knob
- ③ Nickel-plated brass OT58 adjusting screw
- ④ OT58 brass scroll
- ⑤ Technopolymer bell
- ⑥ Technopolymer ring nut
- ⑦ Steel adjusting spring
- ⑧ Rolling diaphragm
- ⑨ NBR relieving gaskets
- ⑩ OT58 brass stem
- ⑪ Stainless steel ball valve
- ⑫ Stainless steel valve spring
- ⑬ NBR gaskets
- ⑭ Padlock

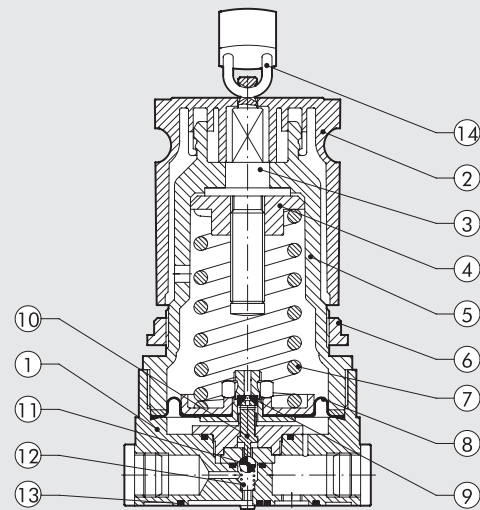

DIMENSIONS

Code	Description
3208001	REG. P KEY 1/4" 02
3208002	REG. P KEY 1/4" 04
3208003	REG. P KEY 1/4" 08
3208004	REG. P KEY 1/4" 012

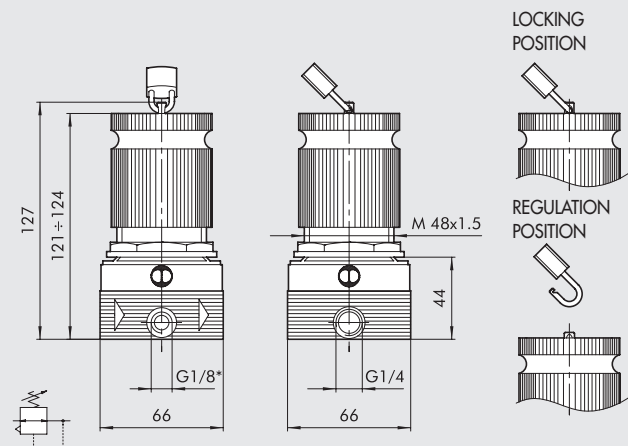

*Pressure gauge port

Skillair® 300 PILOT OPERATED REGULATOR

- Pilot-operated or servo-piloted regulator.
- Twin rolling diaphragm to ensure improved opening and hence greater flow rate.
- Low load losses
- Excellent precision in pressure setting.
- Excellent sensitivity during relieving.



UNITS

Skillair® 300 PILOT OPERATED REGULATOR

TECHNICAL DATA

		300 PILOT OPERATED REG		
		1/2"	3/4"	1"
Threaded port		1/2"	3/4"	1"
Setting range		Depending on the pilot regulator		
Max. input pressure	MPa		1.3	
	bar		13	
	psi		188	
Flow rate at 6.3 bar (0.63 MPa to 91 psi) ΔP 0.5 bar (0.05 MPa to 7 psi)	NI/min		4500	
	scfm		160	
Flow rate at 6.3 bar (0.63 MPa to 91 psi) ΔP 1 bar (0.1 MPa to 14 psi)	NI/min		7000	
	scfm		247	
Fluid		Filtered, lubricated or unlubricated compressed air. Lubrication, if used, must be continuous.		
Max temperature at 1 MPa; 10 bar; 145 psi	°C		50	
	°F		122	
Weight	kg		1.3	
Wall fixing screws			M5 x 70	
Mounting position			In any position	
Pressure gauge port			1/8"	
Notes on use		The regulator pressure must always be set upwards. Do not take air from the pressure gauge ports.		

DIMENSIONS

Threaded port G A	REG 300		
	1/2"	3/4"	1"
A	110	110	112

ORDERING CODES

Code	Description
4403003A	300 pilot operated reg without end plates
4403003	300 1/2" pilot operated reg
4503003	300 3/4" pilot operated reg
4603003	300 1" pilot operated reg

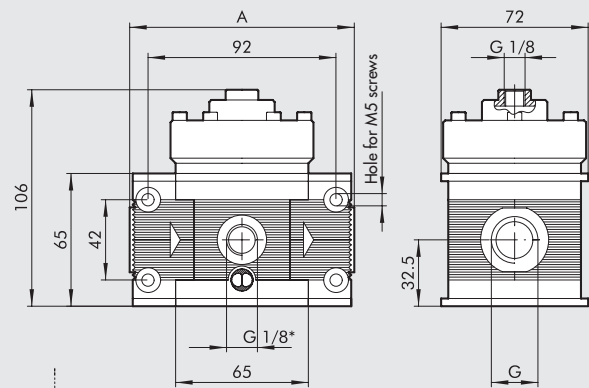

*Pressure gauge port

Skillair® FILTER REGULATOR



This device combines a filter and a pressure regulator in a single unit. It has the dual function of filtering and regulating air from the compressor. As the filter regulator is made up of the same elements as the regulator and the filter, the performance is the same.

- High flow rates with low load loss.
- Special rolling diaphragm - higher flow rate, greater stability, improved sensitivity.
- Rapid relief of downstream overpressures.
- Stability of the regulated pressure as the mains pressure fluctuates.
- Maximum degree of condensate separation.
- 360° condensate level display.
- Condensate drain with manual/semi-automatic or automatic function.



TECHNICAL DATA	FR 100		FR 200			FR 300		
	1/4"	3/8"	1/4"	3/8"	1/2"	1/2"	3/4"	1"
Threaded port	1/4"	3/8"	1/4"	3/8"	1/2"	1/2"	3/4"	1"
Setting range	0 to 2 - 0 to 4 - 0 to 8 - 0 to 12		0 to 2 - 0 to 4 - 0 to 8 - 0 to 12			0 to 2 - 0 to 4 - 0 to 8 - 0 to 12		
Degree of filtration	5 - 20 - 50		5 - 20 - 50			5 - 20 - 50		
Max. input pressure	1.5 MPa - 15 bar - 217 psi		1.3 MPa - 13 bar - 188 psi			1.3 MPa - 13 bar - 188 psi		
Flow rate at 6.3 bar (0.63 MPa to 91 psi)	Nl/min	1100	1600			3500		
ΔP 0.5 bar (0.05 MPa to 7psi)	scfm	39	57			125		
Flow rate at 6.3 bar (0.63 MPa to 91 psi)	Nl/min	1600	3000			5600		
ΔP 1 bar (0.1 MPa to 14 psi)	scfm	57	71			200		
Max temperature	°C	50	50			50		
at: 1 MPa; 10 bar; 145 psi	°F	122	122			122		
Weight	kg	0.5	1			1.8		
Wall fixing screws	M4 x 50		M5 x 60			M5 x 70		
Mounting position	Vertical		Vertical			Vertical		
Pressure gauge port	1/8"		1/8"			1/8"		
Bowl capacity	cm ³	22	45			75		
Drain	RMSA - SAC		RMSA - SAC - RA			RMSA - RA		
RMSA: drain with manual condensate discharge and automatic discharge at zero pressure RA: automatic drain with condensate discharge, independent of pressure and flow rate. Version conveys the draining by inserting the pipe having internal diameter 6 mm in the lower port. SAC: automatic drain with condensate discharge. Operates by pressure drop – requires variable air take-offs. Filtered, lubricated or unlubricated compressed air. Lubrication, if used, must be continuous. The regulator pressure must always be set upwards. For increased sensitivity, use a pressure regulator with a rated pressure as close as possible to the required value. Do not take air from pressure gauge ports. The maximum inlet pressure for the version with RA automatic condensate drainage must not exceed 10 bar.								
Fluid								
Notes on use								

COMPONENTS

- ① Technopolymer body
- ② Technopolymer knob
- ③ OT58 brass adjusting screw
- ④ OT58 brass scroll
- ⑤ Technopolymer bell
- ⑥ Steel adjusting spring
- ⑦ Technopolymer ring nut
- ⑧ Rolling diaphragm
- ⑨ NBR relieving gaskets
- ⑩ OT58 brass stem
- ⑪ Valve with NBR vulcanized gasket
- ⑫ Stainless steel valve spring
- ⑬ Technopolymer centrifuge
- ⑭ Technopolymer baffle plug
- ⑮ Technopolymer screen
- ⑯ Sintered HDPE filter cartridge
- ⑰ Clear technopolymer glass
- ⑱ Bowl: technopolymer for FR100 and FR200, metal for FR 300
- ⑲ Drain (RMSA)
- ⑳ Zamak end plate
- ㉑ NBR gaskets

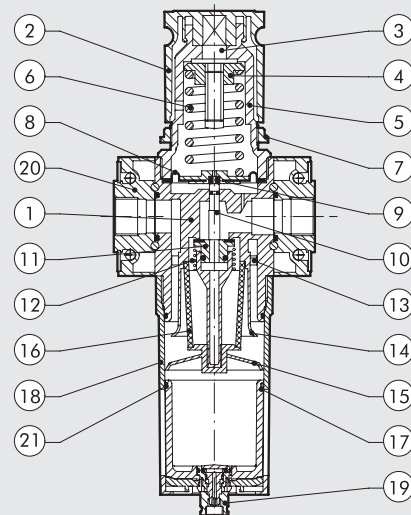

FLOW CHARTS

FR 100 1/4 - 3/8

Preset pressure
Pm = 7 bar - 0.7 MPa - 100 psi
psi MPa bar

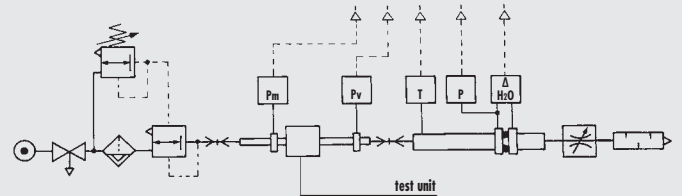
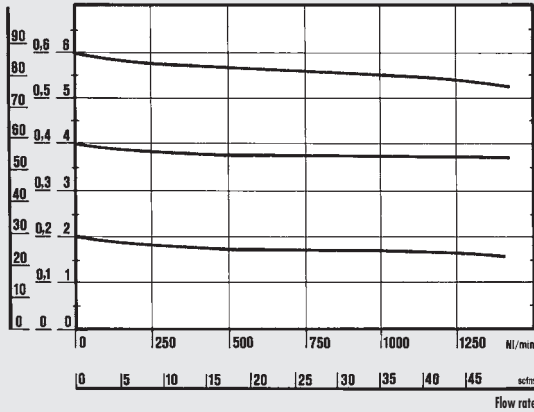

• Flow tests carried out at the Department of Mechanics, Turin Polytechnic, using the computerized test bench following CETOP RP50R recommendations (ISO DIS 6358-2-approved) with ISO 5167 diaphragm gauge.

FR 200 1/4 - 3/8 - 1/2

Preset pressure
Pm = 7 bar - 0.7 MPa - 100 psi
psi MPa bar

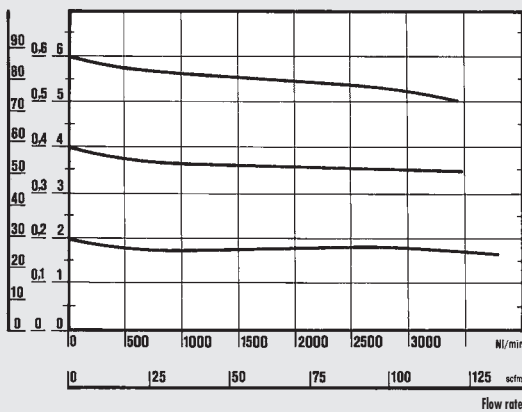

FR 300 1/2 - 3/4 - 1

Preset pressure
Pm = 7 bar - 0.7 MPa - 100 psi
psi MPa bar

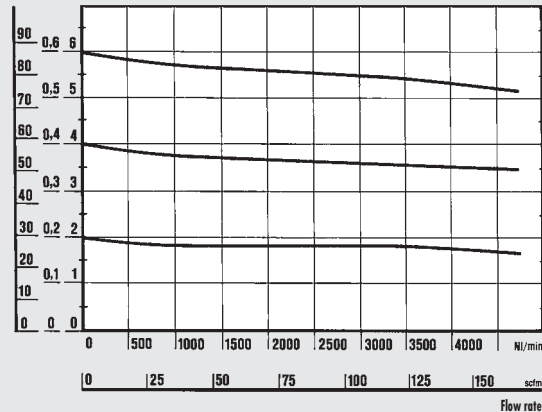

UNITS

Skillair® FILTER REGULATOR

DIMENSIONS

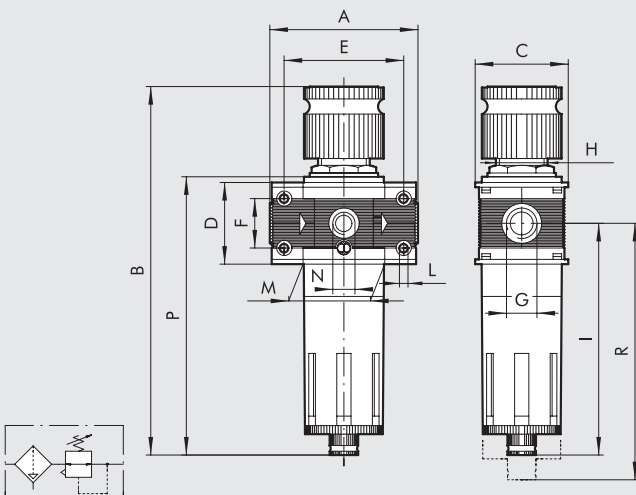

	FR 100		FR 200			FR 300		
Threaded port G	1/4"	3/8"	1/4"	3/8"	1/2"	1/2"	3/4"	1"
A	78		93.5			110		112
B		RMSA	199		245			278
		RA	-		249			282
		SAC	203		249			282
C	50		63			72		
D	43		55			65		
E	63		78.5			92		
F	26		36			42		
H	30 x 1.5		40x1.5			48 x 1.5		
I	122.5		147.5			162.5		
L		Hole for M4		Hole for M5			Hole for M5	
		screws		screws			screws	
M	43		55.5			65		
N (pressure gauge port)	1/8"		1/8"			1/8"		
P		RMSA	147		178			200
		RA	-		182			204
		SAC	151		182			204
R		RMSA	137		196			215
		RA	-		200			219
		SAC	141		200			219

SYNOPTIC, SIZES AND VERSIONS

FR	100	1/4	5	02	RMSA
ELEMENT	SIZE	THREADED PORT	DEGREE OF FILTRATION	SETTING RANGE	TYPE OF DRAIN
FR	100	1/4	5 = 5 µm 20 = 20 µm 50 = 50 µm	02 = 0 to 2 bar 04 = 0 to 4 bar 08 = 0 to 8 bar 012 = 0 to 12 bar	RMSA
		3/8			SAC
		1/4			RMSA
	200	3/8	1/2	SAC	RA*
		1/2		RMSA	
		3/4		RA	
	300	1			

RMSA: drain with manual condensate discharge and automatic discharge at zero pressure.
 RA: automatic drain with condensate discharge, independent of pressure and flow rate. (for size 300 and 400).
 Version conveys the draining by inserting the pipe having internal diameter 6 mm in the lower port.
 SAC: automatic drain with condensate discharge.
Operates by pressure drop – requires variable air take-offs.
 (for size 100 and 200)
 * For Skillair® 200 with RA, please contact our sales assistance department.

ORDERING CODES

Code	Description	Code	Description	Code	Description
Skillair® 100 FILTER REGULATOR		Skillair® 200 FILTER REGULATOR		Skillair® 300 FILTER REGULATOR	
3283007A	FR 100 5 08 RMSA without end plates	3483007A	FR 200 5 08 RMSA without end plates	4483004A	FR 300 5 08 RMSA without end plates
3283008A	FR 100 20 08 RMSA without end plates	3483008A	FR 200 20 08 RMSA without end plates	4483005A	FR 300 20 08 RMSA without end plates
3283009A	FR 100 50 08 RMSA without end plates	3483009A	FR 200 50 08 RMSA without end plates	4483006A	FR 300 50 08 RMSA without end plates
3283010A	FR 100 5 012 RMSA without end plates	3483010A	FR 200 5 012 RMSA without end plates	4483007A	FR 300 5 012 RMSA without end plates
3283011A	FR 100 20 012 RMSA without end plates	3483011A	FR 200 20 012 RMSA without end plates	4483008A	FR 300 20 012 RMSA without end plates
3283012A	FR 100 50 012 RMSA without end plates	3483012A	FR 200 50 012 RMSA without end plates	4483009A	FR 300 50 012 RMSA without end plates
3283031A	FR 100 5 08 SAC without end plates	3483031A	FR 200 5 08 SAC without end plates	4483013A	FR 300 5 08 RA without end plates
3283032A	FR 100 20 08 SAC without end plates	3483032A	FR 200 20 08 SAC without end plates	4483014A	FR 300 20 08 RA without end plates
3283033A	FR 100 50 08 SAC without end plates	3483033A	FR 200 50 08 SAC without end plates	4483015A	FR 300 50 08 RA without end plates
3283034A	FR 100 5 012 SAC without end plates	3483034A	FR 200 5 012 SAC without end plates	4483016A	FR 300 5 012 RA without end plates
3283035A	FR 100 20 012 SAC without end plates	3483035A	FR 200 20 012 SAC without end plates	4483017A	FR 300 20 012 RA without end plates
3283036A	FR 100 50 012 SAC without end plates	3483036A	FR 200 50 012 SAC without end plates	4483018A	FR 300 50 012 RA without end plates
3283007	FR 100 1/4 5 08 RMSA	3483007	FR 200 1/4 5 08 RMSA	4483004	FR 300 1/2 5 08 RMSA
3283008	FR 100 1/4 20 08 RMSA	3483008	FR 200 1/4 20 08 RMSA	4483005	FR 300 1/2 20 08 RMSA
3283009	FR 100 1/4 50 08 RMSA	3483009	FR 200 1/4 50 08 RMSA	4483006	FR 300 1/2 50 08 RMSA
3283010	FR 100 1/4 5 012 RMSA	3483010	FR 200 1/4 5 012 RMSA	4483007	FR 300 1/2 5 012 RMSA
3283011	FR 100 1/4 20 012 RMSA	3483011	FR 200 1/4 20 012 RMSA	4483008	FR 300 1/2 20 012 RMSA
3283012	FR 100 1/4 50 012 RMSA	3483012	FR 200 1/4 50 012 RMSA	4483009	FR 300 1/2 50 012 RMSA
3283031	FR 100 1/4 5 08 SAC	3483031	FR 200 1/4 5 08 SAC	4483013	FR 300 1/2 5 08 RA
3283032	FR 100 1/4 20 08 SAC	3483032	FR 200 1/4 20 08 SAC	4483014	FR 300 1/2 20 08 RA
3283033	FR 100 1/4 50 08 SAC	3483033	FR 200 1/4 50 08 SAC	4483015	FR 300 1/2 50 08 RA
3283034	FR 100 1/4 5 012 SAC	3483034	FR 200 1/4 5 012 SAC	4483016	FR 300 1/2 5 012 RA
3283035	FR 100 1/4 20 012 SAC	3483035	FR 200 1/4 20 012 SAC	4483017	FR 300 1/2 20 012 RA
3283036	FR 100 1/4 50 012 SAC	3483036	FR 200 1/4 50 012 SAC	4483018	FR 300 1/2 50 012 RA
3383007	FR 100 3/8 5 08 RMSA	3583007	FR 200 3/8 5 08 RMSA	4583004	FR 300 3/4 5 08 RMSA
3383008	FR 100 3/8 20 08 RMSA	3583008	FR 200 3/8 20 08 RMSA	4583005	FR 300 3/4 20 08 RMSA
3383009	FR 100 3/8 50 08 RMSA	3583009	FR 200 3/8 50 08 RMSA	4583006	FR 300 3/4 50 08 RMSA
3383010	FR 100 3/8 5 012 RMSA	3583010	FR 200 3/8 5 012 RMSA	4583007	FR 300 3/4 5 012 RMSA
3383011	FR 100 3/8 20 012 RMSA	3583011	FR 200 3/8 20 012 RMSA	4583008	FR 300 3/4 20 012 RMSA
3383012	FR 100 3/8 50 012 RMSA	3583012	FR 200 3/8 50 012 RMSA	4583009	FR 300 3/4 50 012 RMSA
3383031	FR 100 3/8 5 08 SAC	3583031	FR 200 3/8 5 08 SAC	4583013	FR 300 3/4 5 08 RA
3383032	FR 100 3/8 20 08 SAC	3583032	FR 200 3/8 20 08 SAC	4583014	FR 300 3/4 20 08 RA
3383033	FR 100 3/8 50 08 SAC	3583033	FR 200 3/8 50 08 SAC	4583015	FR 300 3/4 50 08 RA
3383034	FR 100 3/8 5 012 SAC	3583034	FR 200 3/8 5 012 SAC	4583016	FR 300 3/4 5 012 RA
3383035	FR 100 3/8 20 012 SAC	3583035	FR 200 3/8 20 012 SAC	4583017	FR 300 3/4 20 012 RA
3383036	FR 100 3/8 50 012 SAC	3583036	FR 200 3/8 50 012 SAC	4583018	FR 300 3/4 50 012 RA
		3683007	FR 200 1/2 5 08 RMSA	4683004	FR 300 1 5 08 RMSA
		3683008	FR 200 1/2 20 08 RMSA	4683005	FR 300 1 20 08 RMSA
		3683009	FR 200 1/2 50 08 RMSA	4683006	FR 300 1 50 08 RMSA
		3683010	FR 200 1/2 5 012 RMSA	4683007	FR 300 1 5 012 RMSA
		3683011	FR 200 1/2 20 012 RMSA	4683008	FR 300 1 20 012 RMSA
		3683012	FR 200 1/2 50 012 RMSA	4683009	FR 300 1 50 012 RMSA
		3683031	FR 200 1/2 5 08 SAC	4683013	FR 300 1 5 08 RA
		3683032	FR 200 1/2 20 08 SAC	4683014	FR 300 1 20 08 RA
		3683033	FR 200 1/2 50 08 SAC	4683015	FR 300 1 50 08 RA
		3683034	FR 200 1/2 5 012 SAC	4683016	FR 300 1 5 012 RA
		3683035	FR 200 1/2 20 012 SAC	4683017	FR 300 1 20 012 RA
		3683036	FR 200 1/2 50 012 SAC	4683018	FR 300 1 50 012 RA

UNITS
Skillair® FILTER REGULATOR

Skillair® LUBRICATOR

The pneumatic lubricator is the simplest way of properly lubricating actuators connected to a circuit.

As air flows from the mains through the lubricator, it encounters the diaphragm which obstructs the flow and the air is forced through the Venturi tube.

The inside of the Venturi tube is connected to the inspection dome, which connects with the bowl via a tube with a regulating needle in between.

The drop in pressure caused by the Venturi tube sucks up air through the dome, the tube and lastly into the bowl containing oil.

The quantity of oil controlled by the regulating needle then flows back from the bowl to the circuit.



UNITS

Skillair® LUBRICATOR

TECHNICAL DATA	LUB 100		LUB 200			LUB 300			LUB 400				
	1/4"	3/8"	1/4"	3/8"	1/2"	1/2"	3/4"	1"	1"	1 1/4"	1 1/2"	2"	
Threaded port													
Type of lubrication	Mist		Mist			Mist			Mist				
Bowl capacity	50		95			160			800				
Versions	Standard - CD		Standard - CD			Standard - CD - ML CD			Standard - CD - ML CD				
Max. inlet pressure	Mpa	1.5	1.3			1.3			1.3		1.3		1.3
	bar	15	13			13			13		13		13
	psi	217	188			188			188		188		188
Flow rate at 6.3 bar (0.63 MPa to 91 psi)	Nl/min	1100	2200			3500			18000		21000		
ΔP 0.5 bar (0.05 MPa to 7 psi)	scfm	39	71			125			640		750		
Flow rate at 6.3 bar (0.63 MPa to 91 psi)	Nl/min	1500	3700			5500			-		-		
ΔP 1 bar (0.1 MPa to 14 psi)	scfm	53	131			196			-		-		
Max temperature at: 1 MPa; 10 bar; 145 psi	°C	50	50			50			50		50		50
	°F	122	122			122			122		122		122
Weight	Kg	0.4	0.7			1.4			4.9		5.7		
Wall fixing screws		M4 x 50		M5 x 60			M5 x 70			M6 x 110		M6 x 110	
Mounting position		Vertical											
Fluid		Filtered compressed air											
Recommended oils		ISO and UNI FD22 (Energol HPL to Spinesso to Mobil DTE to Tellus Oil).											
Notes on use		Install the lubricator as close as possible to the point of use. Fill the lubricator bowl with oil before pressurizing the system. Do not use cleaning oils, brake fluid oils or solvents in general. For the best lubrication results, set the drip rate to one drop per 300-600 Nl.											

COMPONENTS LUB 100 - LUB 200 - LUB 300

- ① Technopolymer body
- ② Bowl: technopolymer for LUB 100 and 200, metal for LUB 300
- ③ Technopolymer plug
- ④ Clear technopolymer glass
- ⑤ NBR Venturi tube diaphragm
- ⑥ Rilsan® oil suction tube
- ⑦ Filter
- ⑧ Clear technopolymer inspection dome
- ⑨ OT58 brass oil flow regulating needle
- ⑩ OT58 brass oil filling plug
- ⑪ Zamak end plate
- ⑫ NBR gaskets

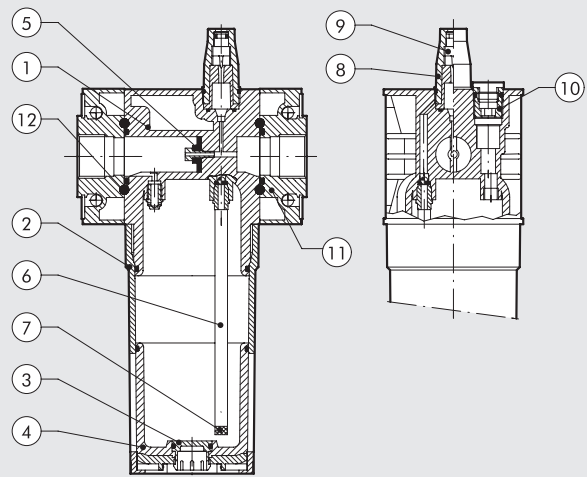

COMPONENTS LUB 400

- ① Aluminium body
- ② Aluminium bowl
- ③ Clear technopolymer glass
- ④ NBR Venturi tube diaphragm
- ⑤ Aluminium end plate
- ⑥ OT58 brass retaining ring
- ⑦ Anodized aluminium threaded bush, axial adjustment
- ⑧ Rilsan® oil suction pipe
- ⑨ Filter
- ⑩ Technopolymer plug
- ⑪ Clear technopolymer inspection dome
- ⑫ OT58 brass oil flow regulating needle
- ⑬ OT58 brass oil filling plug
- ⑭ NBR gaskets

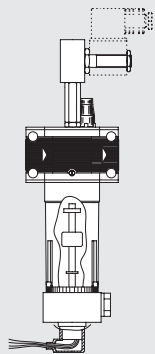
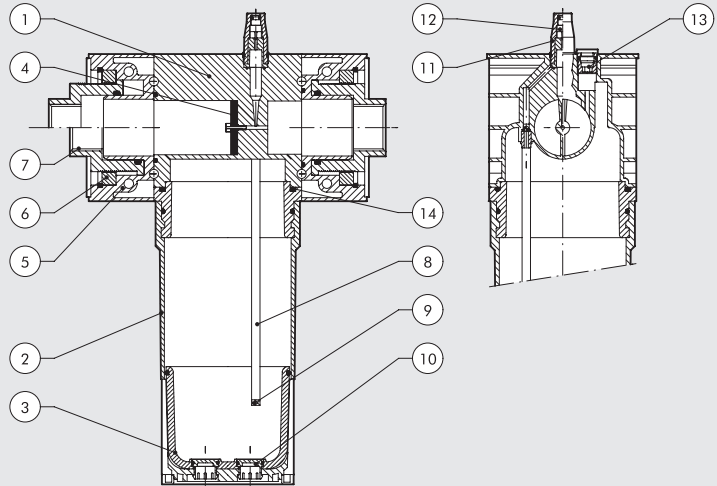

PRESSURE DROP FILLING WITH MINIMUM LEVEL (ML CD AUTOMATIC)

Available in sizes 300 and 400, this lubricator is controlled by a solenoid valve (2/2 NC minimum bore 3) situated on the lubricator body. It reduces pressure inside the bowl allow it to be filled with oil taken from a tank at ambient pressure, which can be located in a lower position than the lubricator (max. difference in height 2 m). The electric indicator inside the bowl sends an electric signal used to activate the valve. When the oil reaches the maximum level, another signal disactivates the valve. In this case, the lubricator system operates with the oil level between minimum and maximum. If it is necessary to keep the oil level in the bowl constant, only one of the two signals can be used. Pressure range 3-10 bar. Connect the oil tank to the G1/4 fitting on the bowl. **N.B.:** for coils and connectors see Skillair accessories.

Constant minimum level

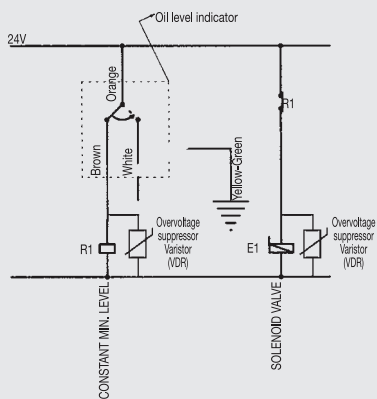

Constant maximum level

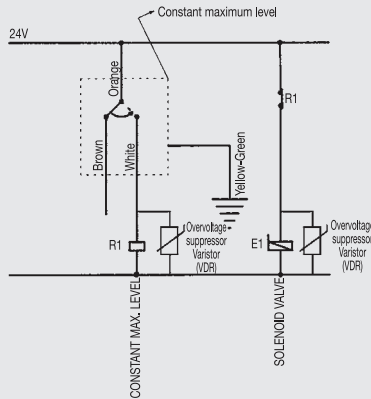

Oil level between maximum and minimum

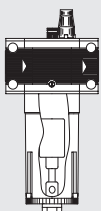
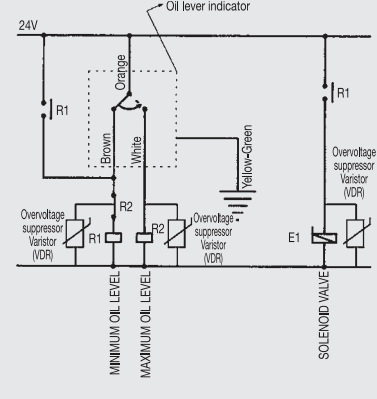

FILLING BY PRESSURE DROP (CD MANUAL)

Available in all sizes. It is operated by means of a button on the lubricator body. The pressure inside the bowl drops to allow it to be filled with oil taken from a tank at ambient pressure, which can be located in a lower position than the lubricator (max. difference in height 2 m). Oil filling stops when the level of oil raises the float and shuts off a specific valve. Important - The SK4 lubricator is filled with oil by hand. Filling must stop when the oil level is visible through the spy-hole in the bowl release lever. Pressure range 3-10 bar. Lubrication is discontinued during filling. Connect the oil tank to the G1/4 fitting below the bowl.

FLOW CHARTS

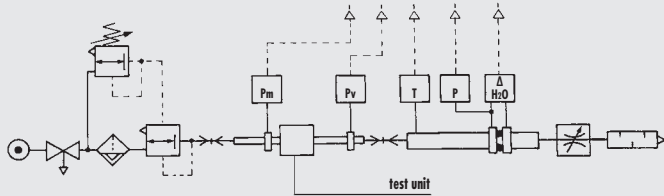

• Flow tests carried out at the Department of Mechanics, Turin Polytechnic, using the computerized test bench following CETOP RP50R recommendations (ISO DIS 6358-2-approved) with ISO 5167 diaphragm gauge.

- (A) = 2 bar - 0.2 MPa - 29 psi
- (B) = 4 bar - 0.4 MPa - 58 psi
- (C) = 6 bar - 0.6 MPa - 87 psi
- (D) = 8 bar - 0.8 MPa - 116 psi
- (E) = 10 bar - 1 MPa - 145 psi

LUB 100 1/4 - 3/8

$\Delta P = (P_m - P_v)$
psi kPa bar

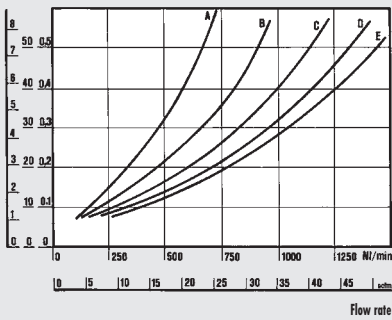

MINIMUM OPERATING FLOW CHART

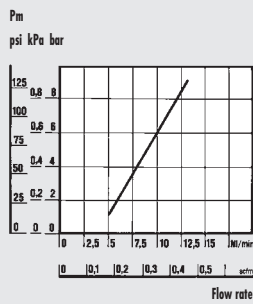

LUB 400 1"

$\Delta P = (P_m - P_v)$
psi kPa bar

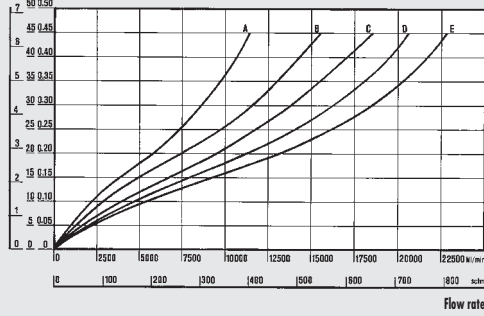

LUB 200 1/4 - 3/8 - 1/2

$\Delta P = (P_m - P_v)$
psi kPa bar

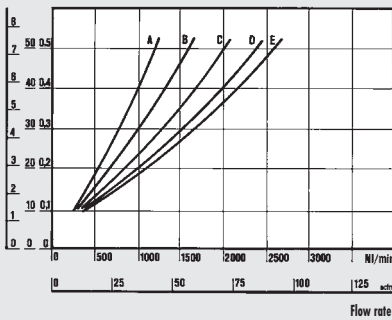

MINIMUM OPERATING FLOW CHART

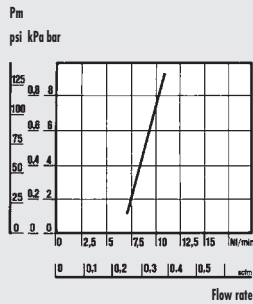

LUB 400 2"

$\Delta P = (P_m - P_v)$
psi kPa bar

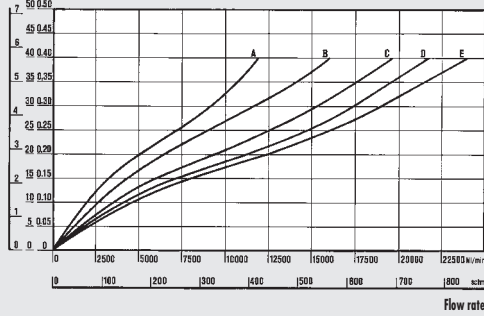

LUB 300 1/2 - 3/4 - 1

$\Delta P = (P_m - P_v)$
psi kPa bar

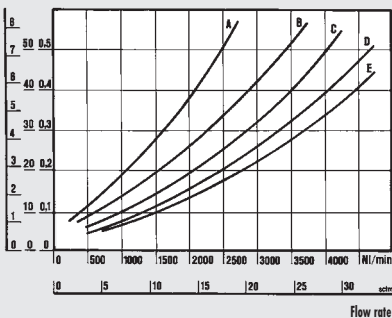

MINIMUM OPERATING FLOW CHART

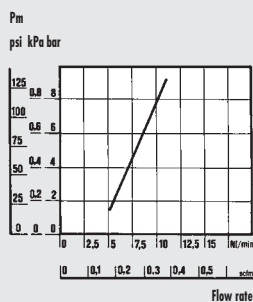

MINIMUM OPERATING FLOW CHART LUB 400 1" AND 2"

PRESSURE
psi kPa bar

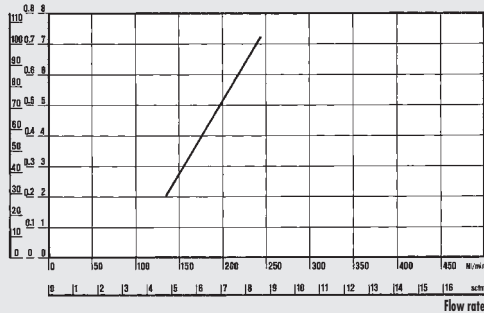

DIMENSIONS

100 - 200 - 300

400

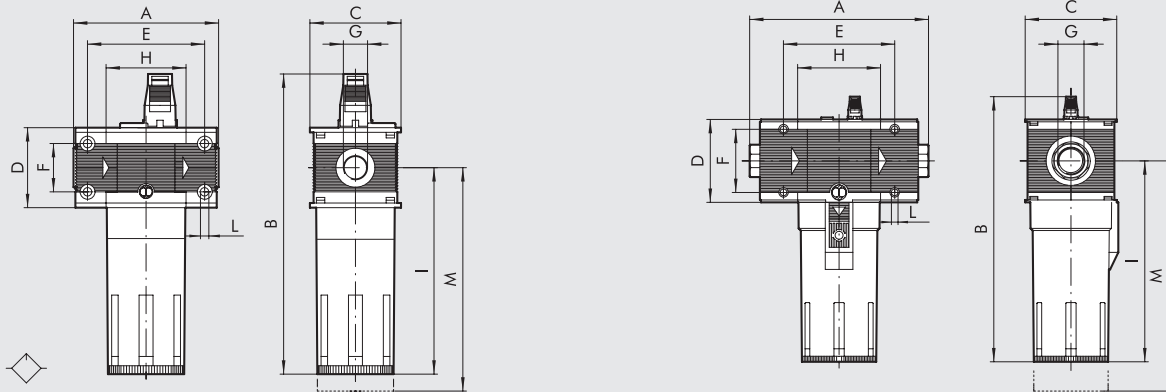

	LUB 100		LUB 200			LUB 300			LUB 400			
Threaded port G	1/4"	3/8"	1/4"	3/8"	1/2"	1/2"	3/4"	1"	1"	1 1/4"	1 1/2"	2"
A	78		93.5			110		112	225 to 255			
B	162		193			214			338			
C	50		63			72			118			
D	43		55			65			105			
E	63		78.5			92			141.4			
F	26		36			42			80			
H	43		55.5			65			105.4			
I	112		137.5			153			256			
L	Hole for M4 screws		Hole for M5 screws			Hole for M5 screws			Hole for M6 screws			
M	130		150			160			285			

SYNOPTIC, SIZES AND VERSIONS

LUB ELEMENT	100 SIZE	1/4 THREADED PORT	- TYPE OF OIL FILLING
LUB	100	1/4	- = STD
	200	3/8	ML-CD = AUTOMATIC
		1/4	CD = MANUAL
		3/8	
	300	1/2	
		1/2	
		3/4	
	400	1	
		1	
		1 1/4	
		1 1/2	
		2	

STD: Standard version filled with oil by removing the bowl or through the top cap. Requires circuit relieving.
 ML CD: Pressure drop filling with minimum level and valve
 CD MANUAL: Filling by pressure drop.

ORDERING CODES

Code	Description	Code	Description	Code	Description
Skillair® 100 LUBRICATOR		Skillair® 300 LUBRICATOR		Skillair® 400 LUBRICATOR	
3281001A	LUB 100 without end plates	4481001A	LUB 300 without end plates	6181001A	LUB 400 without end plates
3281005A	LUB 100 CD manual without end plates	4481005A	LUB 300 CD manual without end plates	6181004A	LUB 400 CD manual without end plates
3281001	LUB 100 1/4	4481006A	LUB 300 ML-CD automatic without end plates	6181006A	LUB 400 ML-CD automatic without end plates
3281005	LUB 100 1/4 CD manual	4481001	LUB 300 1/2	6181001	LUB 400 1
3381001	LUB 100 3/8	4481005	LUB 300 1/2 CD manual	6181004	LUB 400 1 CD manual
3381005	LUB 100 3/8 CD manual	4481006	LUB 300 1/2 ML-CD automatic	6181006	LUB 400 1 ML-CD automatic
Skillair® 200 LUBRICATOR		4581001	LUB 300 3/4	6281001	LUB 400 1 1/4
3481001A	LUB 200 without end plates	4581005	LUB 300 3/4 CD manual	6281004	LUB 400 1 1/4 CD manual
3481005A	LUB 200 CD manual without end plates	4581006	LUB 300 3/4 ML-CD automatic	6281006	LUB 400 1 1/4 ML-CD automatic
3481001	LUB 200 1/4	4681001	LUB 300 1	6381001	LUB 400 1 1/2
3481005	LUB 200 1/4 CD manual	4681005	LUB 300 1 CD manual	6381004	LUB 400 1 1/2 CD manual
3581001	LUB 200 3/8	4681006	LUB 300 1 ML-CD automatic	6381006	LUB 400 1 1/2 ML-CD automatic
3581005	LUB 200 3/8 CD manual			6481001	LUB 400 2
3681001	LUB 200 1/2			6481004	LUB 400 2 CD manual
3681005	LUB 200 1/2 CD manual			6481006	LUB 400 2 ML-CD automatic

Skillair® SHUT-OFF VALVE

The job of this valve is to make the circuit independent from the air supply. It is basically a three-way valve. In the closed position, it cuts off the air supply and discharges the downstream circuit at the same time, which means it is particularly useful during servicing operations. The hand-operated version can be padlocked to lock the knob in a closed position so that it can only be opened by someone with the right key. An interlocked version is available for low pressure operation.

N.B.: With size 400, when the V3V is mounted upstream of the regulator, the pilot regulator must be piloted at a pressure taken upstream of the V3V, otherwise when the system is relieved, most of the air downstream will be relieved by the regulator and not the V3V relief port. For connecting instruction see page C3.23



TECHNICAL DATA		V3V 100		V3V 200			V3V 300			V3V 400			
Threaded port		1/4"	3/8"	1/4"	3/8"	1/2"	1/2"	3/4"	1"	1"	1 1/4"	1 1/2"	2"
Min. inlet pressure for solenoid version **	MPa	0.3		0.3				0.2			0.3		0.3
	bar	3		3				2			3		3
	psi	43.5		43.5				29			43.5		43.5
Max. input pressure*	MPa	1.5		1.3				1.3			1.3		1.3
	bar	15		13				13			13		13
	psi	217		188				188			188		188
Flow rate at 6.3 bar (0.63 MPa to 91 psi)	Nl/min	1300		2400				3200			13000		14000
ΔP 0.5 bar (0.05 MPa to 7 psi)	scfm	46		85				113			460		494
Flow rate at 6.3 bar (0.63 MPa to 91 psi)	Nl/min	1650		3000				4700			-		-
ΔP 1 bar (0.1 MPa to 14 psi)	scfm	58		106				166			-		-
Max temperature	°C	50		50				50			50		50
	°F	122		122				122			122		122
Weight	kg	~ 0.5		~ 0.8				~ 1.2			4.8		5.6
Wall fixing screws		M4 x 50		M5 x 60				M5 x 70			M6 x 110		M6 x 110
Type of control		Manual - Pneumatic - Solenoid						Manual - Pneumatic - Solenoid					
		Solenoid pilot-assisted						Solenoid pilot-assisted - Key-operated					
Mounting position		In any position.											
Fluid		Filtered, lubricated or unlubricated compressed air. Lubrication, if used, must be continuous.											
Note		* 1 MPa - 10 bar - 145 psi for solenoid version											
		** 0.01 MPa - 0.1 bar - 1.45 psi for manual, pneumatic and pilot-assisted versions with controls min. 0.3 MPa 3 bar 43.5 psi.											

COMPONENTS

- ① Technopolymer body
- ② Operating button
- ③ Technopolymer knob
- ④ Stainless steel safety lamination
- ⑤ Locking unit
- ⑥ OT58 brass piston rod
- ⑦ Anodized aluminium top plug
- ⑧ Zamak end plate
- ⑨ Valve with vulcanized NBR gasket
- ⑩ Anodized aluminium bottom plug
- ⑪ Stainless steel valve spring
- ⑫ NBR gaskets

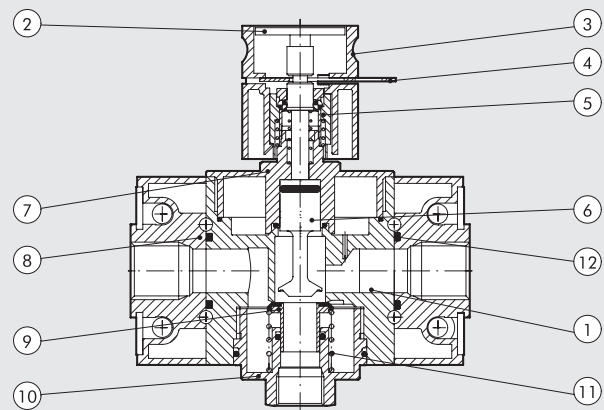

DIMENSIONS OF V3V MANUAL VERSION

100 - 200 - 300 LOCKABLE

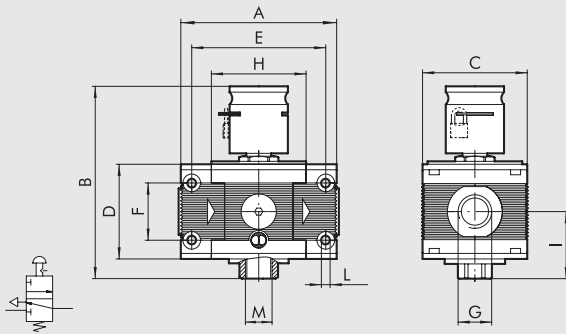

400 LOCKABLE

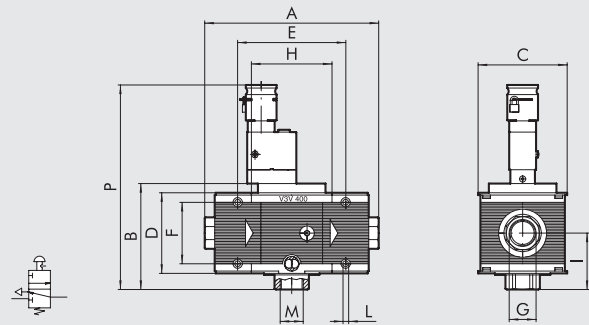

400 KEY-OPERATED

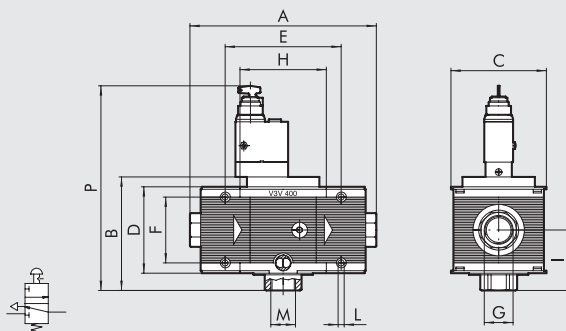

	V3V 100		V3V 200			V3V 300			V3V 400			
Threaded port G	1/4"	3/8"	1/4"	3/8"	1/2"	1/2"	3/4"	1"	1"	1 1/4"	1 1/2"	2"
A	78			93.5		110		112	225 to 255			283 to 313
B	106			119			132		137			
C	50			63			72		118			
D	43			55			65		105			
E	63			78.5			92		141.4			
F	26			36			42		80			
H	43			55.5			65		105.4			
I	33.5			40			46.5		72.5			
L	Hole for M4 screws		Hole for M5 screws			Hole for M5 screws			Hole for M6 screws			
M (relief)	1/8"		1/4"			3/8"			1"			
P manual	-		-			-			266			
key-operated	-		-			-			249			

DIMENSIONS OF V3V PNEUMATIC VERSION

100

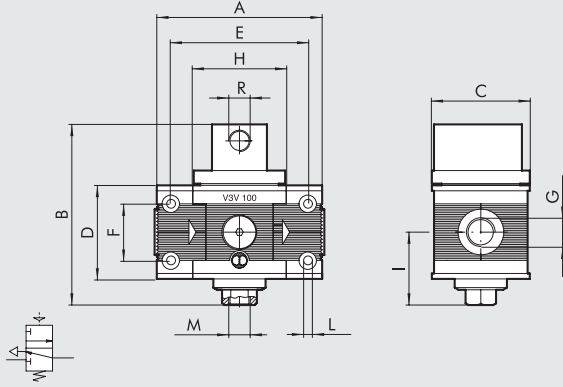

200

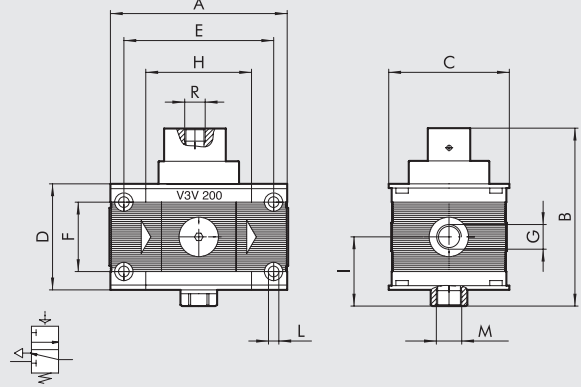

300

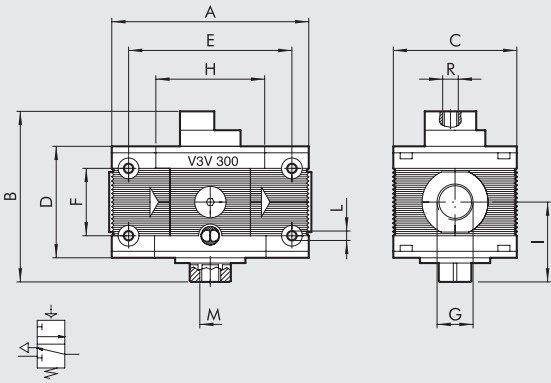

400

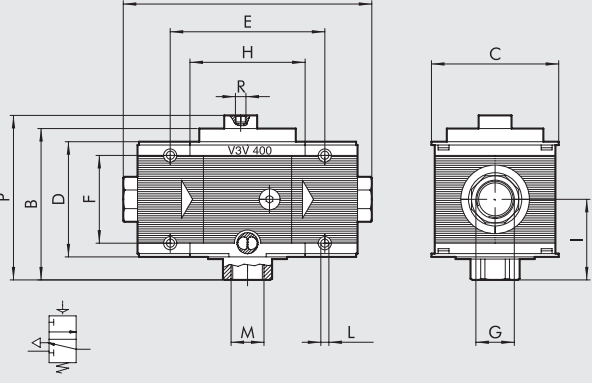

UNITS

Skilair® SHUT-OFF VALVE

	V3V 100		V3V 200			V3V 300			V3V 400			
Threaded port G	1/4"	3/8"	1/4"	3/8"	1/2"	1/2"	3/4"	1"	1"	1 1/4"	1 1/2"	2"
A	78		93.5			110		112	225 to 255			
B	83		96			106		137				
C	50		63			72		118				
D	43		55			65		105				
E	63		78.5			92		141.4				
F	26		36			42		80				
H	43		55.5			65		105.4				
I	33.5		40			46.5		72.5				
L	Hole for M4 screws		Hole for M5 screws			Hole for M5 screws			Hole for M6 screws			
M (relief)	1/8"		1/4"			3/8"		1"				
R (pilot)	1/8"		1/8"			1/8"		1/8"				
P	-		-			-		150				

DIMENSIONS OF V3V SOLENOID/SOLENOID PILOT-ASSISTED VALVE

100 SOLENOID/SOLENOID PILOT-ASSISTED VALVE

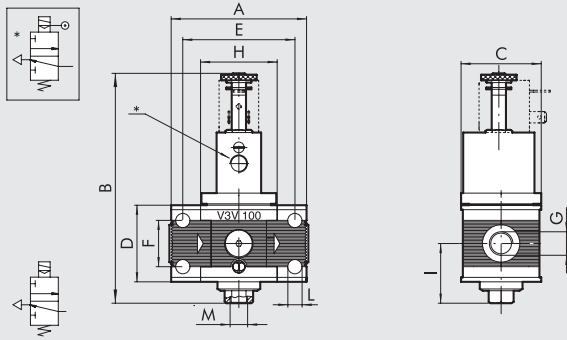

200 SOLENOID/SOLENOID PILOT-ASSISTED VALVE

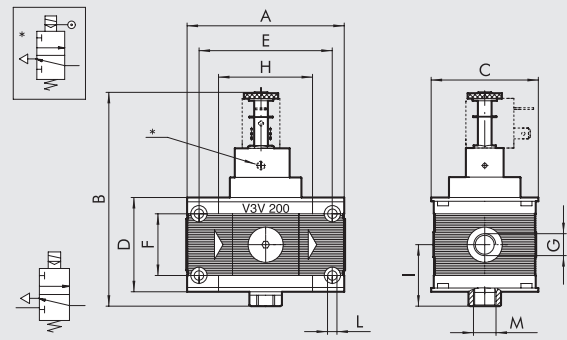

200 CNOMO

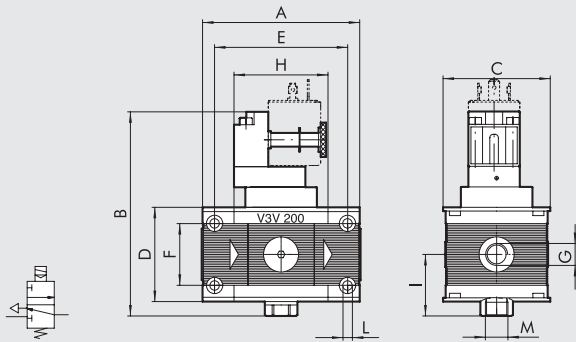

300 CNOMO SOLENOID/CNOMO SOLENOID PILOT-ASSISTED VALVE

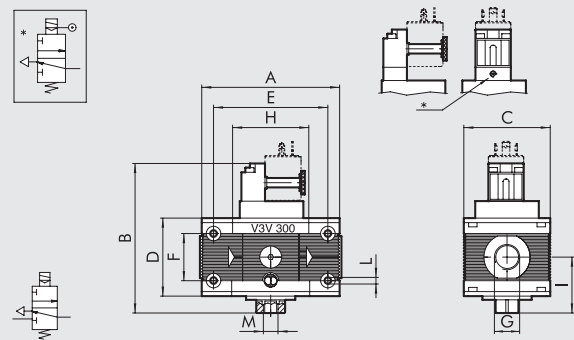

400 CNOMO SOLENOID/CNOMO SOLENOID PILOT-ASSISTED VALVE

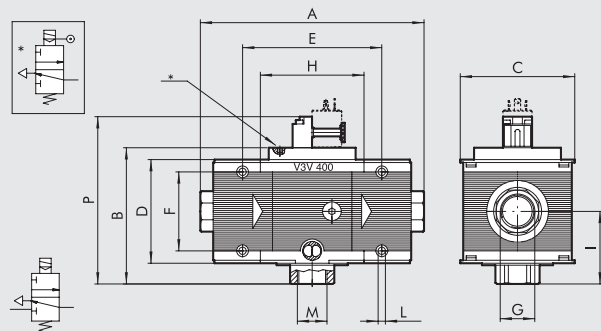

	V3V 100		V3V 200			V3V 300			V3V 400			
Threaded port G	1/4"	3/8"	1/4"	3/8"	1/2"	1/2"	3/4"	1"	1"	1 1/4"	1 1/2"	2"
A	78		93.5			110		112	225 to 255			283 to 313
B Solenoid	128		129			152			-			
Solenoid pilot-ass.	129		129			-			-			
CNOMO control	-		123			125			137			
CNOMO pilot-ass.	-		-			138			137			
C	50		63			72			118			
D	43		55			65			105			
E	63		78.5			92			141.4			
F	26		36			42			80			
H	43		55.5			65			105.4			
I	33.5		40			46.5			72.5			
L	Hole for M4 screws		Hole for M5 screws			Hole for M5 screws			Hole for M6 screws			
M (relief)	1/8"		1/4"			3/8"			1"			
* (pilot)	1/8"		M5			M5			M5			
P	-		-			-			169			

UNITS
Skilair® SHUT-OFF VALVE

SYNOPTIC, SIZES AND VERSIONS

V3V ELEMENT	100 SIZE	1/4 THREADED PORT	MANUAL TYPE OF COMMAND
V3V	100	1/4	Manual (lockable)
		3/8	
	200	1/4	Pneumatic
		3/8	
		1/2	
	300	1/2	Solenoid pilot assisted
		3/4	
		1	
	400	1	Solenoid
		1 1/4	
		1 1/2	
		2	

ORDERING CODES

Code	Description	Code	Description	Code	Description
Skillair® 100 3-WAY VALVE		Skillair® 300 3-WAY VALVE		Skillair® 400 3-WAY VALVE	
3270001A	V3V 100 lockable without end plates	4470001A	V3V 300 lockable without end plates	6169010A	V3V 400 key-operated without end plates
3269000A	V3V 100 pneumatic without end plates	4469000A	V3V 300 pneumatic without end plates	6169000A	V3V 400 pneumatic without end plates
3269001A	V3V 100 solenoid without end plates	4469004A	V3V 300 solenoid cnomo without end plates	6169004A	V3V 400 solenoid cnomo without end plates
3269002A	V3V 100 solenoid pilot assisted without end plates	4469005A	V3V 300 solenoid cnomo pilot-assisted w/end plates	6169005A	V3V 400 solenoid cnomo pilot-assisted w/end plates
3270001	V3V 100 1/4 lockable	4470001	V3V 300 1/2 lockable	6170002A	V3V 400 lockable without end plates
3269000	V3V 100 1/4 pneumatic	4469000	V3V 300 1/2 pneumatic	6169010	V3V 400 1 key-operated
3269001	V3V 100 1/4 solenoid	4469004	V3V 300 1/2 solenoid cnomo	6169000	V3V 400 1 pneumatic
3269002	V3V 100 1/4 solenoid pilot assisted	4469005	V3V 300 1/2 solenoid cnomo assisted	6169004	V3V 400 1 solenoid cnomo
3370001	V3V 100 3/8 lockable	4570001	V3V 300 3/4 lockable	6169005	V3V 400 1 solenoid cnomo assisted
3369000	V3V 100 3/8 pneumatic	4569000	V3V 300 3/4 pneumatic	6269010	V3V 400 1 1/4 key-operated
3369001	V3V 100 3/8 solenoid	4569004	V3V 300 3/4 solenoid cnomo	6269000	V3V 400 1 1/4 pneumatic
3369002	V3V 100 3/8 solenoid pilot assisted	4569005	V3V 300 3/4 solenoid cnomo assisted	6269004	V3V 400 1 1/4 solenoid cnomo
Skillair® 200 3-WAY VALVE		4669000	V3V 300 1 pneumatic	6269005	V3V 400 1 1/4 solenoid cnomo assisted
3470001A	V3V 200 lockable without end plates	4669004	V3V 300 1 solenoid cnomo	6369010	V3V 400 1 1/2 key-operated
3469000A	V3V 200 pneumatic without end plates	4669005	V3V 300 1 solenoid cnomo assisted	6369000	V3V 400 1 1/2 pneumatic
3469001A	V3V 200 solenoid without end plates	4670001	V3V 300 1 lockable	6369004	V3V 400 1 1/2 solenoid cnomo
3469002A	V3V 200 solenoid pilot assisted without end plates			6369005	V3V 400 1 1/2 solenoid cnomo assisted
3469004A	V3V 200 solenoid cnomo comm. w/end plate			6469010	V3V 400 2 key-operated
3469005A	V3V 200 solenoid cnomo ass. comm. w/end plate			6469000	V3V 400 2 pneumatic
3470001	V3V 200 1/4 lockable			6469004	V3V 400 2 solenoid cnomo
3469000	V3V 200 1/4 pneumatic			6469005	V3V 400 2 solenoid cnomo assisted
3469001	V3V 200 1/4 solenoid			6170002	V3V 400 1 lockable
3469002	V3V 200 1/4 solenoid pilot assisted			6270002	V3V 400 1 1/4 lockable
3469004	V3V 200 1/4 solenoid cnomo comm.			6370002	V3V 400 1 1/2 lockable
3469005	V3V 200 1/4 solenoid cnomo pilot-assisted			6470002	V3V 400 2 lockable
3570001	V3V 200 3/8 lockable				
3569000	V3V 200 3/8 pneumatic				
3569001	V3V 200 3/8 solenoid				
3569002	V3V 200 3/8 solenoid pilot assisted				
3569004	V3V 200 3/8 solenoid cnomo comm.				
3569005	V3V 200 3/8 solenoid cnomo pilot-assisted				
3670001	V3V 200 1/2 lockable				
3669000	V3V 200 1/2 pneumatic				
3669001	V3V 200 1/2 solenoid				
3669002	V3V 200 1/2 solenoid pilot assisted				
3669004	V3V 200 1/2 solenoid cnomo comm.				
3669005	V3V 200 1/2 solenoid cnomo pilot-assisted				

UNITS

Skillair® SHUT-OFF VALVE

Skillair® PROGRESSIVE START VALVE



The 2/2 progressive valve comes in two versions, with solenoid or pneumatic actuation.

STD progressive start valve: a differential balanced valve automatically opens the air port fully when the downstream pressure is about 50% of the upstream pressure.

Progressive start valve with pneumatic or solenoid actuation: without a pilot, the upstream air flows downstream through the regulation needle.

When an external or pneumatic solenoid signal is generated, the valve opens the main port to create full flow. It does not relieve the downstream circuit.



TECHNICAL DATA		VAP 100	
		1/4"	3/8"
Threaded port		1/4"	3/8"
Min. inlet pressure **	MPa	0.3	
	bar	3	
	psi	43.5	
Max. inlet pressure*	MPa	1.5	
	bar	15	
	psi	217	
Flow rate at 6 bar (0.6 MPa to 87 psi) ΔP 0.5 bar (0.05 MPa to 7 psi)	Nl/min	1300	
	scfm	46	
Flow rate at 6 bar (0.6 MPa to 87 psi) ΔP 1 bar (0.1 MPa to 14 psi)	Nl/min	2000	
	scfm	71	
Max temperature	°C	50	
	°F	122	
Weight	kg	0.5 ~	
Wall fixing screws		M4 x 50	
Mounting position		In any position	
Type of control		Automatic - Pneumatic - Solenoid - Solenoid pilot-assisted	
Fluid		Filtered, lubricated or unlubricated compressed air. Lubrication, if used, must be continuous	
** 0.01 MPa – 0.1 bar – 1.45 psi for pneumatic and pilot-assisted versions with controls at min. 0.3 MPa 3 bar 43.5 psi.			
* 1 MPa – 10 bar – 1.45 psi			

UNITS
Skillair® PROGRESSIVE START VALVE

Skillair® PROGRESSIVE STARTER



The job of the progressive starter is to feed air into the circuit gradually with controlled flow. It comes in two versions with solenoid or pneumatic actuation. Both control signals cause the valve to open, which allows the air controlled by the flow regulator to flow slowly towards the downstream circuit. In the APR, when the pressure in the downstream circuit reaches 50%-60% of the upstream pressure, the valve opens the main inlet duct connecting. The time elapsing between starting and opening the valve can be adjusted via the built-in flow regulator. If it is necessary to relieve the downstream circuit quickly, merely operate the control valve which cuts off air flow in the pipe. This closes the valve and starts relieving the downstream circuit. The progressive starter acts both as an actuator positioner, which eliminates the risk of sudden kickback, and as a valve.

N.B. With size 400, when the APR is mounted upstream of the regulator, the pilot regulator must be piloted at a pressure taken upstream of the APR, otherwise when the system is relieved, most of the air downstream will be relieved by the regulator and not the APR relief port. For connecting instruction see page C3.23

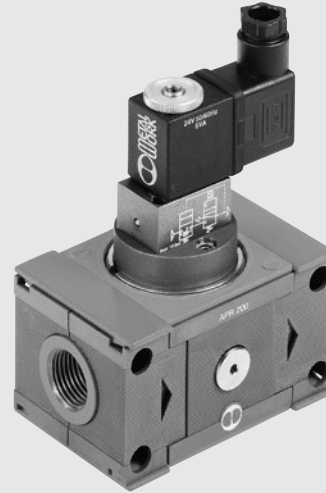

TECHNICAL DATA	APR 100		APR 200			APR 300			APR 400			
	1/4"	3/8"	1/4"	3/8"	1/2"	1/2"	3/4"	1"	1"	1 1/4"	1 1/2"	2"
Threaded port												
Min. inlet pressure	MPa	0.3		0.3			0.4			0.3		0.3
	bar	3		3			4			3		3
	psi	43.5		43.5			58			43.5		43.5
Max. inlet pressure*	MPa	1.5		1.3			1.3			1		1
	bar	15		13			13			10		10
	psi	217		188.5			188.5			145		145
Flow rate at 6.3 bar (0.63 MPa to 91 psi)	Nl/min	1300		2000			2400			13000		14000
ΔP 0.5 bar (0.05 MPa to 7 psi)	scfm	46		71			85			460		494
Flow rate at 6.3 bar (0.63 MPa to 91 psi)	Nl/min	2000		3200			3600			-		-
ΔP 1 bar (0.1 MPa to 14 psi)	scfm	71		113			127			-		-
Max temperature	°C	50		50			50			50		50
	°F	122		122			122			122		122
Weight	kg	~ 0.8		~ 0.9			~ 1.5			5.6		6.4
Wall fixing screws		M4 x 50		M5 x 60			M5 x 70			M6 x 110		M6 x 110
Type of control		Pneumatic		Pneumatic			Pneumatic			Pneumatic - Solenoid		
		Solenoid		Solenoid			CNOMO Solenoid					
Mounting position		In any position										
Fluid		Filtered, lubricated or unlubricated compressed air. Lubrication, if used, must be continuous.										
Notes on use		For the pneumatic version 200 the pilot pressure must range between the inlet P and the inlet P + 2 bar.										
		For pneumatic version 300, the pilot pressure must be greater or equal to the input pressure. * 1 MPa - 10 bar - 145 psi for solenoid version										

DIMENSIONS APR SOLENOID

APR 100 SOLENOID

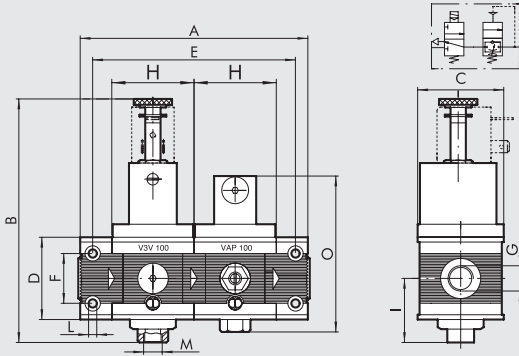

APR 200 SOLENOID

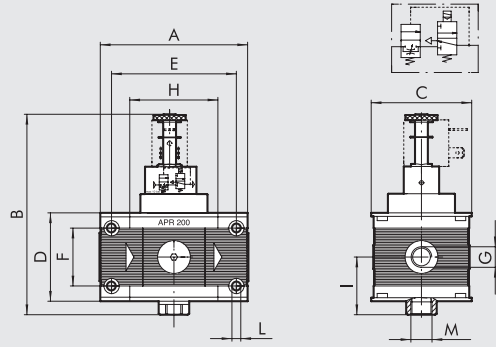

APR 200 CNOMO SOLENOID

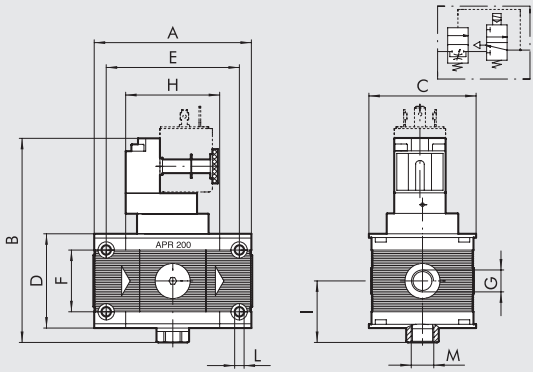

APR 300 CNOMO SOLENOID

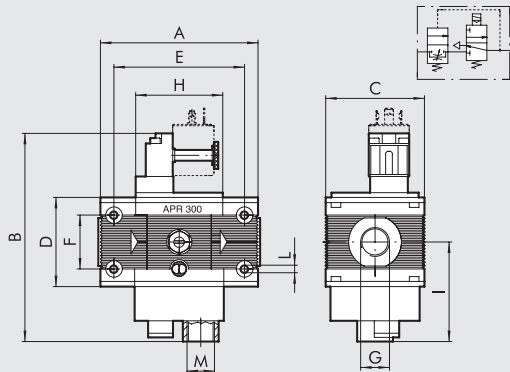

APR 400 SOLENOID

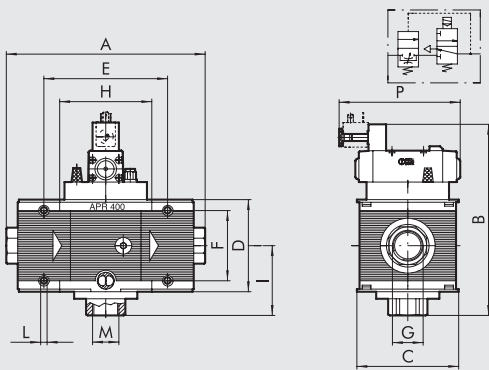

UNITS

Skilair® PROGRESSIVE STARTER

	APR 100 ELPN		APR 200 ELPN			APR 200 ELPN CNOMO			APR 300 ELPN CNOMO			APR 400 ELPN			
Threaded port G	1/4"	3/8"	1/4"	3/8"	1/2"	1/4"	3/8"	1/2"	1/2"	3/4"	1"	1"	1 1/4"	1 1/2"	2"
A	121		93.5			93.5			110	112		225 to 255			283 to 313
B	128		125			120			152			218			
C	50		63			63			72			118			
D	43		55			55			65			105			
E	106		78.5			78.5			92			141.4			
F	26		36			36			42			80			
H	43		55.5			55.5			65			105.4			
I	34.5		36			36			74			80			
L	Hole for M4 screws		Hole for M5 screws			Hole for M5 screws			Hole for M5 screws			Hole for M6 screws			
M (relief)	1/8"		1/4"			1/4"			1/2"			1"			
O	83.5		-			-			-			-			
P	-		-			-			-			138			

DIMENSIONS APR PNEUMATIC

APR 100 PNEUMATIC

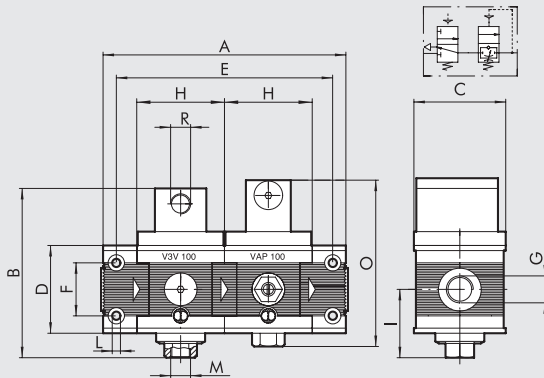

APR 200 PNEUMATIC

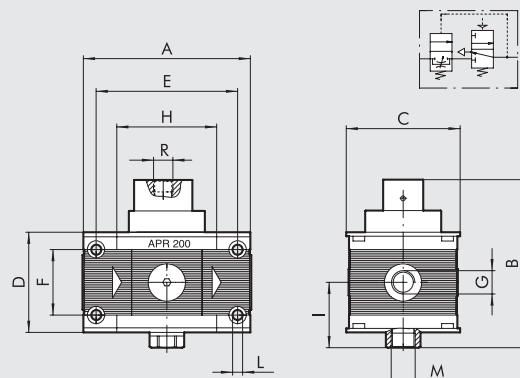

APR 300 PNEUMATIC

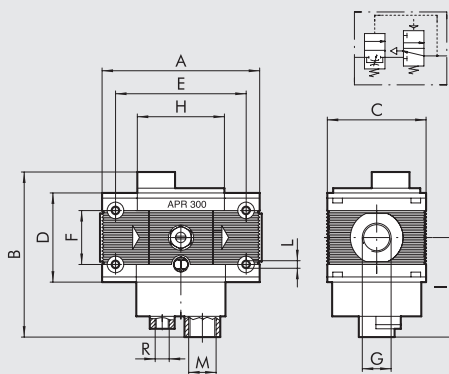

APR 400 PNEUMATIC

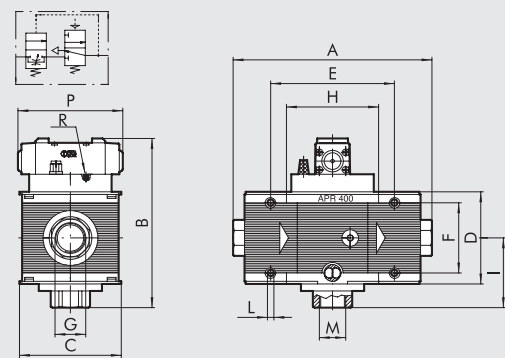

Threaded port G	APR 100 PN		APR 200 PN			APR 300 PN			APR 400 PN			
	1/4"	3/8"	1/4"	3/8"	1/2"	1/2"	3/4"	1"	1"	1 1/4"	1 1/2"	2"
A	121			93.5		110		112		225 to 255		283 to 313
B	83			92			122			193		
C	50			63			72			118		
D	43			55			65			105		
E	106			78.5			92			141.4		
F	26			36			42			80		
H	43			55.5			65			105.4		
I	34.5			36			74			80		
L	Hole for M4 screws		Hole for M5 screws			Hole for M5 screws			Hole for M6 screws			
M (relief)	1/8"			1/4"			1/2"			1"		
R (pilot)	1/8"			1/8"			1/4"			M5		
P	-			-			-			119		

SYNOPTIC, SIZES AND VERSIONS

APR ELEMENT	100 SIZE	1/4 THREADED PORT	PNEUMATIC TYPE OF CONTROL
APR	100	1/4	Pneumatic Solenoid
		3/8	
	200	1/4	
		3/8	
		1/2	
	300	1/2	
		3/4	
	400	1	
		1	
		1 1/4	
		1 1/2	
		2	
		2	

ORDERING CODES

Code	Description	Code	Description
Skillair® 100 PROGRESSIVE STARTER		Skillair® 300 PROGRESSIVE STARTER	
3267001A	APR 100 pneumatic without end plates	4471900A	APR 300 pneumatic without end plates
3267051A	APR 100 solenoid without end plates	4471901A	APR 300 solenoid cno mo without end plates
3267001	APR 100 1/4 pneumatic	4471900	APR 300 1/2 pneumatic
3267051	APR 100 1/4 solenoid	4471901	APR 300 1/2 solenoid cno mo control
3367001	APR 100 3/8 pneumatic	4571900	APR 300 3/4 pneumatic
3367051	APR 100 3/8 solenoid	4571901	APR 300 3/4 solenoid cno mo control
Skillair® 200 PROGRESSIVE STARTER		Skillair® 400 PROGRESSIVE STARTER	
3471000A	APR 200 pneumatic without end plates	4671900	APR 300 1 pneumatic
3471001A	APR 200 solenoid without end plates	4671901	APR 300 1 solenoid cno mo control
3471004A	APR 200 solenoid cno mo without end plates	Skillair® 400 PROGRESSIVE STARTER	
3471000	APR 200 1/4 pneumatic	6171002A	APR 400 pneumatic without end plates
3471001	APR 200 1/4 solenoid	6171003A	APR 400 solenoid without end plates
3471004	APR 200 1/4 solenoid cno mo control	6171002	APR 400 1 pneumatic
3571000	APR 200 3/8 pneumatic	6171003	APR 400 1 solenoid
3571001	APR 200 3/8 solenoid	6271002	APR 400 1 1/4 pneumatic
3571004	APR 200 3/8 solenoid cno mo control	6271003	APR 400 1 1/4 solenoid
3671000	APR 200 1/2 pneumatic	6371002	APR 400 1 1/2 pneumatic
3671001	APR 200 1/2 solenoid	6371003	APR 400 1 1/2 solenoid
3671004	APR 200 1/2 solenoid cno mo control	6471002	APR 400 2 pneumatic
		6471003	APR 400 2 solenoid

UNITS

AVIATORE PROGRESSIVO Skillair®

Skillair® AIR TAKE-OFF



The air take-off takes air from the Skillair® FRL unit irrespective of the assembly position. It is necessary when air needs to be taken from the FRL unit at any stage of the treatment (normal, filtered and regulated, lubricated, etc.). If used separately from the FRL unit, which is infinitely modular, it acts as a distributor allowing air take-off through the threaded ports.

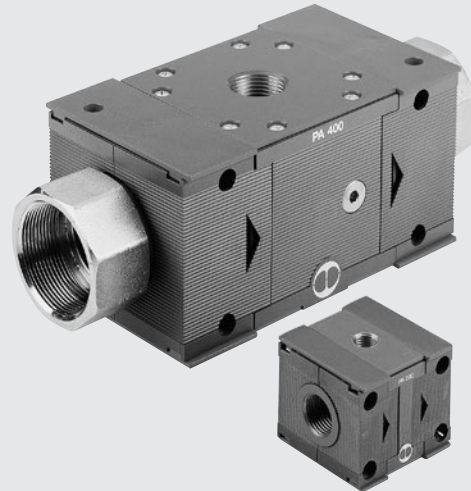

TECHNICAL DATA	PA 100		PA 200			PA 300			PA 400			
Threaded port	1/4"	3/8"	1/4"	3/8"	1/2"	1/2"	3/4"	1"	1"	1 1/4"	1 1/2"	2"
Max. working temperature	°C 50		°C 50			°C 50			°C 50			
at: 1 MPa; 10 bar; 145 psi	°F 122		°F 122			°F 122			°F 122			
Max. operating pressure	MPa 1.5		MPa 1.3			MPa 1.3			MPa 1.3			
	bar 15		bar 13			bar 13			bar 13			
	psi 217		psi 188			psi 188			psi 188			
Wall fixing screws	M4 x 50		M5 x 60			M5 x 70			M6 x 110			
Threaded port	G 1/4		G 1/4			G 3/8			G 1			
Weight	kg 0.3		kg 0.5			kg 0.8			kg 4.3		kg 5.1	

DIMENSIONS AND ORDERING CODES

100 - 200 - 300

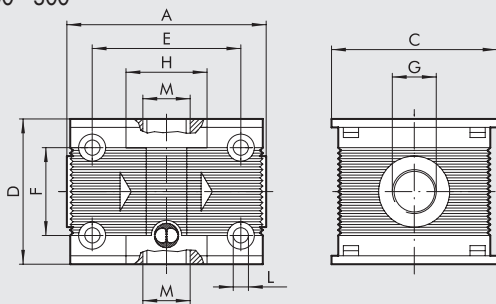

400

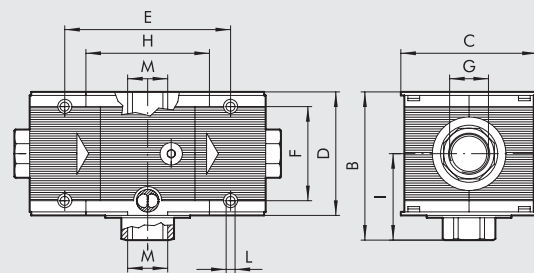

	PA 100		PA 200			PA 300			PA 400				Code	Description		
Threaded port G	1/4"	3/8"	1/4"	3/8"	1/2"	1/2"	3/4"	1"	1"	1 1/4"	1 1/2"	2"	9200402A	PA 100 without end plates		
A	59		63			117			119				225 to 255	283 to 313	9200402	PA 100 1/4
B	-		-			-			-				120		9300401	PA 100 3/8
C	50		63			72			118						9300402A	PA 200 without end plates
D	43		55			65			105						9300404	PA 200 1/2
E	44		48			59			141.4						9300402	PA 200 1/4
F	26		36			42			80						9300403	PA 200 3/8
H	24		25			32			105.4						9400402A	PA 300 without end plates
I	-		-			-			67.5						9500402	PA 300 1
L	Hole for M4 screws		Hole for M5 screws			Hole for M5 screws			Hole for M6 screws						9400402	PA 300 1/2
M	1/4"		1/4"			3/8"			1"						9500401	PA 300 3/4
															9700401A	PA 400 without end plates
															9700401	PA 400 1
															9700403	PA 400 1 1/2
															9700402	PA 400 1 1/4
															9700404	PA 400 2

UNITS

Skillair® AIR TAKE-OFF

Skillair® PRESSURE SWITCHES

Skillair® pressure switches feature a high degree of miniaturisation and a modern attractive design. As they are extremely modular, the Skillair® series can be installed facing up or down.

They come ready assembled with a 2-metre cable or an M8 connector with a 300-mm cable.

The contact is the switching type, which means it can be normally open or normally closed. It can be regulated via a knurled push-lock handle. On the side opposite the regulation handle is a threaded air inlet port that can be used by removing the threaded plug.

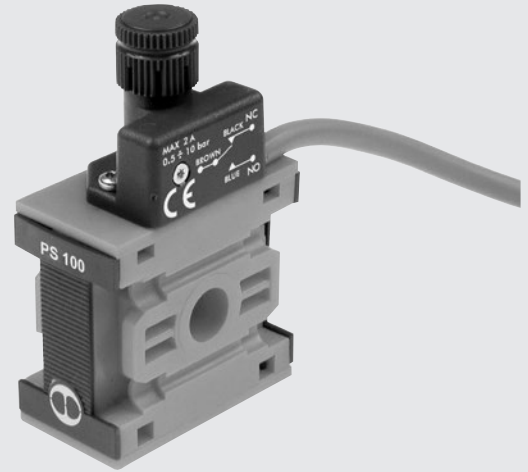

TECHNICAL DATA		PS 100	PS 200	PS 300
Adjustable pressure interval	bar		0.5 to 10	
Hysteresis (not adjustable)	bar		from 0.4 to 0.8 (See diagram)	
Maximum pressure	bar	15	13	13
	MPa	1.5	1.3	1.3
Operating temperature range at: 1 MPa; 10 bar; 145 psi	psi	217	188	188
	°C		-10 to 50	
	°F		14 to 122	
Lower threaded port		1/4"	1/4"	3/8"
Maximum current	A		2	
Maximum voltage	V		250	
Outside diameter of cable	mm		4.9	
Number of wires and cross section			3 x 0.5 mm ²	
Contacts			Normally-Open (NO) and Normally-Closed (NC)	
Protection			IP65	
Number of switchings			5 x 10 ⁶	
Fluid			Filtered lubricated or unlubricated compressed air. Lubrication, if used, must be continuous.	
Mounting position			In any position.	
Weight	kg	0.160	0.185	0.250

COMPONENTS

- ① Technopolymer adjusting push-lock handle
- ② Brass adjusting screw
- ③ Steel piston spring
- ④ Brass piston
- ⑤ NBR gasket
- ⑥ Choke to reduce peaks in pressure
- ⑦ Technopolymer pressure switch body
- ⑧ Resin finish for IP65
- ⑨ Electrical contact
- ⑩ Technopolymer body
- ⑪ Supplementary air inlet port
- ⑫ A7 plug

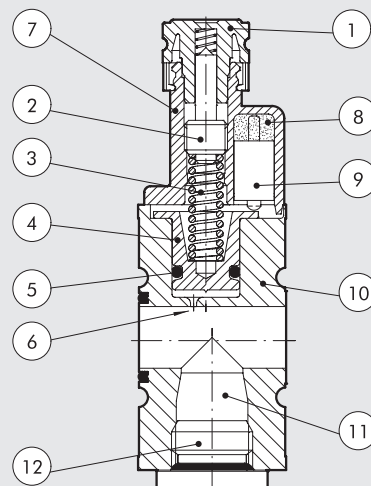

DIMENSIONS

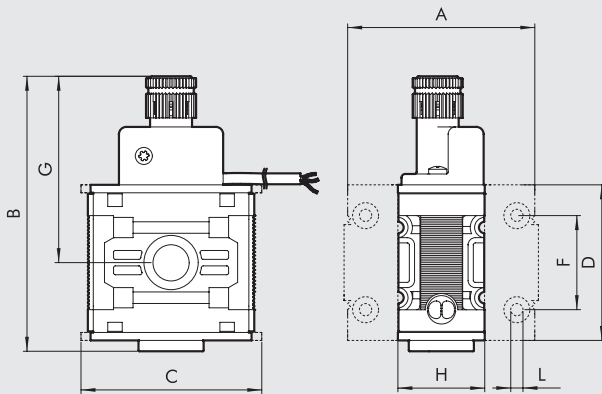

	PS 100	PS 200	PS 300
A	59	63	177
B	76	85	99
C	50	63	72
D	43	55	65
F	26	36	42
G	52	58	63
H	24	25	32
L	Hole for M4 screws	Hole for M5 screws	Hole for M5 screws

WIRING DIAGRAM

VERSION WITH CABLE

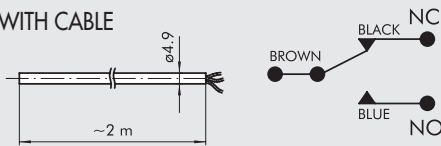

VERSION WITH M8 CONNECTOR

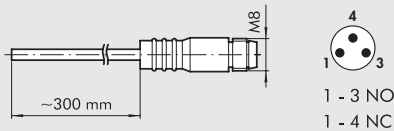

HYSTERESIS GRAPH

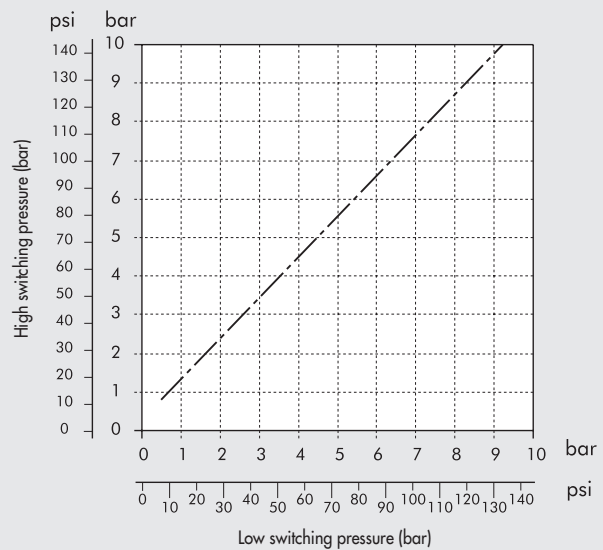

ORDERING CODES

Code	Description
Skillair® 100 PRESSURE SWITCHES	
3240000A	PS 100 2A NO/NC 2 m cable without end plates
3240001A	PS 100 2A NO/NC M8 connector without end plates
Skillair® 200 PRESSURE SWITCHES	
3440000A	PS 200 2A NO/NC 2 m cable without end plates
3440001A	PS 200 2A NO/NC M8 connector without end plates
Skillair® 300 PRESSURE SWITCHES	
4440000A	PS 300 2A NO/NC 2 m cable without end plates
4440001A	PS 300 2A NO/NC M8 connector without end plates

ACCESSORIES

SECURITY KNOB

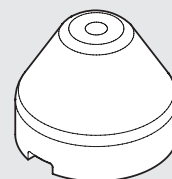

Code	Description
9200703	Security knob APR / pressure switch

NOTE: Pull outwards to remove the knob from the pressure switch on the unit. Insert the security knob and regulate the pressure switch. Then press the handle firmly to lock it in position. If the pressure switch needs to be reset, remove the security knob by forcing it laterally with a screwdriver.

Skillair® SUB-BASE AND ADAPTER BASE

The adapter base is used to adapt the Skillair® FRL system to various assemblies without affecting modularity or servicing. If you use the universal adapter base plus the intermediate plate, you can assemble several elements of different sizes.



DIMENSIONS

2-POSITION SUB-BASE

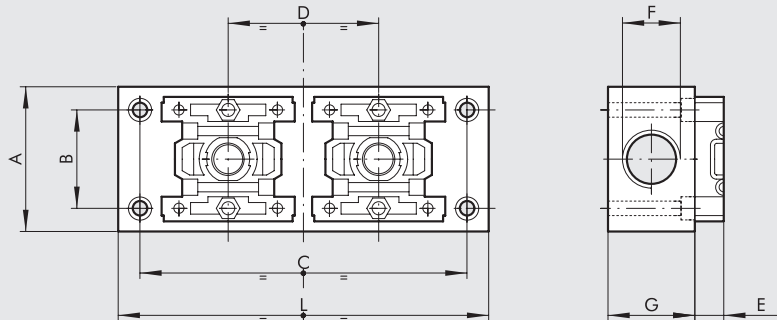

3-POSITION SUB-BASE

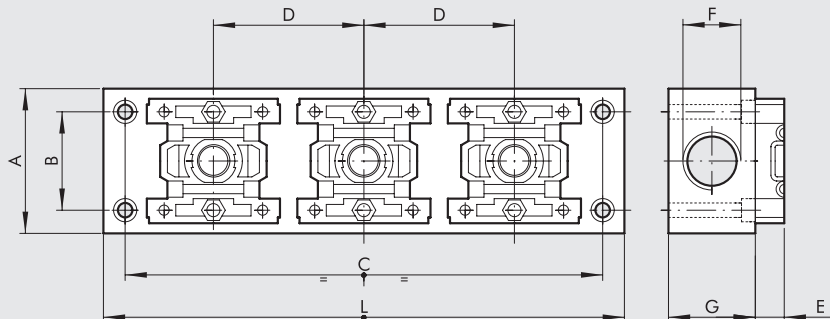

	100 - 2 POS.	100 - 3 POS.	200 - 2 POS.	200 - 3 POS.	300 - 2 POS.	300 - 3 POS.
A	50	50	55	55	60	60
B	34	34	44	44	49	49
C	113	165	135	200	155	230
D	52	52	65	65	75	75
E	10	10	8.5	8.5	10.5	10.5
F	1/2"	1/2"	3/4"	3/4"	3/4"	3/4"
G	30	30	40	40	40	40
L	128	180	150	215	170	245

DIMENSIONS OF ADAPTER BASE

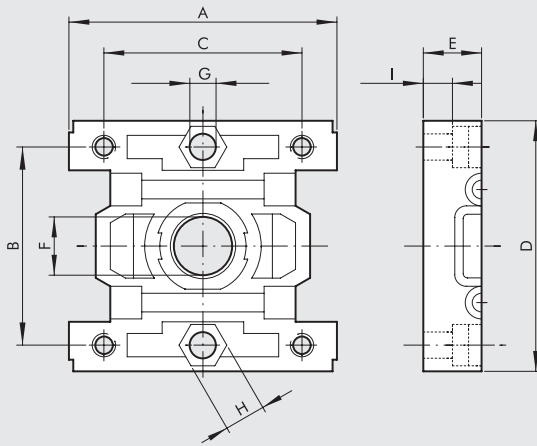

	BA 100	BA 200	BA 300
A	46	59	69
B	34	44	49
C	34	44	49
D	43	55	65
E	10	8.5	10.5
F	10	15	18
G	Hole for M4 screws	Hole for M4 screws	Hole for M5 screws
H	Es. 7	Es. 7	Es. 7
I	5	2	5

DIMENSIONS OF SIZE ADAPTERS

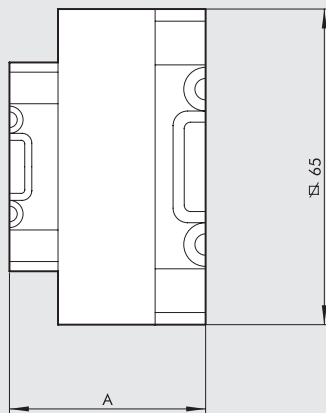

	BA 100 - 200	BA 100 - 300	BA 200 - 300
A	38.5	40.5	39

ORDERING CODES

Code	Description
MULTIPLE SUB-BASES FOR REGULATORS	
9200202	SB 2 100
9300202	SB 2 200
9400202	SB 2 300
9200302	SB 3 100
9300302	SB 3 200
9400302	SB 3 300
ADAPTER BASE	
9201801	BA 100
9321801	BA 200
9401801	BA 300
SIZE ADAPTER	
9301801	BA 100 - 200
9301802	BA 100 - 300
9301803	BA 200 - 300

NOTES

FIL + REG + LUB Skillair®

Refer to the sections on the single modules for a further description, components and other technical data.



TECHNICAL DATA	FRL 100		FRL 200			FRL 300			FRL 400			
Threaded port	1/4"	3/8"	1/4"	3/8"	1/2"	1/2"	3/4"	1"	1"	1 1/4"	1 1/2"	2"
Setting range	0 to 8 - 0 to 12		0 to 8 - 0 to 12			0 to 8 - 0 to 12			Depending on pilot regulator			
Degree of filtration	µm		5 - 20		5 - 20		5 - 20		5 - 20 - 50			5 - 20 - 50
Max. inlet pressure	MPa		1.5		1.3		1.3		1.3			1.3
	bar		15		13		13		13			13
Flow rate at 6.3 bar ΔP 0.5 bar	psi		217		188		188		188			188
	NI/min		300		1300		2500		9000			14000
Flow rate at 6.3 bar ΔP 1 bar	scfm		11		46		89		320			500
	NI/min		800		3000		4500		-			-
Max temperature at 10 bar	scfm		28		106		160		-			-
	°C		50		50		50		50			50
Weight	°F		122		122		122		122			122
	kg		0.75		1.5		2.9		~ 10			~ 10
Wall fixing screws	M4 x 50		M5 x 60			M5 x 70			M6 x 110		M6 x 110	
Fluid	Compressed air											
Notes on use	The maximum inlet pressure for the version with RA automatic condensate drainage must not exceed 10 bar. Do not take air from pressure gauge ports.											

SYNOPTIC, SIZES AND VERSIONS

FRL ELEMENT	100 SIZE	1/4 THREADED PORT	20 DEGREE OF FILTRATION	08 SETTING RANGE	RMSA TYPE OF CONDENSATION DRAIN
FRL	100	1/4	5 = 5 µm	08 = 0 to 8 bar	RMSA
	200	3/8	20 = 20 µm	012 = 0 to 12 bar	SAC
		1/4	50 = 50 µm		RMSA
		3/8			SAC
	300	1/2			RA
		3/4			RMSA
		1			RA
	400	1			
		1 1/4			
		1 1/2			
		2			

RMSA: drain with manual condensate discharge and automatic discharge at zero pressure

RA: automatic drain with condensate discharge, independent of pressure and flow rate.
(for size 200, 300 and 400).
Version conveys the draining by inserting the pipe having internal diameter 6 mm in the lower port.

SAC: automatic drain with condensate discharge.
Operates by pressure drop – requires variable air take-offs.
(for size 100 and 200)

DIMENSIONS FIL + REG + LUB

100 - 200 - 300

400

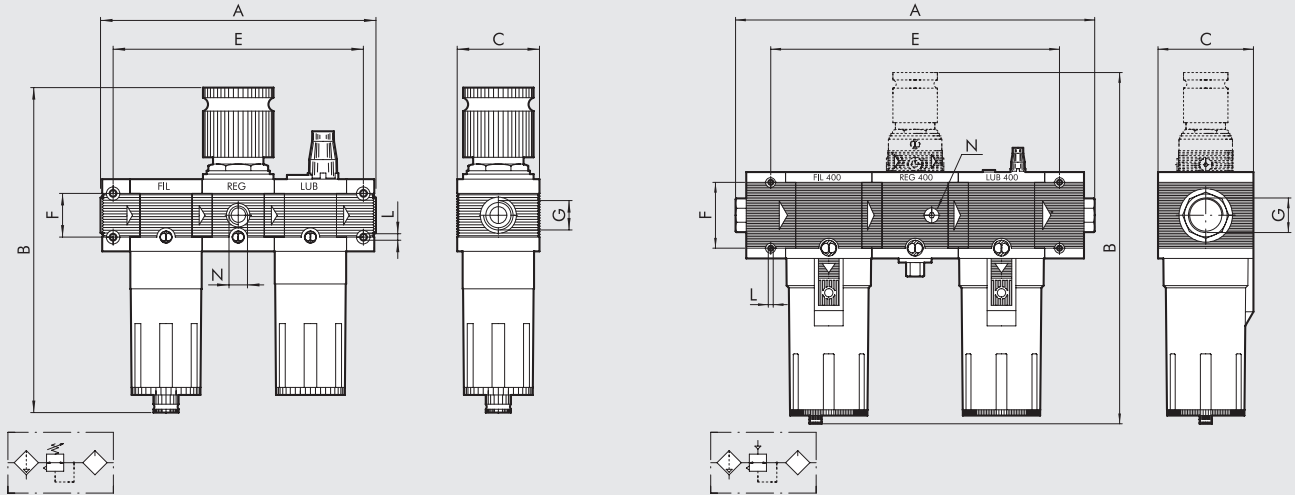

	FIL + REG + LUB 100		FIL + REG + LUB 200			FIL + REG + LUB 300			FIL + REG + LUB 400			
Threaded port G	1/4"	3/8"	1/4"	3/8"	1/2"	1/2"	3/4"	1"	1"	1 1/4"	1 1/2"	2"
A	164		204.5			240			436 to 466			
B	RMSA	199	245			278			444			
	RA	-	249			282			448			
	SAC	203	249			282			448			
C	50		63			72			118			
E	149		189.5			222			352			
F	26		36			42			80			
L	Hole for M4 screws		Hole for M5 screws			Hole for M5 screws			Hole for M6 screws			
N (pressure gauge port)	1/8"		1/8"			1/8"			1/4"			

ORDERING CODES

Code Description

FIL+REG+LUB Skillair® 100

- 3282008 FRL 100 1/4 20 08 RMSA
- 3282011 FRL 100 1/4 20 012 RMSA
- 3382008 FRL 100 3/8 20 08 RMSA
- 3382011 FRL 100 3/8 20 012 RMSA

FIL+REG+LUB Skillair® 200

- 3482008 FRL 200 1/4 20 08 RMSA
- 3482011 FRL 200 1/4 20 012 RMSA
- 3582008 FRL 200 3/8 20 08 RMSA
- 3582011 FRL 200 3/8 20 012 RMSA
- 3682008 FRL 200 1/2 20 08 RMSA
- 3682011 FRL 200 1/2 20 012 RMSA

FIL+REG+LUB Skillair® 300

- 4482005 FRL 300 1/2 20 08 RMSA
- 4482008 FRL 300 1/2 20 012 RMSA
- 4582005 FRL 300 3/4 20 08 RMSA
- 4582008 FRL 300 3/4 20 012 RMSA
- 4682005 FRL 300 1 20 08 RMSA
- 4682008 FRL 300 1 20 012 RMSA

FIL+REG+LUB Skillair® 400

- 6182002 FRL 400 1 20 RMSA
- 6182005 FRL 400 1 20 RA
- 6282002 FRL 400 1 1/4 20 RMSA
- 6382002 FRL 400 1 1/2 20 RMSA
- 6482002 FRL 400 2 20 RMSA

The following versions are available on request:

- with 5 µm or 50 µm degree of filtration
- with SAC or RA condensate discharge

FR + LUB Skillair®

Refer to the sections on the single modules for a further description, components and other technical data.



UNITS

FR + LUB Skillair®

TECHNICAL DATA	FR + LUB 100		FR + LUB 200			FR + LUB 300		
	Threaded port	1/4"	3/8"	1/4"	3/8"	1/2"	1/2"	3/4"
Setting range	0 to 8 - 0 to 12		0 to 8 - 0 to 12			0 to 8 - 0 to 12		
Degree of filtration	µm	5 - 20 - 50	5 - 20 - 50			5 - 20 - 50		
Max. inlet pressure	MPa	1.5	1.3			1.3		
	bar	15	13			13		
	psi	217	188			188		
Flow rate at 6.3 bar ΔP 0.5 bar	NI/min	300	1200			2300		
	scfm	11	43			82		
Flow rate at 6.3 bar ΔP 1 bar	NI/min	800	2400			4000		
	scfm	28	85			142		
Max temperature at 10 bar	°C	50	50			50		
	°F	122	122			122		
Weight	kg	0.7	1.35			2.7		
Wall fixing screws		M4 x 50	M4 x 60			M5 x 70		
Fluid		Compressed air						
Notes on use		The maximum inlet pressure for the version with RA automatic condensate drainage must not exceed 10 bar. Do not take air from pressure gauge ports.						

SYNOPTIC, SIZES AND VERSIONS

FR+L	100	1/4	20	08	RMSA	
ELEMENT	SIZE	THREADED PORT	DEGREE OF FILTRATION	SETTING RANGE	TYPE OF CONDENSATION RANGE	
FR+L	100	1/4	5 = 5 µm 20 = 20 µm 50 = 50 µm	08 = 0 to 8 bar 012 = 0 to 12 bar	RMSA	RMSA: drain with manual condensate discharge and automatic discharge at zero pressure RA: automatic drain with condensate discharge, independent of pressure and flow rate. (for size 200, 300). Version conveys the draining by inserting the pipe having internal diameter 6 mm in the lower port. SAC: automatic drain with condensate discharge. Operates by pressure drop – requires variable air take-offs. (for size 100 and 200)
	200	3/8			RMSA	
		1/4			SAC	
300	3/8	RA				
	1/2	RMSA				
	1/2	RA				

V3V + FR + LUB Skillair®

Refer to the sections on the single modules for a further description, components and other technical data.



TECHNICAL DATA	V + FR + L 100		V + FR + L 200			V + FR + L 300		
	Threaded port	1/4"	3/8"	1/4"	3/8"	1/2"	1/2"	3/4"
Setting range	0 to 8 - 0 to 12		0 to 8 - 0 to 12			0 to 8 - 0 to 12		
Degree of filtration	µm		µm			µm		
Max. inlet pressure	MPa		MPa			MPa		
	bar		bar			bar		
	psi		psi			psi		
Flow rate at 6.3 bar ΔP 0.5 bar	NI/min		NI/min			NI/min		
	scfm		scfm			scfm		
Flow rate at 6.3 bar ΔP 1 bar	NI/min		NI/min			NI/min		
	scfm		scfm			scfm		
Max temperature at 10 bar	°C		°C			°C		
	°F		°F			°F		
Weight	kg		kg			kg		
Wall fixing screws	M4 x 50		M5 x 60			M5 x 70		
Fluid	Compressed air.							
Notes on use	The maximum inlet pressure for the version with RA automatic condensate drainage must not exceed 10 bar. Do not take air from pressure gauge ports.							

SYNOPTIC, SIZES AND VERSIONS

VFR+L	100	1/4	20	08	RMSA
ELEMENT	SIZE	THREADED PORT	DEGREE OF FILTRATION	SETTING RANGE	TYPE OF CONDENSATE DRAIN
VFR+L	100	1/4 3/8	5 = 5 µm 20 = 20 µm 50 = 50 µm	08 = 0 to 8 bar 012 = 0 to 12 bar	RMSA
	200	1/4 3/8			SAC
		1/2			RMSA
300	1/2 3/4	1	RA		
			RMSA		
				RA	

RMSA: drain with manual condensate discharge and automatic discharge at zero pressure

RA: automatic drain with condensate discharge, independent of pressure and flow rate.
(for size 200, 300).
Version conveys the draining by inserting the pipe having internal diameter 6 mm in the lower port.

SAC: automatic drain with condensate discharge.
Operates by pressure drop – requires variable air take-offs.
(for size 100 and 200)

FIL + LUB Skillair®

Refer to the sections on the single modules for a further description, components and other technical data.



UNITS

FIL + LUB Skillair®

TECHNICAL DATA	F + L 100		F + L 200			F + L 300			F + L 400			
	1/4"	3/8"	1/4"	3/8"	1/2"	1/2"	3/4"	1"	1"	1 1/4"	1 1/2"	2"
Threaded port												
Degree of filtration	µm 5 - 20 - 50		5 - 20 - 50			5 - 20 - 50			5 - 20 - 50			
Max. inlet pressure	MPa 1.5		1.3			1.3			1.3			
	bar 15		13			13			13			
Flow rate at 6.3 bar ΔP 0.5 bar	psi 217		188			188			188			
	Nl/min 600		1800			3200			9000		14000	
Flow rate at 6.3 bar ΔP 1 bar	scfm 21		64			113			320		500	
	Nl/min 1200		3200			4500			-		-	
Max temperature at 10 bar	scfm 42		113			160			-		-	
	°C 50		50			50			50			
Weight	°F 122		122			122			122			
	kg 0.5		1.1			2.2			~ 8			
Wall fixing screws	M4 x 50		M5 x 60			M5 x 70			M6 x 110			
Fluid	Compressed air.											
Notes on use	The maximum inlet pressure for the version with RA automatic condensate drainage must not exceed 10 bar.											

SYNOPTIC, SIZES AND VERSIONS

F+L ELEMENT	100 SIZE	1/4 THREADED PORT	20 DEGREE OF FILTRATION	RMSA TYPE OF CONDENSATE DRAIN
F+L	100	1/4 3/8	5 = 5 µm 20 = 20 µm 50 = 50 µm	RMSA SAC RMSA RA
	200	1/4 3/8 1/2		
	300	1/2 3/4 1		
	400	1 1 1/4 1 1/2 2		

RMSA: drain with manual condensate discharge and automatic discharge at zero pressure

RA: automatic drain with condensate discharge, independent of pressure and flow rate. (for size 200, 300 and 400). Version conveys the draining by inserting the pipe having internal diameter 6 mm in the lower port.

SAC: automatic drain with condensate discharge.

Operates by pressure drop – requires variable air take-offs. (for size 100 and 200)

DIMENSIONS FIL + LUB

100 - 200 - 300

400

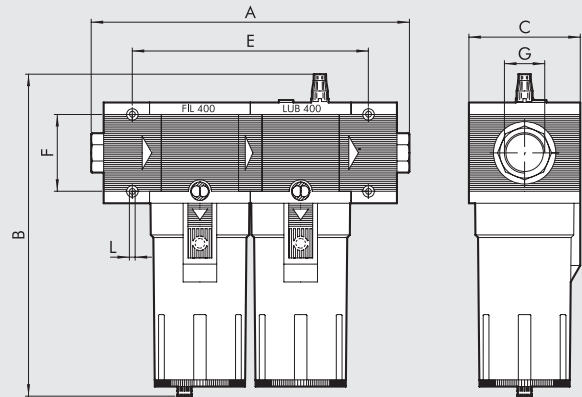
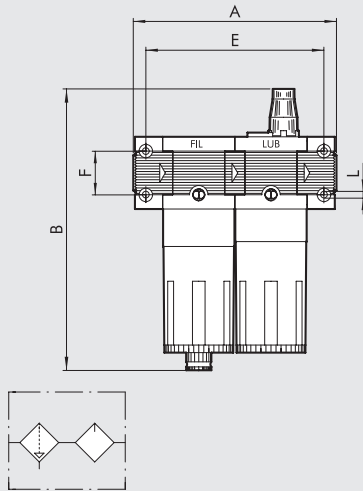

	FIL + LUB 100		FIL + LUB 200			FIL + LUB 300			FIL + LUB 400			
Threaded port G	1/4"	3/8"	1/4"	3/8"	1/2"	1/2"	3/4"	1"	1"	1 1/4"	1 1/2"	2"
A	121		149			175		177	330 to 360			
B	RMSA	172.5	203.5			223.5			349.5			
	RA	-	207.5			227.5			353.5			
	SAC	176.5	207.5			227.5			353.5			
C	50		63			72			118			
E	106		134			157			247			
F	26		36			42			80			
L	Hole for M4 screws		Hole for M5 screws			Hole for M5 screws			Hole for M6 screws			

ORDERING CODES

Code Description

F+L Skillair® 100

- 3285002 F+L 100 1/4 20 RMSA
- 3385002 F+L 100 3/8 20 RMSA

F+L Skillair® 200

- 3485002 F+L 200 1/4 20 RMSA
- 3585002 F+L 200 3/8 20 RMSA
- 3685002 F+L 200 1/2 20 RMSA

F+L Skillair® 300

- 4485002 F+L 300 1/2 20 RMSA
- 4585002 F+L 300 3/4 20 RMSA
- 4585005 F+L 300 3/4 20 RA
- 4685002 F+L 300 1 20 RMSA

F+L Skillair® 400

- 6185002 F+L 400 1 20 RMSA
- 6185005 F+L 400 1 20 RA
- 6285002 F+L 400 1 1/4 20 RMSA
- 6385002 F+L 400 1 1/2 20 RMSA
- 6485002 F+L 400 2 20 RMSA

The following versions are available on request:

- with 5 µm or 50 µm degree of filtration
- with SAC or RA condensate discharge

FIL + DEP Skillair®

Refer to the sections on the single modules for a further description, components and other technical data.



UNITS

FIL + DEP Skillair®

TECHNICAL DATA			F + D 100		F + D 200			F + D 300			F + D 400			
Threaded port			1/4"	3/8"	1/4"	3/8"	1/2"	1/2"	3/4"	1"	1"	1 1/4"	1 1/2"	2"
Degree of filtration	Filter	µm	5		5			5			5			
	Depurator	µm	0.01		0.01			0.01			0.01			
Max. inlet pressure		MPa	1.5		1.3			1.3			1.3			
		bar	15		13			13			13			
Max temperature at 10 bar		psi	217		188			188			188			
		°C	50		50			50			50			
		°F	122		122			122			122			
Weight		kg	0.6		1.3			2.2			~ 7			
Wall fixing screws			M4 x 50		M5 x 60			M5 x 70			M6 x 110			
Maximun suggested flow rate			Please look at the flow rate curves at page C3.12											
Fluid			Compressed air.											
Notes on use			The maximum inlet pressure for the version with RA automatic condensate drainage must not exceed 10 bar.											

SYNOPTIC, SIZES AND VERSIONS

F+D	100	1/4	5	RMSA	
ELEMENT	SIZE	THREADED PORT	DEGREE OF FILTRATION	TYPE OF CONDENSATE DRAIN	
F+D	100	1/4 3/8	5 = 5 µm	RMSA SAC RMSA RA	RMSA: drain with manual condensate discharge and automatic discharge at zero pressure RA: automatic drain with condensate discharge, independent of pressure and flow rate. (for size 300 and 400). Version conveys the draining by inserting the pipe having internal diameter 6 mm in the lower port. SAC: automatic drain with condensate discharge. Operates by pressure drop – requires variable air take-offs. (for size 100 and 200)
	200	1/4 3/8 1/2			
	300	1/2 3/4			
	400	1 1 1/4 1 1/2 2			

DIMENSIONS FIL + DEP

100 - 200 - 300

400

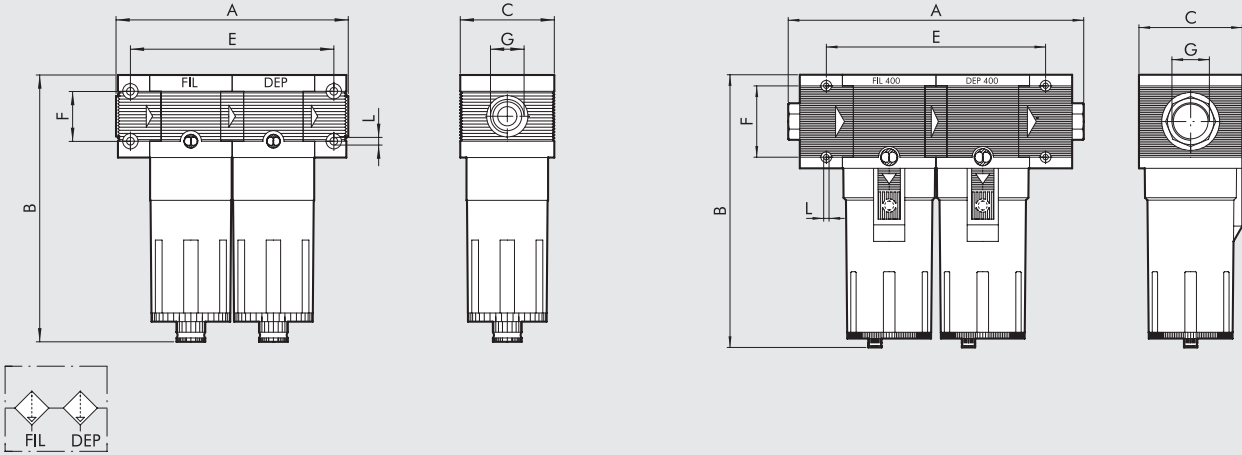

	FIL + DEP 100		FIL + DEP 200			FIL + DEP 300			FIL + DEP 400			
		1/4" 3/8"	1/4"	3/8"	1/2"	1/2"	3/4"	1"	1"	1" 1/4"	1" 1/2"	2"
Threaded port G												
A		121		149		175	177		330 to 360		388 to 418	
B	RMSA	144		175			195		320			
	RA	-		179			199		324			
	SAC	148		179			199		324			
C		50		63			72		118			
E		106		134			157		247			
F		26		36			42		80			
L		Hole for M4 screws		Hole for M5 screws			Hole for M5 screws		Hole for M6 screws			

ORDERING CODES

Code	Description	Code	Description
F+D Skillair® 100			
3289001	F+D 100 1/4 5 RMSA-RMSA	4489001	F+D 300 1/2 5 RMSA-RMSA
3289005	F+D 100 1/4 5 SAC-RMSA	4489002	F+D 300 1/2 5 RA-RA
3289006	F+D 100 1/4 5 SAC-SAC	4589001	F+D 300 3/4 5 RMSA-RMSA
3389001	F+D 100 3/8 5 RMSA-RMSA	4589002	F+D 300 3/4 5 RA-RA
3389005	F+D 100 3/8 5 SAC-RMSA	4689001	F+D 300 1 5 RMSA-RMSA
3389006	F+D 100 3/8 5 SAC-SAC	4689002	F+D 300 1 5 RA-RA
F+D Skillair® 200			
3489001	F+D 200 1/4 5 RMSA-RMSA	6189001	F+D 400 1 5 RMSA-RMSA
3489005	F+D 200 1/4 5 SAC-RMSA	6189002	F+D 400 1 5 RA-RA
3489006	F+D 200 1/4 5 SAC-SAC	6289001	F+D 400 1 1/4 5 RMSA-RMSA
3589001	F+D 200 3/8 5 RMSA-RMSA	6289002	F+D 400 1 1/4 5 RA-RA
3589005	F+D 200 3/8 5 SAC-RMSA	6389001	F+D 400 1 1/2 5 RMSA-RMSA
3589006	F+D 200 3/8 5 SAC-SAC	6389002	F+D 400 1 1/2 5 RA-RA
3689001	F+D 200 1/2 5 RMSA-RMSA	6489001	F+D 400 2 5 RMSA-RMSA
3689005	F+D 200 1/2 5 SAC-RMSA	6489002	F+D 400 2 5 RA-RA
3689006	F+D 200 1/2 5 SAC-SAC		

UNITS
FIL + DEP Skillair®

Skillair® ACCESSORIES

MOUNTING BRACKET FOR REG.

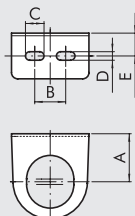

Code	Description
9200701	SF100- BIT-ND1/4
9400701	SF200-ND-3/8 1/2
9400702	SF300

Code	A	B	C	D	E
9200701	32	20	12	5.5	14.2
9400701	42	40	12	5.5	15
9400702	48	49	12	5.5	17

PRESSURE GAUGES

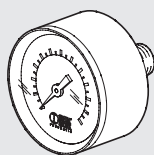

Code	Description
9700101	M 40 1/8 012
9700102	M 40 1/8 04
9800101	M 50 1/8 012
9800102	M 50 1/8 04
9900101	M 63 1/4 012

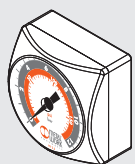

9700109	M 40x40 1/8 04
9700110	M 40x40 1/8 012

COIL 22 mm FOR APR AND V3V ELPN

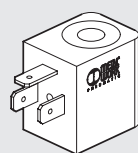

Code	Description
W0215000151	Coil 22 Ø 8 BA 2W-12VDC
W0215000101	Coil 22 Ø 8 BA 2W-24VDC
W0215000111	Coil 22 Ø 8 BA 3.5VA-24VAC
W0215000121	Coil 22 Ø 8 BA 3.5VA-110VAC
W0215000131	Coil 22 Ø 8 BA 3.5VA-220VAC

Electrical connection DIN 43650 B-IND

COIL 22 mm FOR APR AND V3V ELPN

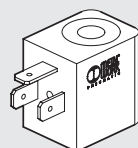

Code	Description
W0215000251	Coil 22 Ø 8 BA 2W-12VDC UR
W0215000201	Coil 22 Ø 8 BA 2W-24VDC UR
W0215000211	Coil 22 Ø 8 BA 3.5VA-24VAC UR
W0215000221	Coil 22 Ø 8 BA 3.5VA-110VAC UR
W0215000231	Coil 22 Ø 8 BA 3.5VA-220VAC UR

Electrical connection DIN 43650 B-IND



COIL 30 mm FOR APR AND V3V ELPN

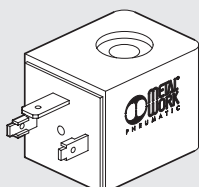

Code	Description
W0210010100	Coil 30 Ø 8 2W-24VDC
W0210011100	Coil 30 Ø 8 3.5VA-24VAC 50/60 HZ
W0210012100	Coil 30 Ø 8 3.5VA-110VAC 50/60 HZ
W0210013100	Coil 30 Ø 8 3.5VA-220VAC 50/60 HZ

Electrical connection DIN 43650 - A

COIL 30 mm FOR CDV CDML LUBRICATOR

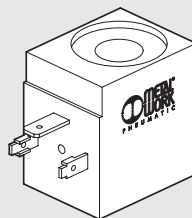

Code	Description
W0216001001	Coil 30 Ø13 10W-24VDC
W0216001011	Coil 30 Ø13 13VA-24VAC 50/60HZ
W0216001021	Coil 30 Ø13 13VA-110VAC 50/60HZ
W0216001031	Coil 30 Ø13 13VA-220VAC 50/60HZ

Electrical connection DIN 43650 - A

KIT FOR COIL EEXM (FOR V3V-APR-LUB)

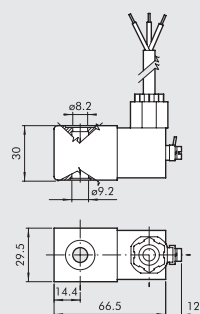

Code	Description
0227606913	Kit for coil 30 24 VDC EEXMT5 cable 3 m
0227606915	Kit for coil 30 24 VDC EEXMT5 cable 5 m
0227608013	Kit for coil 30 24 VAC EEXMT5 cable 3 m
0227608015	Kit for coil 30 24 VAC EEXMT5 cable 5 m
0227608023	Kit for coil 30 110 VAC EEXMT5 cable 3 m
0227608025	Kit for coil 30 110 VAC EEXMT5 cable 5 m
0227608033	Kit for coil 30 230 VAC EEXMT5 cable 3 m
0227608035	Kit for coil 30 230 VAC EEXMT5 cable 5 m

According to Atex 2014/34/EU rule,
 ⓧ II 2G Ex mb IIC T4/T5 Gb
 ⓧ II 2D Ex tb IIIC T130/T95 °C IP66 Db
 N.B.: Supplied complete with adapter for Ø8 mm sleeve

ELECTRIC CONNECTOR 22 mm FOR COILS DIN 43650 B-IND

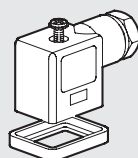

Code	Description
W0970510011	Connector standard
W0970510012	Connector 22 LED 24V
W0970510013	Connector 22 LED 110V
W0970510014	Connector 22 LED 220V
W0970510015	Connector 22 LED VDR 24V
W0970510016	Connector 22 LED VDR 110V
W0970510017	Connector 22 LED VDR 220V
W0970510070	Connector 22 ATEX II 2 GD

ELECTRIC CONNECTOR 30 mm FOR COILS DIN 43650-A

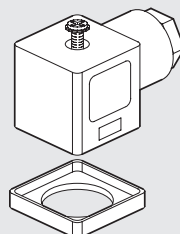

Code	Description
W0970520033	Connector 30 STD
W0970520034	Connector 30 LED 24V
W0970520035	Connector 30 LED 110V
W0970520036	Connector 30 LED 220V
W0970520037	Connector 30 LED VDR 24V
W0970520038	Connector 30 LED VDR 110V
W0970520039	Connector 30 LED VDR 220V

M8 STRAIGHT CONNECTOR WITH CABLE FOR PRESSURE SWITCHES

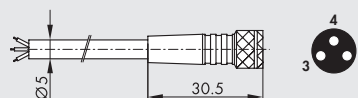

Pin	Cable color
1	Brown
3	Blue
4	Black

Code	Description
02400A0100	M8 female 3 PIN HIGH FLEX CL6 connector with cable L = 1 m
02400A0250	M8 female 3 PIN HIGH FLEX CL6 connector with cable L = 2.5 m
02400A0500	M8 female 3 PIN HIGH FLEX CL6 connector with cable L = 5 m
02400A1000	M8 female 3 PIN HIGH FLEX CL6 connector with cable L = 10 m

Very flexible cables, class 6 according to IEC 60228

M8 ADAPTER CABLE FOR CONNECTING THE PRESSURE SWITCH TO THE EB 80 E CM DIGITAL INPUTS MODULE

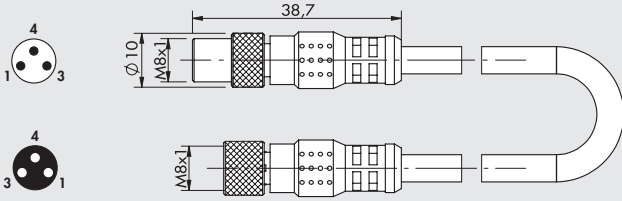

Code	Description
0240010501	M8-M, M8-F 3-pole adapter with cable L = 0.3 m

Note: Can be used to connect the pressure switch to the module of digital INPUT 501 of the EB 80 valves, to the additional M8 INPUT module of the CM valves and to the Profibus-DP IP67 M8 input. Contact type NO (Normally open)

M8F	M8M	Function
pin 1	pin 1	Power supply +
pin 3	pin 2	Signal NO
pin 4	disconnect	

KIT COIL SIDE 22 IP65 (FOR V3V-APR-LUB)



Code	Description
0222100100	Kit for coils 22 - IP65

Improved IP65 protection, even after prolonged exposure to atmospheric agents. Applicable to valves with a technopolymer control.

CONNECTOR KIT FOR SKILLAIR CODE A

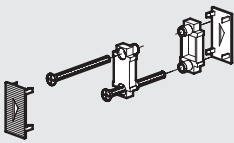

Code	Description
9230301	Connector kit 100
9330301	Connector kit 200
9430301	Connector kit 300
9630301	Connector kit 400

INPUT/OUTPUT END PLATE KIT

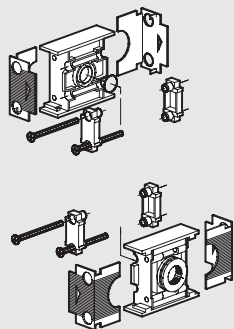

Code	Description
9230401	IN/OUT end plate kit 100 1/4
9330501	IN/OUT end plate kit 100 3/8
9330601	IN/OUT end plate kit 200 1/4
9330701	IN/OUT end plate kit 200 3/8
9330801	IN/OUT end plate kit 200 1/2
9430701	IN/OUT end plate kit 300 1/2
9530901	IN/OUT end plate kit 300 3/4
9531001	IN/OUT end plate kit 300 1
9631001	IN/OUT end plate kit 400 1
9631101	IN/OUT end plate kit 400 1 1/4
9631201	IN/OUT end plate kit 400 1 1/2
9631301	IN/OUT end plate kit 400 2

FILTER BOWL

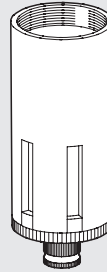

Code	Description
9253301	Spares TF 100 RMSA
9255301	Spares TF 100 SAC
9353301	Spares TF 200 RMSA
9355301	Spares TF 200 SAC
9453401	Spares TF 300 RA
9453301	Spares TF 300 RMSA
9653401	Spares TF 400 RA
9653301	Spares TF 400 RMSA

LUBRICATOR BOWL

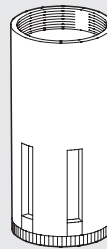

Code	Description
9253501	Spares TL 100
9202503	Spares TL 100 CA
9202502	Spares TL 100 CD
9202501	Spares TL 100 ML
9353501	Spares TL 200
9302501	Spares TL 200 CA
9302503	Spares TL 200 CD
9302502	Spares TL 200 ML
9453501	Spares TL 300
9202401	Spares TL 300 CA
9202403	Spares TL 300 CD
9202402	Spares TL 300 ML
9653501	Spares TL 400
9653502	Spares TL 400 CA
9653504	Spares TL 400 CD
9653503	Spares TL 400 ML

FILTERING ELEMENTS

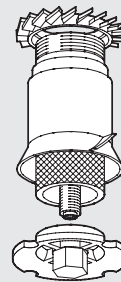

Code	Description
9251705	Spares FP 100 5
9251706	Spares FP 100 20
9251707	Spares FP 100 50
9351705	Spares FP 200 5
9351706	Spares FP 200 20
9351707	Spares FP 200 50
9451705	Spares FP 300 5
9451706	Spares FP 300 20
9451707	Spares FP 300 50
9651705	Spares FP 400 5
9651706	Spares FP 400 20
9651707	Spares FP 400 50

FILTERING/PURIFICATION ELEMENTS

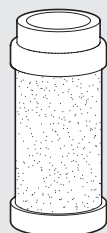

Code	Description
9251711	Spares FP DEP. 100
9351711	Spares FP DEP. 200
9451711	Spares FP DEP. 300
9651711	Spares FP DEP. 400

CARTRIDGE AC

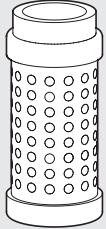

Code	Description
9251713	Spares cartridge 100 AC
9351713	Spares cartridge 200 AC
9451713	Spares cartridge 300 AC
9651712	Spares cartridge 400 AC

UPPER COVER FOR REGULATOR AND FR

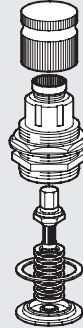

Code	Description
9250800	Spares CS 100 02
9250810	Spares CS 100 04
9250811	Spares CS 100 08
9250812	Spares CS 100 012
9350800	Spares CS 200 02
9350810	Spares CS 200 04
9350811	Spares CS 200 08
9350812	Spares CS 200 012
9450805	Spares CS 300 04
9450806	Spares CS 300 08
9450807	Spares CS 300 012
9450808	Spares CS 300 02

VENTURI LUBRICATOR DIAPHRAGM

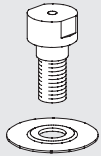

Code	Description
9252001	Spares MB 100 ND 1/4
9352001	Spares MB 200 ND 3/8-1/2
9452001	Spares MB 300
9652601	Spares MB 400

COMPLETE POPPET FOR REGULATORS

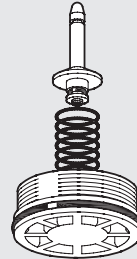

Code	Description
9250704	Spares OTR 100
9350704	Spares OTR 200
9450704	Spares OTR 300
9650704	Spares OTR 400

TRANSPARENT LUBRICATOR COVER

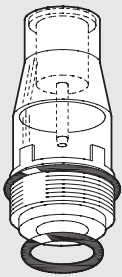

Code	Description
9251302	Spares CVL 100-200-300-400 BIT

COMPLETE POPPET FOR FR

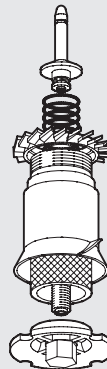

Code	Description
9250902	Spares OTFR 100 5
9250903	Spares OTFR 100 20
9250904	Spares OTFR 100 50
9350902	Spares OTFR 200 5
9350903	Spares OTFR 200 20
9350904	Spares OTFR 200 50
9450902	Spares OTFR 300 5
9450903	Spares OTFR 300 20
9450904	Spares OTFR 300 50

SPRINGS FOR REDUCERS AND FRs

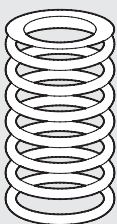

Code	Description
9250605	Spares MO 100 02
9250606	Spares MO 100 04
9250607	Spares MO 100 08
9250608	Spares MO 100 012
9350605	Spares MO 200 02
9350606	Spares MO 200 04
9350607	Spares MO 200 08
9350608	Spares MO 200 012
9450605	Spares MO 300 04
9450606	Spares MO 300 08
9450607	Spares MO 300 012
9450608	Spares MO 300 02

UPPER COVER DISASSEMBLY SPANNER

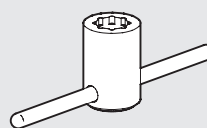

Code	Description
9220701	Spares cover spanner

REG AND FR VISUAL DOME DISASSEMBLY SPANNER

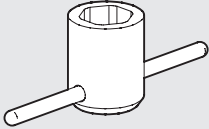

Code	Description
9220401	Spares dome dis. spanner 100
9323401	Spares dome dis. spanner 200
9420401	Spares dome dis. spanner 300

PROVISION FOR SOLENOID CONTROL TO CNOMO FOR APR-300

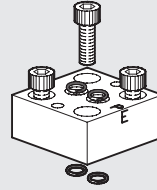

Code	Description
9454001	Spares PCE to Cnomo

POPPET DISASSEMBLY SPANNER (FOR REG.)

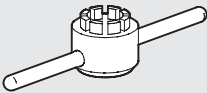

Code	Description
9220501	Spares R cap disass. WR. 100
9323501	Spares R cap disass. WR. 200
9420501	Spares R cap disass. WR. 300

PROVISION FOR MICRO SOLENOID CONTROL FOR APR-300

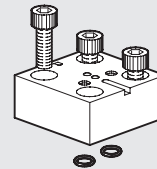

Code	Description
9453601	Spares PCE micro

POPPET DISASSEMBLY SPANNER (FOR FR)

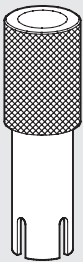

Code	Description
9220801	Spares FR cap disass. WR. 100
9320801	Spares FR cap disass. WR. 200
9420801	Spares FR cap disass. WR. 300

PROVISION FOR PNEUMATIC CONTROL FOR APR-300

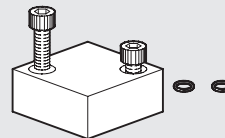

Code	Description
9453701	Spares PCP pneumatic

CAP DISASSEMBLY SPANNER

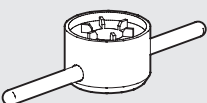

Code	Description
9220601	Spares cap disass. 100
9323601	Spares cap disass. 200
9420601	Spares cap disass. 300

CNOMO SOLENOID CONTROL FOR APR and V3V 300-400

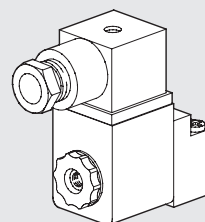

Code	Description
9453901	Spares CEC Cnomo 24CC
9453902	Spares CEC Cnomo 24V
9453903	Spares CEC Cnomo 110V
9453904	Spares CEC Cnomo 220V

**MICRO SOLENOID CONTROL FOR APR-300 and V3V 300
(NO MORE IN THE CATALOGUE)**

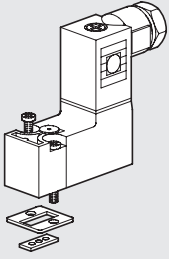

Code	Description
9453801	Spares CEM micro 24CC
9453802	Spares CEM micro 24V
9453803	Spares CEM micro 110V
9453804	Spares CEM micro 220V

INTERMEDIATE COVER PLATE

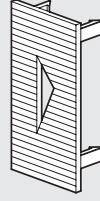

Code	Description
9152107	Spares intermediate cover plate 100
9152114	Spares intermediate cover plate 200
9152108	Spares intermediate cover plate 300
9152117	Spares intermediate cover plate 400

KEY-OPERATED V3V 400

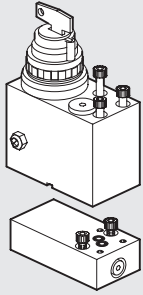

Code	Description
9455401	Spares kit C.C. 400

AUTOMATIC DRAIN (RA)

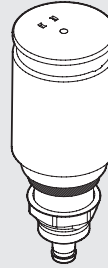

Code	Description
9000802	Spares RA automatic drain

MANUAL LOCKABLE V3V 400

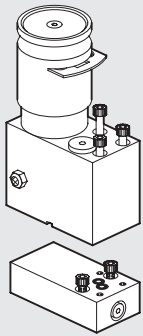

Code	Description
9455601	Spares kit lockable 400

AUTOMATIC DRAIN (SAC)



Code	Description
9000803	Spares SAC automatic drain

INPUT/OUTPUT COVER PLATE

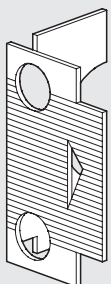

Code	Description
9152103	Spares OUTPUT cover plate 100
9152105	Spares INPUT cover plate 100
9152115	Spares OUTPUT cover plate 200
9152116	Spares INPUT cover plate 200
9152104	Spares OUTPUT cover plate 300
9152106	Spares INPUT cover plate 300
9152118	Spares OUTPUT cover plate 400
9152119	Spares INPUT cover plate 400

NOTES