

Option selector

Bowl/ Element

C Standard
H High flow

Port

2 1/4"
3 3/8"
4 1/2"
6 3/4"

Thread

A (1/8 PTF gauge ports)
B (1/8 PTF gauge ports)
G ISO G parallel (1/8 ISO Rc gauge ports)
N No thread (basic unit)

Service life indicator

D Mechanical service life indicator
N Without indicator

Drain

A Automatic
M Manual
Q Manual, 1/4 turn

Bowl

D Metal
P Transparent with guard
R Metal with Pyrex sight glass

Element

O Coalescing

F64★ - ★★ - ★★

TECHNICAL FEATURES

Fluid: Compressed air

Maximum pressure:

Guarded transparent bowl: 10 bar (150 psig) Metal

bowl: 17 bar (250 psig)

Operating temperature*:

Transparent bowl: -20° ... +50°C (0° ... +125°F) Metal

bowl: -20° ... +65°C (0° ... +150°F)

* Air supply must be dry enough to avoid ice formation at temperatures below +2°C (+35°F). Particle removal: Down to 0,01 µm

Air quality: Within ISO 8573-1, Class 1.7.2 Maximum remaining oil content in outlet air: 0,01 mg/m3 at +21°C (+70°F)

with an inlet concentration of 17 ppm Maximum flow at 6,3 bar (90 psig) inlet pressure**: 16 dm3/s (34 scfm) F64C, 28 dm3/s (60 scfm) F64H

** to maintain stated oil removal performance. Automatic drain connection: 1/8"

Automatic drain operating conditions: Minimum pressure: 0,7 bar (10 psig). Drain opens when bowl pressure drops below 0,2 bar (3 psig)

Minimum air flow:

1 dm3/s (2 scfm) required to close drain Nominal bowl size: 0,2 litre (7 fluid oz) Materials:

Body: Zinc

Bowl:

Metal: Aluminium

Transparent, optional: Polycarbonate

Metal bowl liquid level indicator lens, standard:

Grilamid

Metal bowl sight glass, optional: Pyrex Element:

Composite materials

Elastomers: Synthetic rubber

Mechanical service indicator materials:

Body: Transparent Nylon

Internal parts: Acetal

Spring: Stainless steel

Elastomers: NBR

REPLACEMENT ITEMS

Service kit

contains required items circled: 4380-200

Prismatic sight glass 4380-040

Pyrex sight glass 4380-040

Pyrex sight glass 4380-041

Filter element:

F64C 4344-01

F64H 4344-02

Manual drain 684-84

Automatic drain 3000-97

Mechanical service Indicator (1) 5797-50

INSTALLATION

1. Install unit vertically in air line -
 - vertically (bowl down),
 - with air flow in direction of arrow on body,
 - upstream of regulators, lubricators, and cycling valves,
 - as close as possible to the air supply when used as a main line filter,
 - as close as possible to the device being serviced when used as a final filter.
2. Before assembling the basic unit into the yoke the port seal o-rings should be lightly smeared with o-ring grease.
3. Locate clamp ring under lugs on top of yoke, offer basic unit into yoke with directional arrows correctly aligned (an interference fit prevents assembly if misaligned) before engaging and fully tightening the clamp ring.
4. Turn bowl or bowl guard fully clockwise into body before pressurizing. Lock symbols on body and bowl guards must align.
5. Auto-drain units may be fitted with a short drain pipe and connector, minimum 5 mm bore, to the G1/8 bottom outlet.
6. Push bowl, or bowl with guard, into body and turn fully clockwise before pressurizing.
7. Install a Norgren general purpose filter with a 5 µm element upstream of the oil removal filter to obtain maximum element service life.
8. Turn bowl into body until arrowhead on bowl is aligned with or to the right of the arrowhead on the body.

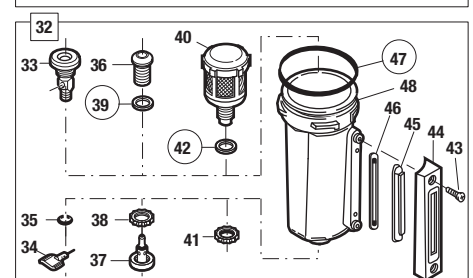
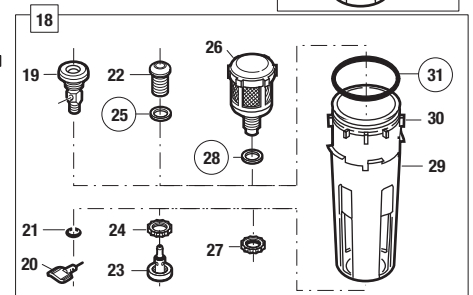
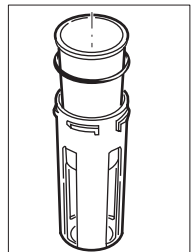
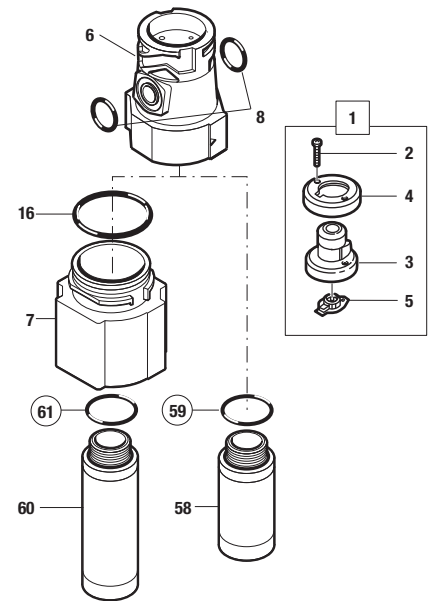
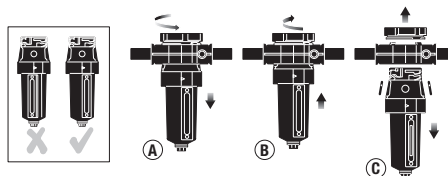

SERVICING

1. Open manual drain to expel accumulated liquids. Keep liquids below element (58, 60).
2. To operate automatic drain manually, lift operating pin in bottom outlet with a blunt rod.
3. Replace filter element when pressure drop across element exceeds 0,7 bar (10 psig). The mechanical service indicator shows approximately full red.

DIASSEMBLY

1. Shut off inlet pressure. Reduce pressure in inlet and outlet lines to zero.
2. For ease of maintenance the unit can be removed from the yoke by unscrewing the clamp ring, which will jack the unit out down wards.
3. Lift and turn the filter bowl counterclockwise and remove with bowl o-ring.
4. Disassemble in general accordance with the item numbers on exploded view. Do not remove the drains or the service indicator unless replacement is necessary. Remove and replace only if they malfunction.

CLEANING

1. Element (58, 60) cannot be cleaned. Clean plastic bowl and lens (45) with warm water only. Clean indicator (1) with dry, clean cloth. Clean other parts with warm water and soap.
2. Rinse and dry parts. Blow out internal passages in body (6) with clean, dry compressed air.
3. Inspect parts. Replace those found to be damaged. Replace plastic bowl with a metal bowl if plastic bowl shows signs of cracking or cloudiness.

ASSEMBLY

1. Lubricate o-rings with o-ring grease.
2. Assemble the unit as shown on the exploded view.
3. Arrows on indicator (3) and body (6) must point in same direction. Push bowl, or bowl with guard, into body and turn fully clockwise.
4. Torque Table
Torque in

Item	N-m	(Inch-Pounds)
58, 60 (Element)	0,5 to 1	(5 to 9)

5. Turn bowl or bowl with guard fully clockwise into body.

CAUTION

Water vapor will pass through these units and could condense into liquid form downstream as air temperature drops. Install an air dryer if water condensation could have a detrimental effect on the application.

WARNING

Polycarbonate plastic bowls can be damaged and possibly burst if exposed to such substances as certain solvents, strong alkalis, compressor oils containing ester-based additives or synthetic oils. Fumes of these substances in contact with the polycarbonate bowl, externally or internally, can also result in damage. Clean with warm water only. Use metal bowl in applications where a plastic bowl might be exposed to substances that are incompatible with polycarbonate. Before using these products with fluids other than air, for non industrial applications, or for life-support systems consult Norgren.

