

**B38 - ★★ - ★★**

Port	Material	Mounting Options	Drain	Element	Spring (Outlet Pressure Range) *	Thread Form
2 1/4"	0 Aluminium with Nitrile elastomers	0 None 1 Bracket and nut 2 Nut only 3 Handwheel and nut 4 Handwheel with bracket and nut 5 Handwheel	B Manual	1 5 µm 2 25 µm	C 0,04 ... 2 bar (0,6 ... 29 psig) F 0,07 ... 4 bar (1 ... 58 psig) K 0,25 ... 7 bar (3,6 ... 102 psig)	A PTF B ISO Rc taper D ISO G K API

\* Outlet pressure can be adjusted to pressures in excess of, and less than, those specified.  
Do not use these units to control pressures outside of the specified ranges.

**TECHNICAL DATA**

Fluid: Compressed air

Maximum pressure:

Aluminium: 20 bar (290 psig)

Operating temperature: -40° ... +80°C (-40° ... +176°F)\*

\* Air supply must be dry enough to avoid ice formation at temperatures below +2°C (+36°F).

Particle removal: 5 µm or 25 µm filter element

Air quality: Within ISO 8573-1, Class 3 and Class 5 (particulates)

Typical flow with 7 bar (102 psig) inlet pressure, 1 bar (14,5 psig) set pressure and 0,05 bar (0,7 psig) drop from set: 8 dm<sup>3</sup>/s (17 scfm)

Gauge ports: 1/4" as per main ports

Materials:

Body: Aluminium

Bonnet: Aluminium

Bowl: Aluminium

Adjusting screw: steel

Element

5 µm: Stainless steel

25 µm: Vyon

Elastomers: Synthetic rubber

Diaphragm: Nitrile

Valve seat: Stainless steel

Valve spring: Stainless steel

Valve: Nitrile

Valve cap: Aluminium

**REPLACEMENT ITEMS**

Service Kit (includes items circled on exploded view):

Relieving

2 bar R38-100R

4 & 7 bar R38-101R

Non relieving

2 bar R38-100NR

4 & 7 bar R38-101NR

Filter section

5 µm aluminium B38-100A-5

25 µm aluminium B38-100A-25

**PANEL MOUNTING DIMENSIONS**

Panel mounting hole diameter: 41 mm (1.61")

Maximum panel thickness: 0 ... 6 mm (0 ... 0.24")

**INSTALLATION**

1. Shut off air pressure. Install filter/regulator in air line

- vertically (bowl down),
- with air flow in direction of arrow on body.
- upstream of lubricators and cycling valves,
- as close as possible to the device being serviced.

2. Connect piping to proper ports using pipe thread sealant on male threads only. Do not allow sealant to enter interior of unit.

3. Install a pressure gauge or plug the gauge ports. Gauge ports can also be used as additional outlets for regulated air.

**ADJUSTMENT**

1. Before applying inlet pressure to filter/regulator, turn adjustment (2) counterclockwise to remove all force on regulating spring (7).
2. Apply inlet pressure, then turn adjustment (2) clockwise to increase and counterclockwise to decrease outlet pressure setting.
3. Always approach the desired pressure from a lower pressure. When reducing from a higher to a lower setting, first reduce to some pressure less than that desired, then bring up to the desired pressure.

**NOTE**

With non-relieving filter/regulators, make pressure reductions with some air flow in the system. If made under no flow (dead-end) conditions, the filter/regulator will trap the over-pressure in the downstream line.

4. Once required pressure is achieved tighten locknut (3) to lock setting.

**SERVICING**

1. Regularly open drain to expel accumulated liquids. Keep liquids below element retainer (13).
2. At approximately 6 month intervals it is advisable to remove the bowl assembly by removing the securing screws (4) and unscrewing the element retainer (13) to remove the element (15) for inspection. Since the direction of air flow is from the inside of the element to the outside, a clean exterior is not an indication of freedom from contamination. If the filter element shows evidence of blockage, replace with new element. Clean the element retainer (13) and the upper and lower gaskets (14) before replacing the filter element – avoiding excessive overtightening of the retainer. Inspect the bowl O-ring (16) for damage and renew if necessary.
3. Clean or replace filter element when dirty.

**DISASSEMBLY**

1. Filter/regulator can be disassembled without removal from air line.
2. Shut off inlet pressure. Reduce pressure in inlet and outlet lines to zero.
3. Turn adjustment screw fully counterclockwise.
4. Disassemble in general accordance with the item numbers on exploded view. Do not remove the drain unless replacement is necessary. Remove and replace drain only if it malfunctions.

**CLEANING**

1. Rinse and dry parts. Blow out internal passages in body (22) with clean, dry compressed air. Blow air through filter element (15) from outside to inside to remove surface contaminants.
2. Inspect parts. Replace those found to be damaged.

**ASSEMBLY**

1. Lubricate threads and nose of adjusting screw (2) at regular intervals with suitable grease eg. Speerol APT2.
2. Lubricate seals (16, 23, 26) with light coat of good quality grease.
3. Assemble the unit as shown on the exploded view.
4. Torque Table

Item	Torque In Nm (Inch-Pounds)
4 (screws, aluminium model)	3,3 (30)
24 (valve cap, aluminium model)	8 (72)

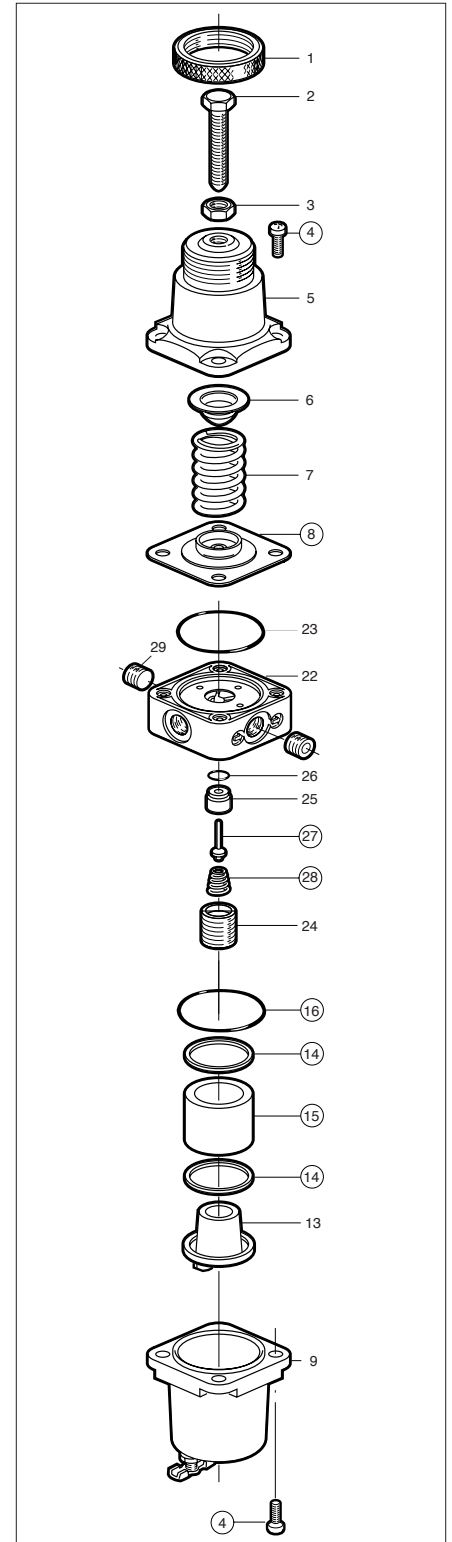

## B38 - Aluminium Precision Filter/Regulator Installation & Maintenance Instructions



### CAUTION

Water vapor will pass through these units and could condense into liquid form downstream as air temperature drops. Install an air dryer if water condensation could have a detrimental effect on the application.

### WARNING

These products are intended for use in industrial compressed air systems only. Do not use these products where pressures and temperatures can exceed those listed under Technical Data.

If outlet pressure in excess of the filter/regulator pressure setting could cause downstream equipment to rupture or malfunction, install a pressure relief device downstream of the filter/regulator. The relief pressure and flow capacity of the relief device must satisfy system requirements.

The accuracy of the indication of pressure gauges can change, both during shipment (despite care in packaging) and during the service life. If a pressure gauge is to be used with these products and if inaccurate indications may be hazardous to personnel or property, the gauge should be calibrated before initial installation and at regular intervals during use. Before using these products with fluids other than air, for non industrial applications, or for life-support systems consult Norgren.