

Model Series VS18/VS26

Valve advantage

Installation &
Maintenance
Instruction

Engineering
GREAT Solutions

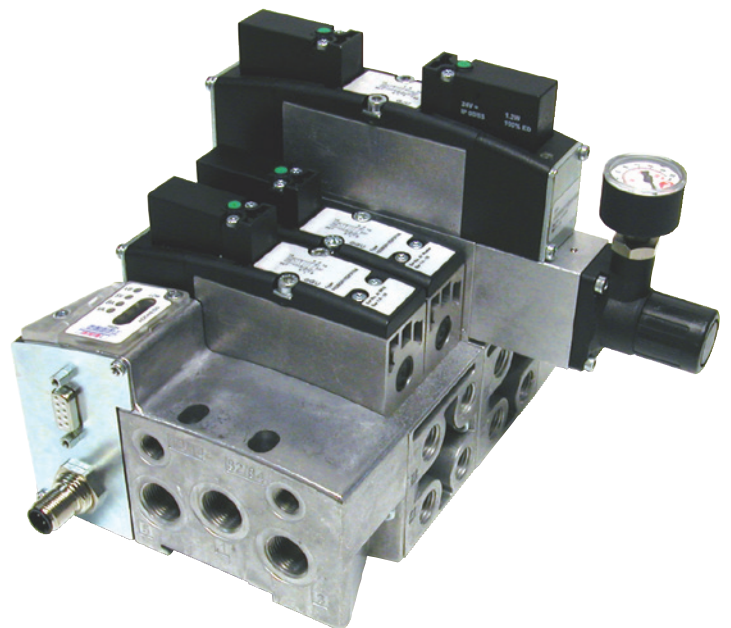
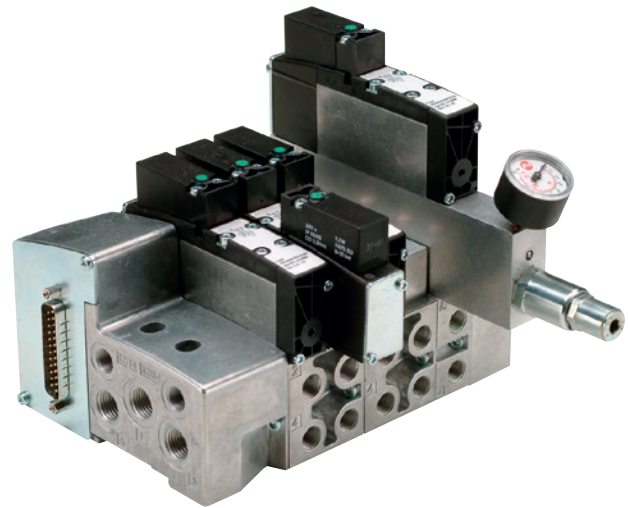

Before starting work read these instructions

Model VS2672926-KG00

1 CONTENT

1	CONTENT	2
2	VS18/VS26-SYSTEM OVERVIEW	5
3	SAFETY, WARNING	6
4	TECHNICAL DATA	7
4.1	SPECIFICATION	7
4.1.1	Ambient temperature	7
4.1.2	Medium temperature	7
4.1.3	Medium	7
4.1.4	Air quality	7
4.2	MATERIALS	7
4.3	PNEUMATIC	7
4.3.1	Response times VS valves	7
4.3.2	Flow	8
4.3.3	Maximum cycling rate	8
4.3.4	Minimum impulse on bistable valves	8
4.3.5	Important information for 2x2/2 valves	8
4.4	ELECTRICAL	9
4.4.1	Voltage tolerances	9
4.4.2	Required performance of power supply unit	9
4.4.3	Power supply and precautions	9
4.5	COMPLIANCE AND APPROVALS	9
4.5.1	CE marking	9
4.5.2	ATEX (Directive 2014/34/EU) for 24V DC only	9
4.5.3	ISO standard	10
4.5.4	Fieldbus standards	10
4.5.5	CNOMO standard	10
4.5.6	DIN standard	10
4.5.7	UL/CSA approval	10
5	INSTALLATION AND MAINTENANCE MECHANICAL	11
5.1	INSTALLATION	11
5.1.1	Tools	11
5.1.2	Tightening torque	11
5.1.3	Port identification	11
5.1.4	Assembly of VS18/VS26 valve islands	12
5.1.5	Valve identification labels	15
5.1.6	Internal/external pilot air supply	15
5.1.7	Multi pressure	16
5.1.8	DIN-rail assembly	17
5.1.9	Installation instruction in case of raised vibrations	18
5.1.10	Sandwich plates	18
5.1.11	Replacement of valves	20
5.1.12	Replacement of pilot valves	21
5.1.13	Manual override set-up kit	22
5.1.14	Blanking plug for base connector hole	23
5.2	MAINTENANCE	23
5.2.1	Lubrication	23
5.2.2	Spare parts	24
6	SINGLE STATION SUB-BASE	25
6.1	GENERAL INFORMATION	25
6.1.1	24V DC power supply	25
6.1.2	115V AC power supply	25
6.1.3	Max current load on valve connectors with 24V DC	25
6.1.4	Max current load on valve connectors with 115V AC	25
6.2	VARIANT WITH M12 CONNECTOR	26
6.2.1	Pin assignment (acc. VDMA 24571)	26
6.3	VARIANT WITH NPTF1/2" CONDUIT WITH FLYING LEADS	26
6.3.1	Wiring information	26



7	MULTIPOLE	27
7.1	GENERAL INFORMATION	27
7.1.1	24V DC power supply	27
7.1.2	115V AC power supply	27
7.1.3	Max current load on valve connectors with 24V DC	27
7.1.4	Max current load on valve connectors with 115V AC	27
7.2	VARIANTS WITH D-SUB CONNECTORS	28
7.2.1	D-Sub assembly / Installation of PCB	28
7.2.2	Pin assignment	29
7.3	VARIANT WITH NPTF1" CONDUIT ENTRY WITH TERMINALS	31
7.3.1	NPTF1" conduit entry with terminals assembly / Installation of PCB	31
7.3.2	Pin assignment	33
7.4	VARIANT WITH M23 CONNECTOR	34
7.4.1	M23 assembly / Installation of PCB	34
7.4.2	Pin assignment	35
8	FIELDBUS	36
8.1	GENERAL INFORMATION	36
8.1.1	Power supply and pin assignment	36
8.1.2	Max. current load on valve connectors	36
8.1.3	Fieldbus assembly / Installation of PCBs (excluding AS-Interface)	37
8.1.4	AS-Interface assembly / Installation of PCBs	38
8.2	PROFIBUS DP	39
8.2.1	Profibus DP pin assignment	39
8.2.2	Profibus DP wiring	39
8.2.3	Profibus DP address and baud rate setting	40
8.2.4	Profibus DP output addressing	41
8.2.5	Diagnostics	42
8.2.6	Profibus DP LED indicators	42
8.2.7	Profibus DP commissioning	42
8.2.8	GSD file	42
8.2.9	Profibus DP valve island expansion	42
8.2.10	More information on Profibus DP	42
8.3	DEVICENET	43
8.3.1	DeviceNet pin assignment	43
8.3.2	DeviceNet wiring	43
8.3.3	DeviceNet address and baud rate setting	44
8.3.4	DeviceNet output addressing	44
8.3.5	Diagnostics	44
8.3.6	DeviceNet LED indicators	44
8.3.7	DeviceNet EDS files and commissioning	45
8.3.8	DeviceNet valve island expansion	45
8.3.9	More information on DeviceNet	45
8.4	CANOPEN	46
8.4.1	CANopen pin assignment	46
8.4.2	CANopen wiring	46
8.4.3	CANopen address and baud rate setting	47
8.4.4	CANopen output addressing	48
8.4.5	Diagnostics	48
8.4.6	CANopen LED indicators	48
8.4.7	CANopen commissioning	48
8.4.8	CANopen valve island expansion	48
8.4.9	More information on CANopen	48
8.5	INTERBUS-S	49
8.5.1	Interbus-S pin assignment	49
8.5.2	Interbus-S wiring	50
8.5.3	Interbus-S address and baud rate setting	50
8.5.4	Interbus-S output addressing	50
8.5.5	Diagnostics	50
8.5.6	Interbus-S LED indicators	50
8.5.7	Interbus-S ID and length codes	51
8.5.8	Interbus-S commissioning	51
8.5.9	Interbus-S valve island expansion	51
8.5.10	More information on Interbus-S	51

8.6	AS-INTERFACE	52
8.6.1	AS-Interface pin assignment	52
8.6.2	AS-Interface wiring	52
8.6.3	AS-Interface address and baud rate setting	52
8.6.4	AS-Interface single slave valve island configurations and settings	53
8.6.5	AS-Interface single slave output addressing	53
8.6.6	AS-Interface double slave valve island configurations and settings	54
8.6.7	AS-Interface double slave output addressing	55
8.6.8	Diagnostics	55
8.6.9	AS-Interface LED indicators	55
8.6.10	AS-Interface ID and I/O configuration codes	55
8.6.11	AS-Interface commissioning	55
8.6.12	AS-Interface valve island expansion	55
8.6.13	More information on AS-Interface	55
9	VALVE ISLAND EXPANSION	56
9.1	GENERAL INFORMATION	56
9.2	ASSEMBLY OF SINGLE ADD-ON STATIONS FOR MULTIPOLE AND FIELDBUS VALVE ISLANDS	56
10	USE IN AREAS WITH POTENTIALLY EXPLOSIVE ATMOSPHERE (2014/34/EU „ATEX“) – OPERATING MANUAL AND DECLARATION OF CONFORMITY	58
10.1	INTENDED USAGE	58
10.2	OPERATING MANUAL ATEX	58
10.2.1	General conditions	58
10.2.2	Installation	58
10.2.3	Operating	58
10.2.4	Failures	59
10.2.5	Maintenance and repair	59
10.3	ATEX CONFORMITY	59
10.3.1	Operating conditions	59
10.3.2	Labels	59
10.3.3	Specific conditions	60
10.3.4	Declaration of conformity	60
11	TRANSPORT / STORAGE / PACKAGING	62
12	REVISION INDEX	63

2 VS18/VS26-SYSTEM OVERVIEW

24V DC or 115V AC Multipole

Integrated Fieldbus

Field expandable with single add-on stations

Dual spool technology

VS18G/VS26G Glandless spool and sleeve
for long life

VS18S/VS26S Softseal spool
for high flow

Wide range of accessories

UL and ATEX

Universal PNP/NPN 24V DC Multipole

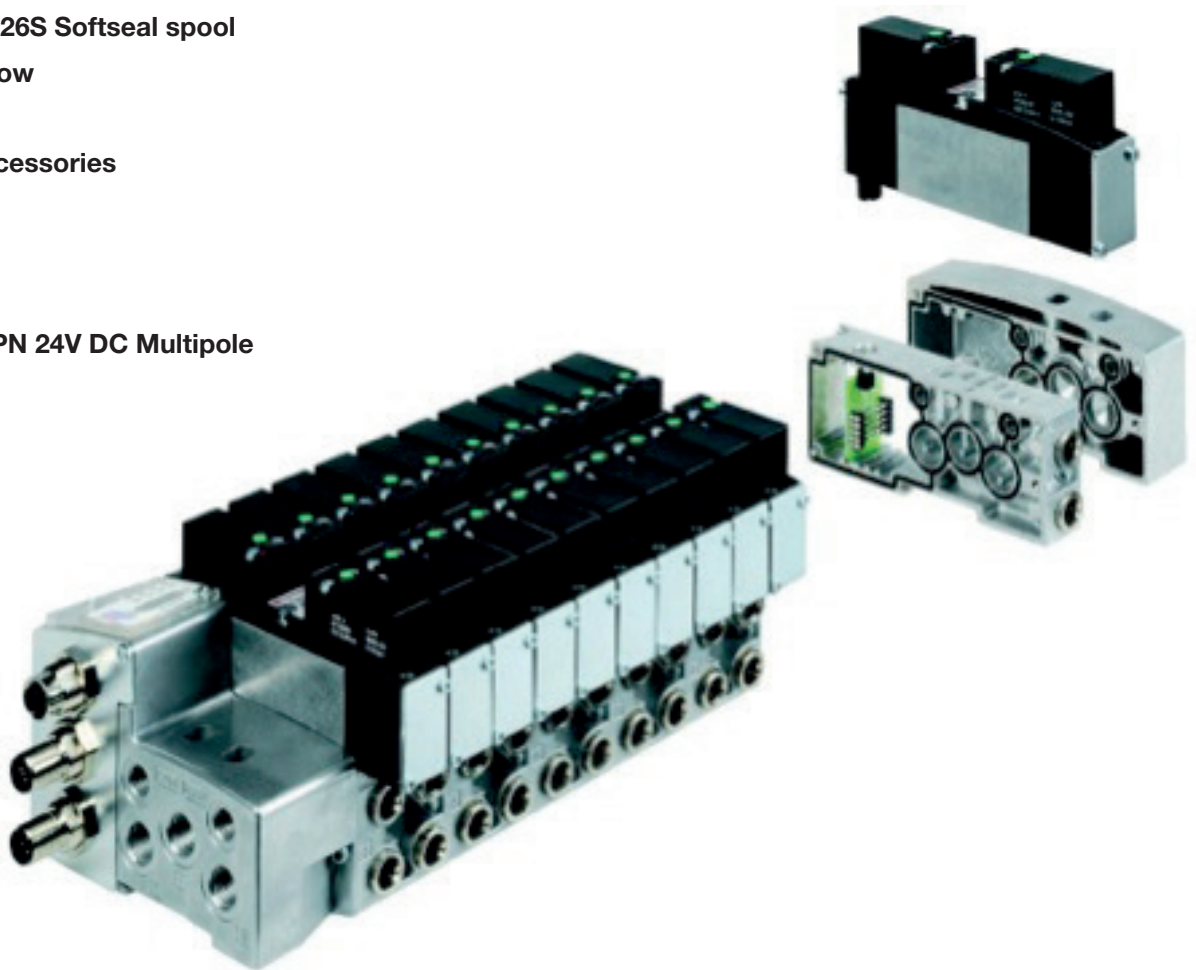

Please find ordering information of all components in the data sheets 5.1.250 (VS18) and 5.1.350 (VS26).

3 SAFETY, WARNING

These products are intended for use in industrial compressed air or hydraulic systems only. Do not use these products where pressures and temperatures can exceed those listed under 'Technical Data'.

Before using these products with fluids other than those specified, for non-industrial applications, life-support systems, or other applications not within published specifications, consult IMI Precision Engineering. Through misuse, age, or malfunction, components used in fluid power systems can fail in various modes. The system designer is warned to consider the failure modes of all component parts used in fluid power systems and to provide adequate safeguards to prevent personal injury or damage to equipment in the event of such failure.

System designers must provide a warning to end users in the system instructional manual if protection against a failure mode cannot be adequately provided. System designers and end users are cautioned to review specific warnings found in instruction sheets packed and shipped with these products.

Specific warnings:

- Check if classification of the valve island and marking on the item of equipment are able for case of operation.
- Check technical data, such as operating pressure, voltage level, current type and temperature, on the product label or in the data sheets for compliance with the existing operating conditions.
- After removing the packaging, make sure that no contamination enter into the system.
- Check before the installation of the system that no contamination exists in the piping and valve island.
- Check during installation of the system that gaskets will not become damaged.
- Please consider the information of this operating manual as well as the use conditions and permissible data, which are on the product labels.
- Adapt to the general rules of technology when selecting and using an item of equipment.
- Take measures to avoid unintentional or improper activation.
- Prior to the first electrical operation, ensure no danger would result from the medium exhausting from any open ports.
- Consider in case of pressurised systems that lines, valves and other components should not be removed.
- **ATTENTION:** There is some risk of injury! The surface of pilot valves could become very warm in continuous operation.
- **ATTENTION:** Valves with NO function (normally open) are open without pilot pressure. During commissioning, protection against exhausted medium has to be provided.
- Leak and strength tests on open and closed valves are admissible until max. 1.5 times the max. operating pressure. It is not allowed to operate the valve during these tests.
- Never use the valve island as lever arm or a step for climbing.
- Protect the valve island from falling objects.
- Any fitting position of the valve island is permissible but valves with indicating lights up is preferred.
- To avoid damaging the product, please make sure that the maximum torque values are not exceeded (see section 5.1.2).
- Avoid short-circuits and breaks by not deviating from the standard use of connector cables and cords.
- Order spare parts with the part number indicated on the product labels. (See section 5.2.2 and/or data sheets 5.1.250 (VS18) resp. 5.1.350 (VS26)).
- Do not load the system by bending or torsion.
- **IMPORTANT:** Power must be removed from the system while assembling and disassembling electrical connectors, plugs and cables, valves, sandwich plates and blanking plates.
- Install and use only complete configured and connected valve islands.
- VS18/VS26 Fieldbus valve islands contain electronic devices, which could be damaged through electrostatic discharge. Therefore electrostatic precautions must be taken. Specifically, the person assembling or configuring the valve island must be connected to an earth ground.
- Please refer to section 4.4.3 for information on power supply and earth ground connection of Multipole and Fieldbus valve islands.
- Use this booklet or the instruction sheets packed with the product for assembling and installation.

4 TECHNICAL DATA

For more information, please refer to data sheets 5.1.250 (VS18) and 5.1.350 (VS26).

4.1 SPECIFICATION

4.1.1 Ambient temperature

-15°C ... +50°C

(Consult our technical service for use below +2°C.)

4.1.2 Medium temperature

-5°C ... +50°C

4.1.3 Medium

The valves of these series are intended for use with compressed air only.

The valves must be operated within the pressure range specified in the data sheets 5.1.250 (VS18) and 5.1.350 (VS26).

4.1.4 Air quality

The valves are designed for filtered (40µm), lubricated or non-lubricated compressed air. (Please find details on oils in section 5.2.1.) If the air supply is lubricated, then lubrication must be supplied for the life of the product.

4.2 MATERIALS

Valve body / sub-bases:	Die-cast aluminium
Glandless spool&sleeve (VS**G):	Aluminium, hard anodised, teflon coated
Softseal spool (VS**S):	Aluminium with HNBR seals
Plastic parts:	POM, PA, PPA
Mounting sheets / screws:	steel, zinc coated
Springs:	stainless steel
Seals:	NBR
Sandwich plates:	Aluminium bar material, PA
Electrical contacts:	brass, tin/gold coated
PCB:	Glasepoxy

4.3 PNEUMATIC

4.3.1 Response times VS valves

The response measurements are taken according to ISO 12238 standard.

Glandless valves VS**G	VS18		VS26	
	Response time ON (ms)	Response time OFF (ms)	Response time ON (ms)	Response time OFF (ms)
5/2 Sol/Spring	18	54	24	58
5/2 Sol/Sol	18	18	20	20
5/2 Sol (priority side 14)/Sol	14*1)	21*2)	14*1)	21*2)
5/3 APB Sol/Sol	24	37	26	52
5/3 COE Sol/Sol	25	49	28	52
Softseal valves VS**S	VS18		VS26	
	Response time ON (ms)	Response time OFF (ms)	Response time ON (ms)	Response time OFF (ms)
2x2/2 NC Sol/Sol	24	21	29	29
2x2/2 NO Sol/Sol	24	21	29	29
2x2/2 NO/NC Sol/Sol	24	21	29	29
2x3/2 NC Sol/Sol	20	22	32	25
2x3/2 NO Sol/Sol	20	22	32	25
2x3/2 NO/NC Sol/Sol	20	22	32	25
5/2 Sol/Spring	16	42	18	46
5/2 Sol/Sol	14	14	14	14
5/3 APB Sol/Sol	18	40	20	55
5/3 COE Sol/Sol	18	40	19	55

*1) ON side 14

*2) ON side 12

APB = All ports blocked

COE = Centre open exhaust

NC = Normally closed

NO = Normally open

4.3.2 Flow

The flow values are measured at 6 bar inlet pressure and with a pressure drop of 1 bar.

Glandless valves VS**G	VS18			VS26		
	QN (L/min)	Kv (m³/h)	Cv (US Gal/min)	QN (L/min)	Kv (m³/h)	Cv (US Gal/min)
5/2 Sol/Spring	550	0.48	0.56	1'000	0.87	1.02
5/2 Sol/Sol	550	0.48	0.56	1'000	0.87	1.02
5/2 Sol (priority side 14) /Sol	550	0.48	0.56	1'000	0.87	1.02
5/3 APB Sol/Sol	550	0.48	0.56	1'000	0.87	1.02
5/3 COE Sol/Sol	550	0.48	0.56	1'000	0.87	1.02
Softseal valves VS**S	VS18			VS26		
	QN (L/min)	Kv (m³/h)	Cv (US Gal/min)	QN (L/min)	Kv (m³/h)	Cv (US Gal/min)
2x2/2 NC Sol/Sol	550	0.46	0.56	1'150	1.00	1.17
2x2/2 NO Sol/Sol	550	0.46	0.56	1'150	1.00	1.17
2x2/2 NO/NC Sol/Sol	550	0.46	0.56	1'150	1.00	1.17
2x3/2 NC Sol/Sol	600	0.52	0.61	1'250	1.09	1.27
2x3/2 NO Sol/Sol	600	0.52	0.61	1'250	1.09	1.27
2x3/2 NO/NC Sol/Sol	600	0.52	0.61	1'250	1.09	1.27
5/2 Sol/Spring	650	0.57	0.66	1'350	1.18	1.37
5/2 Sol/Sol	650	0.57	0.66	1'350	1.18	1.37
5/3 APB Sol/Sol	650	0.57	0.66	1'350	1.18	1.37
5/3 COE Sol/Sol	650	0.57	0.66	1'350	1.18	1.37

APB = All ports blocked
 COE = Centre open exhaust
 NC = Normally closed
 NO = Normally open

4.3.3 Maximum cycling rate

In practice the cycling rate should be lower than 300 c.p.m. (<5 Hz). The valves should be switched above 90% (working port) and below 10% (exhausting port) of the supply pressure.

4.3.4 Minimum impulse on bistable valves

The minimum impulse length on 5/2 way bistable valves should correspond at least twice to the response time (see section 4.3.1).

4.3.5 Important information for 2x2/2 valves

All 2x2/2 functions (NC, NO or NO/NC) have **port 1 not connected** in neither end position to port 2 or 4. Port 1 is not necessary (except internal pilot air). Supply of compressed air or vacuum must be feeded to port 3 or 5.

Pay attention to this when configuring the valve island (blanking off canals 3 and 5 in base) !!

4.4 ELECTRICAL

4.4.1 Voltage tolerances

Voltage	Voltage tolerances
24 V d.c.	+/-10%
115 V a.c.	-10%/+15%

4.4.2 Required performance of power supply unit

The required performance can be calculated from the maximum number of energized solenoids at the same time. In case of a Fieldbus valve island the consumption of power of the electronic has to be considered (see section 8).

4.4.3 Power supply and precautions

All VS18/ VS26 24V DC products are designed to be used with a protective extra low voltage (PELV) power supply (UL Class 2 Supply only).

All VS18/VS26 115V AC products correspond to the protection class I. Connection of the protective earth (PE) ground is required.

4.5 COMPLIANCE AND APPROVALS

The VS18/VS26 products are tested and compliant:

4.5.1 CE marking



Degrees of protection provided by enclosures (IP code):
EN 60529:91+A1:00 (IEC 60529:89 + A1:99)

Low-voltage switchgear and controlgear:
EN 60947-5-1: 97+A1:00+A2:00+A12:00 - Control circuit devices and switching elements
EN 60947-1: 99+A1:00+A2:01 - Electromechanical control circuit devices

Electromagnetic compatibility (EMC directive 89/336/EEC):
EN 61000-6-2: 01 - Immunity for industrial environments
EN 61000-6-4: 01 - Emission standard for industrial environments

Vibrations- and shock test:
DIN EN 60 068-2-6 - Vibration resistance (Test Fc: Vibration (sinusoidal))
DIN EN 60 068-2-27 (30g) - Shock resistance (Test Ea and guidance: Shock)

4.5.2 ATEX (Directive 2014/34/EU) for 24V DC only



EN 60079-0:2012 - Explosive atmospheres - Part 0: Equipment – General requirements
EN 60079-15:2010 -Explosive atmospheres - Part 15: Equipment protection by type of protection “n”
EN 60079-31:2014 -Explosive atmospheres - Part 31: Equipment dust ignition protection by enclosure “t”

For more information please refer to section 10.

4.5.3 ISO standard

ISO 15407-2 (size 26mm and 18mm)

4.5.4 Fieldbus standards

IMI Norgren **Profibus DP** Fieldbus systems conform to DIN 19245 part 3.

IMI Norgren **DeviceNet** systems conform to DeviceNet specification volume 1 release 2 and the Pneumatic Valve Device Profile.

IMI Norgren **CANopen** Fieldbus systems conform to CANopen communication profile CiA DS-301 V4.0.

IMI Norgren **Interbus-S** Fieldbus systems conform to DIN 19258.

IMI Norgren **AS-Interface** Fieldbus systems conform to AS-I V2.11 specification.

For detailed information on Fieldbus protocols please refer to section 8.

4.5.5 CNOMO standard

The M23 19-pin connector fulfils CNOMO standard E03.62.530.N.

For more information on this standard please refer to the CNOMO website www.cnomo.com.

For more information on the M23 19-pin connector please refer to section 7.4.

4.5.6 DIN standard

Colour code of D-Sub connectors according DIN 47100

4.5.7 UL approval

Investigated to UL 429 for 24 V d.c. electrically operated valves.



5 INSTALLATION AND MAINTENANCE MECHANICAL

5.1 INSTALLATION

5.1.1 Tools

VS18:

- Hexagon wrench key 2mm
- Hexagon wrench key 2.5mm
- Socket screw key X10
- Philips screwdriver size 1
- Screwdriver size 1

VS26:

- Hexagon wrench key 3mm
- Socket screw key X10
- Philips screwdriver size 1
- Screwdriver size 1

5.1.2 Tightening torque

To avoid damaging the product, please make sure that the maximum torque values are not exceeded. The maximum torques are specified in the particular installation instructions.

Valve mounting screws

The valve mounting screws are pressurised. To prevent leakage through the mounting screws, screws with blue coated thread are used. The specified torques for the blue coated screws reduce to standard values after first use of the screws. These screws should not be used more than five times, as good sealing performance can then not be guaranteed.

5.1.3 Port identification

On all end plates and modular sub-bases each port is marked as follows:

Function	Port/Identification
Main/internal pilot air supply	1
Exhaust	3 + 5
Outlet	2 + 4
External pilot air supply (if used)	12/14
Collected exhaust of pilot valves	82/84

Note:

Never plug port 82/84. Plugging this port will cause valves to malfunction.

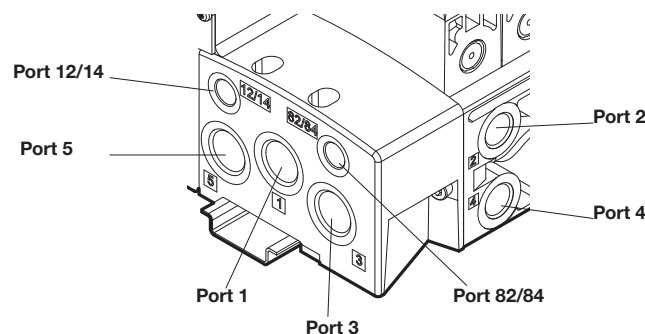

5.1.4 Assembly of VS18/VS26 valve islands

Tools:

- VS18: Hexagon wrench key 2.5mm
- Philips screwdriver size 1
- VS26: Hexagon wrench key 3mm
- Philips screwdriver size 1

To assemble a complete valve island, make sure you have ordered all necessary components and the required tools are available.

1. First bolt all modular sub-bases together. Ensure sub-bases are properly aligned and the gasket is fitted between the sub-bases. Then tighten the mounting screws (two per modular sub-base) with the specified torque. If you are using a power screwdriver, consider the maximum speed allowed. For multi pressure applications, please refer to section 5.1.7.

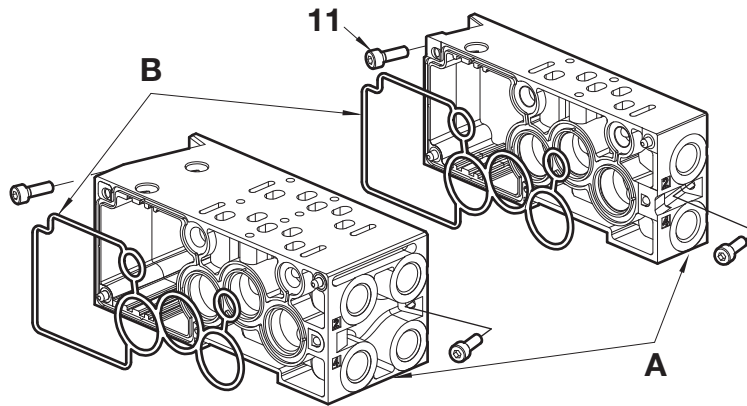

Screw	Type (thread)	Valve size	Tightening torque in Nm	Tightening torque in lbs	Max. screw driver speed in r.p.m.
11	M3x10	VS18	0.8 – 0.9	7.08 – 7.96	1100
11	M4x12	VS26	1.0 – 1.1	8.85 – 9.73	1100

Note:

When ordering an even number of stations, please ensure the valve island contains a maximum of two single station modular sub-bases. E.g.: You order an 8-station Multipole valve island with an 8-station main PCB. The valve island must have at least three double station modular sub-bases and must have no more than two single station modular sub-bases.

When ordering an odd number of stations, the single station modular sub-base should be at the right end of the valve island. In addition, you can use two additional single station modular sub-bases, for a total of three.

2. Mount the left and right end plate to the modular sub-base. Ensure end plates are properly aligned and the end plate gasket is fitted. Then tighten the mounting screws (two per end plate) with the specified torque. If you are using a power screwdriver, consider the maximum speed allowed.

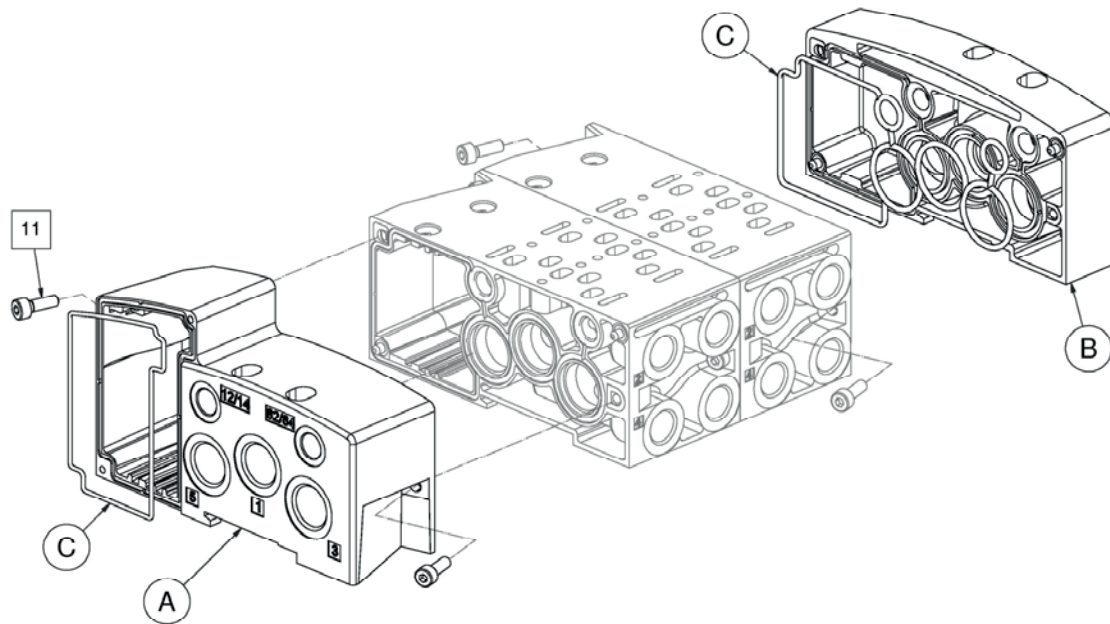

Screw	Type (thread)	Valve size	Tightening torque in Nm	Tightening torque in lbs	Max. screw driver speed in r.p.m.
11	M3x10	VS18	0.8 – 0.9	7.08 – 7.96	1100
11	M4x12	VS26	1.0 – 1.1	8.85 – 9.73	1100

3. Having assembled the base of the valve island, proceed with the electronic components. For these instructions please refer to following sections:

[7.2.1 D-Sub assembly / Installation of PCB](#)

[7.3.1 NPTF1" conduit entry with terminals assembly / Installation of PCB](#)

[7.4.1 M23 assembly / Installation of PCB](#)

[8.1.3 Fieldbus assembly / Installation of PCBs \(excluding AS-Interface\)](#)

[8.1.4 AS-Interface assembly / Installation of PCBs](#)

4. Lastly, mount the valves, sandwich plates, blanking plates and/or intermediate supply/exhaust modules.

Valves:

1. Ensure valve body gasket is fitted on the bottom of the valve. Place valve onto the modular sub-base aligned to the interface. Use plug-in connection as positioning point.
2. VS26 only: Orientate straight flange of the U-washers towards the outer edge of the valve.
3. Tighten the valve mounting screws (two per valve) with the specified torque. If you are using a power screwdriver, consider the maximum speed allowed.

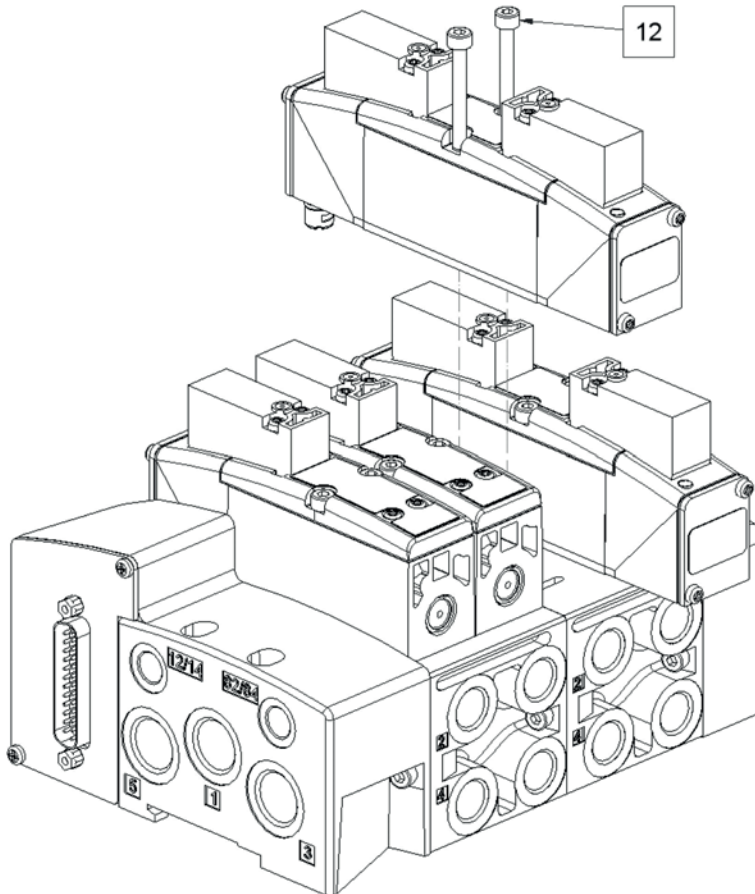

Screw	Type (thread)	Valve size	Tightening torque in Nm	Tightening torque in lbs	Max. screw driver speed in r.p.m.
12	M3 x 40	VS18	0.8 - 0.9	9.73 - 13.27	1100
12	M4 x43	VS26	1.2 - 1.6	10.62 - 14.16	1100

Blanking plate and/or intermediate supply/exhaust module (ISEM):

1. Ensure gasket is fitted on the bottom of the blanking plate or ISEM. Place blanking plate or ISEM onto the modular sub-base aligned to the interface.
2. Tighten mounting screws (two per blanking plate/ISEM) with the specified torque. If you are using a power screwdriver consider the maximum speed allowed.

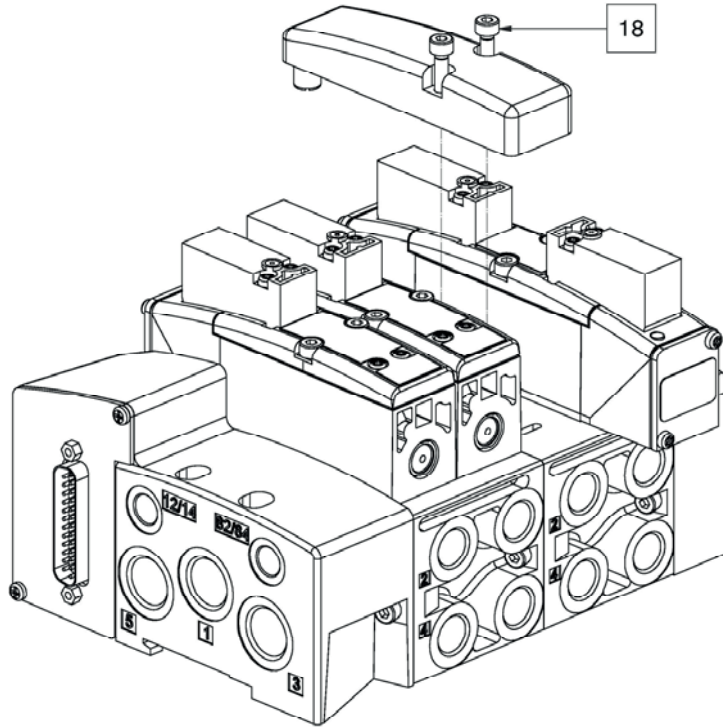

Screw	Type (thread)	Valve size	Tightening torque in Nm	Tightening torque in lbs	Max. screw driver speed in r.p.m.
18	M3 x 14	VS18	0.8 – 0.9	7.08 – 7.96	1100
18	M4 x 16	VS26	1.0 – 1.1	8.85 – 9.73	1100
Screw type used with ISEM:					
	M3 x 22	VS18	0.8 – 0.9	7.08 – 7.96	1100
	M4 x 25	VS26	1.0 – 1.1	8.85 – 9.73	1100

Sandwich plates: Please refer to section 5.1.10

5. Having assembled the complete valve island, it is possible to mount it on a DIN-rail. For instructions please refer to section 5.1.8.

5.1.5 Valve identification labels



When purchasing assembled valve islands from IMI Precision Engineering, valve identification labels are included. These labels are intended for the top of the pilot valves and provide sufficient space for text appropriate to your application.

Spare labels can also be ordered at IMI Precision Engineering as a set of 10 pieces. Order number for VS18 as well as VS26 is VS2672905-KG00.

The labels are AVERY standard labels (no. L6008) which can be ordered as DIN A4 sheets (21 x 29.7 cm) by your local representative of AVERY/Zweckform.

5.1.6 Internal/external pilot air supply

The position of the gasket between valve body and pilot valve defines and indicates pilot air supply. Conversion between internal and external pilot supply occurs by flipping the red gasket.

Internal pilot air supply (fig. 1): from port 1
External pilot air supply (fig. 2): from port 12/14

In any case pilot exhaust air is collected and exhausted via port 82/84.

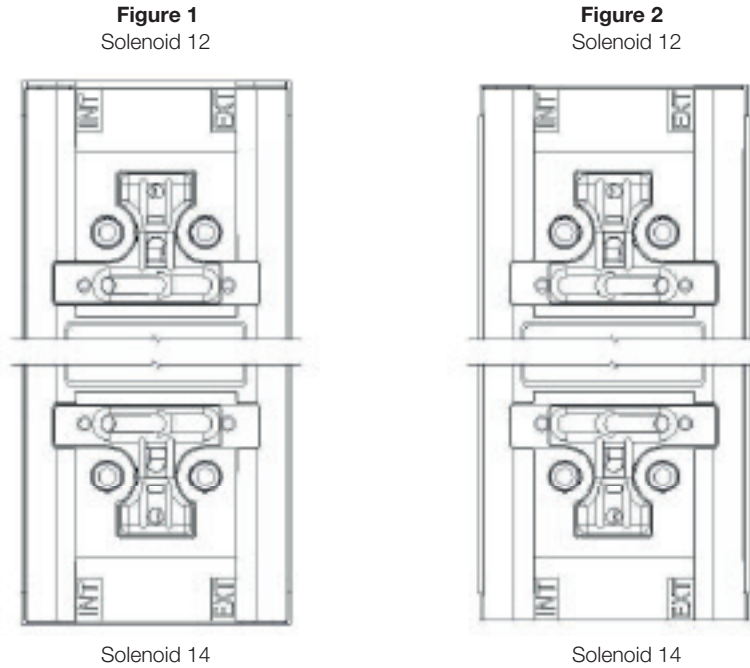

Such conversion in the field should occur only when minimum operating pressure is not available at port 1. In these applications, the minimum operating pressure (or higher) is required at port 12/14 on the end plate.

Note:

After flipping the gasket, data on the valve label (symbol and part number) are no longer accurate. Furthermore, when changing valves or accessories (valve function, sandwich plate, etc.) on a valve island, the part number on the label will no longer correspond to the configuration. If you order the valve island based on the IMI Norgren part number, the original configuration will be delivered.

5.1.7 Multi pressure

Tools:

VS18: Hexagon wrench key 2.5mm
VS26: Hexagon wrench key 3mm

By assembling blanking discs in ports 1, 3 and/or 5 as well as 12/14 you have the possibility to porting different pressures.

1. Install blanking discs depending on required pressure isolation requirements during the assembly of the modular sub-bases.
2. Generate pressure supply by connecting left and right end plate. Additionally, you have the possibility to mount an intermediate supply/exhaust module on a valve station.

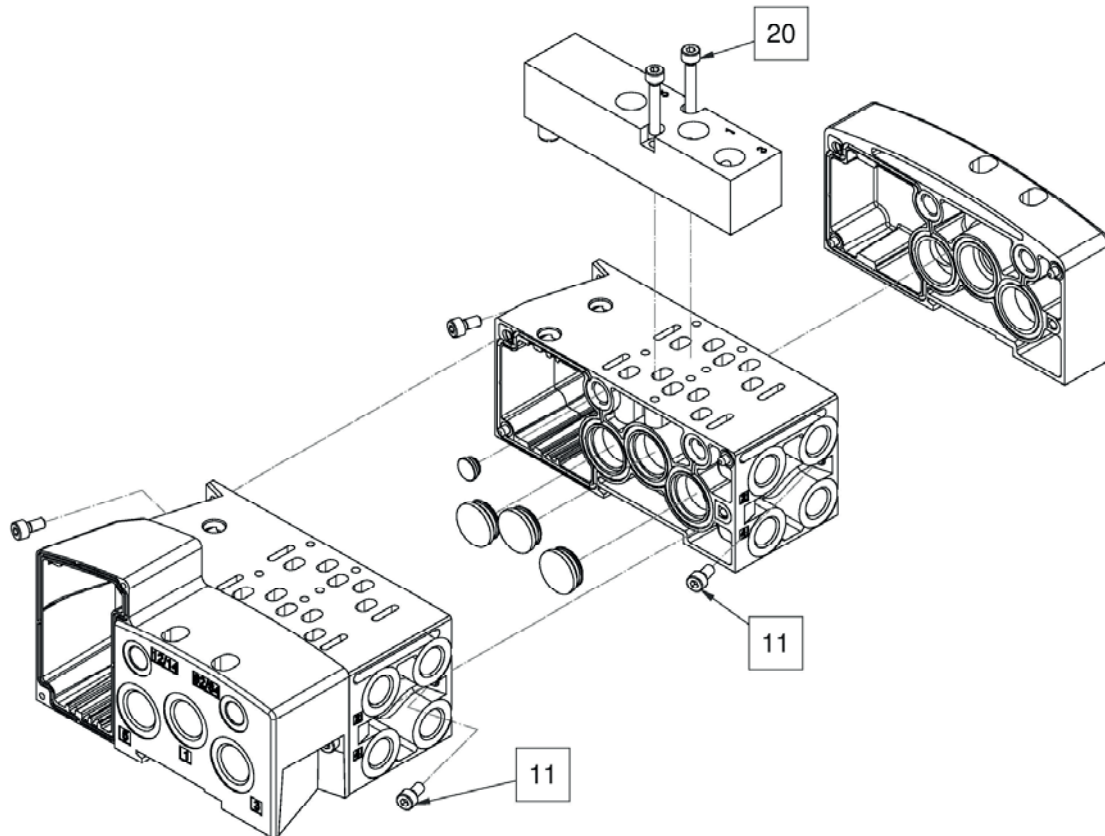

Screw	Type (thread)	Valve size	Tightening torque in Nm	Tightening torque in lbs	Max. screw driver speed in r.p.m.
11	M3 x 10	VS18	0.8 – 0.9	7.08 – 7.96	1100
11	M4 x 12	VS26	1.0 – 1.1	8.85 – 9.73	1100
20	M3 x 22	VS18	0.8 – 0.9	7.08 – 7.96	1100
20	M4 x 25	VS26	1.0 – 1.1	8.85 – 9.73	1100

5.1.8 DIN-rail assembly

Tool:

VS18/VS26: Hexagon wrench key 3mm

1. Insert screws on the left and right end plates and position below the mounting nuts. (Screws and mounting nuts are included in the DIN-rail mounting kit.) Tighten screws two revolutions in the mounting nuts.
2. Place the valve island on the DIN-rail. Orientate straight flange of the mounting nuts towards the DIN-rail.
3. Push the valve island on the DIN-rail and tighten screws with the specified torque. Check the fit of the valve island.

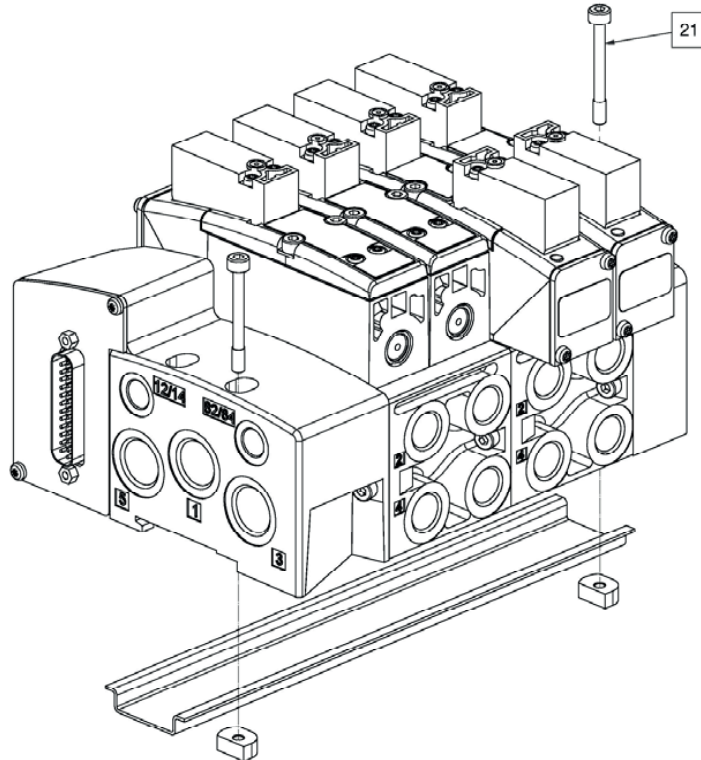

Screw	Type (thread)	Valve size	Tightening torque in Nm	Tightening torque in lbs	Max. screw driver speed in r.p.m.
21	M4 x 36	VS18/VS26	1.0 – 1.1	8.85 – 9.73	1100

5.1.9 Installation instruction in case of raised vibrations

In case of vibrations of about 5g (at 60 Hz to 150 Hz) it is strongly recommended to mount VS26 valve islands with more than 10 valve stations that main vibration load is in x-axis or alternatively in y-axis

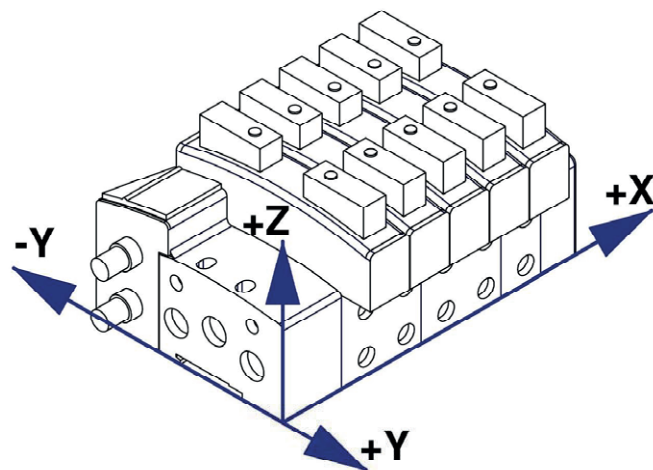

5.1.10 Sandwich plates

Tools:

VS18: Hexagon wrench keys 2mm and 2.5mm
VS26: Hexagon wrench key 3mm

VS18 only:

1. The valve mounting screws are pressurized. As the valve mounting holes on the VS18 sandwich plates go through the sandwich plate, this leads to leakage around the mounting screws. Therefore the existing valve mounting screws have to be replaced with the enclosed screws, which have a blue coated thread.
2. Loosen existing valve mounting screws (two per valve) by turning counter-clockwise and remove valve vertical to the top.
3. Replace the existing valve mounting screws with the blue coated screws. (Coated valve mounting screws are enclosed with the sandwich plates.)

VS18 & VS26

4. Ensure gasket is fitted on the bottom of the sandwich plate. Mount sandwich plate onto the sub-base aligned to the interface. Use plug-in connection as positioning point. Tighten mounting screws (two per sandwich plate) with the specified torque. If you are using a power screwdriver consider the maximum speed allowed.
5. Ensure valve body gasket is fitted on the bottom of the valve. Place valve onto the sandwich plate aligned to the interface. Use plug-in connection as positioning point.
- 5.1. VS26 only: Orientate straight flange of the U-washers towards the outer edge of the valve.
6. Tighten valve mounting screws (two per valve) with the specified torque. If you are using a power screwdriver consider the maximum speed allowed.

Note:

If threads of the sandwich plate are damaged by Allen wrench, this might affect the sealing performance.

The replacement of the valve mounting screws is essential when using all sandwich plates in the VS18 range.

When changing valves or accessories (valve function, sandwich plate, etc.) on a valve island, the part number on the label will no longer correspond to the configuration. If you order the valve island based on the IMI Norgren part number, the original configuration will be delivered

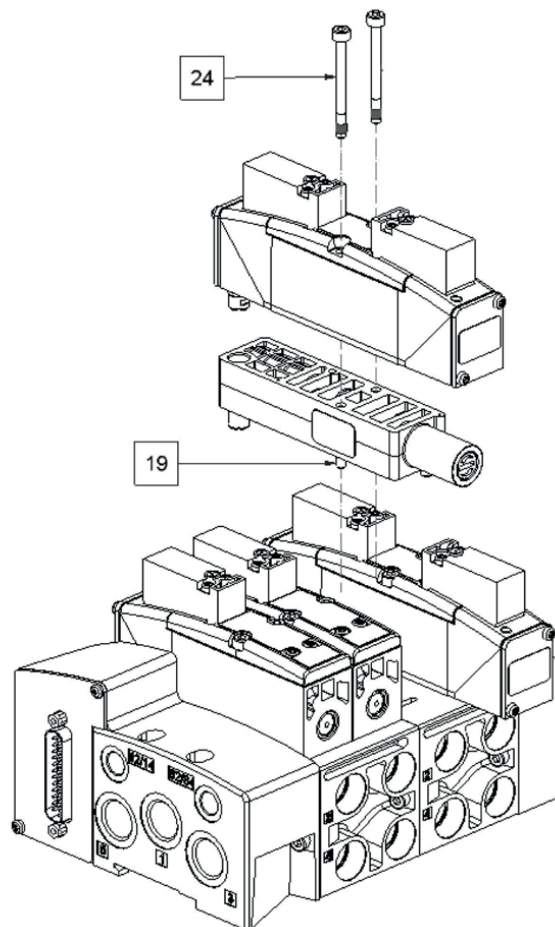

Screw	Type (thread)	Valve size	Tightening torque in Nm	Tightening torque in lbs	Max. screw driver speed in r.p.m.
24	M3 x 40	VS18	1.1 – 1.5	9.73 – 13.27	1100
24	M4 x 43	VS26	1.2 – 1.6	10.62 – 14.16	1100
19	M3 x 8	VS18	0.8 – 0.9	7.08 – 7.96	1100
19	M4 x 10	VS26	1.0 – 1.1	8.85 – 9.73	1100

Note: With all sandwich plate accessories will be used the same screw type.

5.1.11 Replacement of valves

Tools:

- VS18 Hexagon wrench key 2.5mm
- VS26 Hexagon wrench key 3mm

1. Loosen existing valve mounting screws (two per valve) by turning counter-clockwise and remove valve vertical to the top.
2. Ensure valve body gasket is fitted on the bottom of the new valve. Place new valve onto the modular sub-base aligned to the interface. Use plug-in connection as positioning point.
3. VS26 only: Orientate straight flange of the U-washers towards the outer edge of the valve.
4. Tighten valve mounting screws (two per valve) with the specified torque. If you are using a power screwdriver consider the maximum speed allowed.

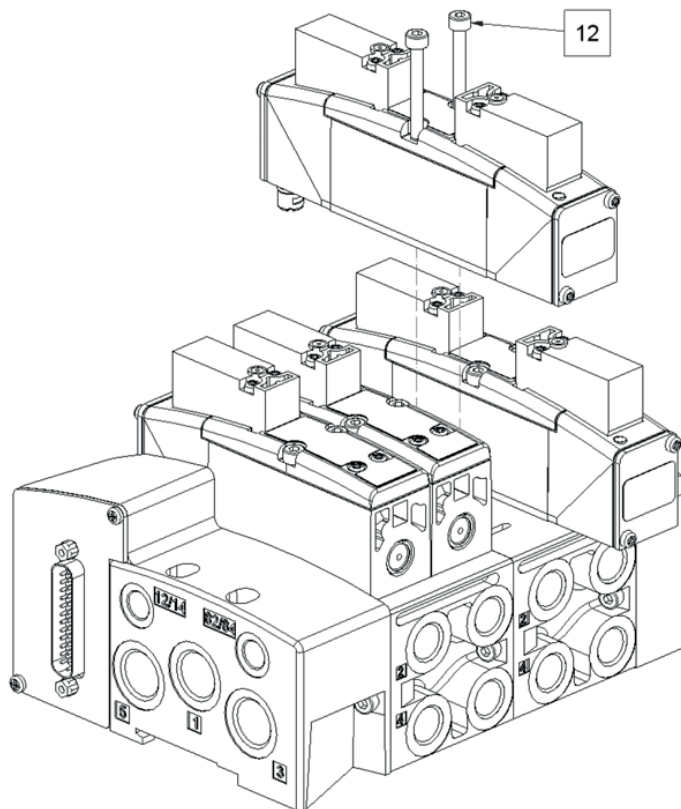

Screw	Type (thread)	Valve size	Tightening torque in Nm	Tightening torque in lbs	Max. screw driver speed in r.p.m.
12	M3 x 40	VS18	0.8 - 0.9	9.73 – 13.27	1100
12	M4 x 43	VS26	1.2 – 1.6	10.62 – 14.16	1100

Note:

To avoid failures and/or use of valves with not allowed specification, you have to make sure that the voltage of the new valve complies to the old one. When changing valves or accessories (valve function, sandwich plate, etc.) on a valve island, the part number on the label will no longer correspond to the configuration. If you order the valve island based on the IMI Norgren part number, the original configuration will be delivered.

5.1.12 Replacement of pilot valves

Tool:

VS18/VS26: Socket screw key X10

1. Loosen existing pilot valve screws (two per pilot valve) by turning counter-clockwise.
2. Important: Check and keep in mind the position of the gasket (A) between valve body and pilot valve (internal or external pilot air supply) to make sure placing the new gasket is set for the appropriate pilot type.
3. Remove pilot valve, V-ring (B) and gasket (A).
4. Place new V-ring (B) and new gasket (A). Consider now the position of the gasket (A) (internal or external pilot air supply).
5. Place new pilot valve. Important: Turn new thread moulded pilot valve screws (two per pilot valve) by hand in the existing threads for safe seizing to avoid damaging the existing thread. Tighten the screws then with the specified torque. Do not use a power screwdriver!

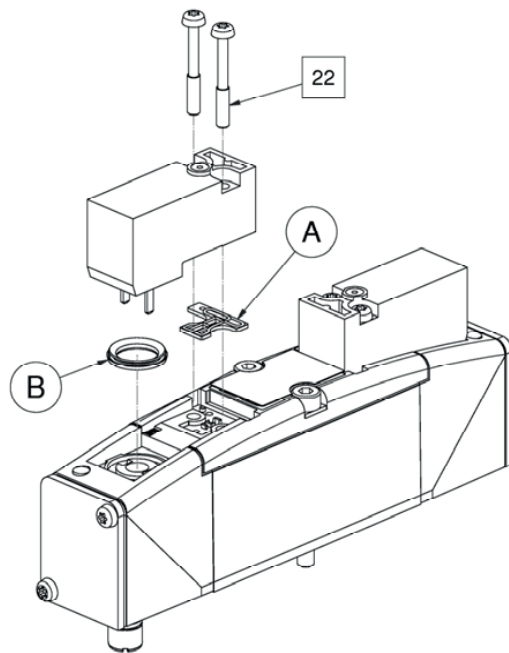

Screw	Type (thread)	Valve size	Tightening torque in Nm	Tightening torque in lbs
22	M3 x 24	VS18/VS26	0.9 – 1.0	7.96 – 8.85

Note:

To avoid failures and/or use of valves with not allowed specification, you have to make sure that the voltage of the new pilot valve complies to the old one.
When changing valves or accessories (valve function, sandwich plate, etc.) on a valve island, the part number on the label will no longer correspond to the configuration. If you order the valve island based on the IMI Norgren part number, the original configuration will be delivered.

The pilot valve set includes:

- 1 pilot valve
- 1 gasket
- 1 V-ring
- 2 pilot valve screws

For ordering information on pilot valves refer to section 5.2.2.

5.1.13 Manual override set-up kit

Tool:

VS18/VS26: Socket screw key X10

Use the manual override set-up kit to lock a non-locking manual override (excluding extended manual override) as follows:

1. Remove existing pilot valve screws by turning counter-clockwise.
2. Put the adapter (A) on the pilot valve and mount it with the socket screws which are included in the kit. Important: Turn thread moulded pilot valve screws (two per adapter) by hand in the existing threads for safe seizing to avoid damaging the existing thread. Tighten the screws then with the specified torque. Do not use a power screwdriver!
3. Put the key (B) on the adapter (A).
4. For operating the manual override kit, push and turn the key (B) clockwise.

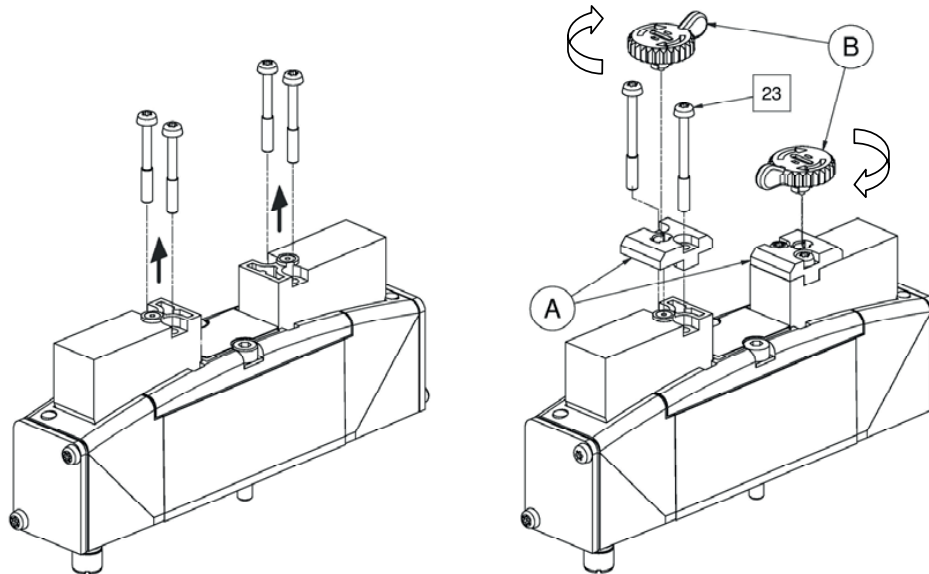

Screw	Type (thread)	Valve size	Tightening torque in Nm	Tightening torque in lbs
23	M3 x 29	VS18/VS26	0.9 – 1.0	7.96 – 8.85

Note:

The key is provided for commissioning of the valve island only. If the key is left on the valve in the operated position, the valve is switched on continually. When changing valves or accessories (valve function, sandwich plate, etc.) on a valve island, the part number on the label will no longer correspond to the configuration. If you order the valve island based on the IMI Norgren part number, the original configuration will be delivered.

The manual override set-up kit includes:

- 1 adapter
- 2 socket screws
- 1 key

5.1.14 Blanking plug for base connector hole

For some applications an actuation of hard-wired valves on VS base (eg. safety function) is required. The assembly of Mini ISO valves on VS sub-bases is possible due to the same pneumatical interface. In these cases, the base connector hole is open. The IP65 blanking plug protects PCB from dirt and humidity.

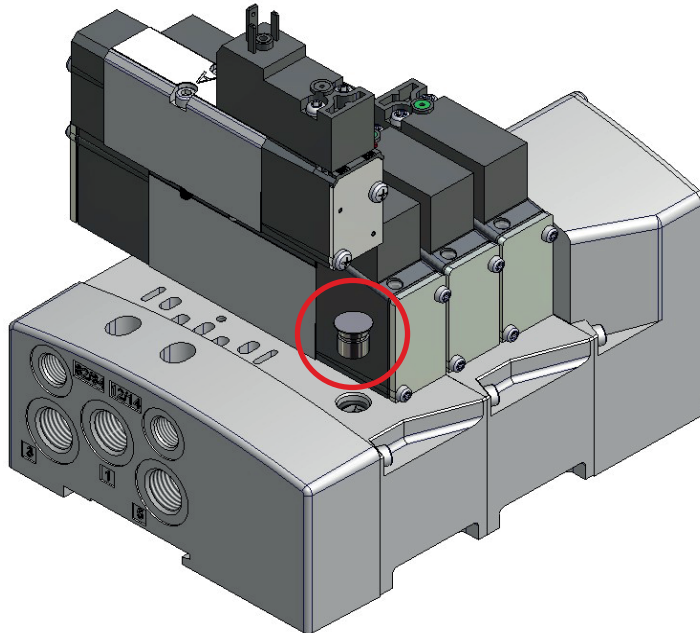

5.2 MAINTENANCE

5.2.1 Lubrication

VS18/VS26 valves are pre-lubricated for life on assembly, but where air line lubricants are required for pneumatic actuators or other driven devices, the following products are recommended:

- Klüber Airpress 32
- Castrol Hyspin AWS 32
- Mobil Gargoyle Arctic Oil (Light)
- Mobil DTE 24
- Mobil DTE Light Oil
- Shell Tellus 22
- Shell Tellus 37
- Smallman Crown 10

For low temperatures (+5°C until -15°C) the following oils are recommended:

- Klüber Airpress 16
- Mobil SHL 264
- Duckhams Zeroflo 32

Note:

- If the air supply is lubricated, then lubrication must be supplied for the life of the product.
- Please consider the compatibility of the oil you use with the materials of the valve island.

5.2.2 Spare parts

Pilot valves VS18/VS26:

Part no.	Description	Voltage	Manual override
VS2672930-KG00	Pilot valve including screws, gasket and V-ring	24V DC 1.2W	Push only
VS2672932-KG00	Pilot valve including screws, gasket and V-ring	24V DC 1.2W	Push & turn
VS2672934-KG00	Pilot valve including screws, gasket and V-ring	24V DC 1.2W	Extended, push only
VS2672931-KG00	Pilot valve including screws, gasket and V-ring	115V AC 1.5VA	Push only
VS2672933-KG00	Pilot valve including screws, gasket and V-ring	115V AC 1.5VA	Push & turn
VS2672935-KG00	Pilot valve including screws, gasket and V-ring	115V AC 1.5VA	Extended, push only

Spare parts for VS18/VS26 valves:

Part no.	Description
94.00759	Valve body gasket VS26
94.00907	Valve body gasket VS18
77.01153	Coated valve mounting screws VS26
77.01152	Coated valve mounting screws VS18
94.05010	Valve mounting screws VS18
94.00785	U-washers VS26

Spare parts for VS18/VS26 sub-bases and end plates:

Part no.	Description
77.31106	Hexagon socket screw M4x12 (VS26)
77.31055	Hexagon socket screw M3x10 (VS18)
94.00815	Gasket VS26
94.01015	Gasket VS18
94.00816	Connector-kit gasket on end plate VS18/VS26

6 SINGLE STATION SUB-BASE

6.1 GENERAL INFORMATION

VS18/VS26 offers single station sub-bases for valves located remotely from valve island.

Below listed connectors are available for the electrical connection to the VS18/VS26 single station sub-base. Please refer to the indicated section for detailed information on these.

- M12 connector Section 6.2
- NPTF1/2" conduit entry with flying leads Section 6.3

Please see information on assembly of valve and sandwich plates in section 5.1.4.

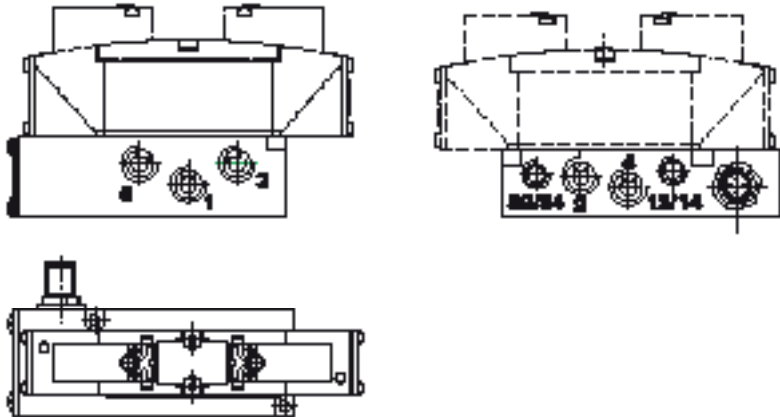

6.1.1 24V DC power supply

VS18/VS26 single station sub-base 24V DC versions are designed to be used with a protective extra low voltage (PELV) power supply (UL Class 2 Supply only). Therefore, the power supply used must meet the IEC standard 742/EN60742/VDE 0551 (PELV).

6.1.2 115V AC power supply

VS18/VS26 single station sub-base 115V AC versions correspond to the protection class I. Connection of the protective earth (PE) ground is required.

6.1.3 Max current load on valve connectors with 24V DC

$$I_{max} = 60mA * n$$

n = number of energized solenoids

6.1.4 Max current load on valve connectors with 115V AC

$$I_{max} = 13mA * n$$

n = number of energized solenoids

6.2 VARIANT WITH M12 CONNECTOR

The single station sub-base with M12 connector is available with G or NPTF pneumatic ports.

With the M12 connector, the power supply has to be 24V DC.

6.2.1 Pin assignment (acc. VDMA 24571)

Symbol	Pin no.	Function
	1	Not used
	2	Signal for solenoid 12
	3	Common for solenoid 12 and 14
	4	Signal for solenoid 14

Looking into node connectors

6.3 VARIANT WITH NPTF1/2" CONDUIT WITH FLYING LEADS

The single station sub-base with NPTF1/2" conduit with flying leads is available with G pneumatic ports only.

The power supply can be 24V DC or 115V AC. If you use 115V AC, connection of the protective earth (PE) ground is required.

6.3.1 Wiring information

Wire colour	Function
Green	Earth
Yellow	Signal for solenoid 12
Black	Common for solenoid 12 and 14
Red	Signal for solenoid 14



7 MULTIPOLE

7.1 GENERAL INFORMATION

VS18/VS26 Multipole valve islands are intended for direct connection to a control system output device. The system is designed for either PNP-switching (common negative anode) and NPN-switching (common positive anode).

VS18/VS26 Multipole valve islands consist of a minimum two valve stations. The maximum number of valve stations is 20 (40 solenoids). You have to consider the maximum number of possible valve stations of each Multipole connector. See section 9 for information of field expansion of the valve island.

Below listed connectors are available for the electrical connection to the VS18/VS26 Multipole valve islands. Please refer to the indicated section for detailed information on these.

- D-Sub 9-, 15-, 25- or 44-pin Section 7.2
- NPTF1" Conduit entry with terminals Section 7.3
- M23 19-pin connector Section 7.4

7.1.1 24V DC power supply

VS18/VS26 Multipole 24V DC versions are designed to be used with a protective extra low voltage (PELV) power supply (UL Class 2 Supply only). Therefore, the power supply used must meet the IEC standard 742/EN60742/VDE 0551 (PELV).

7.1.2 115V AC power supply

VS18/VS26 Multipole 115V AC versions correspond to the protection class I. Connection of the protective earth (PE) ground is required.

7.1.3 Max current load on valve connectors with 24V DC

$$I_{max} = 60mA * n$$

n = number of energized solenoids

7.1.4 Max current load on valve connectors with 115V AC

$$I_{max} = 13mA * n$$

n = number of energized solenoids

7.2 VARIANTS WITH D-SUB CONNECTORS

The D-Sub connector is available in many sizes:

D-Sub 9-pin	max. 4 valve stations (8 solenoids)
D-Sub 15-pin	max. 7 valve stations (14 solenoids)
D-Sub 25-pin	max. 12 valve stations (24 solenoids)
D-Sub 44-pin	min. 8 valve stations, max. 20 valve stations (40 solenoids) *1)

With all D-Sub connectors, the power supply has to be 24V DC.

*1) special D-Sub 44-pin cable with 42 assigned pins also available

7.2.1 D-Sub assembly / Installation of PCB

Tool:

VS18/VS26 Philips screwdriver size 1

1. Important: Make sure valves are not already mounted on the valve island, because the Multipole PCB (A) could become damaged during assembly.
2. Ensure connector-kit gasket is fitted on the left end plate.
3. Insert the Multipole PCB, which is fitted on the Multipole E-connector-kit (A), in the left groove of the left end plate and the modular sub-bases. Check to make sure the plug-in connection on the PCB is centred with the orifice to the valve interface.
4. Mount the Multipole E-connector-kit (A) with two mounting screws on the left end plate. Tighten the screws with the specified torque. If you are using a power screwdriver consider the maximum speed allowed.

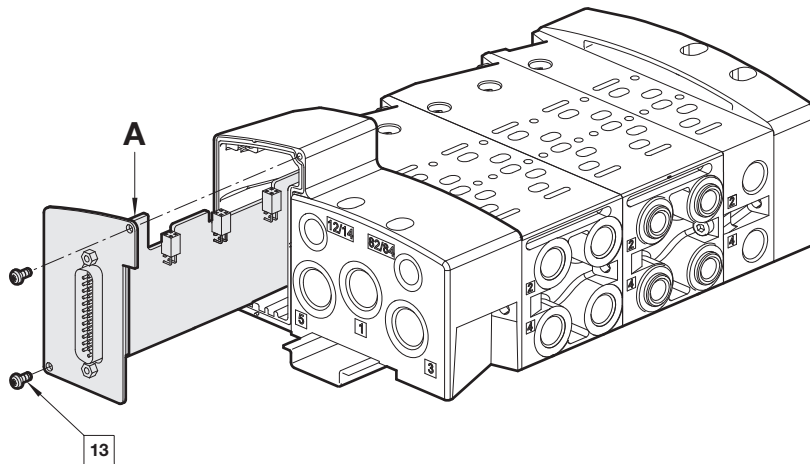

Screw	Type (thread)	Valve size	Tightening torque in Nm	Tightening torque in lbs	Max. screw driver speed in r.p.m.
13	M3 x 8	VS18/VS26	0.8 – 0.9	7.08 – 7.96	1100

7.2.2 Pin assignment

D-Sub 9-pin

Pin no.	Wire colour	Socket	Pilot	Station
1	white	Solenoid 1-a	14	1
2	brown	Solenoid 2-a	14	2
3	green	Solenoid 3-a	14	3
4	yellow	Solenoid 4-a	14	4
5	grey	Solenoid 1-b	12	1
6	pink	Solenoid 2-b	12	2
7	blue	Solenoid 3-b	12	3
8	red	Solenoid 4-b	12	4
9	black	Common	-	-

Colour code according to DIN 47100

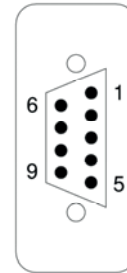

Looking into node connectors

D-Sub 15-pin

Pin no.	Wire colour	Socket	Pilot	Station
1	white	Solenoid 1-a	14	1
2	brown	Solenoid 2-a	14	2
3	green	Solenoid 3-a	14	3
4	yellow	Solenoid 4-a	14	4
5	grey	Solenoid 5-a	14	5
6	pink	Solenoid 6-a	14	6
7	blue	Solenoid 7-a	14	7
8	red	Solenoid 1-b	12	1
9	black	Solenoid 2-b	12	2
10	violet	Solenoid 3-b	12	3
11	grey/pink	Solenoid 4-b	12	4
12	red/blue	Solenoid 5-b	12	5
13	white/green	Solenoid 6-b	12	6
14	brown/green	Solenoid 7-b	12	7
15	white/yellow	Common	-	-

Colour code according to DIN 47100

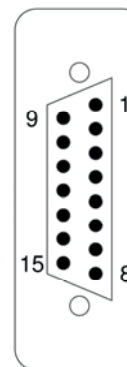

Looking into node connectors

D-Sub 25-pin

Pin no.	Wire colour	Socket	Pilot	Station
1	white	Solenoid 1-a	14	1
2	brown	Solenoid 2-a	14	2
3	green	Solenoid 3-a	14	3
4	yellow	Solenoid 4-a	14	4
5	grey	Solenoid 5-a	14	5
6	pink	Solenoid 6-a	14	6
7	blue	Solenoid 7-a	14	7
8	red	Solenoid 8-a	14	8
9	black	Solenoid 9-a	14	9
10	violet	Solenoid 10-a	14	10
11	grey/pink	Solenoid 11-a	14	11
12	red/blue	Solenoid 12-a	14	12
13	white/green	Common	-	-
14	brown/green	Solenoid 1-b	12	1
15	white/yellow	Solenoid 2-b	12	2
16	yellow/brown	Solenoid 3-b	12	3
17	white/grey	Solenoid 4-b	12	4
18	grey/brown	Solenoid 5-b	12	5
19	white/pink	Solenoid 6-b	12	6
20	pink/brown	Solenoid 7-b	12	7
21	white/blue	Solenoid 8-b	12	8
22	brown/blue	Solenoid 9-b	12	9
23	white/red	Solenoid 10-b	12	10
24	brown/red	Solenoid 11-b	12	11
25	white/black	Solenoid 12-b	12	12

Colour code according to DIN 47100

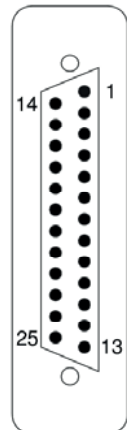

Looking into node connectors

D-Sub 44-pin

Pin no.	Wire colour	Socket	Pilot	Station
1	white	Solenoid 1-a	14	1
2	brown	Solenoid 2-a	14	2
3	green	Solenoid 3-a	14	3
4	yellow	Solenoid 4-a	14	4
5	grey	Solenoid 5-a	14	5
6	pink	Solenoid 6-a	14	6
7	blue	Solenoid 7-a	14	7
8	red	Solenoid 8-a	14	8
9	black	Solenoid 9-a	14	9
10	violet	Solenoid 10-a	14	10
11	grey/pink	Solenoid 11-a	14	11
12	red/blue	Solenoid 12-a	14	12
13	white/green	Solenoid 13-a	14	13
14	brown/green	Solenoid 14-a	14	14
15	white/yellow	Solenoid 15-a	14	15
16	yellow/brown	Solenoid 1-b	12	1
17	white/grey	Solenoid 2-b	12	2
18	grey/brown	Solenoid 3-b	12	3
19	white/pink	Solenoid 4-b	12	4
20	pink/brown	Solenoid 5-b	12	5
21	white/blue	Solenoid 6-b	12	6
22	brown/blue	Solenoid 7-b	12	7
23	white/red	Solenoid 8-b	12	8
24	brown/red	Solenoid 9-b	12	9
25	white/black	Solenoid 10-b	12	10
26	brown/black	Solenoid 11-b	12	11
27	grey/green	Solenoid 12-b	12	12
28	yellow/grey	Solenoid 13-b	12	13
29	pink/green	Solenoid 14-b	12	14
30	yellow/pink	Solenoid 15-b	12	15
31	green/blue	Solenoid 16-a	14	16
32	yellow/blue	Solenoid 16-b	12	16
33	-	not used	-	-
34	-	not used	-	-
35	-	not used	-	-
36	-	not used	-	-
37	-	not used	-	-
38	-	not used	-	-
39	-	not used	-	-
40	-	not used	-	-
41	-	not used	-	-
42	-	not used	-	-
43	blue/black 1)	Common	-	-
44	red/black 1)	Common	-	-

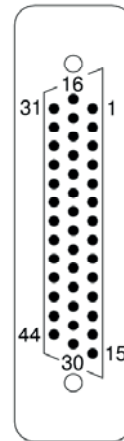

Looking into node connectors

Colour code according to DIN 47100

1) The IMI Norgren D-Sub 44-pin cables do not have 44 wires, but only 34 wires. Therefore, the wires associated with pins 1 through 32 are according to DIN 47100, wires 43 and 44 differ from the standard and are coloured in green/black and yellow/black.

7.3 VARIANT WITH NPTF1" CONDUIT ENTRY WITH TERMINALS

The NPTF1" conduit entry with terminals is composed of a body with a NPTF1" thread for use with flexible or fixed conduit. In this body exists a terminal block for connecting all necessary wires.

The NPTF1" conduit entry is valid for a valve island with maximum 12 valve stations (24 solenoids).

The power supply can be 24V DC or 115V AC. If you use 115V AC, connection of the protective earth (PE) ground is required.

7.3.1 NPTF1" conduit entry with terminals assembly / Installation of PCB

Tools:

VS18/VS26: Philips screwdriver size 1 and screwdriver size 1

1. Important: Make sure valves are not already mounted on the valve island, because the Multipole PCB (B) could become damaged during assembly.
2. Remove the terminal block (C) from the body (A) by loosening the two plastic screws as well as the two earth contact screws with serrated lock washers.

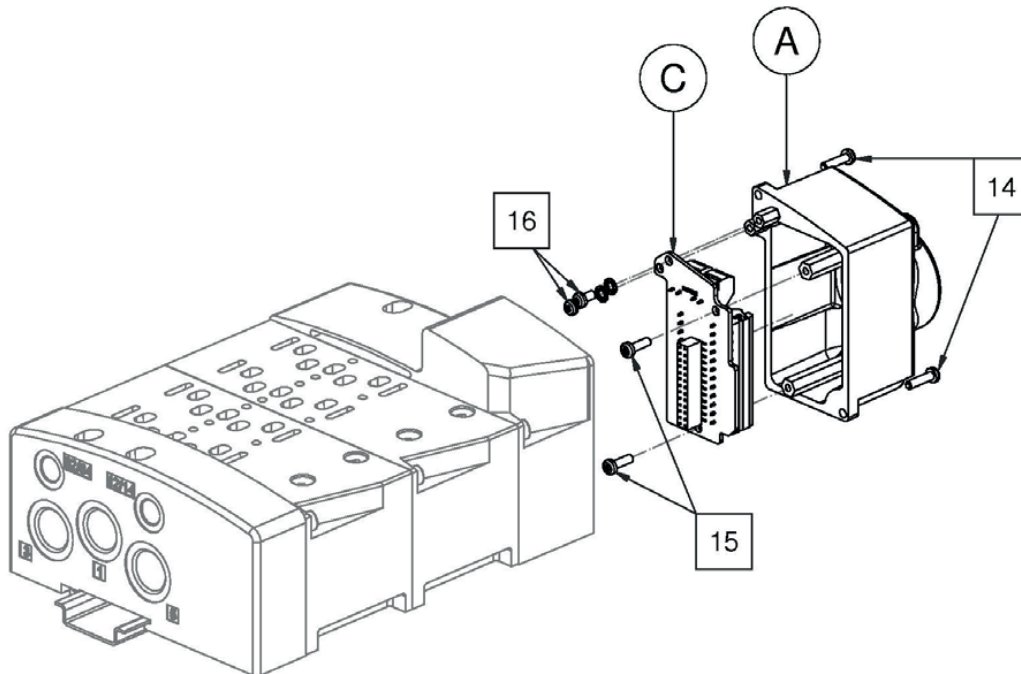

Screw	Type (thread)	Valve size	Tightening torque in Nm	Tightening torque in lbs	Max. screw driver speed in r.p.m.
14	M3 x 12	VS18/VS26	0.8 – 0.9	7.08 – 7.96	1100
15	M3 x 10	VS18/VS26	0.1	0.88	Tighten by hand!
16	M3 x 6	VS18/VS26	0.5	4.42	750 or tighten by hand!

3. Use the schematic in section 7.3.2 for wiring. Unlock corresponding square clamping on the terminal block by pushing the screwdriver on the diagonal trench. Insert one wire into the clamp. By removing the screwdriver, the wire is fixed. Repeat this step with each additional wire.
4. Important: Connect common wire (COM) and protective earth (PE) ground wire!
5. Remount the terminal block (C) with the two plastic screws (15) on the body (A). Turn plastic screws by hand in the existing threads and tighten then by hand. Note: Use of plastic screws is required because the minimum distance to the body (electrical safety) does not allow metal screws.
6. The two closed mounting holes are made for the earthing of the Multipole PCB (B). Mount the two screws (16) with the serrated lock washers. The serrated lock washers give a safe contact even if the screws oxidise. Tighten the screws with the specified torque. If you are using a power screwdriver consider the maximum speed allowed.
7. Insert the Multipole PCB (B) in the left groove of the left end plate and the modular sub-bases. Check to make sure the plug-in connection on the PCB is centred with the orifice to the valve interface.
8. Ensure connector-kit gasket is fitted on the left end plate.
9. Plug the terminal block (C) in the body (A) on the Multipole PCB (B).
10. Mount the body (A) with two mounting screws on the left end plate. Tighten the screws with the specified torque. If you are using a power screwdriver consider the maximum speed allowed.

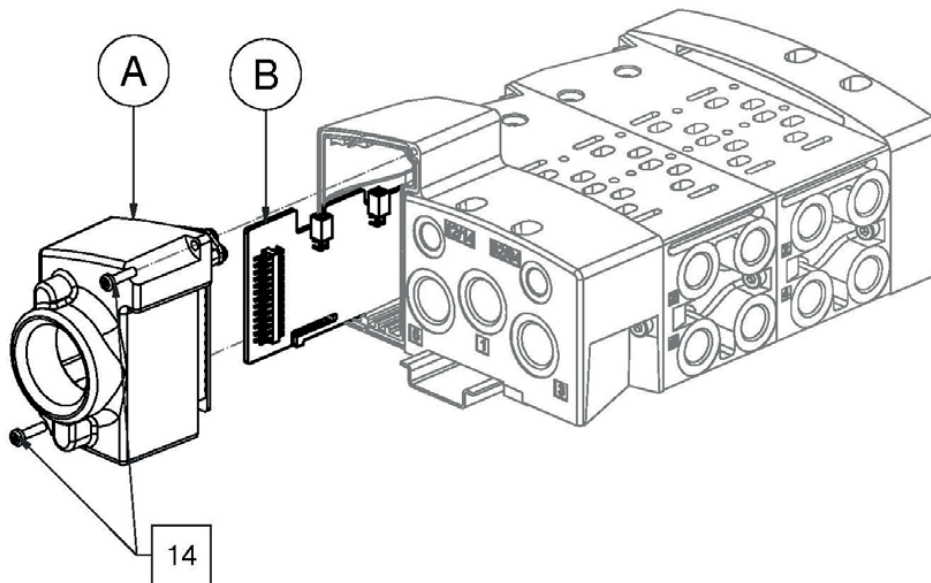

Screw	Type (thread)	Valve size	Tightening torque in Nm	Tightening torque in lbs	Max. screw driver speed in r.p.m.
14	M3x12	VS18/VS26	0.8 – 0.9	7.08 – 7.96	1100

7.3.2 Pin assignment

Clamp no.	Socket	Pilot	Station
Socket	Pilot	Station	1
C1	Solenoid 1-a	14	1
C2	Solenoid 2-a	14	2
C3	Solenoid 3-a	14	3
C4	Solenoid 4-a	14	4
C5	Solenoid 5-a	14	5
C6	Solenoid 6-a	14	6
C7	Solenoid 7-a	14	7
C8	Solenoid 8-a	14	8
C9	Solenoid 9-a	14	9
C10	Solenoid 10-a	14	10
C11	Solenoid 11-a	14	11
C12	Solenoid 12-a	14	12
C13	Solenoid 1-b	12	1
C14	Solenoid 2-b	12	2
C15	Solenoid 3-b	12	3
C16	Solenoid 4-b	12	4
C17	Solenoid 5-b	12	5
C18	Solenoid 6-b	12	6
C19	Solenoid 7-b	12	7
C20	Solenoid 8-b	12	8
C21	Solenoid 9-b	12	9
C22	Solenoid 10-b	12	10
C23	Solenoid 11-b	12	11
C24	Solenoid 12-b	12	12
C25	Common	-	-
C26	Common	-	-
C27	Earth	-	-
C28	Earth	-	-

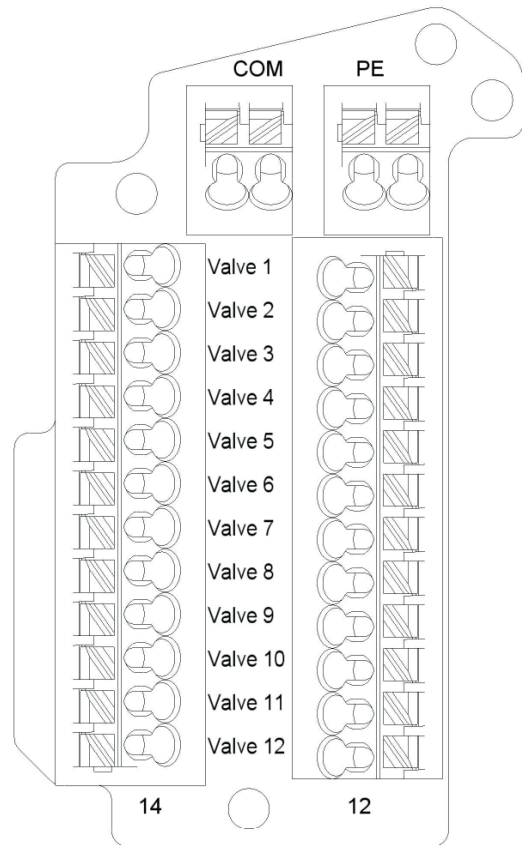

Maximum wire size = AWG18

7.4 VARIANT WITH M23 CONNECTOR

The M23 19-pin connector is valid for a valve island with maximum 8 valve stations (16 solenoids).

The power supply can be 24V DC or 115V AC. If you use 115V AC, connection of the protective earth (PE) ground is required.

The M23 19-pin connector fulfils CNOMO standard E03.62.530.N. For more information on this standard please refer to the CNOMO Website www.cnomo.com.

7.4.1 M23 assembly / Installation of PCB

Tool:

VS18/VS26 Philips screwdriver size 1

1. Important: Make sure valves are not already mounted on the valve island, because the Multipole PCB (B) could become damaged during assembly.
2. Insert the Multipole PCB (B) in the left groove of the left end plate and the modular sub-bases. Check to make sure the plug-in connection on the PCB is centred with the orifice to the valve interface.
3. Plug the connector of the M23 E-connector-kit (C) into the connector on the Multipole PCB (B).
4. Ensure connector-kit gasket is fitted on the left end plate.
5. Mount the M23 E-connector-kit (C) with two mounting screws on the left end plate. Tighten the screws with the specified torque. If you are using a power screwdriver consider the maximum speed allowed.

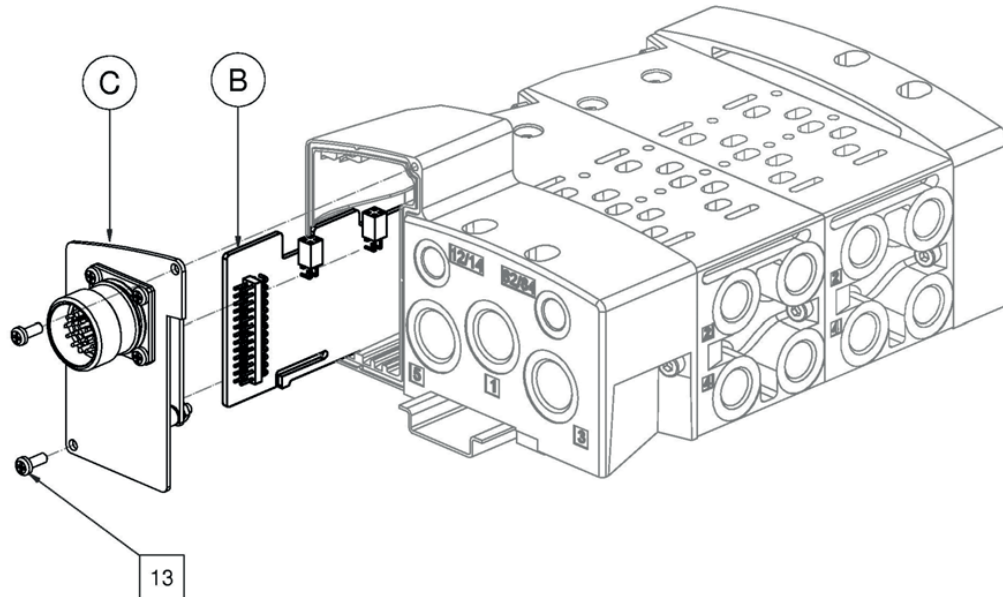

Screw	Type (thread)	Valve size	Tightening torque in Nm	Tightening torque in lbs	Max. screw driver speed in r.p.m.
13	M3x8	VS18/VS26	0.8 – 0.9	7.08 – 7.96	1100

7.4.2 Pin assignment

Pin no.	Wire colour	Socket	Pilot	Station
1	White	Solenoid 8-a	14	8
2	Green/Brown	Solenoid 6-a	14	6
3	Green	Solenoid 4-a	14	4
4	Yellow	Solenoid 2-b	12	2
5	Grey	Solenoid 2-a	14	2
6	Blue (thick)	Common	-	-
7	White/Grey	Solenoid 1-b	12	1
8	Red	Solenoid 3-b	12	3
9	Black	Solenoid 5-b	12	5
10	Violet	Solenoid 7-b	12	7
11	Grey/Pink	Solenoid 7-a	14	7
12	Yellow/Green	Earth	-	-
13	White/Green	Solenoid 6-b	12	6
14	Brown/Green	Solenoid 4-b	12	4
15	White/Yellow	Solenoid 1-a	14	1
16	Yellow/Brown	Solenoid 3-a	14	3
17	Pink	Solenoid 5-a	14	5
18	Red/Blue	Solenoid 8-b	12	8
19	Brown (thick)	NOT USED	-	-

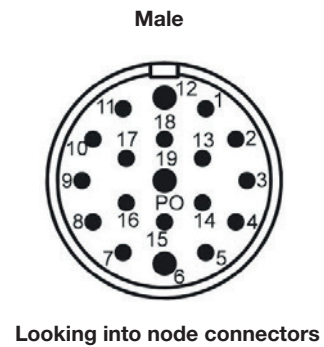

8 FIELDBUS

8.1 GENERAL INFORMATION

VS18/VS26 Fieldbus valve islands range from a minimum of four valve stations to a maximum of 16 valve stations (32 solenoids). The exception to this rule is AS-Interface (see section 8.6). Please refer to section 9 for information on field expansion of the valve island.

VS18/VS26 valve islands are available with below listed Fieldbus protocols. Please refer to the indicated section for detailed information on these protocols.

- Profibus DP Section 8.2
- DeviceNet Section 8.3
- CANopen Section 8.4
- Interbus-S Section 8.5
- AS-Interface Section 8.6

VS18/VS26 Fieldbus valve islands contain electronic devices, which could be damaged through electrostatic discharge. Therefore electrostatic precautions must be taken. Specifically, the person assembling or configuring the valve island must be connected to an earth ground.

The valve island should be mounted on an earthed base to improve the EMC behaviour.

8.1.1 Power supply and pin assignment

VS18/VS26 Fieldbus valve islands are designed to be used with a protective extra low voltage (PELV) power supply (UL Class 2 Supply only) according to IEC 364-4-41. As a result, an earth connection for safety reasons is not required because the supply voltage is restricted to a maximum of 42.2 volts even under fault conditions. However, the earth must be connected. It is not a protective earth, but is required to provide EMC shielding.

The power supply of the Fieldbus valve islands (excluding the version with AS-Interface) are made by an 4-pin M12 connector. Using Profibus DP, a 5-pin 7/8" connector is also available.

M12 4-pin power connector for Fieldbus

Male	Pin no.	Function	Tolerance	Max. current
	1	24 VB logic circuit supply	±25%	300 mA
	2	24 VA valves	±10%	*1)
	3	0 V	–	*2)
	4	Earth	–	–

Note:

Both DeviceNet and CANopen nodes do not use pin 1 of the M12 power connector. This is due to the power for the logic circuit being drawn from the network connection. For details on pin assignment please refer to sections 8.3.1 (DeviceNet) and 8.4.1 (CANopen).

7/8" 5-pin power connector for Profibus DP

Male Communication in	Pin no.	Function	Tolerance	Max. current
	1	–	–	–
	2	0 V	–	*2)
	3	Earth	–	–
	4	24 VA valves	±10%	*1)
	5	24 VB logic circuit supply	±25%	300 mA

*1) $I_{max} = 10mA + n * 60mA$
n = number of energized solenoids

*2) $I_{max} = I_{VA} + I_{VB}$

8.1.2 Max. current load on valve connectors

The digital outputs for activation the pilot valves are optimised for IMI Norgren VS18/VS26 valves. Among compliance of the following data, it is possible to use items from other manufacturers:

- Maximum current: $I_{max} = 85mA$ (if $V_A = 24V DC$)
- Limitation of the inductive interrupting to $U < 40V$
- Pin assignment according to ISO 15407-2
- Output voltage: $U_{output} = U_{supply} - 0.9V$

8.1.3 Fieldbus assembly / Installation of PCBs (excluding AS-Interface)

Tool:

VS18/VS26 Philips screwdriver size 1

1. Important: Make sure valves are not already mounted on the valve island, because the output PCB (C) could become damaged during assembly.
2. Insert first output PCB (C) in the left groove of the left end plate and the modular sub-bases. Check to make sure the plug-in connection on the PCB is centred with the orifice to the valve interface.
3. Insert Fieldbus PCB (B) in the right groove of the left end plate and the modular sub-bases.
4. Plug the lowest connector of the Fieldbus E-connector-kit (A) into the connector on the output PCB (C).
5. Plug the remaining connector(s) of the Fieldbus E-connector-kit (A) into the connector(s) on the Fieldbus PCB (B).
6. Ensure connector-kit gasket is fitted on the left end plate.
7. Mount the Fieldbus E-connector-kit (A) with two mounting screws on the left end plate. Tighten the screws with the specified torque. If you are using a power screwdriver consider the maximum speed allowed.
8. Ensure gasket on the bottom of the LED window (D) is fitted and place the LED window on the left end plate. Turn mounting screws by hand in the existing threads and tighten then by hand.

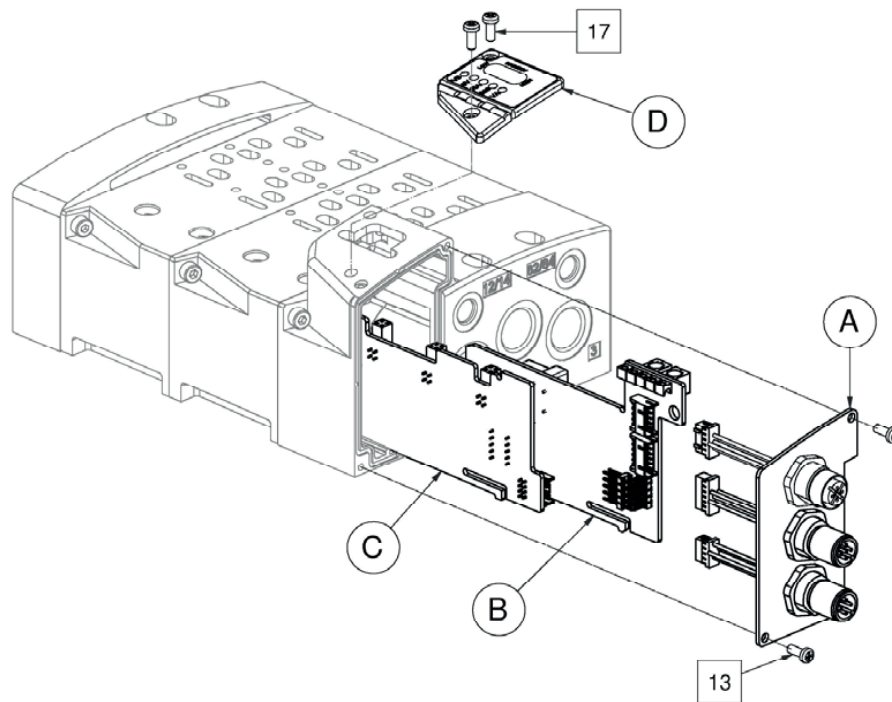

Screw	Type (thread)	Valve size	Tightening torque in Nm	Tightening torque in lbs	Max. screw driver speed in r.p.m.
13	M3 x 8	VS18/VS26	0.8 – 0.9	7.08 – 7.96	1100
17	M3 x 8	VS18/VS26	0.4	3.54	Tighten by hand!

8.1.4 AS-Interface assembly / Installation of PCBs

Tool:

VS18/VS26 Philips screwdriver size 1

1. Important: Make sure valves are not already mounted on the valve island, because the AS-Interface PCB (B) as well as the expansion PCB (C) could become damaged during assembly.
2. Insert the AS-Interface PCB (B) in the middle groove of the left end plate and the modular sub-bases. Consider, that the single station expansion PCB (C), different from the main PCB (B), has to be inserted in the left groove of the left end plate and the modular sub-bases. Check to make sure the plug-in connection on the PCB is centred with the orifice to the valve interface.
3. Plug the lowest connector of the Fieldbus E-connector-kit (A) into the connector on the AS-Interface PCB (B).
4. Plug the other connector of the Fieldbus E-connector-kit (A) into the upper connector on the AS-Interface PCB (B).
5. Ensure connector-kit gasket is fitted on the left end plate.
6. Mount the Fieldbus E-connector-kit (A) with two mounting screws on the left end plate. Tighten the screws then with the specified torque. If you are using a power screwdriver consider the maximum speed allowed.
7. Ensure gasket on the bottom of the LED window (D) is fitted and place the LED window on the left end plate. Turn mounting screws by hand in the existing threads and tighten then by hand.

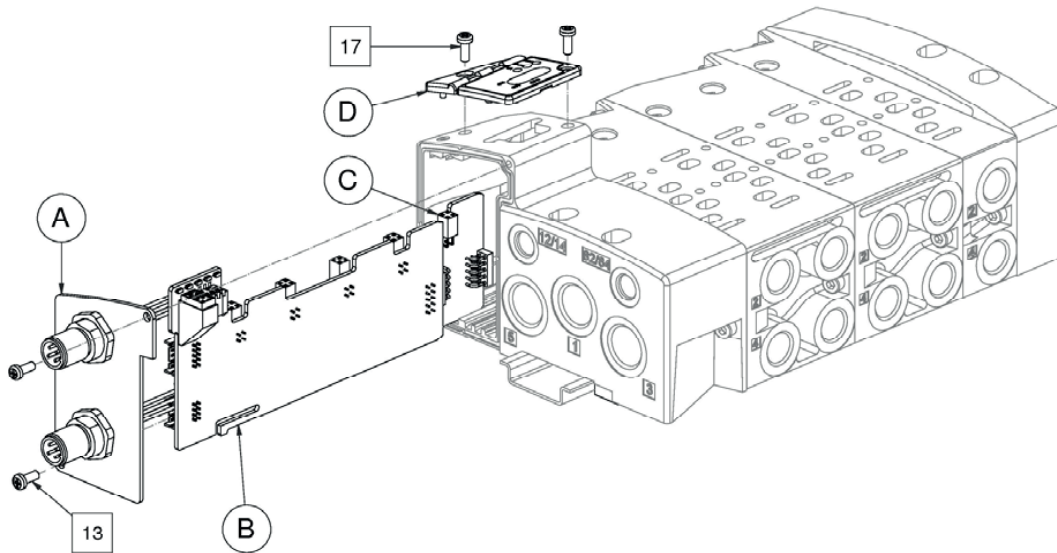

Screw	Type (thread)	Valve size	Tightening torque in Nm	Tightening torque in lbs	Max. screw driver speed in r.p.m.
13	M3 x 8	VS18/VS26	0.8 – 0.9	7.08 – 7.96	1100
17	M3 x 8	VS18/VS26	0.4	3.54	Tighten by hand!

8.2 PROFIBUS DP

IMI Norgren Profibus DP Fieldbus systems conform to DIN 19245 part 3.

Communication system:	2-wire RS485 hardware communication protocol
Baud rate:	9.6 kBit/s to 12 MBit/s. Automatic detection.
Maximum nodes per network:	126
total number of I/O per network:	32256
Bus topology:	Line

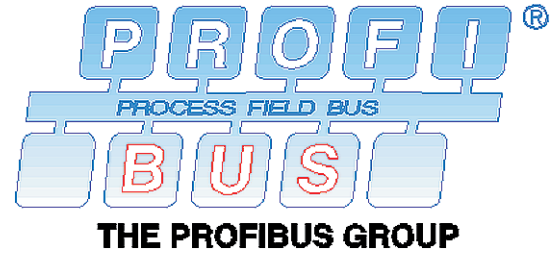

8.2.1 Profibus DP pin assignment

2 x M12 5-pin version (B-coded / IP65)

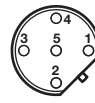
Male Communication in	Female Communication out	Pin no.	Function
		1	5Vl Opto isolated
		2	A-line (green)
		3	OVI Opto isolated
		4	B-line (red)
		5	Shield
		Threaded joint	Shield

1 x D-Sub 9-pin version (IP40)

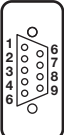
Female Communication in/out	Pin no.	Function
	1	Shield
	2	N/C
	3	A-line (red) Rx/D / Tx/D-P
	4	N/C
	5	DGND (OVI) isolated
	6	VP (5Vl) isolated
	7	N/C
	8	B-line (green) Rx/D / Tx/D-N
	9	N/C

8.2.2 Profibus DP wiring

The bus line is specified in EN 50170 as line type A. It can be used as shown in the following table. The table gives the bus parameters and line lengths of A and B type lines for comparison. However it is recommended that only type A lines should be used, due to their expanded length capabilities.

Line parameter

Parameter	A-line	B-line
Impedance in Ohm	135 to 165	100 to 130
Capacitance per unit length (pF/m)	< 30	< 60
Loop resistance (Ohm/km)	110	-
Core diameter (mm)	0.64	> 0.53
Core cross section (mm ²)	> 0.34	> 0.22

Line lengths

Baud rate (kBit/s)	9.6	19.2	93.75	187.5	500	1'500	12'000
Line A (m)	1'200	1'200	1'200	1'000	400	200	100
Line B (m)	1'200	1'200	1'200	600	200	-	-

Calculating possible line lengths

The maximum admissible distance between two bus stations in each Profibus network can be calculated as follows:

$(NO_REP + 1) * \text{Segment length}$

NO_REP = The maximum number of repeaters connected in series (depends on repeater type).

Example:

The repeater manufacturer's specifications allow nine repeaters to be connected in series. The maximum distance between two bus stations at a data transfer rate of 1'500 kBit/s is then as follows:

$$(9 + 1) * 200 \text{ m} = 2'000 \text{ m}$$

Wiring termination

The active bus termination using a resistor combination avoids signal reflections during data transfer and ensures a defined zero-signal voltage on the data lines when none of the stations on the bus are active. Active termination must be provided at the beginning and end of each RS485 bus segment.

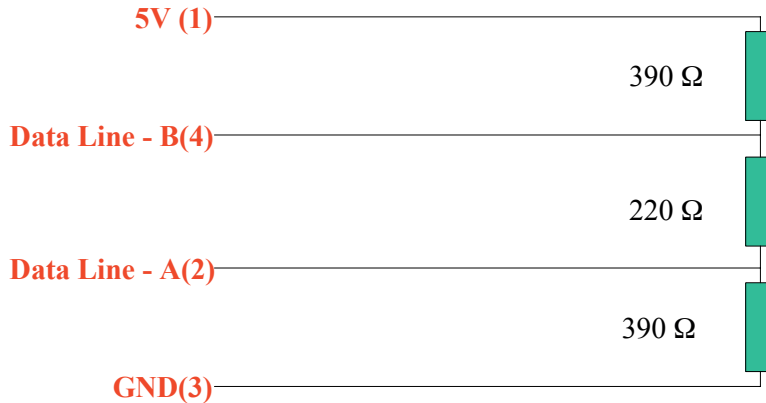

Line termination of wire A in acc. with EN 50 170

If the bus termination is missing, this can cause errors during data transfer. Problems can also arise if too many bus terminators are fitted since each bus terminator also represents an electrical load and reduces the signal levels and thus the signal-to-noise ratio. Too many or missing bus terminators can also cause intermittent data transfer errors, particularly if the bus segment is operated close to the specified limits for maximum numbers of stations, maximum bus segment length and maximum data transfer rate.

The power required by the active bus termination is usually obtained through the bus connector from stations connected to the bus. Alternative measures must be taken if there is no guarantee that the power required by the bus termination is permanently provided while the bus is operating. For example, in a particular installation the station providing the power to the bus termination may need to be repeatedly switched off or removed from the bus for operational reasons. In such cases, the bus termination should use an external power supply or a repeater should be used for bus termination instead.

8.2.3 Profibus DP address and baud rate setting

The VS18/VS26 Profibus DP valve island address can be set within the range 1 to 99 (rotary switch) resp. 125 (software). To set the address, use the selector switches accessible by removing the securing screw and lifting the hinged cover of the address switches. The two rotary switches allow an address range of 1 to 99. The valve island needs a power reset to accept a new address. When position 0 is selected on both switches the address may be set through software via a capable master.

Default address = 125

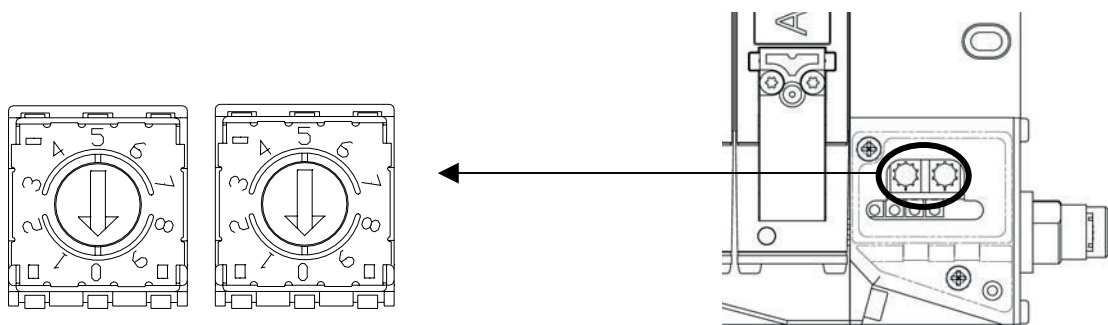

Following are VS18/VS26 Profibus DP baud rates, which are detected automatically

9.60 kBit/s	19.20 kBit/s	45.45 kBit/s	93.75 kBit/s
187.50 kBit/s	500.00 kBit/s	1.50 MBit/s	12.00 MBit/s

8.2.4 Profibus DP output addressing

Valve no.	Data byte_0				Data byte_1				Data byte_2				Data byte_3			
	1	2	3	4	5	6	7	8	9	10	11	12	13	14	15	16
Solenoid 14	0	2	4	6	8	10	12	14	16	18	20	22	24	26	28	30
Solenoid 12	1	3	5	7	9	11	13	15	17	19	21	23	25	27	29	31

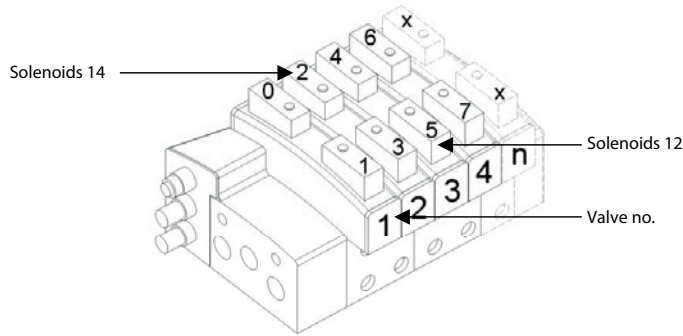

Number of configured output bytes

The number of configured output bytes can be changed if required. The default setting is always on the maximum (4 output bytes). To change the number of outputs you have to remove the Fieldbus PCB and modify the DIP switch as follows:

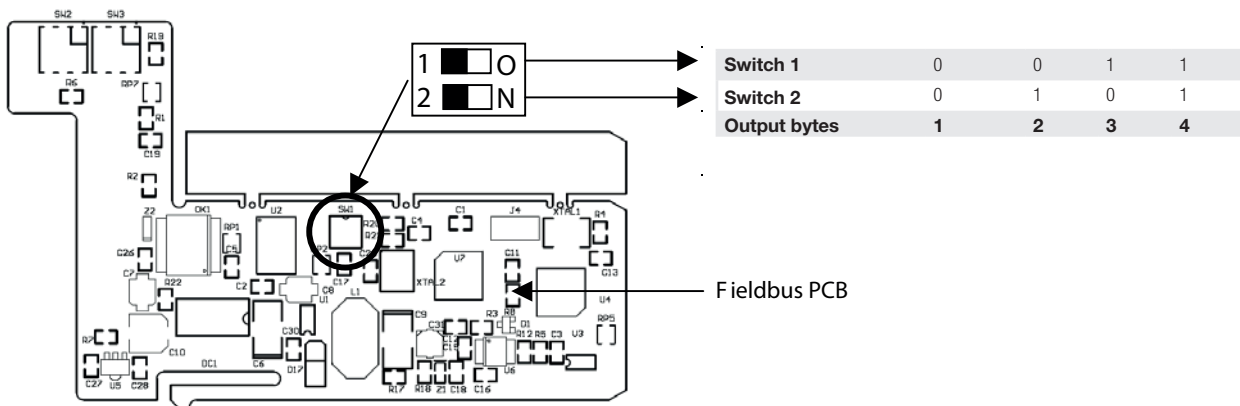

8.2.5 Diagnostics

The VS18/VS26 Profibus DP slave uses diagnostic telegrams as a high-priority response to inform a master of its current state. The first 6 bytes contain the information specified by the standard e.g. status of the state machine, correct/incorrect parameterisation and configuration. Additionally, there is 1 byte of user diagnostics, which is used to show the state of the VA for the valves. By monitoring the first bit of the user diagnostics byte the presence of the valve power can be determined.

8.2.6 Profibus DP LED indicators

VB (green) – This LED will only be energised when 24 volts is applied to the electronics power terminal of the power supply connector.

5V (green) – This LED will only be energised when a 24 volt supply is applied to the electronic supply terminal of the power supply connector, indicating that the logic circuit of the module is powered.

BA (green) – This LED indicates the status of the network traffic, indicating when network packages are received.

VA (green) – This LED will only be energised when 24 volts is applied to the valve power terminal of the power supply connector.

Indicator states during powering up and commissioning

Condition	VB	5V	BA	VA
Power up	on	on	off	on
Changing address during commissioning	on	on	off	on
Device in a stopped state	on	on	off	on
Device in an operation state	on	on	on	on

8.2.7 Profibus DP commissioning

Due to the increasing number of compatible master controllers it would be impractical to create detailed instructions for commissioning the IMI Norgren node on a particular master. All IMI Norgren Profibus products are conformance tested to the latest specification by an independent authorised test site and are fully certified by the Profibus International Group. As a result, the help guide and manual supplied with the users chosen PLC should be used during the commissioning stages of each IMI Norgren node.

8.2.8 GSD file

A GSD file is used to identify a Profibus DP/PA device (master or slave). It contains data making it possible to have manufacturer independent configuration tools. Typical information in a GSD file is vendor information, baud rates supported, timing information, options/features supported and available I/O signals. A GSD file must be available for every DP/PA slave. This is installed into the PLC configuration software loaded into the products catalogue, in the additional field devices section.

8.2.9 Profibus DP valve island expansion

The modular design of the VS18/VS26 valve island allows easy modifications to the number of valves while in the field. The system allows single station expansion for up to 4 valve stations. For more information please refer to section 9.

The VS18/VS26 Profibus DP valve islands may have to be reconfigured after expansion to accept the new number of valves. This is controlled by the DIP switch on the Fieldbus PCB (see section 8.2.4).

8.2.10 More information on Profibus DP

Profibus Group: Profibus DP/FMS Installation Guideline Order Number 2.112

Web sites

www.profibus.com	Profibus Worldwide Organisation
www.profibus.co.uk	Profibus Europe Organisation
www.ad.siemens.de	Siemens Automation and Drives

8.3 DEVICENET

IMI Norgren DeviceNet Fieldbus systems conform to DeviceNet specification volume 1 release 2 and the Pneumatic Valve Device Profile.

DeviceNet™

Communication system: 2-wire CAN hardware communication protocol
 Number of nodes per network: Master + 62 slaves
 Bus topology: Line

8.3.1 DeviceNet pin assignment

M12 5-pin bus connector (A-coded / IP65)

Male communication in	Pin no.	Function	Tolerance	Max. current
	1	Drain	-	-
	2	V+ 24 V *3)	±25%	200mA
	3	V- 0 V *3)	-	-
	4	CAN_H	-	-
	5	CAN_L	-	-

M12 4-pin power connector

Male	Pin no.	Function	Tolerance	Max. current
	1	-	-	-
	2	24 VA valves	±10%	*1)
	3	0 V	-	*2)
	4	Earth	-	-

*1) $I_{max} = 10 \text{ mA} + n \cdot 60 \text{ mA}$

*2) $I_{max} = I_{VA} + I_{VB}$

n = number of energized solenoids

*3) Must be galvanic isolated to 24 VA valves.

8.3.2 DeviceNet wiring

Line parameter

Parameter	Line A (thick cable)	Line B (thin cable)
Impedance in Ohms	120 +/-10%	120 +/-10%
Capacitance per unit length (pF/m)	12	12
Jacket Marking	Vendor name & part number	Vendor name & part number
Core diameter (mm)	#18 Copper 19 Strands	#24 Copper 19 Strands
Outside diameter	0.41 – 0.49 inches	0.24 – 0.28 inches

Line lengths

Baud rate (kBit/s)	Trunk cable length (max.) in m
125	500
250	250
500	100

Wiring termination

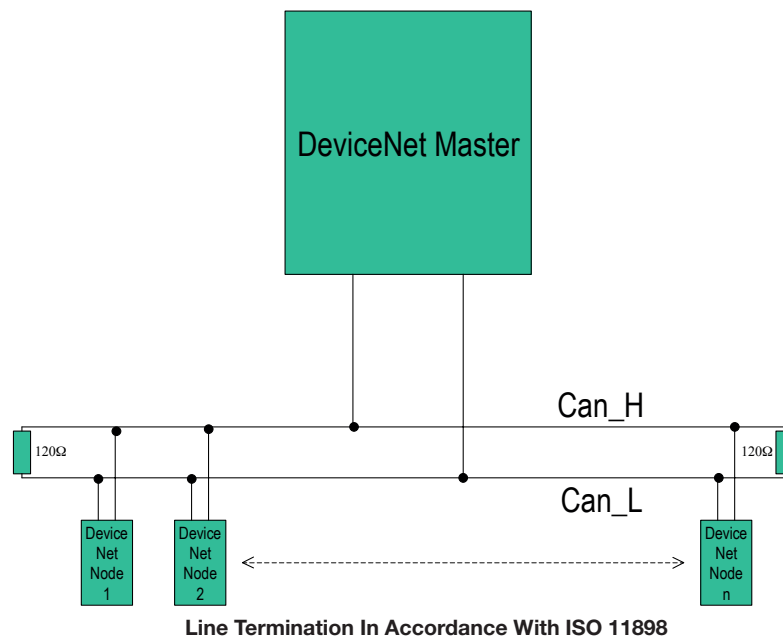

Cable termination is required at both extreme ends of the trunk cable. This can simply be done with a 120Ω resistor between the communication lines or by using purposefully designed terminators that fit into the tee-adapter.

8.3.3 DeviceNet address and baud rate setting

The VS18/VS26 DeviceNet valve island address can be set within the range 0 to 63, set by using the address selector switches accessible by removing the securing screw and lifting the hinged cover of the address switches. The two rotary switches allow an address range of 0 to 63. The valve island needs a power reset to accept a new address. When position 64 is selected the address may be set through software via a capable DeviceNet master. Default address = 63

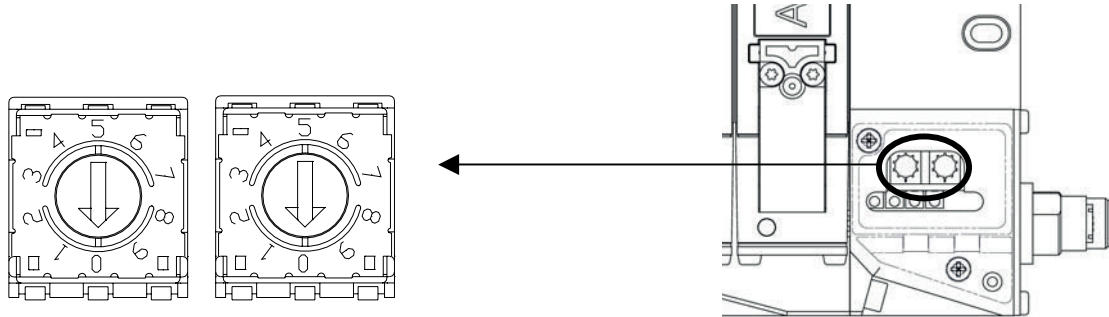

Following are VS18/VS26 DeviceNet baud rates, which are detected automatically:
 125 kBit/s 250 kBit/s 500 kBit/s

8.3.4 DeviceNet output addressing

Valve no. Æ	Data byte_0				Data byte_1				Data byte_2				Data byte_3			
	1	2	3	4	5	6	7	8	9	10	11	12	13	14	15	16
Solenoid 14	0	2	4	6	8	10	12	14	16	18	20	22	24	26	28	30
Solenoid 12	1	3	5	7	9	11	13	15	17	19	21	23	25	27	29	31

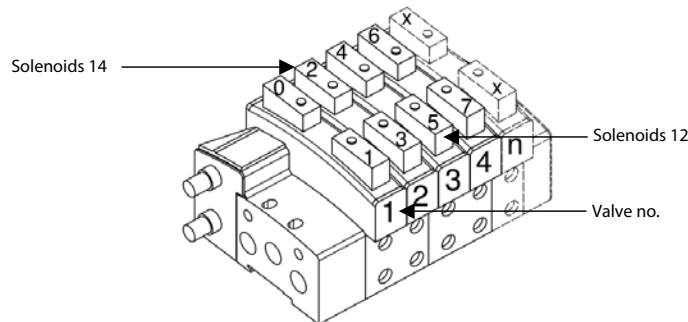

8.3.5 Diagnostics

The VS18/VS26 DeviceNet slave has diagnostic attributes to inform a master of its current state. With these attributes it is possible to monitor the state of the +24V valve power. This can be achieved by using the DeviceNet message: DeviceNet Class Number 3, Instance 1, Attribute Number 0x69, which can be explicitly requested. This message will return 1 byte of data, with value 0x01 indicating that the valve power is present or 0x00 indicating that the valve power is not present.

8.3.6 DeviceNet LED indicators

- VB (green) – This LED will only be energised when 24 volts is applied to the electronics power terminal of the power supply connector.
- 5V (green) – This LED will only be energised when the Network power is connected to the Network connector, indicating that the logic circuit of the module is powered.
- MS (red/green) – This LED indicates the device and whether it is operational or working correctly.
- NS (red/green) – This LED indicates the status of the CAN communication link.
- VA (green) – This LED will only be energised when 24 volts is applied to the valve power terminal of the power supply connector.

Indicator status during powering up and commissioning

Condition	VB	5V	MS	NS	VA
Power up	on	on	single flash	single flash green/red	on
Autom. baud rate detection active	on	on	green	off	on
Changing address during commissioning	on	on	green	green	on
Device in a pre-operation state	on	on	green	flashing green	on
Device in an operation state	on	on	green	green	on
Connection time out	on	on	green	flashing green	on
Failed communication	on	on	green	red	on
Un-recoverable fault	on	on	red	dependant	on

8.3.7 DeviceNet EDS files and commissioning

The electronic data sheet (EDS) library is a collection of EDS files that can be registered with RSNetWorx for Allen Bradley PLC's and Compbus/D configurator for Omron PLC's.

The EDS files, which are provided by IMI Precision Engineering and other manufacturers, contain configuration and identification information for the devices. RSNetWorx for DeviceNet software can access only those devices that have been registered. You must use the EDS Wizard within RS Network for registering EDS files for unknown devices, or if you have updated EDS files to install. To install a new EDS file to your PLC please refer to the PLC manufacturers instruction manual or online help.

Although you receive a large number of electronic data sheet (EDS) files with the configuration software for DeviceNet, there may be a time when you need to acquire other manufactures EDS files from the ODVA www.odva.org (Open DeviceNet Vendor's Association) web site.

DeviceNet node commissioning tool (RS Networx Only)

The DeviceNet node commissioning tool lets you commission, that is, set the node address and the baud rate parameters of, devices that are either connected to a DeviceNet network, or via a point-to-point connection.

Before you can add any node to a live DeviceNet network, it must be commissioned. This means that a node address and a baud rate must be programmed into the device. All IMI Norgren VS18/VS26 nodes are preset with a node address, which is usually set to 63, unless otherwise stated by the user in the valve island configuration. These preset values will need to be changed to meet your application needs. Once a device has been commissioned and attached to a network, you can use the RSNetWorx for DeviceNet node commissioning tool to edit the node address that was set previously. Some devices do not permit software setting of the node address or baud rate. Refer to the device documentation for specific information.

'Tip'

For example, if two of the devices on your network are a photoelectric sensor and a hand controller and you accidentally change the node address of the hand controller to be the same as that of the photoelectric sensor, then the hand controller will no longer have a unique address. This means that it will not be able to communicate on the network. If you cannot access a device because you have used its node address for another device, you will have to remove it from the network, re-commission it and then reinstall it on the network.

8.3.8 DeviceNet valve island expansion

The modular design of the VS18/VS26 valve islands allows easy modifications to the number of valves while in the field. The system allows single station expansion for up to 4 valve stations. For more information please refer to section 9.

8.3.9 More information on DeviceNet

Rockwell Automation:	RS Networx; Getting Results
Allen-Bradley:	DeviceNet Cable System Planning and Installation Manual
Allen-Bradley:	SLC 500/PLC 5 Addressing Reference Manual

Web sites

www.odva.org	Open DeviceNet Vendors Association
www.rockwellautomation.com	Rockwell Automation
www.ab.com	Allen-Bradley

8.4 CANOPEN

IMI Norgren CANopen Fieldbus systems conform to CANopen communication profile CiA DS-301 V4.0.



Communication system: 2-wire CAN hardware communication protocol
Number of nodes per network: Master + 126 slaves
Bus topology: Line

8.4.1 CANopen pin assignment

M12 5-pin bus connector (A-coded / IP65)

Male communication in	Pin no.	Function	Tolerance	Max. current
	1	Drain	-	-
	2	V+ 24 V *3)	±25%	200mA
	3	V- 0 V *3)	-	-
	4	CAN_H	-	-
	5	CAN_L	-	-

*3) Must be galvanic isolated to 24 VA valves.

M12 4-pin power connector

Male	Pin no.	Function	Tolerance	Max. current
	1	-	-	-
	2	24 VA valves	±10%	*1)
	3	0 V	-	*2)
	4	Earth	-	-

*1) $I_{max} = 10 \text{ mA} + n \cdot 60 \text{ mA}$

*2) $I_{max} = I_{VA} + I_{VB}$

n = number of energized solenoids

8.4.2 CANopen wiring

Line parameter

Parameter	Line A (thick cable)	Line B (thin cable)
Impedance in Ohms	120 +/-10%	120 +/-10%
Capacitance per unit length (pF/m)	12	12
Jacket Marking	Vendor name & part number	Vendor name & part number
Core diameter (mm)	#18 Copper 19 Strands	#24 Copper 19 Strands
Outside diameter	0.41 – 0.49 inches	0.24 – 0.28 inches

Line lengths

Baud rate (kBit/s)	Trunk cable length (max.) in m
10	5'000
20	2'500
50	1'000
125	500
250	250
500	100
800	50
1000	25

Line termination

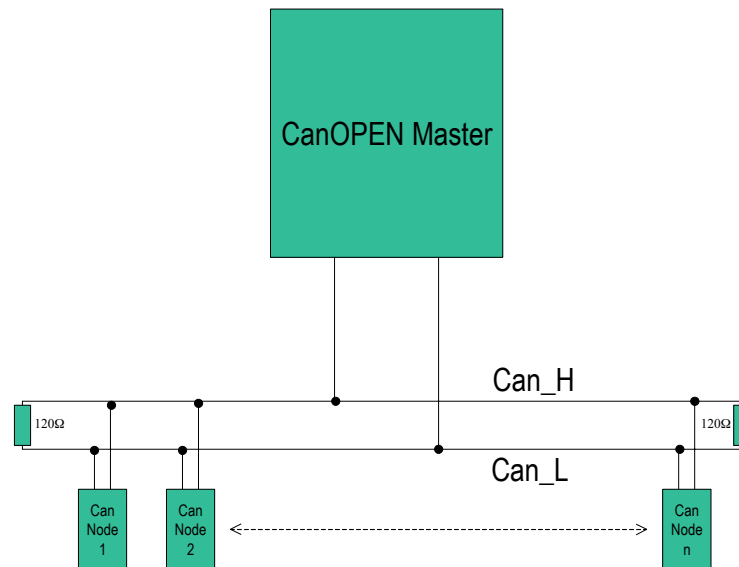

Line Termination In Accordance With ISO 11898

Cable termination is required at both extreme ends of the trunk cable. This can be simply done with a 120Ω resistor between the communication lines or by using purposefully designed terminators that fit into the tee-adapters.

8.4.3 CANopen address and baud rate setting

The VS18/VS26 CANopen valve island address can be set within the range 0 to 99 (rotary switch) resp. 127 (software). To set the address, use the selector switches accessible by removing the securing screw and lifting the hinged cover of the address switches. The two rotary switches allow an address range of 1 to 99. The valve island needs a power reset to accept a new address. When position 0 is selected on both switches the address may be set through software via a capable master.

Default address = 127

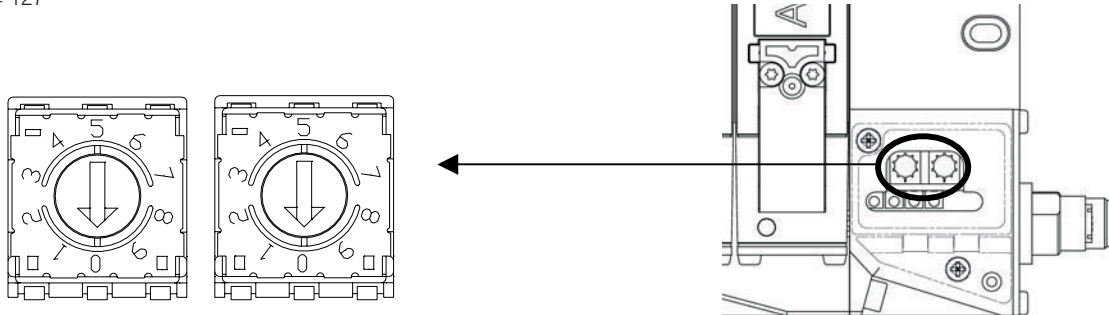

Changing the address of the node via software:

Using a CANopen configuration tool connected to the network, the address of each node may be changed by the following method: Send an SDO Telegram command to the node at SDO index 2100h containing the new node address, valid range 1-127. View example of SDO message below

Description	SDO Index	Sub Index	Value
EEPROM node address	2100h	0	1 - 127

The IMI Norgren CANopen node also supports the layer setting service (LSS). The following configuration services are available

Service	COB-ID	Byte 0	Byte 1	Byte 2	Byte 3	Byte 4	Byte 5	Byte 6	Byte 7
Switch Mode Global	2021h	CS=04	Mode	Reserved					
Configure Node ID	2021h	CS=17	Address	Reserved					
Configure Bit Timing	2021h	CS=19	Table Selector	Table Index	Reserved				
Activate Bit Timing	2021h	CS=21	Switch Delay		Reserved				
Store Configuration	2021h	CS=23	Reserved						

Following are VS18/VS26 CANopen baud rates, which are detected automatically

10 kBit/s	20 kBit/s	50 kBit/s	125 kBit/s
250 kBit/s	500 kBit/s	800 kBit/s	1000 kBit/s

8.4.4 CANopen output addressing

Valve no.	Data byte_0				Data byte_1				Data byte_2				Data byte_3			
	1	2	3	4	5	6	7	8	9	10	11	12	13	14	15	16
Solenoid 14	0	2	4	6	8	10	12	14	16	18	20	22	24	26	28	30
Solenoid 12	1	3	5	7	9	11	13	15	17	19	21	23	25	27	29	31

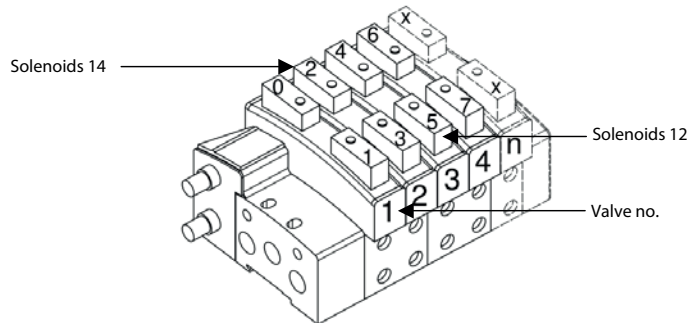

8.4.5 Diagnostics

The VS18/VS26 CANopen slave has a diagnostic attribute to inform a master of its current state. With this attribute it is possible to monitor the state of the +24V valve power. This can be achieved by using the CANopen SDO Object Dictionary: Index 0x2102, Sub_Index0. This message will return 1 byte of read only data, with value 0x01 indicating that the valve power is present or 0x00 indicating that the valve power is not present.

8.4.6 CANopen LED indicators

- VB (green) This LED will only be energised when 24 volts is applied to the electronics power terminal of the power supply connector.
- 5V (green) This LED will only be energised when the Network power is connected to the Network connector, indicating that the logic circuit of the module is powered.
- ER (red) This LED indicates the status of the CAN physical and indicates errors due to missing CAN messages (SYNC, GUARD or HEARTBEAT).
- RN (red/green) This LED indicates the status of the CANopen network state machine.
- VA (green) This LED will only be energised when 24 volts is applied to the valve power terminal of the power supply connector.

Indicator status during powering up and commissioning

Condition	VB	5V	ER	RN	VA
Power up	on	on	single flash	single flash green/red	on
Autom. baud rate detection active	on	on	flickering	flickering green	on
Changing of address during commissioning	on	on	flickering	flickering green	on
Device in a pre-operation state	on	on	off	blinking green	on
Device in a stopped state	on	on	off	single flash green	on
Device in an operation state	on	on	off	on green	on

Indicator status during CAN message Errors

Condition	VB	5V	ER	RN	VA
Too many error frames received	on	on	single flash	dependent on device state	on
Heartbeat event has occurred	on	on	double flash	dependent on device state	on
A sync message has not been received	on	on	triple flash	dependent on device state	on
Bus off	on	on	on	dependent on device state	on

8.4.7 CANopen commissioning

Due to the increasing number of compatible CANopen master controllers it would be impractical to create detailed instructions for commissioning the IMI Norgren node on a particular master. All IMI Norgren CANopen products are conformance tested to the latest specification by an independent authorised test site and are fully certified by the CIA (CAN in Automation). Because of this, the help guide and manual supplied with the users chosen PLC should be used during the commissioning stages of each IMI Norgren node.

8.4.8 CANopen valve island expansion

The modular design of the VS18/VS26 valve islands allows easy modifications to the number of valves while in the field. The system allows single station expansion for up to 4 valve stations. For more information please refer to section 9.

8.4.9 More information on CANopen

- CiA: CiA DS 301-V4.01 CANopen Application Layer and Communication Layer
- CiA: CiA DR 303-V1.1 CANopen Cabling and Connector Pin Assignment
- CiA: CiA DR 305-V1.0 CANopen Layer Setting Services and Predocol (LSS)

Web sites www.can-cia.org/canopen CAN in Automation

8.5 INTERBUS-S

IMI Norgren Interbus-S Fieldbus systems conform to DIN19258.

Communication system:	4-wire RS422 hardware communication protocol
Number of nodes per network:	Master + 512 nodes including remote slaves
Total number of I/O per network:	4096
Bus topology:	Ring

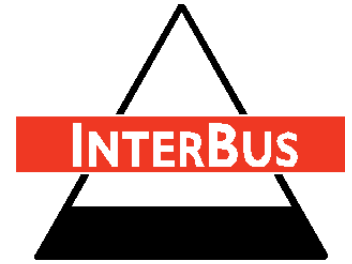

Note:

- VS18/VS26 Interbus-S valve islands are intended for connection to the Interbus-S remote bus system only.
- The valve island must be mounted on an earthed base to meet the EMC directives.

8.5.1 Interbus-S pin assignment

Bus connector: D-Sub; 9-pin (IP65)

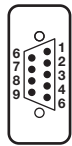
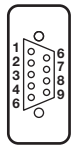
Male Communication in	Female Communication out	Pin no.	Function male	Function female
		1	DO	DO
		2	DI	DI
		3	OVI	OVI
		4	-	-
		5	-	-
		6	/DO	/DO
		7	/DI	/DI
		8	-	-
		9	-	-

The VS18/VS26 Interbus-S valve islands do not automatically recognize whether an additional device is connected on the outgoing connector or not. It is not necessary to add a bridge between pin 5 and pin 9.

8.5.2 Interbus-S wiring

Line parameter

Parameter	Lütze (manufacturer)
Impedance in Ohms	158
Outer jacket	PVC
Core diameter (mm)	3*2*0.25
Outside diameter (mm)	8.6

Line lengths

Transmission rate in kBit/s	500
Main line between nodes	400m
Maximum length	13km

8.5.3 Interbus-S address and baud rate setting

The address of the valve island outputs are determined by the physical position in the Interbus Network.

The baud rate is fixed at 500 kBit/s.

8.5.4 Interbus-S output addressing

Output addressing of the VS18/VS26 Interbus-S valve island varies with different PLC manufacturers and due to the increasing number of compatible Interbus-S master controllers, it would be impractical to create detailed instructions for the IMI Norgren node's output addressing on a particular master.

8.5.5 Diagnostics

The VS18/VS26 Interbus-S slave can determine the state of the +24V for the valves and report any errors to the Interbus-S master. If the valve power is not present the master will show at the time of configuration that a peripheral fault has occurred.

8.5.6 Interbus-S LED indicators

- VB (green) – This LED will only be energised when 24 volts is applied to the electronics power terminal of the power supply connector.
- UL (green) – This LED will only be energised when the Network power is connected to the Network connector, indicating that the logic circuit of the module is powered.
- RC (green) – This LED will only be energised when a cable connection is made to the incoming connector of the device.
- BA (green) – This LED will only be energised when communication is established on the network from the master.
- RD (yellow) – This LED will only be energised when no connection is made to the device, or the master is in an offline state.
- VA (green) – This LED will only be energised when 24 volts is applied to the valve power terminal of the power supply connector.

Indicator status during powering up and commissioning

Condition	VB	UL	RC	BA	RD	VA
Power up	on	on	off	off	on	on
No operation state (master offline)	on	on	on	off	on	on
Establishing communication with master	on	on	flickering	on	off	on
Device in an operation state	on	on	on	on	off	on

8.5.7 Interbus-S ID and length codes

VS18/VS26 Interbus-S valve islands only offer output connections and each size of Interbus node is configured to the maximum possible appropriate number of outputs and stores the corresponding ID code.

Possible VS18/VS26 Interbus-S ID codes:

Number of stations	Number of solenoids	ID code	Length code	DIP switch 1	DIP switch 2
4	8	05h	09h	off	off
8	16	05h	01h	on	off
12	24	05h	0Bh	off	on
16	32	05h	02h	on	on

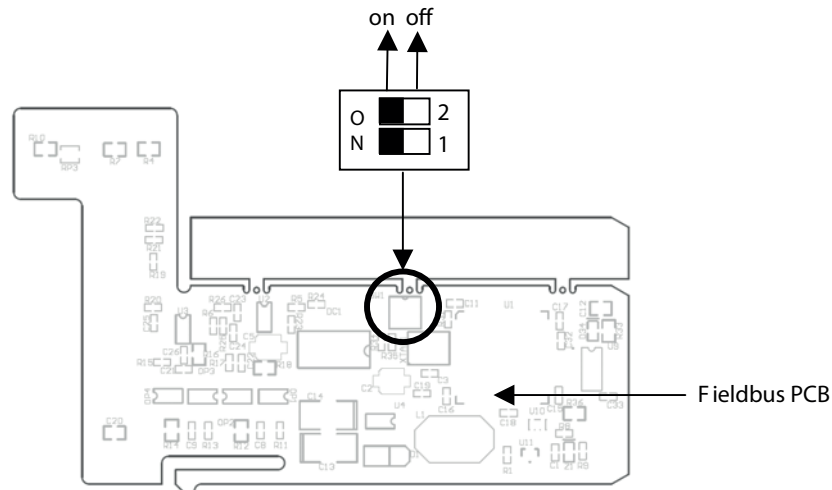

8.5.8 Interbus-S commissioning

Due to the increasing number of compatible Interbus-S master controllers it would be impossible to create detailed instructions for commissioning the IMI Norgren node on a particular master. All IMI Norgren Interbus products are conformance tested to the latest specification by an independent authorised test site and are fully certified by the Interbus Club. Because of this, the help guide and manual supplied with the users chosen PLC should be used during the commissioning stages of each IMI Norgren node.

8.5.9 Interbus-S valve island expansion

The modular design of the VS18/VS26 valve island allows easy modifications to the number of valves while in the field. The system allows single station expansion for up to 4 valve stations. For more information please refer to section 9.

The VS18/VS26 Interbus-S valve islands may have to be reconfigured after expansion to accept the new number of valves. This is controlled by the DIP switch on the Fieldbus PCB (see section 8.5.7).

8.5.10 More information on Interbus-S

Interbus Club: Interbus Basics

Web sites

www.interbusclub.com Interbus Club Organisation

8.6 AS-INTERFACE

IMI Norgren AS-Interface Fieldbus systems conform to AS-I V2.11 specification.

Communication system:	2-wire ASi bus communication, electronic and input power
Number of nodes per network:	Master + 31 slaves (62 slaves for V2.1-slaves which do not use four outputs). The VS18/VS26 ASi valve islands always has four outputs.
Total number of I/O per network:	248
Bus topology:	Tree



Note:

The valve island must be mounted on an earthed base to meet the EMC directives.

8.6.1 AS-Interface pin assignment

Bus connector: M12; 4-pin

Male Communication in/out	Pin no.	Function	Max. current
	1	AS-I	*3)
	2	–	–
	3	AS-I	–
	4	–	–

Power connector: M12; 4-pin

Male	Pin no.	Function	Tolerance	Max. current
	1	24 V d.c.	±10%	*4)
	2	–	–	–
	3	0 V	–	–
	4	–	–	–

*3) Single slave: 40 mA; Double slave: 75 mA

*4) Single slave: $I_{max} = 20 \text{ mA} + n \cdot 60 \text{ mA}$; Double slave: $I_{max} = 35 \text{ mA} + n \cdot 60 \text{ mA}$
 n = number of energized solenoids

8.6.2 AS-Interface wiring

2-wire unshielded cable (ASi bus specific IDC type) or other 2-wire cable with sufficient current capacity. Similar cable can be used for external power cables.

Line length

Line lengths are up to 100m, including all branches, however longer line lengths are possible with repeaters.

8.6.3 AS-Interface address and baud rate setting

The addresses of the two AS-Interface nodes built into a VS18/VS26 valve island are set by using a master controller or hand-held addressing device. The baud rate is fixed 125Kb.

Default address single slave = 0

Default address double slave: Slave1 = 1

Slave2 = 2

8.6.4 AS-Interface single slave valve island configurations and settings

The VS18/VS26 AS-Interface single slave valve island can have two to four valve stations with a maximum of four outputs. To change the configuration, operate the DIP switches accessible by removing the securing screw and lifting the hinged cover.

Single slave Mode	DIP switch	
	1	2
2 valves 2 x sol/sol	1	1
3 valves 1 x sol/sol 2 x sol/spring	1	0
4 valves 4 x sol/spring	0	0

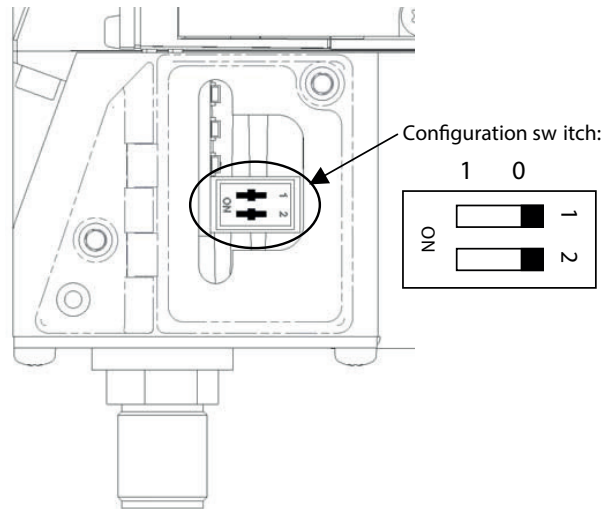

8.6.5 AS-Interface single slave output addressing

Allocation of data bytes and data bits to solenoids

No. of valves	Valve no.	Data byte.Data bit (eg. byte 0/bit 3 → 0.3)			
		1	2	3	4
2 valves	Solenoid 14	0.0	0.1		
	Solenoid 12	0.3	0.2		
3 valves	Solenoid 14	0.0	0.1	0.2	
	Solenoid 12	0.3			
4 valves	Solenoid 14	0.0	0.1	0.2	0.3
	Solenoid 12				

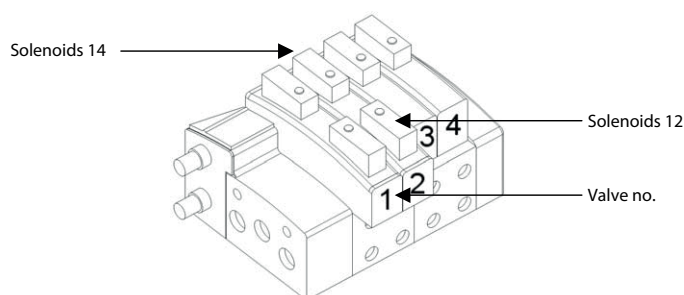

8.6.6 AS-Interface double slave valve island configurations and settings

The VS18/VS26 AS-Interface double slave can have four to eight valve stations with a maximum of eight outputs. To change the configuration, operate the DIP switches accessible by removing the securing screw and lifting the hinged cover. During setting the slaves addresses of the double slave, only one ASi slave should be connected to the bus. To do this use switch settings form diagram below:

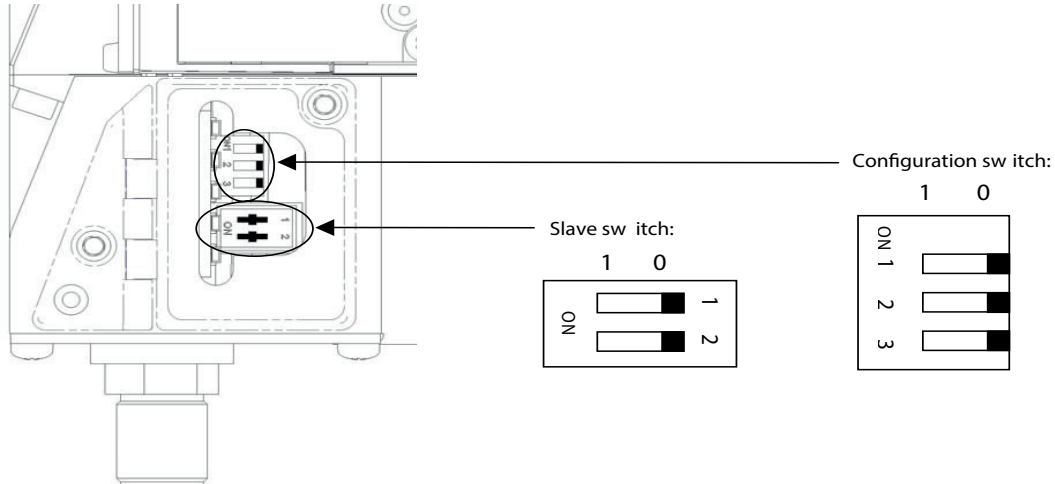

Slave switch

DIP switch	2	1
ASi_1	0	1
ASi_2	1	0

Configuration switch

Double slave Mode	DIP switch		
	1	2	3
4 valves			
4 x sol/sol	1	1	1
5 valves			
3 x sol/sol & 2 x sol/spring	1	0	0
6 valves			
2 x sol/sol & 4 x sol/spring	1	1	0
7 valves			
1 x sol/sol & 6 x sol/spring	0	1	1
8 valves			
8 x sol/spring	1	0	1

8.6.7 AS-Interface double slave output addressing

Allocation of data bytes and data bits to solenoids

No. of valves	Valve no.	Data byte.Data bit (eg. byte 0/bit 3 → 0.3)							
		1	2	3	4	5	6	7	8
4 valves	Solenoid 14	0.0	0.2	1.0	1.2				
	Solenoid 12	0.1	0.3	1.1	1.3				
5 valves	Solenoid 14	0.0	0.2	1.0	1.2	1.3			
	Solenoid 12	0.1	0.3	1.1					
6 valves	Solenoid 14	0.0	0.2	1.0	1.1	1.2	1.3		
	Solenoid 12	0.1	0.3						
7 valves	Solenoid 14	0.0	0.2	0.3	1.0	1.1	1.2	1.3	
	Solenoid 12	0.1							
8 valves	Solenoid 14	0.0	0.1	0.2	0.3	1.0	1.1	1.2	1.3
	Solenoid 12								

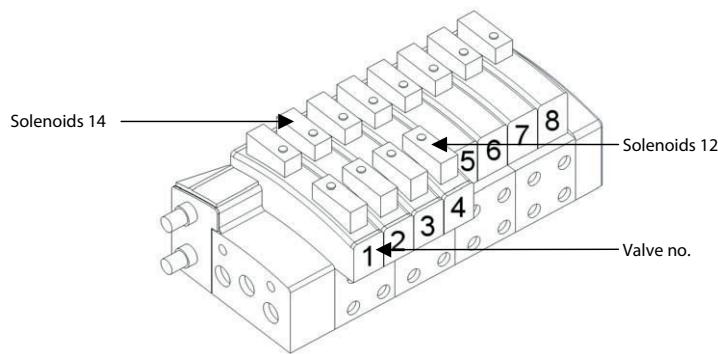

8.6.8 Diagnostics

The VS18/VS26 AS-Interface slaves report missing +24V for the valves to the ASi master as a peripheral fault. If the valve power is not present the red LED is blinking too.

8.6.9 AS-Interface LED indicators

- ASI 1 (green) – This LED will only be energised when the Network power is connected to the Network connector, indicating that the ASi 1 logic circuit of the module is powered.
- DG 1 (red) – This LED indicates the status of the 1st ASi IC.
- ASI 2 (green) – This LED will only be energised when the Network power is connected to the Network connector, indicating that the ASi 2 logic circuit of the module is powered.
- DG 2 (red) – This LED indicates the status of the 2nd ASi IC.
- VA (green) – This LED will only be energised when 24 volts is applied to the valve power terminal of the power supply connector.

Indicator status during powering up and commissioning

Condition	ASI 1	DG 1	ASI 2	DG 2	VA
Power up	on	on	on	on	on
Device in a pre-operation state	on	on	on	on	on
Device in an operation state	on	off	on	off	on
Valve power is missing	on	blinking	on	blinking	off

8.6.10 AS-Interface ID and I/O configuration codes

AS-Interface profile: S-8.F.E
 I/O configuration [hex]: 8
 ID-Code [hex]: F.E

8.6.11 AS-Interface commissioning

Due to the increasing number of compatible ASi 2.11 master controllers it would be impractical to create detailed instructions for commissioning the IMI Norgren node on a particular master. All IMI Norgren AS-Interface products are conformance tested to the latest specification by an independent authorised test site and are fully certified by the AS-Interface international group. Because of this, the help guide and manual supplied with the users chosen PLC should be used during the commissioning stages of each IMI Norgren node.

8.6.12 AS-Interface valve island expansion

The modular design of the VS18/VS26 valve islands allows easy modifications to the number of valves while in the field. The AS-Interface system allows a single station expansion according to the indicated configurations (see section 8.6.5 and 8.6.7). For more information please refer to section 9.

The VS18/VS26 AS-Interface valve islands may have to be reconfigured after expansion to accept the new number of valves and correct allocation of the output bits. This is controlled by the DIP switch on the Fieldbus PCB (see section 8.6.4 and 8.6.6).

8.6.13 More information on AS-Interface

Web sites: www.as-interface.net : AS-Interface International Organisation

9 VALVE ISLAND EXPANSION

9.1 GENERAL INFORMATION

A configured Multipole or Fieldbus valve island is single step expandable up to a maximum of 4 additional valve stations. Confirm your valve island has not used any additional stations before proceeding.

- In case of even number of stations, the valve island is expandable up to 4 additional valve stations.
- In case of odd number of stations, the valve island is expandable up to 3 additional valve stations because the last sub-base is a single additional station.
- The maximum number of valve stations is 16 (32 solenoids).

Note:

- When changing number of valve stations of a valve island, the part number on the label will no longer correspond to the configuration. If you order the valve island based on the IMI Norgren part number, the original configuration will be delivered.
- If more than 4 additional valve stations are required to be added to the main PCB, the main PCB must be changed.
- Fieldbus valve islands may have to be reconfigured after expansion. Please refer to the specific information for each Fieldbus protocol in section 8.
- For expansion of an AS-Interface valve island, please refer to section 8.6.5 and 8.6.7.
- Please notice the position of blanking discs (multi pressure) before you expand a valve island (see section 5.1.7).
- Fieldbus valve islands contain electronic devices, which could be damaged through electrostatic discharge. Therefore electrostatic precautions must be taken. Specifically, the person assembling or configuring the valve island must be connected to an earth ground.

To expand the VS18/VS26 valve island, expansion sets (A) are available. The set includes:

- 1 single station modular sub-base (C)
- 1 gasket (D)
- 2 socket screws
- 1 single station expansion PCB (E)
(Valves and accessories to be ordered separately.)

9.2 ASSEMBLY OF SINGLE ADD-ON STATIONS FOR MULTIPOLE AND FIELDBUS VALVE ISLANDS

Tools:

- VS18: Hexagon wrench key 2.5mm
VS26: Hexagon wrench key 3mm

1. To expand the valve island, disassemble the right end plate (B) by loosening the mounting screws.

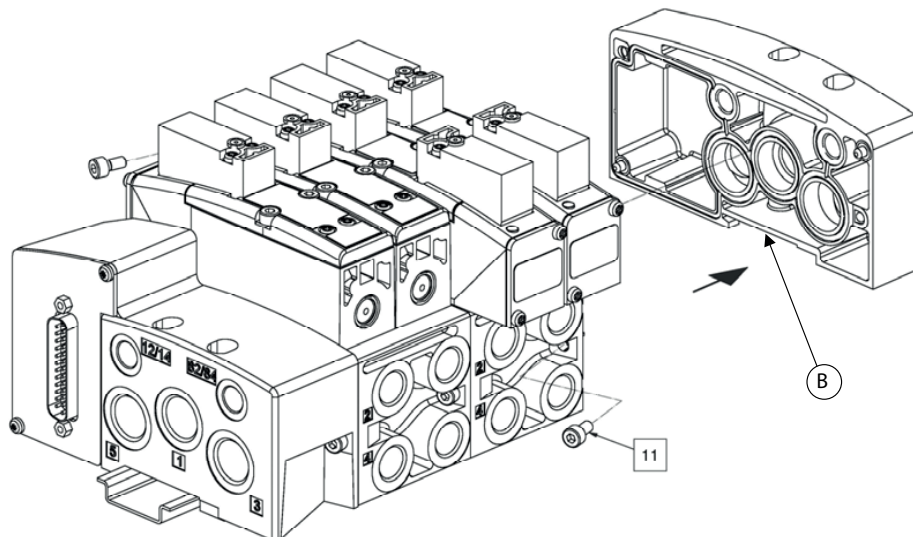

2. Ensure gasket (D) is fitted before you mount the additional single station modular sub-base (C). Then bolt the single station modular sub-base (C) together with the existing modular sub-base. Tighten mounting screws (two per modular sub-base) with the specified torque. If you are using a power screwdriver consider the maximum speed allowed.
3. Insert carefully the expansion PCB (E) in the same groove of the modular sub-base as the main PCB. (The exception to this rule is AS-Interface. Please refer to section 8.1.4.) Check to make sure the plug-in connection on the PCB is centred with the orifice for the valve interface.
4. Repeat steps 2 and 3 if you expand the valve island with more than one station.
5. Ensure end plate gasket is fitted before you remount the right end plate (B) to the modular sub-base. Tighten mounting screws (two per end plate) with the specified torque. If you are using a power screwdriver consider the maximum speed allowed.
6. Ensure valve body gasket is fitted on the bottom of the additional valve (F). Place additional valve (F) onto the modular sub-base (C) aligned to the interface. Use plug-in connection as positioning point.
7. VS26 only: Orientate straight flange of the U-washers towards the outer edge of the valve.
8. Tighten valve mounting screws (two per valve) with the specified torque. If you are using a power screwdriver consider the maximum speed allowed.
9. Repeat steps 6 and 8 if you expand the valve island with more than one station.

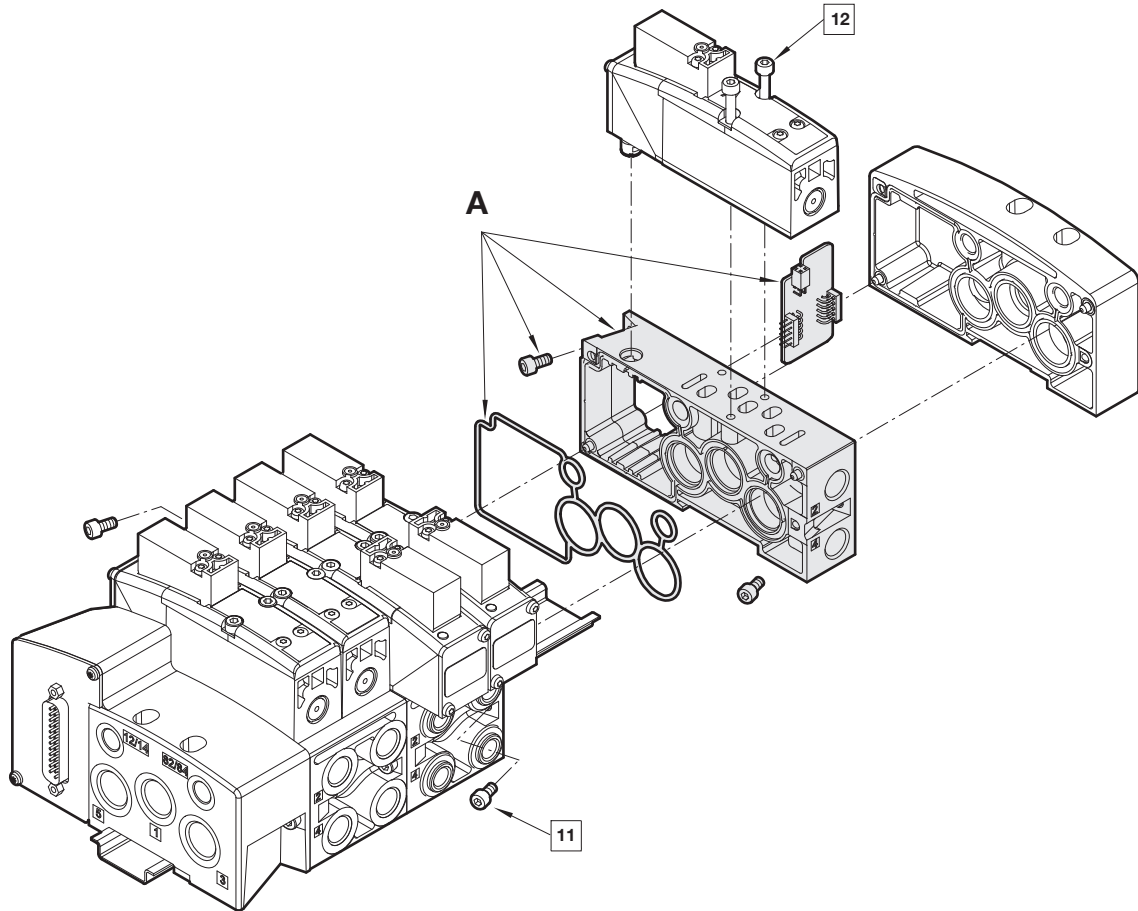

Screw	Type (thread)	Valve size	Tightening torque in Nm	Tightening torque in lbs	Max. screw driver speed in r.p.m.
11	M3 x 10	VS18	0.8 – 0.9	7.08 – 7.96	1100
11	M4 x 12	VS26	1.0 – 1.1	8.85 – 9.73	1100
12	M3 x 40	VS18	0.8 – 0.9	9.73 – 13.27	1100
12	M4 x 43	VS26	1.2 – 1.6	10.62 – 14.16	1100

10 USE IN AREAS WITH POTENTIALLY EXPLOSIVE ATMOSPHERE (2014/34/EU „ATEX“) – OPERATING MANUAL AND DECLARATION OF CONFORMITY

The information in this section is valid for all ATEX valve islands and overrides any conflicting information in other sections.

10.1 INTENDED USAGE

Please review all ATEX data and notes in this maintenance and instruction booklet to eliminate any risks which would jeopardize the safe function of the valve island. Any use beyond the permissible limits, or the failure to comply with the instructions of this booklet, will cause the user to be liable for damages. In case of non-permissible intrusions or modifications of the valve island, as well as failing to comply with the instructions of this booklet, the claim for guarantee expires and our liability is excluded. The valve island must be used only with non-combustible mediums which do not corrode, chemically or mechanically, the materials used. Use only mediums approved by IMI Precision Engineering.

10.2 OPERATING MANUAL ATEX

10.2.1 General conditions

- VS18/VS26 valve islands mentioned in this manual must be used with permissible valves, plates and accessories from IMI Precision Engineering. In case of use with products of other manufacturers, IMI Precision Engineering assumes no liability. Moreover the EX approval as well as the claim of guarantee expires for items of equipment and accessories.
- The ATEX approval applies exclusive to the valve island with the original configuration shipped by IMI Precision Engineering.
- The valve island must be used with the original configuration only. If a modification of the configuration is needed, it must be taken by IMI Precision Engineering or by a body notified by IMI Precision Engineering only whereas the part number of the valve island will change.
- To achieve ATEX conformity, ATEX approved plugs and cables must be used. Please refer to section 10.3.3 for requirements.
- Please consider the information of this operating manual as well as the use conditions and permissible data, which are on the product labels.
- Before installation, the specifications of the device identification are to be compared with the intended operating conditions to ensure proper usage.
- Take measures to avoid unintentional or improper activation.
- Prior to the first electrical operation, ensure no danger would result from the medium exhausting from any open ports.
- Consider in case of pressurised systems that lines, valves and other components should not be removed.
- ATTENTION: There is some risk of injury! The surface of pilot valves could become very warm in continuous operation.
- Leak and strength tests on open and closed valves are admissible until max. 1.5 times the max. operating pressure. It is not allowed to operate the valve during these tests.
- Do not use inlet air of an area with potentially explosive atmosphere.
- Never use the valve island as lever arm or a step for climbing.

10.2.2 Installation

Please consider following points before assembling and installing the valve island:

- Check if classification of the valve island, the permissible application area and marking on the item of equipment are suitable for the application.
- Check technical data, such as operating pressure, voltage level, current type and temperature, on the product label or in the data sheets for compliance with the existing operating conditions.
- After removing the packaging, make sure that no contamination enter into the system.
- Check before the installation of the system that no contamination exists in the piping and valve island.
- Check during installation of the system that gaskets will not become damaged.

Please consider following points during the installation of the valve island:

- The installation must be taken by qualified personnel with consideration of relevant regulations.
- Any fitting position of the valve island is permissible but valves with indicating lights up is preferred.
- To avoid damaging the product, please make sure that the maximum torque values are not exceeded (see section 5.1.2).
- Prevent connector cables and cords from sharp bends in order to avoid short circuits and interruptions.
- Damaged parts must be replaced with original spare parts from IMI Norgren.
- Order spare parts with the part number indicated on the product labels. (See section 5.2.2 and/or data sheets 5.1.250 (VS18) resp. 5.1.350 (VS26)).
- For equal potential bonding link all electro-conductive parts including accessories together.
- Ground the complete system.
- **Important:** Power must be removed from the system while assembling and disassembling electrical connectors, plugs and cables, valves, sandwich plates and blanking plates.
- **Important:** Power must be removed from the system while opening or disassembling the valve island. The same applies for the hinged cover of the address switches of certain Fieldbus variants. Power must be removed when operating the address switches.

10.2.3 Operating

- Ensure before commissioning of the valve island, that the whole equipment/machine conform to the provisions of the machine, ATEX and EMC directives as well as other applicable standards and directives.
- The valve island must be used only with air, which does not corrode the system and the contained sealing materials (see also section 4).
- Avoid contact with liquid and corrosive mediums.
- Please refer to section 10.3.1 for maximum permissible operating conditions for valve islands in an ATEX zone.
- Do not load the system by bending or torsion.

10.2.4 Failures

- In case of failure check the connection of pipes, the operating voltage as well as the operating pressure.
- With Fieldbus valve islands, check the LED indicators and the PLC for error messages. Please refer to section 8 for the definition of LED indicators.
- Any service or repair work as well as replacement of components must be taken in unpressurized condition. Also, power must be removed from the system.
- **Important:** It is not allowed to detach a plug or to open a body in a zone with potentially explosive atmosphere when power is not removed.

10.2.5 Maintenance and repair

Maintenance, inspection and assembly work must be taken by authorised and qualified personnel. Work on pilot valves in general must be taken in unpressurized and cooled off condition. Also, power must be removed from the system. It is recommended to make precautionary maintenance depending on the operating conditions and in case of significant changes in response times. The user is liable for adequate test and maintenance spacing dependent on the operating conditions of the valves. Precipitation, contamination, and aged or worn gaskets can cause failures. Gaskets must be included to ensure the protection class. Damaged parts must be replaced with original spare parts from IMI Norgren. If connectors are removed, be aware of dust contamination in the connectors.

10.3 ATEX CONFORMITY

10.3.1 Operating conditions

ATTENTION: Certain permissible operating conditions for ATEX applications can vary from normal applications.

Pilot pressure:	max. 10 bar	
Operating pressure:	max. 16 bar	(if permissible for valve type)
Ambient temperature:	-15°C to 50°C	
Medium temperature:	max. 50°C	
Medium:	compressed air, filtered, lubricated	(see section 4.1.4 for air quality)
Temperature class:	T4	(see declaration of conformity 10.3.4)
ATEX category:	II3GD	(see declaration of conformity 10.3.4)
Voltage:	24V DC	(+/-10%)
Wattage of pilot valves:	1,2W	(per pilot valve)
Maximal Power consumption allowed:	20W	(only 16 pilot valves energized permanently)
Use conditions:	100% ED	

Note:

1. The valve islands VS18 and VS26 conform to the Directive 2014/34/EU „equipment of the equipment group II category 3G“, which are potentially explosive through inflammable material in range of temperature class T1 to T4 in zone 2 as well as in the explosions groups IIA, IIB and IIC according to Directive 99/92/EC (ATEX 137) and can be used correspondingly. Follow the requirements in EN 60079-15 using/installing the valve islands.

2. The valve islands VS18 and VS26 conform to the Directive 2014/34/EU „equipment of the equipment group II category 3D“, which can be used in zone 22 of inflammable dusts according to Directive 99/92/EC (ATEX 137). Follow the requirements in EN 60079-31 using/installing the valve islands.

10.3.2 Labels

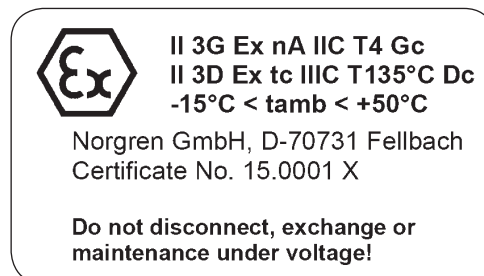
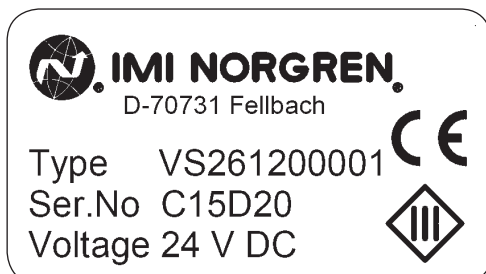

Multipole

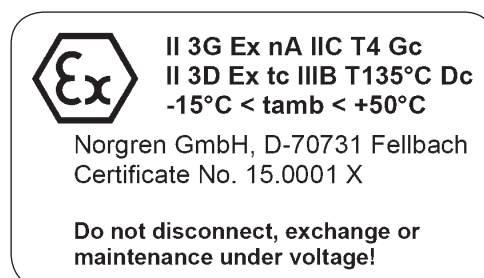

Fieldbus

10.3.3 Specific conditions

The X at the end of the Certificate No. 15.0001 X on the label refers to the following specific conditions:

- The ambient temperature range is between -15°C to +50°C (see operating conditions in section 10.3.1).
- Important: The Device must not be exposed to strong UV light (sunlight)
- Install the device in a suitable approved housing (with IP54 protection minimum) that meets the requirements of EN 60079-15

- The valve island must be used with plugs and cables, which have a conformity evaluation according to Directive 2014/34/EU as well as protection class IP65.
 1. Recommendation: Use plugs or cables from IMI Norgren, which are certified according to Directive 2014/34/EU.
Attention: D-Sub cable for Multipole valve islands, which conforms to all conditions of Directive 2014/34/EU, are **not** available yet. Nevertheless the valve island can be used according to Directive 2014/34/EU (ATEX 137) on the condition defined under „Valve islands with Multipole and Fieldbus D-Sub connector“.
 2. If you are using plugs or cables from another manufacturer, they must have a conformity evaluation according to Directive 2014/34/EU. The combination of the valve island and the plugs/cables used must fulfil the protection class IP65. Use of the plugs/cables from another manufacturer becomes responsibility of the user.

- Valve islands with Fieldbus M12 and 7/8“ round connector:
The valve island must be used in a cabinet or protective box or must be protected against impacts with a protective device (eg. protective fence). This applies above all for the pilot valves and the plastic parts of the valve island.

- Valve islands with Multipole and Fieldbus D-Sub connector:
The valve island must be used in a switch cabinet or protective box, which conforms at least to the protection class IP54. (Attention: Profibus DP with D-Sub connector is not permissible for ATEX.)

- Stress peaks:
The voltage may shortly transcended for not more than 40%. This must be prevented through convenient provisions.
Attention: The permissible voltage range of the valve island is 24V DC +/-10%.

10.3.4 Declaration of conformity

For the declaration of conformity please refer to next pages.

-TRANSLATION-

Norgren GmbH
Postfach 15 60
D-70731 Fellbach
Stuttgarter Straße 120
D-70736 Fellbach

Tel: +49 (0) 711 5209 0
Fax: +49 (0) 711 5209 614
www.imi-precision.com

EU – Declaration of Conformity in accordance with Directive: 2014/34/EU

Equipment: **Valve island of VS18 and VS26 valve series**

Power supply 24V DC
in following designs:

Multipole:	D-Sub connector 9-, 15-, 25-, 44-pin and M23 round connector
Profibus DP	M12 round connector and 7/8" round connector
CANopen	M12 round connector
DeviceNet	M12 round connector



Model series:

Valves: VS18****DF*13E;
 VS26****DF*13E

Sub-bases: VS1872000-**** to VS1872003-****;
 VS1872010-****;
 VS1872200-**** to VS1872206-****;
 VS1872208-**** to VS1872211-****;
 VS1872213-****; VS1872215-****;
 VS1872217-**** to VS1872220-****;
 VS1872222-****; VS182224-****
 VS1872250-**** to VS1872256-****;
 VS2672500-**** to VS2672503-****;
 VS2672510-****; VS2672511-****;
 VS2672700-**** to VS2672706-****;
 VS2672708-**** to VS2672711-****;
 VS2672713-****; VS2672715-****
 VS2672717-**** to VS2672720-****;
 VS2672722-****; VS2672724-****;
 VS2672731-**** to VS2672733-****;
 VS2672735-****; VS2672743-****;
 VS2672750-**** to VS2672756-****

*Engineering
GREAT
Solutions*



Geschäftsführer:
Peter Vanwijk
Christian Kell
Vorsitzender des
Aufsichtsrats:
Thomas Hey

Sitz der Gesellschaft:
46519 Alpen
Handelsregister:
47533 Kleve, HR B 7257
Steuer-Nr.: 5119/5744/0345
USt.- IdNr.: DE191308280

Bankverbindung:
Bank of America N.A.
IBAN: DE88 5001 0900 0020 6340 26
SWIFT-Code: BOFADEFX

-TRANSLATION-

Norgren GmbH
Postfach 15 60
D-70731 Fellbach
Stuttgarter Straße 120
D-70736 Fellbach
Tel: +49 (0) 711 5209 0
Fax: +49 (0) 711 5209 614
www.imi-precision.com

Accessories: VS1872400-***0 to VS1872407-***0;
VS1872428-***0; VS1872429-***0;
VS2672900-***0 to VS2672907-***0;
VS2672910-***0 to VS2672913-***0;
VS2672915-***0 to VS2672917-***0;
VS2672928-***0; VS2672929-***0;
VS2672943-***0 to VS2672945-***0;
V11569-E0*; V11570-E0*;
V11588-E01; V11590-E01 to V11592-E01;
V10009-C00; V70522-K00;
V70523-K00; V70531-KA0

IMI
Precision Engineering

Herewith the manufacturer declares that the named products are in conformity with all relevant provisions of the above mentioned directive to use in potentially explosive atmospheres.

Referenced normative standards:

EN 60079-0:2012	General requirements
EN 60079-15:2010	Type of protection "n"
EN 60079-31:2014	Protection by enclosures "t"

Equipment group, Categories, Types of protection:

 **II 3G Ex nA IIC T4 Gc**
II 3D Ex tc IIIB T135°C Dc

Certificate Number: 15.0001X

Fellbach, September 2016

Norgren GmbH

ppa. 
(Dr. Maik Fiedler)
Engineering Director Continental Europe

i.A: 
(Ulrich Sielemann)
Authorized Representative
German Region

Engineering
GREAT
Solutions

 **IMI NORGREN**

 **IMI BUSCHJOST**

 **IMI FAS**

 **IMI HERION**

 **IMI MAXSEAL**

Geschäftsführer:
Peter Varwijk
Christian Keil
Vorsitzender des
Aufsichtsrats:
Thomas Hey

Sitz der Gesellschaft:
46519 Alpen
Handelsregister:
47533 Kieve, HR B 7257
Steuer-Nr.: 5119/5744/0345
USt.-IdNr.: DE191805280

Bankverbindung:
Bank of America N.A.
IBAN: DE68 5001 0900 0020 6310 26
SWIFT-Code: BOFADE33

11 TRANSPORT / STORAGE / PACKAGING

- VS18/VS26 valve islands and components must be protected against impacts. Valve islands and components delivered by IMI Precision Engineering are protected accordingly.
- VS18/VS26 valve islands and components must be stocked between -15°C and 50°C. If this limit is exceeded, proper function of the components will not be guaranteed.
- VS18/VS26 Fieldbus valve islands contain electronic devices which could be damaged through electrostatic discharge. Therefore electrostatic precautions must be taken. Specifically, the person packaging Fieldbus PCBs must be connected to an earth ground. Fieldbus PCBs delivered by IMI Precision Engineering are accordingly packed and should not be unpacked until the assembly of the valve island. The person assembling or configuring the valve island must be connected to an earth ground.

12 REVISION INDEX

Revision	Date	Revisions	Comments
A	March 2004		
B	July 2004	4.3.1:	Values of 5/2 Sol (priority side 14)/Sol added
		5.1.5:	Section of valve identification labels added
		5.1.10:	5.1.10: Tightening torques of blue coated screws changed
		8.2.1:	D-Sub 9-pin = IP40
		8.3.1:	Pin assignment (Pin 2 + 3) changed
		8.3.8:	Stroke a passage out -> only one EDS file available
		8.4.1:	Pin assignment (Pin 2 + 3) changed
		8.4.3:	Address settings changed
		8.4.8:	Stroke a passage out -> only one EDS file available
		8.5.1:	D-Sub 9-pin = IP65, Pin assignment Female (Pin 5 + 9) changed
		8.6.3:	Default addresses added
		8.6.6:	Setting of DIP switches of configuration switch changed
		10.3.4:	Declaration of conformity available and added
		11:	Information added
			Div.: Added note concerning correspondence of part number and valve island configuration when changing valves or accessories
			Div.: Tightening torques in lbs added (only in English version)
C	February 2005	7.3.1:	New design: drawings and screw types changed, screw driver speed corrected
		7.4:	Variant with M23 connector added
		8.1.5	Assembly of FD67 bus added
		8.3.1, 8.4.1:	Pin assignment of power connector added
		8.5.7:	Interbus-S ID and length codes changed
		8.7	Section of FD67 bus added
D	June 2005	4.2:	Material of some VS sandwich plate bodies changed from die cast aluminium to moulded plastic
		4.3.1, 4.3.2:	Data of 2 x 2/2 valves added
		5.1.4, 5.1.10, 5.1.11, 5.2.2, 9.2:	Use of U-washers is no longer necessary
		8.7, 8.7.5	CANopen added
		8.7.1	Information of I _{max} corrected
		8.7.6, 8.7.7	Information adjusted
		8.7.8	Section added
E	May 2007	4.3.5, 4.5.6, 4.5.7, 5.1.14, 8.7.10:	Section added
		4.4.3, 6.1.1, 7.1.1, 8.1.1:	"UL Class 2 Supply only" added
		5.1.2:	Text "Valve mounting screws" added
		5.1.4, 5.1.11, 9.2:	Tightening torque of valve mounting screws adjusted
		5.1.10:	Exchange of valve mounting screws no longer necessary
		5.1.4, 5.1.10, 5.1.11, 5.2.2, 9.2:	Use of U-washers for VS26 still necessary
		5.2.2:	Spare part no of valve mounting screws adjusted
		7.1, 7.2:	Information about max. no of valve stations adjusted
		7.2.2:	Footnote at 44-pin assignment added
		8:	Section about AB RIO deleted, AB RIO is no more available
		8.2.4:	Default setting of configured output bytes specified
		8.3.1, 8.4.1:	Pin assignments adjusted
F	December 2015		Data sheets numbers changed from 5.4.159 to 5.1.250; from 5.4.160 to 5.1.350
		4.5.2:	ATEX standard changed
		4.5.7:	CSA deleted; UL limited operation for USA market
		5.2.2:	Part numbers for mounting screw for VS18 and VS26 valves changed
		6:	Illustration of Single station sub-base added
		8:	Section about FD67 bus deleted, FD67 bus is no longer available
		10.3.1:	Maximal Power consumption allowed added
		10.3.2:	Labels changed
		10.3.3:	Location of X marking changed; Protection about sunlight and storing in IP54 cabinet added
G	August 2016		
		4.5.2, 10:	ATEX standard updated
		5.1.10:	Mounting instruction for VS18 sandwich plate changed
		5.1.11:	Tightening torque for VS18 valve onto Sub-base changed
		5.2.2:	Spare parts for VS18/VS26 valves extended
H	September 2016		
		9.2:	tightening torque for VS18 valve onto Sub-base change
		10:	Fieldbus protocols for ATEX CANopen, DeviceNet for non-conducted dust extended
		10.3.2:	Labels Extend

Norgren GmbH, Site Fellbach
IMI Precision Engineering

Stuttgarter Straße 120
D-70736 Fellbach
Tel.: +49 7 11 52 09-0
Fax: +49 7 11 - 52 09-6 14

The data specified above only serve to describe the product. No statements concerning a certain condition or suitability for a certain application can be derived from our information. The given information does not release the user from the obligation of own judgement and verification. It must be remembered that our products are subject to a natural process of wear and ageing.

© This document, as well as the data, specifications and other information set forth in it, are the exclusive property of Norgren GmbH. Without their consent it may not be reproduced or given to third parties.

Subject to modifications.
These instructions were originally generated in German.
Order no: **VS2672926-KG00**
EN
Revision: H