



P1X Series Compact Rodless Air Cylinders

Catalog 0975

aerospace
climate control
electromechanical
filtration
fluid & gas handling
hydraulics
pneumatics
process control
sealing & shielding



ENGINEERING YOUR SUCCESS.

Features and Benefits	3
Ordering Information.....	4
Specifications, Weights and Forces.....	5
Technical Data.....	6-9
Sensor Adapter Bracket.....	10
Basic Dimensions.....	10-11
Mounting Bracket Dimensions.....	12-14
Accessories & Options	15-16
End Port Piping.....	16
Shock Absorbers	17-19
Stroke Adjustment Unit.....	20-21
Electronic Sensors.....	22-24
Safety Guide.....	25-26
Offer of Sale	27

⚠ WARNING

FAILURE OR IMPROPER SELECTION OR IMPROPER USE OF THE PRODUCTS AND/OR SYSTEMS DESCRIBED HEREIN OR RELATED ITEMS CAN CAUSE DEATH, PERSONAL INJURY AND PROPERTY DAMAGE.

This document and other information from Parker Hannifin Corporation, its subsidiaries and authorized distributors provide product and/or system options for further investigation by users having technical expertise. It is important that you analyze all aspects of your application including consequences of any failure, and review the information concerning the product or system in the current product catalog. Due to the variety of operating conditions and applications for these products or systems, the user, through its own analysis and testing, is solely responsible for making the final selection of the products and systems and assuring that all performance, safety and warning requirements of the application are met.

The products described herein, including without limitation, product features, specifications, designs, availability and pricing, are subject to change by Parker Hannifin Corporation and its subsidiaries at any time without notice.

Offer of Sale

The items described in this document are hereby offered for sale by Parker Hannifin Corporation, its subsidiaries or its authorized distributors. This offer and its acceptance are governed by the provisions stated on the separate page of this document entitled "Offer of Sale".

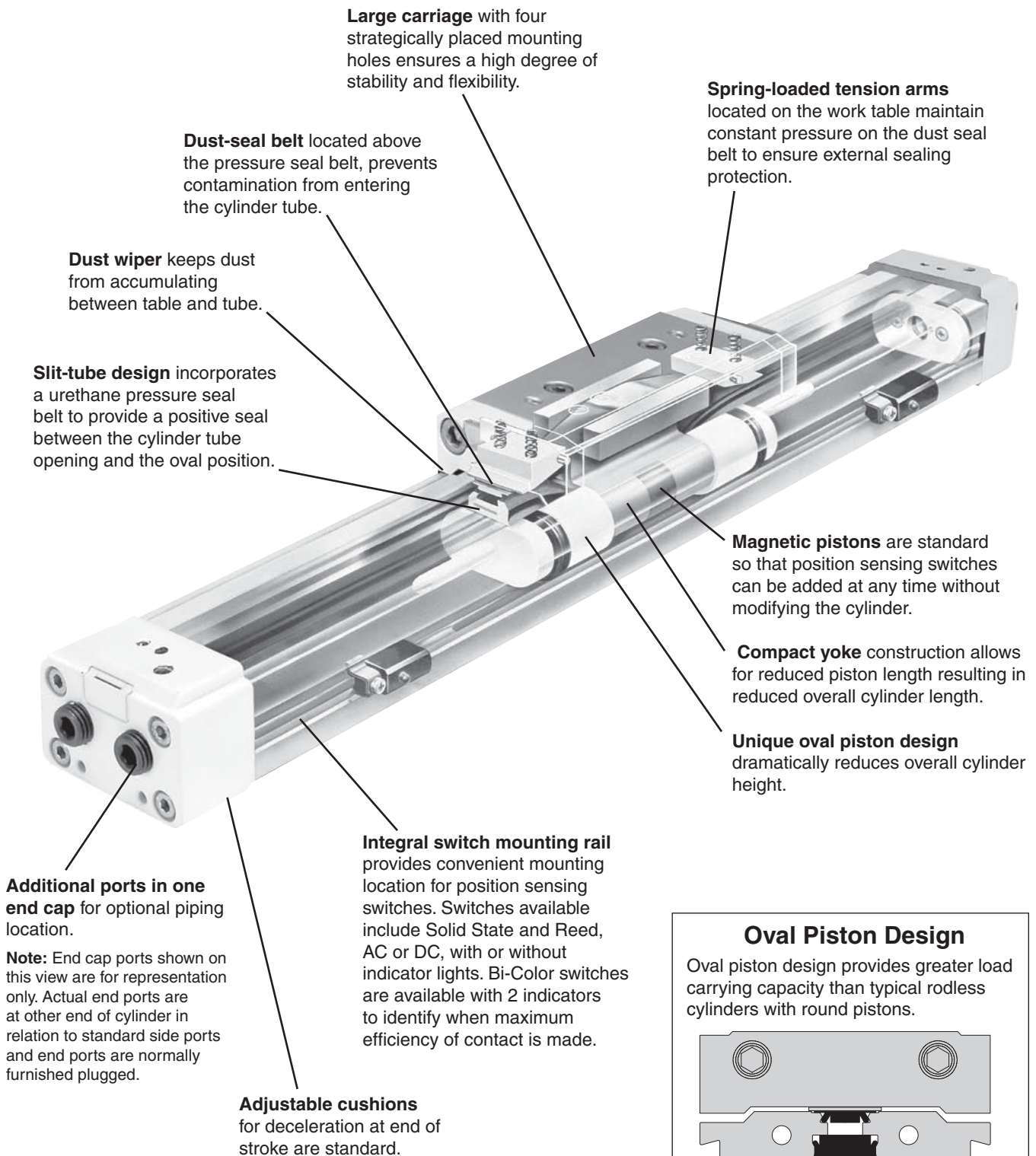

Oval Piston Design

Oval piston design provides greater load carrying capacity than typical rodless cylinders with round pistons.

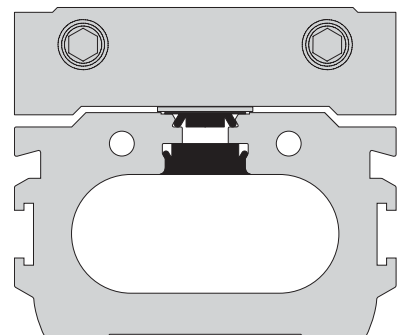

Model Code

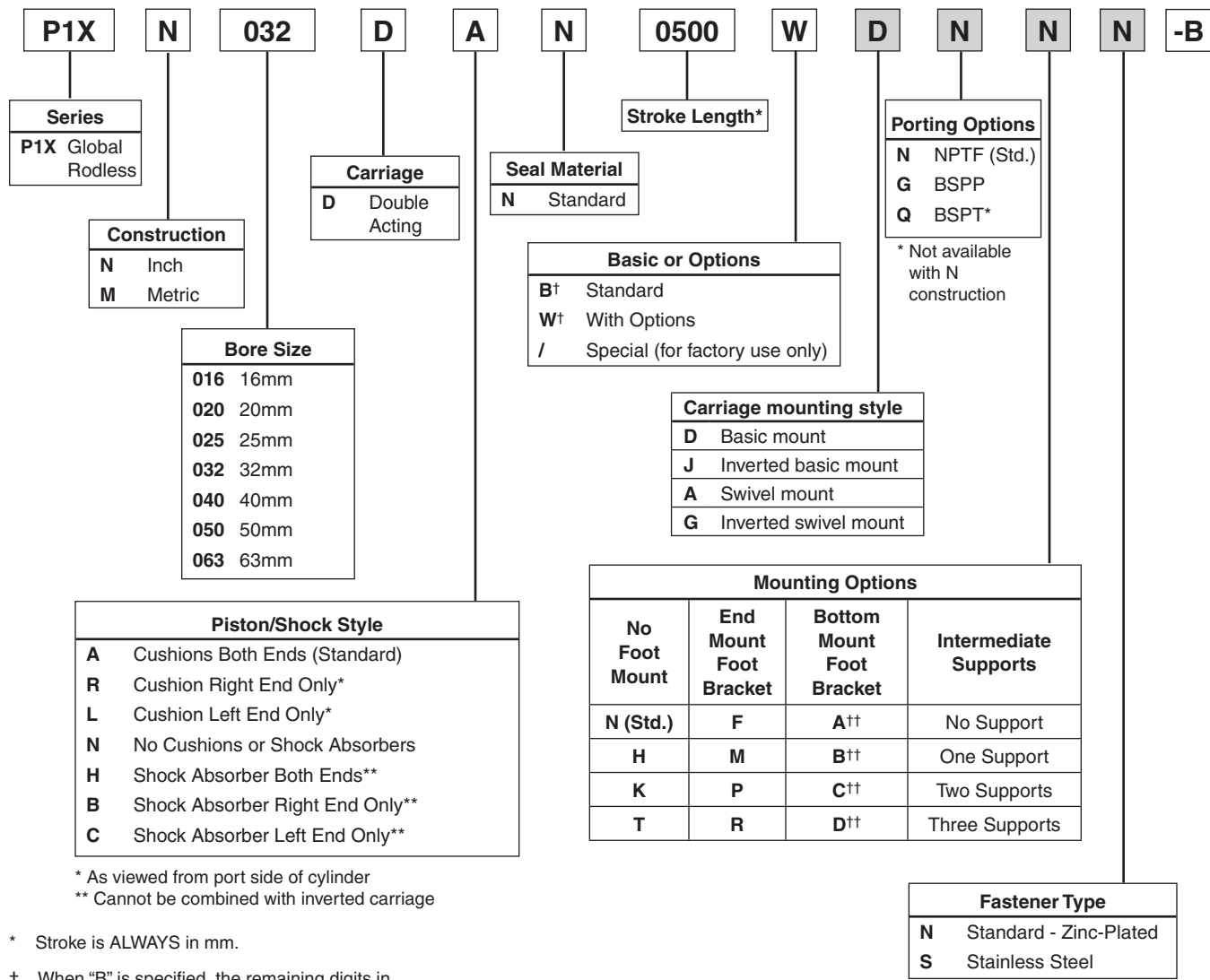

* As viewed from port side of cylinder
 ** Cannot be combined with inverted carriage

* Stroke is ALWAYS in mm.

† When "B" is specified, the remaining digits in the part number are not necessary. If "W" is used, the remaining digits in the part number must be filled out.

†† Not available on 40, 50 and 63mm bore sizes.

Essential Information
 Optional Features

Sensor Selection Guide

Bore Size or Type	3m Flying Leads	10m Flying Leads	8mm Quick Connect*	8mm Quick Connect w/ 1 m Lead*	12mm Quick Connect*	Bracket
PNP Solid State Sensor						
All	P8S-GPFLX	P8S-GPFTX	P8S-GPSHX	P8S-GPSCX	P8S-GPMHX	P8S-TMA0Y
NPN Solid State Sensor						
All	P8S-GNFLX	P8S-GNFTX	P8S-GNSHX	P8S-GNSCX	P8S-GNMHX	P8S-TMA0Y
Reed Sensor						
All	P8S-GRFLX	P8S-GRFTX	P8S-GRSHX	P8S-GRSCX	P8S-GRMHX	P8S-TMA0Y

Specifications

Model	P1X (Standard w/Switch)			
Operating Medium	Compressed Air			
Maximum Pressure	100 PSI (7 BAR)			
Minimum Pressure	Ø16, Ø20 Bores 29 PSI (2 Bar) Ø25, Ø32, Ø40 Bores 14.5 PSI (1 Bar) Ø50, Ø63 Bores 7 PSI (0.5 Bar)			
Proof Pressure	152 PSI (10.5 Bar)			
Bore Size mm (inch nominal)	16 (5/8)	20 (3/4), 25 (1)	32 (1-1/4), 40 (1-1/2)	50 (2), 63 (2 1/2)
Port Size – N Series	M5 (10-32)	1/8 NPT	1/4 NPT	3/8 NPT
Port Size – M Series	M5 (10-32)	1/8 Rc	1/4 Rc	3/8 Rc
Ambient Temperature °F (°C)	40 to 140°F (5 to 60°C)			
Stroke Tolerance in.	±0.080 to 39"	±0.100 to 118"	±0.120 to 196"	
Piston Speed, *in./sec.	2-80 IPS with side ports on each end (Ø16 & Ø20 bores 2-40 IPS with single end porting with 39" stroke) (Ø25, Ø32, Ø40, Ø50 & Ø63 bores 2-40 IPS with single end porting with 78" stroke)			
Cushion	Air Cushion Standard			
Lubrication	Not Required (if you choose to lubricate your system, continuing lubrication will be required.)			

*Note: Actual piston speed with one end ports will vary depending on stroke length.

Weight & Theoretical Force Characteristics

Bore	Area In ²	Weights								Theoretical Force (lbs)				
		Weight at Zero Stroke						Weight per 1" (25.4mm) Stroke		at Pressure (PSI)				
		M00		MLB		MLB1		lbs	kg	30	40	60	80	100
		lbs	kg	lbs	kg	lbs	kg							
16	0.31	0.70	0.3	0.73	0.3	0.77	0.4	0.07	0.03	9	12	19	25	31
20	0.49	1.15	0.5	1.19	0.5	1.28	0.6	0.10	0.04	15	20	29	39	49
25	0.84	2.21	1.0	2.43	1.1	2.43	1.1	0.15	0.07	23	30	46	61	76
32	1.26	3.31	1.5	3.53	1.6	3.75	1.7	0.20	0.09	38	50	69	100	125
40	1.96	5.29	2.4	5.51	2.5	—		0.27	0.12	59	78	117	156	195
50	3.08	7.94	3.6	8.16	3.7			0.40	0.18	91	122	182	243	304
63	4.86	13.67	6.2	14.33	6.5			0.63	0.28	145	193	290	386	483

Replacement Seal Kits

Bore (mm)	Part Number
16	L079020016
20	L079020020
25	L080100025
32	L080100032
40	L080100040
50	L080100050
63	L080100063

Moments

Figure 5 shows the maximum allowable moments for each of the three types of loading: pitch, roll and yaw.

The sum total of each of these types of moments, divided by each of the maximum values, determines a Load-Moment Factor (LMF) should be equal to or less than 1.0. On horizontal mountings, the total load (L) should also be divided by the maximum load allowable (Figure 6) and factored into the equation.

Horizontal Mountings:

$$\frac{L}{[L]} + \frac{M}{[M]} + \frac{M_s}{[M_s]} + \frac{M_v}{[M_v]} = LMF \leq 1.0$$

Vertical Mountings:

$$\frac{M}{[M]} + \frac{M_s}{[M_s]} + \frac{M_v}{[M_v]} = LMF \leq 1.0$$

Figure 5

Bore	Maximum Allowable Moments N-m (lb-in)					
	[M] Pitch Moment		[Ms] Roll Moment		[Mv] Yaw Moment	
	Std.	Inverted	Std.	Inverted	Std.	Inverted
	16	5 (44)	3.5 (31)	1 (9)	0.5 (4)	1 (9)
20	10 (89)	7 (62)	1.5 (13)	0.7 (6)	3 (27)	3 (27)
25	17 (150)	12 (106)	5 (44)	2.5 (22)	10 (89)	10 (89)
32	36 (319)	25 (221)	10 (89)	5 (44)	21 (186)	21 (186)
40	77 (682)	54 (478)	23 (204)	11.5 (102)	26 (230)	26 (230)
50	154 (1363)	108 (956)	32 (283)	16 (142)	42 (372)	42 (372)
63	275 (2434)	193 (1708)	52 (460)	26 (230)	76 (673)	76 (673)

Load and Deflection

Figure 6 shows the maximum load [L] that the cylinder can accept, as well as the maximum length [D] between supports at the maximum load.

Horizontal—Load Above

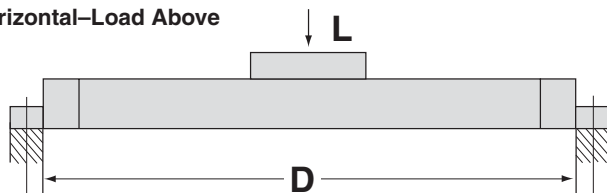

Horizontal—Load Below

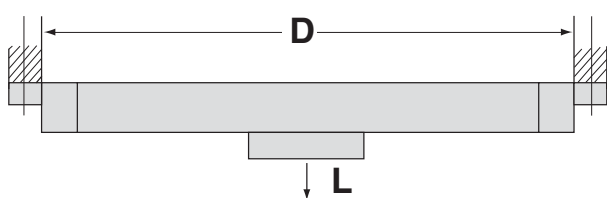

Horizontal—Tube Support

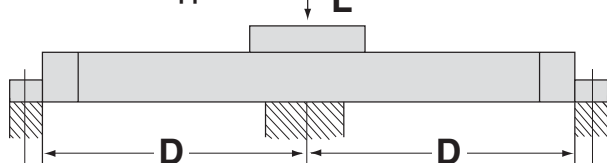
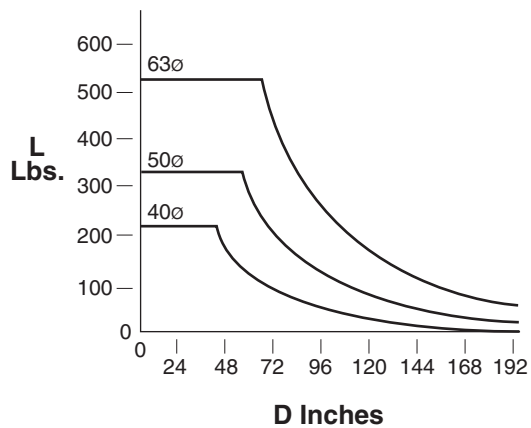
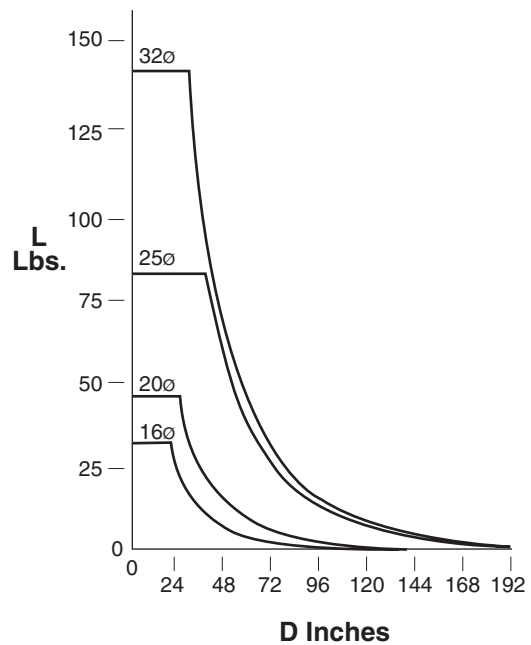

Figure 6

Bore Size	Max. Allowable Load [L] N (lbs)		Max. Unsupported Length mm (in) at Max. Load
	Std.	Inverted	
16	141 (32)	70 (16)	450 (17.7)
20	198 (45)	101 (23)	551 (21.7)
25	356 (81)	180 (41)	899 (35.4)
32	616 (140)	308 (70)	749 (29.5)
40	959 (218)	480 (109)	1000 (39.4)
50	1456 (331)	726 (165)	1300 (51.2)
63	2297 (522)	1148 (261)	1600 (63.0)

Acceptable length and load combinations for the various bore sizes can be determined from the charts in Figure 7.

Figure 7



To determine cylinder deflections under the load (or resistive force perpendicular to the piston table) without mid-support, see the graphs on page G135.

Inertia Moment Consideration

When the weight is stopped at the end of the stroke by the cylinder cushion, inertial force is created. This inertial force (Fi) can be determined by using the formula:

Fi = LG

L = Load attached to the cylinder carriage (lbs.)

G = Inertia factor (Figure 8)

Example:

A speed of 40 in/sec corresponds to an inertia factor G of 13.

The inertial force calculated would then be multiplied by the distance from the center of gravity of the load to the centerline of the cylinder, and added to the previously calculated M and Mv moments. This will give an M Total and Mv Total. Ensure that the M Total and the Mv Total do not exceed the [M] and [Mv] values shown in Figure 5 (previous page). If they exceed these values, consult the factory.

See pages G144-G146 for additional information on shock absorbers.

Figure 8

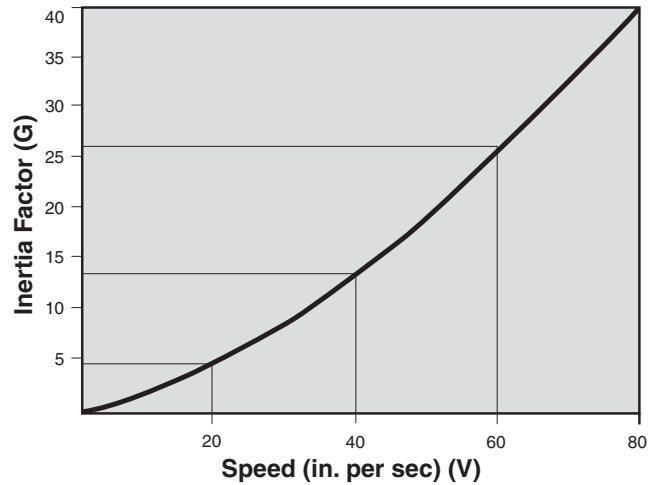

External Stops

When the load attached to the cylinder is stopped externally, it creates an additional moment equal to the cylinder force (Fa) times the distance (S). This additional moment, plus the previously calculated Load-Moment factor, should not exceed the allowable values. See previous page.

When reducing the stroke with external stops, remember that the cushion length and the energy absorption capacity are not directly proportional. Reducing the cushioning distance by 50% corresponds to a reduction of 60-70% in cushion effectiveness.

Figure 9

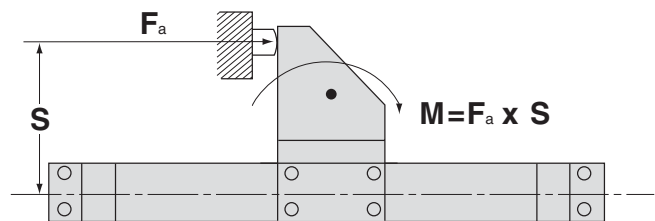

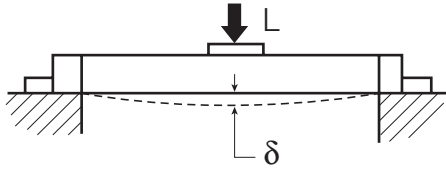

16 mm Bore

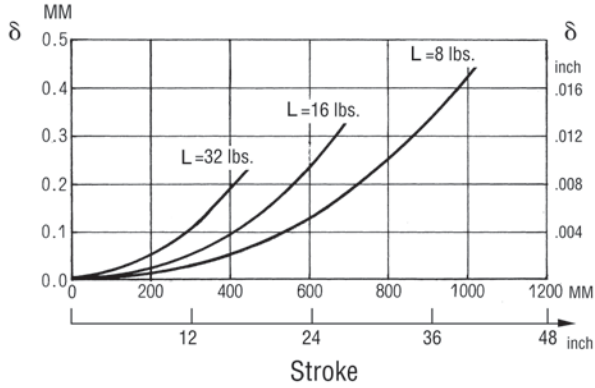

20 mm Bore

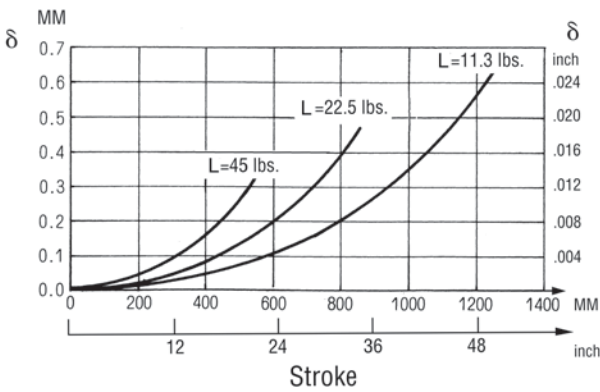

25 mm Bore

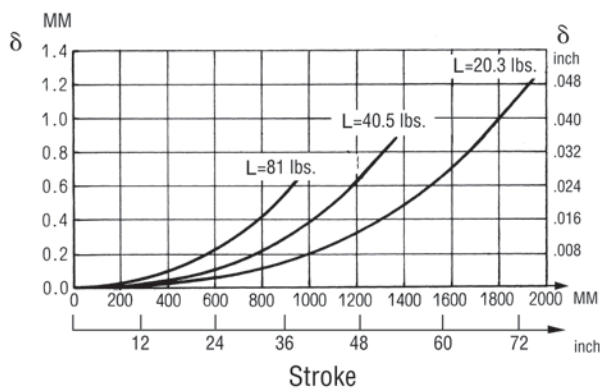

32 mm Bore

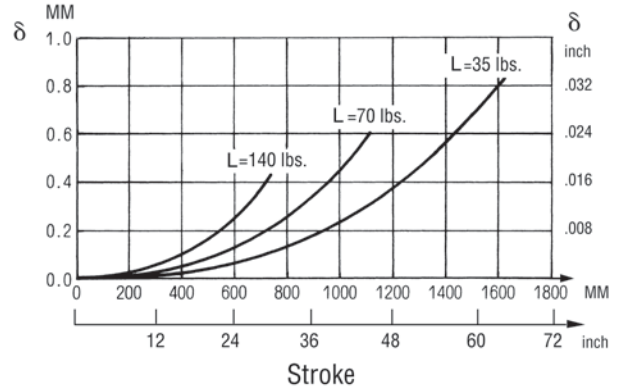

40 mm Bore

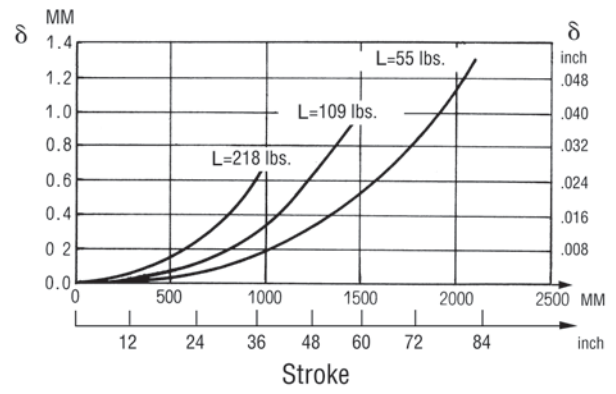

50 mm Bore

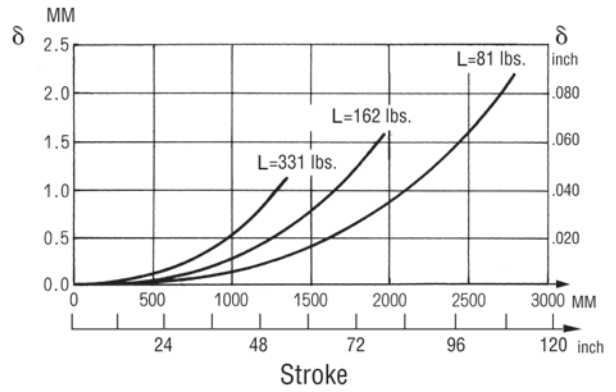

63 mm Bore

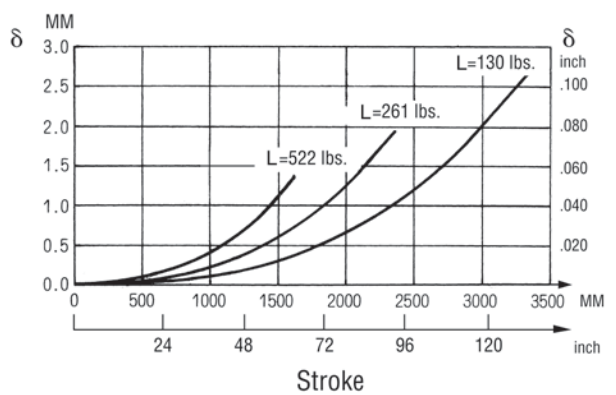

Piston Table Angular Deflection Due To Load Moments Applied

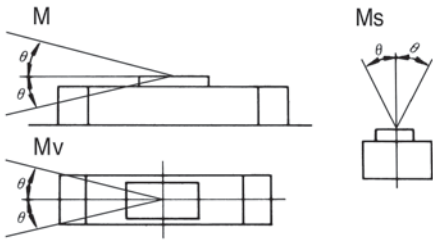

16 mm Bore

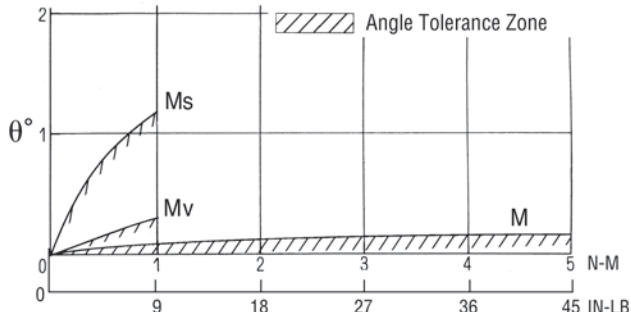

20 mm Bore

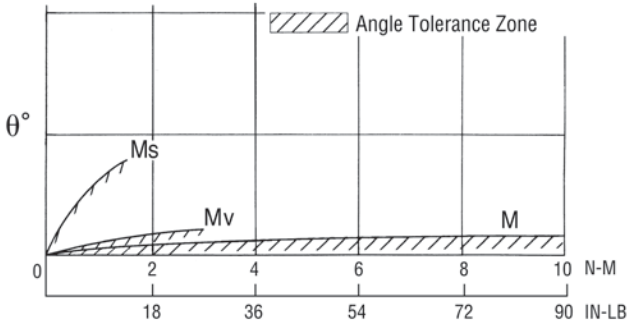

25 mm Bore

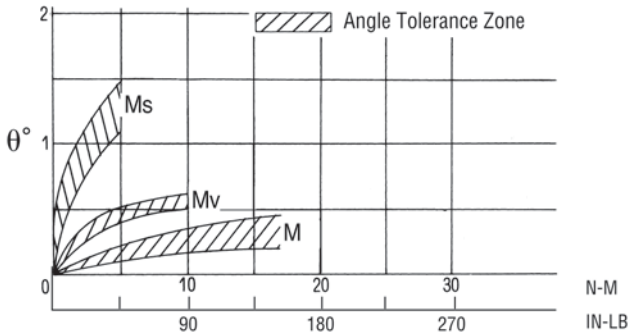

32 mm Bore

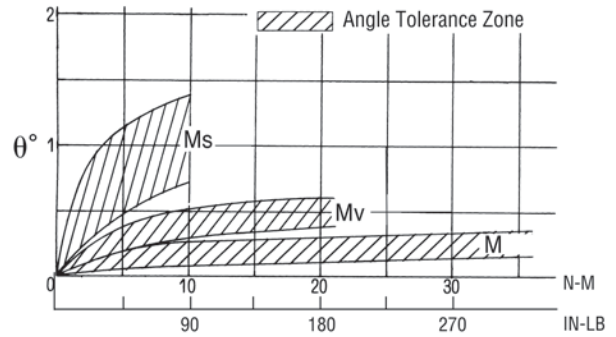

40 mm Bore

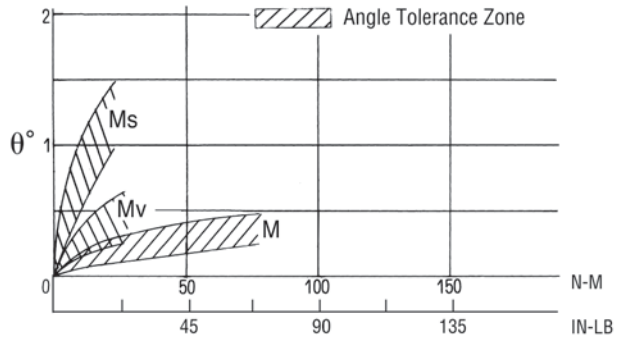

50 mm Bore

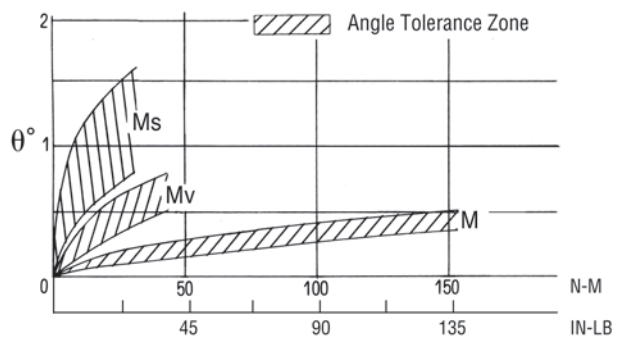

63 mm Bore

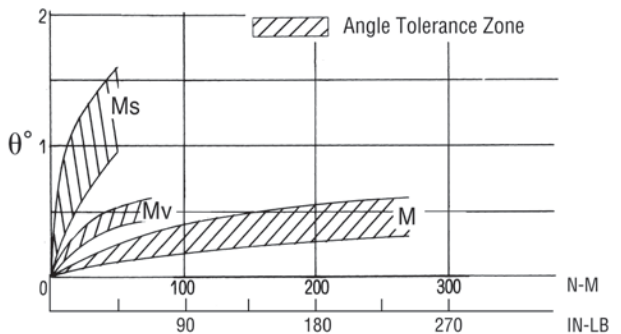

Basic Cylinder

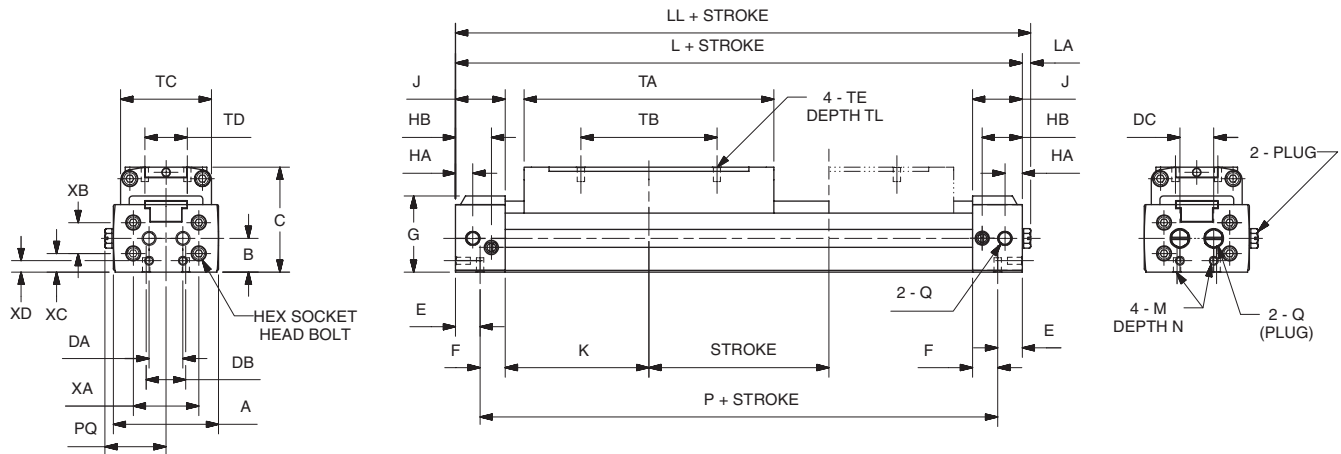

Bore (mm)		A	B	C	DA	DB	DC	E	F	G	HA	HB	J	K	L	LL	LA	M	N
16	inches	1.46	0.47	1.46	0.47	0.55	0.47	0.34	0.35	1.06	0.24	0.55	0.69	2.24	5.87	5.98	0.12	5-40	0.20
	mm	37	12	37	12	14	12	8.5	9	27	6	14	17.5	57	149	152	3	M3	5
20	inches	1.73	0.55	1.65	0.55	0.63	0.63	0.41	0.45	1.22	0.34	0.73	0.87	2.46	6.65	6.75	0.10	8-32	0.26
	mm	44	14	42	14	16	16	10.5	11.5	31	8.5	18.5	22	62.5	169	171.5	2.5	M4	6.5

Bore (mm)		P	PQ	Q	TA	TB	TC	TD	TE	TL	XA	XB	XC	XD
16	inches	5.20	0.83	10-32 NPT	3.47	1.89	1.26	0.59	5-40	0.20	0.91	0.43	0.26	0.16
	mm	132	21	M5	88	48	32	15	M3	5	23	11	6.5	4
20	inches	5.83	0.97	1/8 NPT	3.94	2.36	1.50	0.71	8-32	0.24	1.10	0.63	0.24	0.20
	mm	148	24.5	1/8 Rc	100	60	38	18	M4	6	28	16	6	5

Sensor Adapter Bracket

Part Number P8S-TMA0Y
 (Shown larger than actual size)

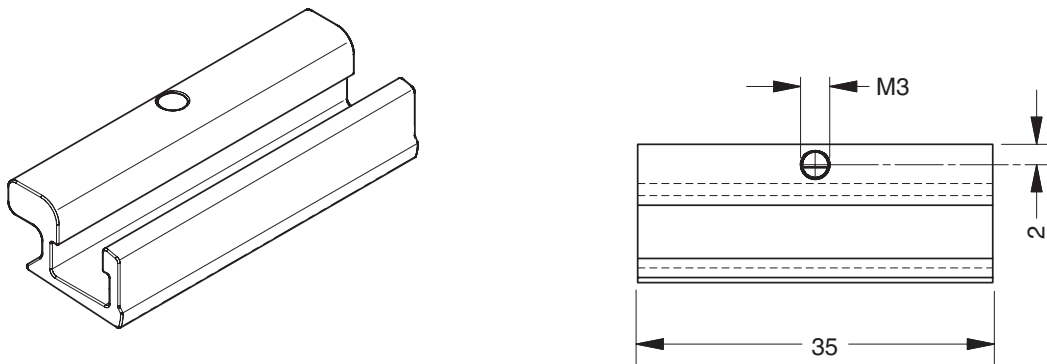

NOTE: Must be ordered separately when ordering sensors.
 for sensor information, please see Section M.

Basic Cylinder

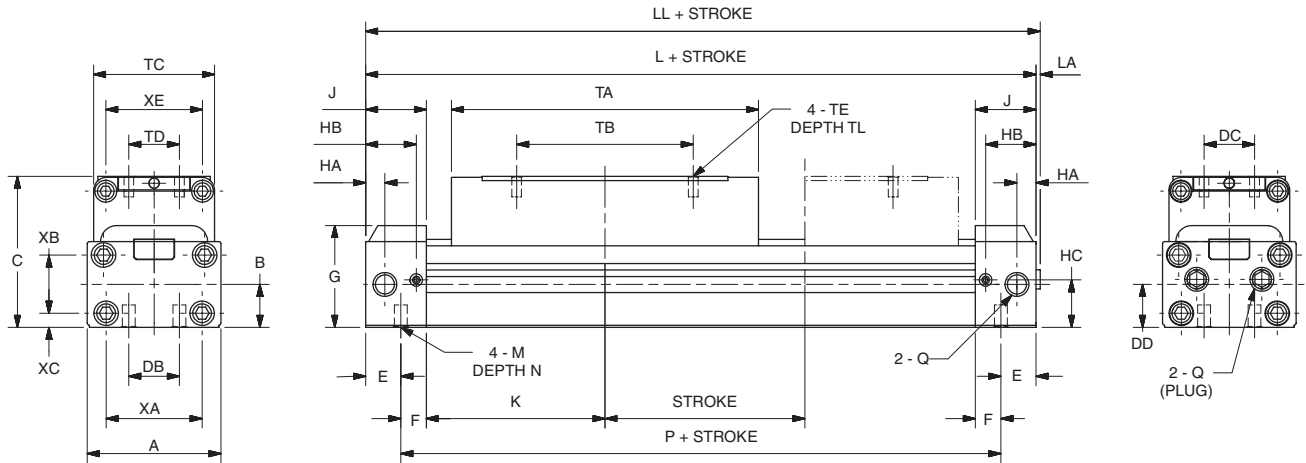

Bore (mm)	A	B	C	DB	DC	DD	E	F	G	HA	HB	HC	J	K	L	LL	LA	M	N
25	inches	2.09	0.67	2.09	0.79	1.02	0.75	0.39	1.59	0.30	0.79	0.74	0.95	2.80	7.48	7.56	0.08	1/4-20	0.35
	mm	53	17	53	20	26	19	10	40.5	7.5	20	18.9	24	71	190	192	2	M6	9
32	inches	2.60	0.73	2.24	1.26	1.06	0.83	0.51	1.71	0.39	0.93	0.85	1.10	3.35	8.90	9.00	0.10	1/4-20	0.35
	mm	66	18.5	57	32	27	21	15	43.5	10	23.5	21.5	28	85	226	228.5	2.5	M6	9
40	inches	3.15	0.87	2.64	1.42	1.38	1.10	0.67	2.03	0.51	1.02	1.06	1.22	3.58	9.61	9.71	0.10	5/16-18	0.47
	mm	80	22	67	36	35	28	17	51.5	13	26	27	31	91	244	246.5	2.5	M8	12
50	inches	3.78	1.10	3.23	1.77	1.38	1.38	0.91	2.40	0.59	1.30	1.39	1.54	3.54	10.16	10.26	0.10	5/16-18	0.47
	mm	96	28	82	45	35	35	23	61	15	33	35.3	39	90	258	260.5	2.5	M8	12
63	inches	4.65	1.38	3.74	1.97	1.54	1.65	0.75	2.91	0.59	1.26	1.69	1.54	4.29	11.65	11.75	0.10	3/8-16	0.59
	mm	118	35	95	50	39	42	19	74	15	32	43	39	109	296	298.5	2.5	M10	15

Bore (mm)	P	Q	TA	TB	TC	TD	TE	TL	XA	XB	XC	XE
25	inches	6.38	1/8 NPT	4.80	2.76	1.89	0.79	10-24	0.32	1.50	0.91	1.58
	mm	162	1/8 Rc	122	70	48	20	M5	8	38	23	40
32	inches	7.72	1/4 NPT	5.28	3.15	2.21	0.79	1/4-20	0.35	1.89	0.98	1.85
	mm	196	1/4 Rc	134	80	56	20	M6	9	48	25	47
40	inches	8.27	1/4 NPT	5.83	3.54	2.68	1.18	1/4-20	0.43	2.36	1.18	2.28
	mm	210	1/4 Rc	148	90	68	30	M6	11	60	30	58
50	inches	8.35	3/8 NPT	5.98	3.94	3.15	1.18	5/16-18	0.51	2.91	1.42	2.76
	mm	212	3/8 Rc	152	100	80	30	M8	13	74	36	70
63	inches	10.16	3/8 NPT	6.61	4.33	4.02	1.58	5/16-18	0.51	3.78	1.65	3.54
	mm	258	3/8 Rc	168	110	102	40	M8	13	96	42	90



16-32 mm Bore Sizes

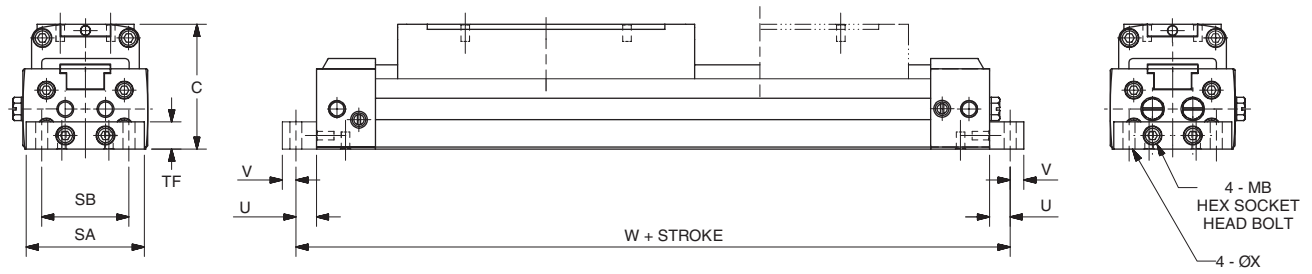

See page G133 for end port usage.

40-63 mm Bore Sizes

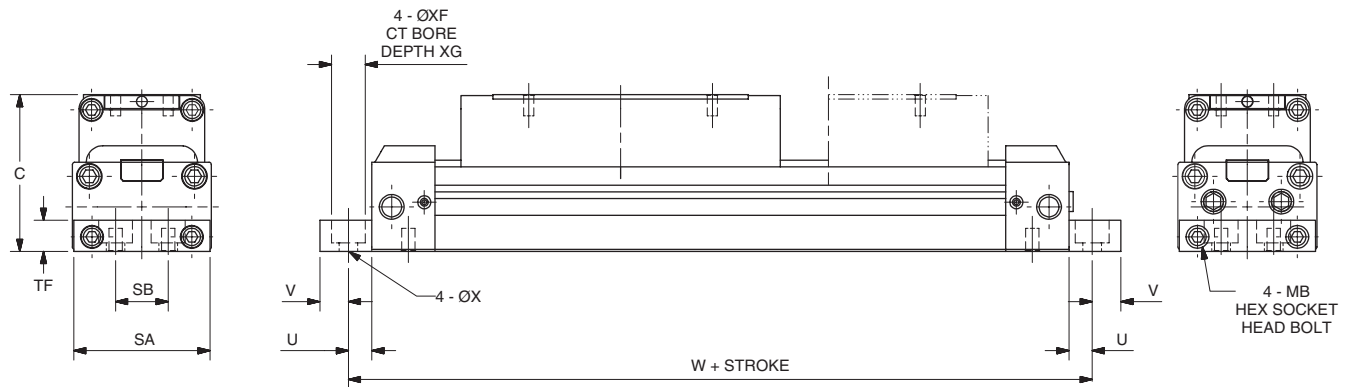

See page G133 for end port usage.

Bore (mm)		C	SA	SB	TF	U	V	W	X	XF	XG	MB
16	inches	1.46	1.38	1.02	0.32	0.24	0.16	6.34	0.14			-
	mm	37	35	26	8	6	4	161	3.6			M3x10
20	inches	1.65	1.69	1.30	0.39	0.24	0.24	7.13	0.19			-
	mm	42	43	33	10	6	6	181	4.7			M4x12
25	inches	2.09	2.05	0.79	0.47	0.35	0.43	8.19	0.28			
	mm	53	52	20	12	9	11	208	7			M5x50
32	inches	2.24	2.52	1.26	0.47	0.35	0.43	9.61	0.28			
	mm	57	64	32	12	9	11	244	7	M5x50		
40	inches	2.64	3.15	1.18	0.59	0.49	0.45	10.60	0.35	0.51	0.34	
	mm	67	80	30	15	12.5	11.5	269	9	13	8.7	M6x55
50	inches	3.23	3.70	1.57	0.79	0.49	0.45	11.10	0.35	0.51	0.34	
	mm	82	94	40	20	12.5	11.5	283	9	13	8.7	M8x65
63	inches	3.74	4.57	1.89	0.98	0.59	0.59	12.80	0.43	0.61	0.41	
	mm	95	116	48	25	15	15	326	11	15.5	10.5	M8x70

16-20 mm Bore Sizes

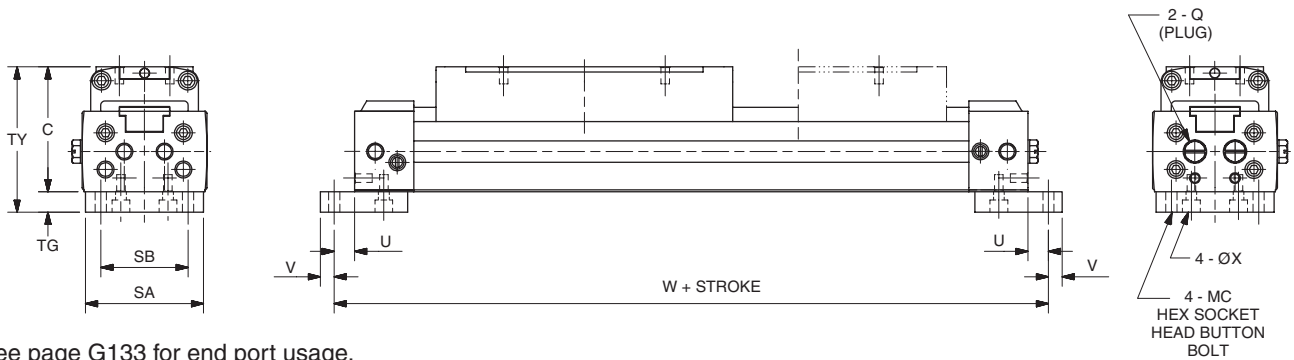

See page G133 for end port usage.

25-32 mm Bore Sizes

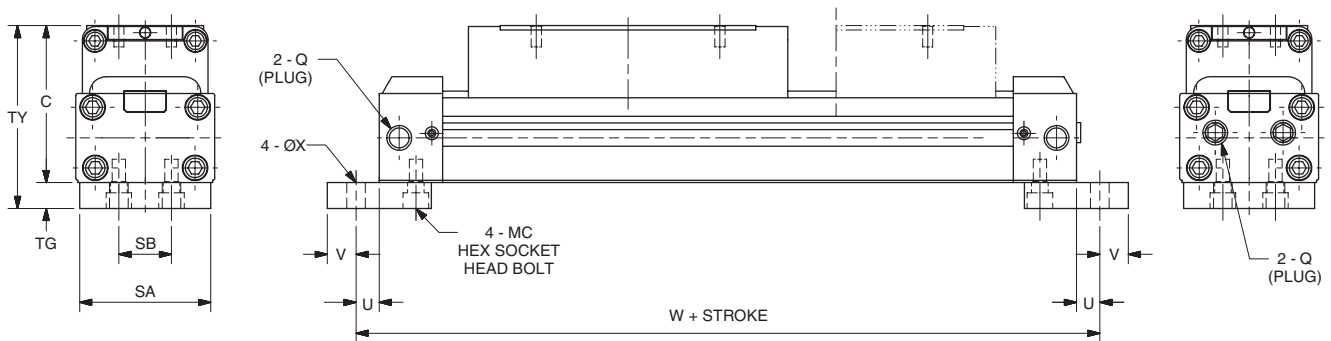

See page G133 for end port usage.

Bore (mm)		C	Q	SA	SB	TG	TY	U	V	W	X	MC
16	inches	1.46	10-32	1.38	1.02	0.24	1.69	0.24	0.16	6.34	0.13	5-40, 1/4 LG
	mm	37	M5	35	26	6	43	6	4	161	3.4	
20	inches	1.65	1/8 NPT	1.69	1.30	0.32	1.97	0.24	0.24	7.13	0.18	8-32, 3/8 LG
	mm	42	1/8 Rc	43	33	8	50	6	6	181	4.5	
25	inches	2.09	1/8 NPT	1.97	0.79	0.39	2.48	0.35	0.43	8.19	0.28	1/4-20 x 1/2 LG
	mm	53	1/8 Rc	50	20	10	63	9	11	208	7	
32	inches	2.24	1/4 NPT	2.52	1.26	0.39	2.64	0.35	0.43	9.61	0.28	1/4-20 x 1/2 LG
	mm	57	1/4 Rc	64	32	10	67	9	11	244	7	
40	inches	2.64	1/4 NPT									
	mm	67	1/4 Rc									
50	inches	3.23	3/8 NPT									
	mm	82	3/8 Rc									
63	inches	3.74	3/8 NPT									
	mm	95	3/8 Rc									

Intermediate Support Brackets

End Mount

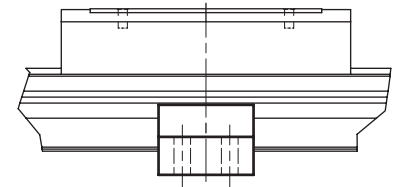
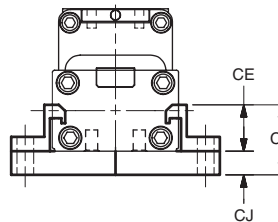
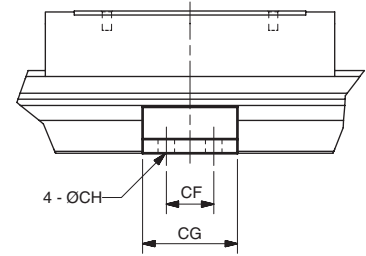
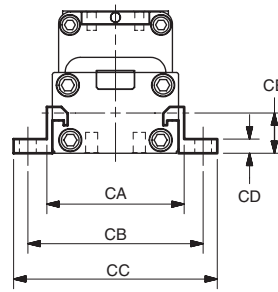
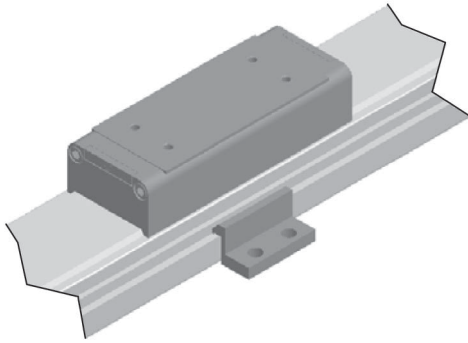

Intermediate Support Brackets (2 per kit)

Bore		CA	CB	CC	CD	CE	CF	CG	CH
16 mm	inches	1.654	2.205	2.52	0.118	0.472	0.787	1.378	0.157
	mm	42	56	64	3	12	20	35	4
20 mm	inches	1.929	2.52	2.953	0.157	0.551	0.787	1.496	0.197
	mm	49	64	75	4	14	20	38	5
25 mm	inches	2.362	2.992	3.465	0.236	0.768	0.787	1.575	0.276
	mm	60	76	88	6	19.5	20	40	7
32 mm	inches	2.913	3.465	3.937	0.236	0.846	0.787	1.575	0.276
	mm	74	88	100	6	21.5	20	40	7
40 mm	inches	3.543	4.252	4.882	0.236	0.965	1.181	2.362	0.354
	mm	90	108	124	6	24.5	30	60	9
50 mm	inches	4.173	4.882	5.512	0.315	1.201	1.181	2.362	0.354
	mm	106	124	140	8	30.5	30	60	9
63 mm	inches	5.118	5.984	6.772	0.394	1.516	1.969	3.543	0.433
	mm	130	152	172	10	38.5	50	90	11

Bore		CJ	CK	Kit Part Number	
				End Mount or No Mount	Bottom Mount
16 mm	inches	0.236	0.709	L080180016	L080190016
	mm	6	18		
20 mm	inches	0.315	0.866	L080180020	L080190020
	mm	8	22		
25 mm	inches	0.394	1.161	L080180025	L080190025
	mm	10	29.5		
32 mm	inches	0.394	1.24	L080180032	L080190032
	mm	10	31.5		
40 mm	inches	—	—	L080180040	—
	mm				
50 mm	inches				
	mm				
63 mm	inches				
	mm				

Swivel Mount

Absorbs misalignment between cylinder and load

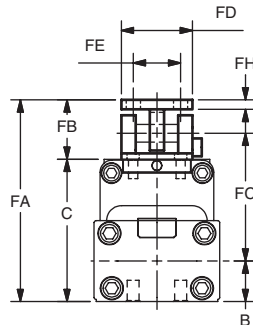
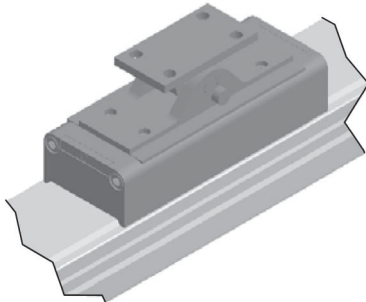

FJ dimension is the maximum horizontal float

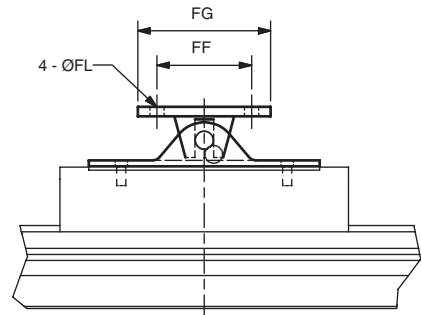

FK dimension is the maximum vertical float

Swivel Mounts

Bore		FA	FB	FC	FD	FE	FF	FG	FH
16 mm	inches	2.238	0.827	1.339	0.945	0.673	1.181	1.575	0.118
	mm	58	21	34	24	16	30	40	3
20 mm	inches	2.638	0.984	1.535	1.181	0.787	1.575	2.205	0.157
	mm	67	25	39	30	20	40	56	4
25 mm	inches	3.071	0.984	1.85	1.181	0.787	1.575	2.205	0.157
	mm	78	25	47	30	20	40	56	4
32 mm	inches	3.74	1.496	2.185	1.772	1.181	1.969	2.756	0.236
	mm	95	38	55.5	45	30	50	70	6
40 mm	inches	4.134	1.496	2.441	1.772	1.181	1.969	2.756	0.236
	mm	105	38	62	45	30	50	70	6
50 mm	inches	4.961	1.732	2.874	2.362	1.575	2.756	3.543	0.315
	mm	126	44	73	60	40	70	90	8
63 mm	inches	5.472	1.732	3.11	2.362	1.575	2.756	3.543	0.315
	mm	139	44	79	60	40	70	90	8

Bore		FJ	FK	FL	B	C	Part Number
16 mm	inches	0.118	0.118	0.134	0.472	1.457	L078930016
	mm	3	3	3.4	12	37	
20 mm	inches	0.118	0.118	0.177	0.551	1.654	L080160020
	mm	3	3	4.5	14	42	L08016M020
25 mm	inches	0.118	0.118	0.236	0.669	2.087	L080160025
	mm	3	3	6	17	53	L08016M025
32 mm	inches	0.197	0.197	0.276	0.728	2.244	L080160032
	mm	5	5	7	18.5	57	L08016M032
40 mm	inches	0.197	0.197	0.276	0.866	2.638	L080160040
	mm	5	5	7	22	67	L08016M040
50 mm	inches	0.197	0.197	0.354	1.102	3.228	L080160050
	mm	5	5	9	28	82	L08016M050
63 mm	inches	0.197	0.197	0.354	1.378	3.74	L080160063
	mm	5	5	9	35	95	L08016M063

Inverted Mount

Provides mounting surface 180° from carriage

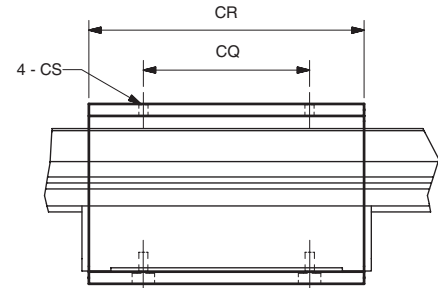
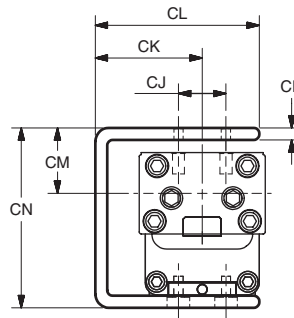
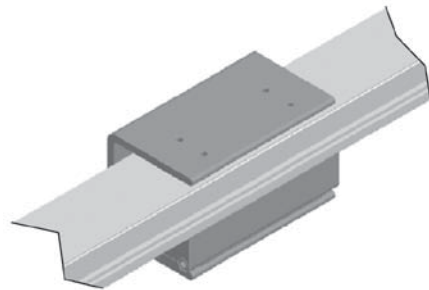

Inverted Mounts*

Bore		CJ	CK	CL	CM	CN	CP	CQ	CR	CS	Part Number**
16 mm	inches	0.591	1.398	1.969	1.142	2.362	0.236	1.89	3.465	5-40	L080170016
	mm	15	35.5	50	29	60	6	48	88		L08017M016
20 mm	inches	0.709	1.28	1.969	1.024	2.362	0.236	2.362	3.937	8-32	L080170020
	mm	18	32.5	50	26	60	6	60	100		L08017M020
25 mm	inches	0.787	1.772	2.717	1.181	2.795	0.197	2.756	4.567	10-24	L080170025
	mm	20	45	69	30.0	71	5	70	116		L08017M025
32 mm	inches	0.787	2.126	3.209	1.358	3.15	0.276	3.15	5.039	1/4-20	L080170032
	mm	20	54	81.5	34.5	80	7	80	128		L08017M032
40 mm	inches	1.181	2.48	3.76	1.516	3.602	0.315	3.543	5.433	1/4-20	L080170040
	mm	30	63	95.5	38.5	91.5	8	90	138		L08017M040
50 mm	inches	1.181	2.913	4.449	1.909	4.429	0.394	3.937	5.591	5/16-18	L080170050
	mm	30	74	113	48.5	112.5	10	100	142		L08017M050
63 mm	inches	1.575	3.465	5.433	2.283	5.157	0.512	4.331	6.22	5/16-18	L080170063
	mm	40	88	138	58	131	13	110	158		L08017M063

*Inverted mounts not available with adjustable stroke, shock absorber or tube center support bracket.

**Use this part number when ordering as a separate part. When ordering with cylinder, use "C" option as part of cylinder part number.

End Port Piping

Refer to Figure 10 to determine when end port piping can be used with various types of mountings relative to fitting clearance.

On all bore sizes with foot mounting, the end port pipe fittings will obstruct the mounting holes. To avoid this problem, mount the cylinder first and tighten the mounting bolts and then attach the pipe fittings to the cylinder ports.

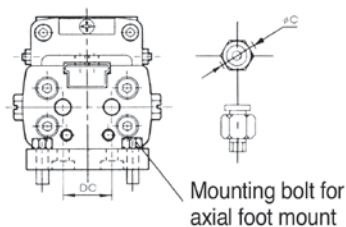

Figure 10

Bore Size (mm)	øC [O.D. of fittings - mm (in.)]		
	No Mount	End Mount	Bottom Mount
16	12 (0.472)	End Port Piping Not Available	12 (0.472)
20	16 (0.630)		16 (0.630)
25	26 (1.024)		26 (1.024)
32	27 (1.065)		27 (1.063)
40	35 (1.378)	26 (1.024)	
50	35 (1.378)	30 (1.181)	
63	39 (1.535)	34 (1.339)	

Selection Criteria

The Shock Absorber Advantage

- Increase equipment throughput
- Smoother deceleration of loads
- Adjustable end of stroke positioning
- Prevents impact damage
- Minimize shock loads on equipment
- Improves product performance

Four Steps to Great Performance

Step 1. Gather the Application Parameters

- Total load weight (pounds)
- Final velocity at impact (inches/second)*
- Cycle rate (cycles per hour)

Step 2. Verify Shock Absorber Performance

- See charts on the following pages
- Determine that shock absorber will do the job

Step 3. Verify the Cycle Rate

- See shock specifications below and verify application is within cycle rate

Step 4. Choose the Appropriate Option in Model Code

*If final velocity cannot be easily calculated, double the average velocity.

Shock Absorber Specifications

Figure 11 Specifications

Cylinder	16mm	20mm	25mm	32mm	40mm	50, 63mm
Shock Absorber No.	0887790016	0887790020	0887790025	0887790032	0887790040	0887790050
Max. Energy Absorption - in-lbs (kgf-m)	26.0 (0.3)	60.8 (0.7)	104.2 (1.2)	226 (2.6)	608 (7.0)	1042 (12)
Stroke - inches	0.236	0.315	0.394	0.590	0.787	0.984
Energy Absorption/hour - in.-lbs/hour	54,700	109,380	187,510	338,560	729,200	750,000
Max. Impact Velocity - in./sec.	59	59	78.7	78.7	98.4	118.1
Max. Cycle Rate per Hour	2100	1800	1800	1500	1200	720
Ambient Temperature - °F (°C)	41-140 (5-60)					
Spring Return Force - lb. Extended Compressed	0.65 1.01	0.45 0.97	0.65 1.33	1.33 2.65	2.20 4.86	3.60 7.49
Return Time - Sec.	0.3	0.3	0.3	0.3	0.4	0.4

Performance Data (16 - 32mm Bores)

----- Air Cushion w/back pressure (flow controls or other meter out device)
 Shock Absorber

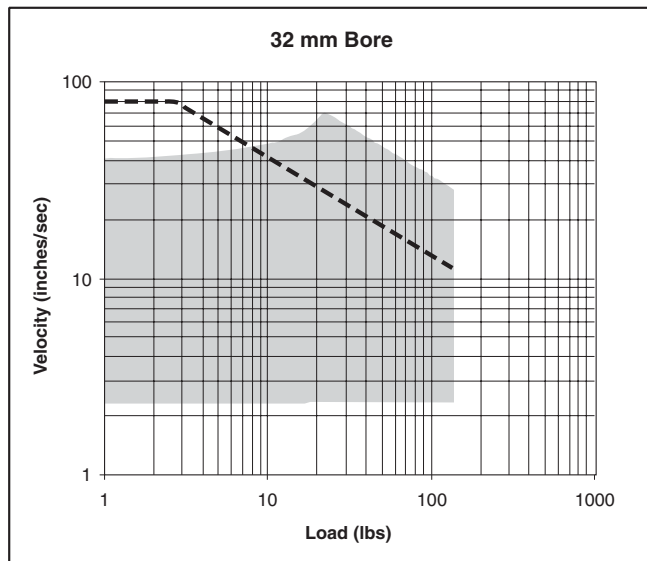
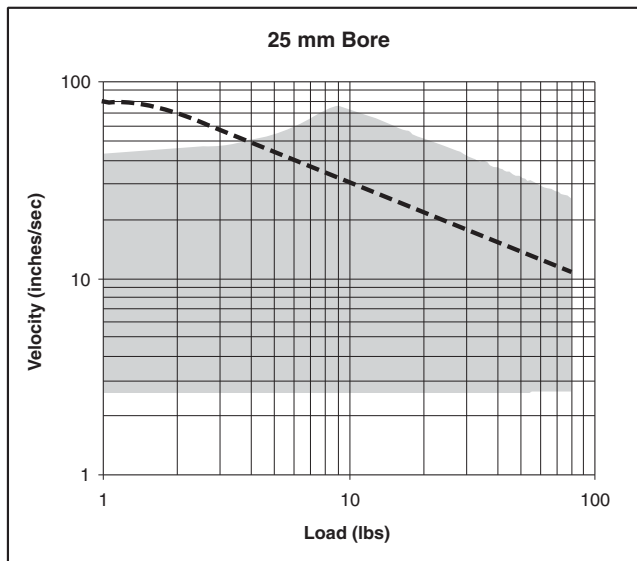
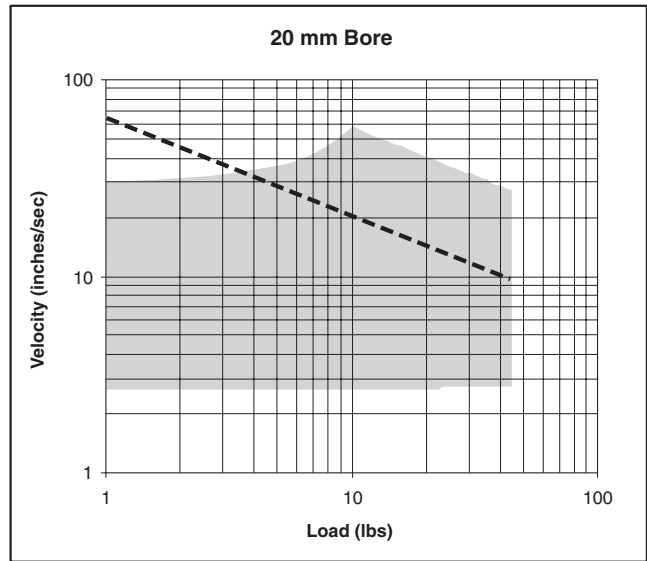
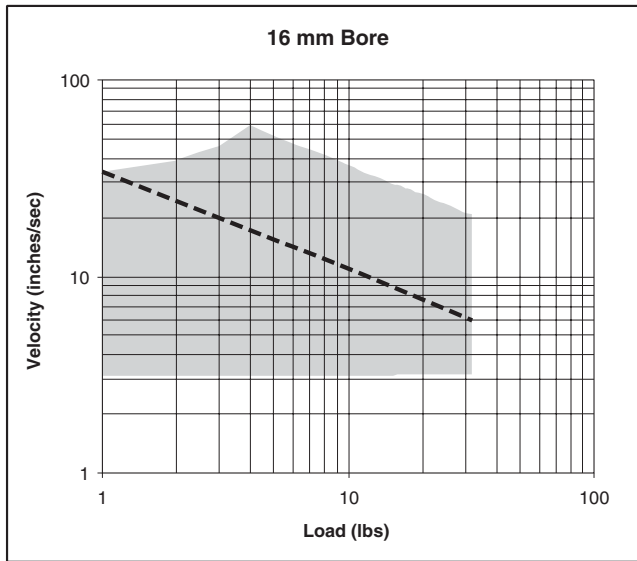

- Notes:**
1. If the cylinder is vertical in orientation, double the total load for bottom shock absorber.
 2. Use the total load that is being moved by shock absorber. If a weight transfer application, this would include La.
 3. If final velocity cannot be easily determined, use two times the stroke divided by the stroke time.

Performance Data (40 - 63mm Bores)

----- Air Cushion w/back pressure (flow controls or other meter out device)
 Shock Absorber

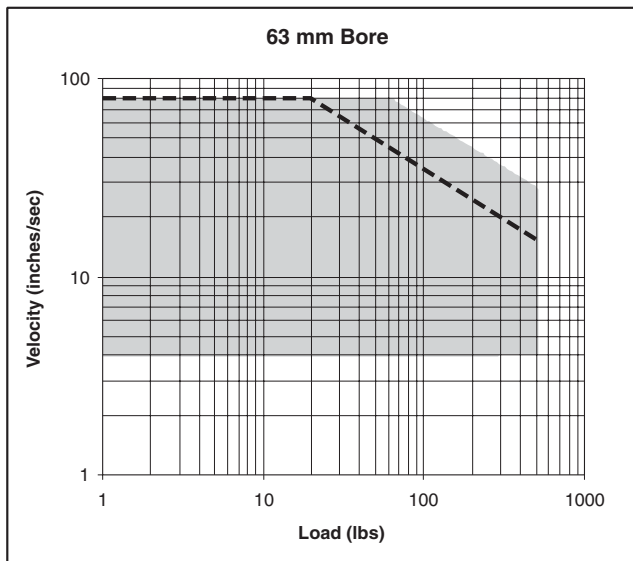
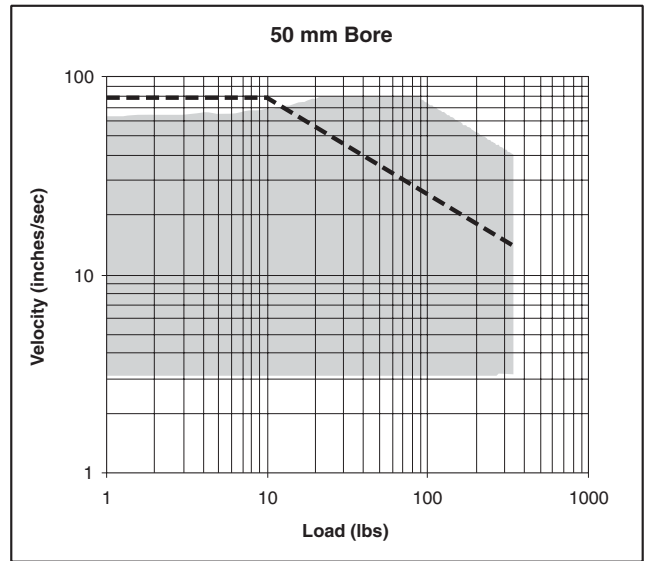
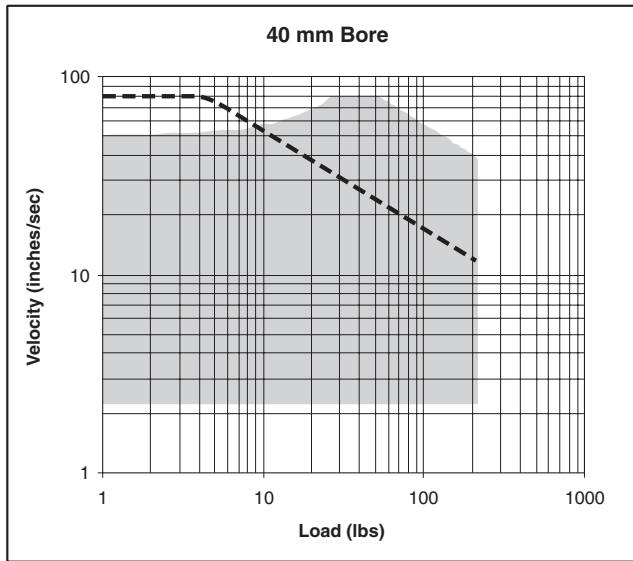

- Notes:**
1. If the cylinder is vertical in orientation, double the total load for bottom shock absorber.
 2. Use the total load that is being moved by shock absorber. If a weight transfer application, this would include La.
 3. If final velocity cannot be easily determined, use two times the stroke divided by the stroke time.

Stroke Adjustment and Shock Absorber Dimensions

16-25 mm Bore Sizes

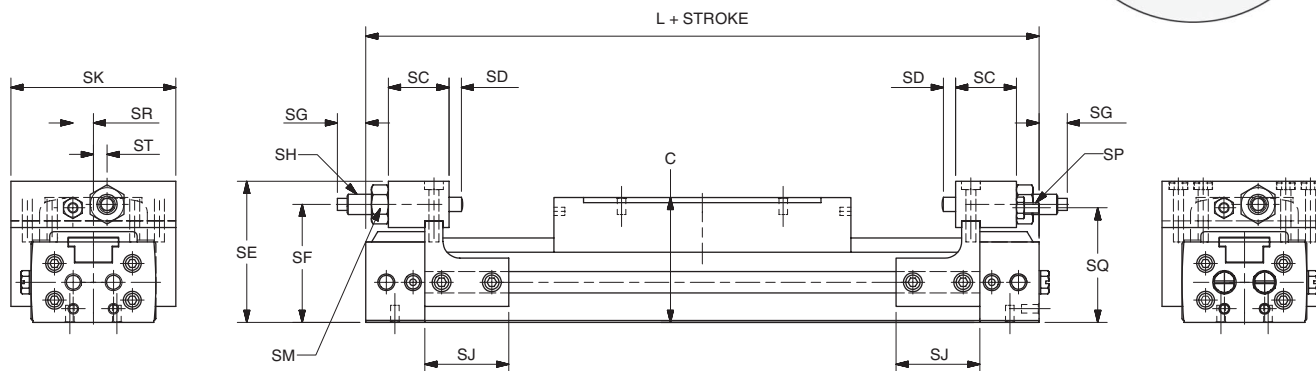
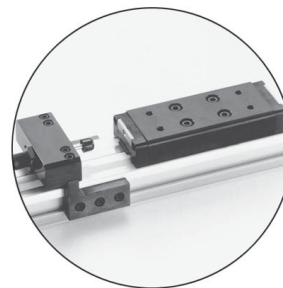

Bore (mm)		SC	SD	SE	SF	SG		SH in-lbs	SJ	SK	SP	SQ	SR	ST	C	L
						Max	Min									
16	in.	0.71	0.16	1.65	1.38	0.57	0.18	26	0.98	1.93	M3	1.34	0.24	0.16	1.46	5.87
	mm	18	4	42	35	14.5	4.5		25	49		34	6	4	37	149
20	in.	0.89	0.14	1.89	1.57	0.57	0.18	61	1.54	2.24	M4	1.50	0.32	0.20	1.65	6.65
	mm	22.5	3.5	48	40	14.5	4.5		39	57		38	8	5	42	169
25	in.	0.79	0.10	2.46	2.03	0.57	0.18	104	1.97	3.03	M6	1.97	0.47	0.39	2.09	7.48
	mm	20	2.5	62.5	51.5	14.5	4.5		50	77		50	12	10	53	190

SH = max. energy absorption

32-63 mm Bore Sizes

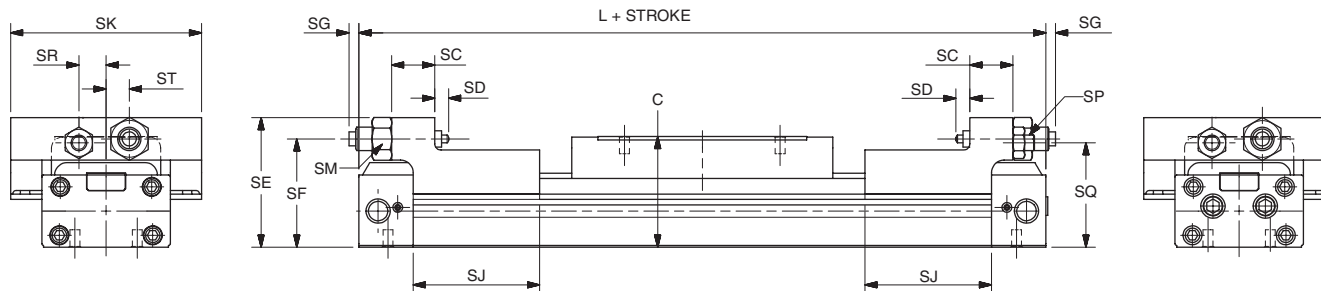

Bore (mm)		SC	SD	SE	SF	SG		SH in-lbs	SJ	SK	SP	SQ	SR	ST	C	L
						Max	Min									
32	in.	0.87	0.28	2.62	2.19	1.06	0.67	226	2.56	3.86	M8	2.11	0.55	0.47	2.24	8.90
	mm	22	7	66.5	55.5	27	17		65	98		53.5	14	12	57	226
40	in.	1.26	0.28	3.09	2.58	1.34	0.94	608	2.56	4.41	M10	2.50	0.67	0.47	2.64	9.61
	mm	32	7	78.5	65.5	34	24		65	112		63.5	17	12	67	244
50	in.	1.50	0.32	3.90	3.15	2.17	1.77	1042	2.76	5.35	M12	3.05	0.87	0.67	3.23	10.16
	mm	38	8	99	80	55	45		70	136		77.5	22	17	82	258
63	in.	1.50	0.32	4.41	3.68	1.73	1.34	1042	2.76	6.22	M16	3.50	0.98	0.79	3.74	11.65
	mm	38	8	112	93.5	44	34		70	158		89	25	20	95	296

SH = max. energy absorption

Positioning of Stroke Adjustment Unit

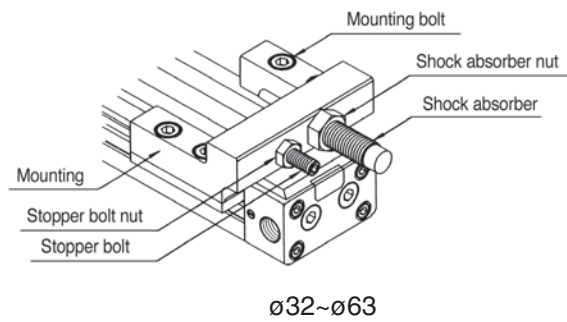
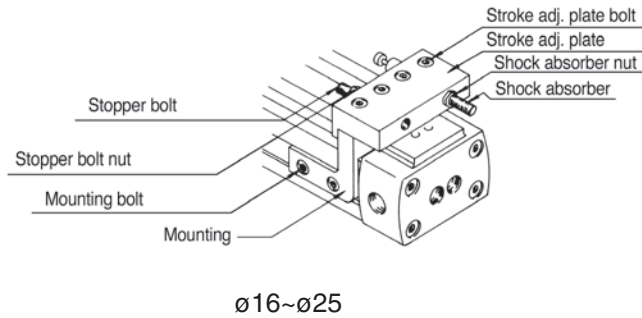

- (1) Moving the stroke adjustment unit.
The stroke adjustment unit can be moved by loosening the mounting bolts.
- (2) Locking of stroke adjustment unit.
After moving the stroke adjustment unit to the appropriate position, lock it there by tightening the mounting bolts to the torque values shown in Figure 12. Insufficient torque may cause the stroke adjustment unit to slip out of position.

- (4) Adjustment of shock absorber.
Adjust the absorption energy of the shock absorber by changing the operating stroke of the shock absorber. This is done by loosening the shock absorber nut and turning the unit. When adjustment is complete, tighten the shock absorber nut to the torque values shown in Figure 12a.
- (5) Notes on usage.
The shock absorber absorbs rated energy with rated stroke. The factory setting allows a small amount of shock absorber stroke before it bottoms out. Readjust the location of the shock absorber so that the complete stroke of the absorber is utilized.

Figure 12

Torque values for tightening stroke adjustment unit.

Bore Size	Tightening Torque	
	Mounting Bolt (lb-in)	Stroke Adj. Plate Bolt (lb-in)
16mm	9-11	4-6
20mm	22-24	
25mm	46-50	22-24
32mm	195-213	-
40mm	390-415	-
50, 63mm	682-735	-

- (3) Stroke adjustment using the stopper bolt.
Adjust the stroke by loosening the stopper bolt nut and turning the stopper bolt. After adjusting the stroke, tighten the stopper bolt nut to the torque values shown in Figure 12a. When adjusting the 16-25 mm cylinders, due to the small amount of clearance between the table and the stroke adjustment plate, adjust the stroke by moving the complete stroke adjustment unit.

Absorption energy as set at factory:
Small margin with stroke of shock absorber.

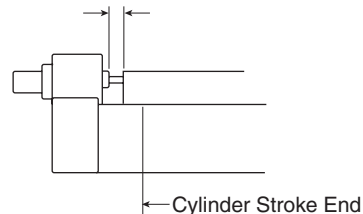

Adjust the position of the shock absorber until the plunger of the shock absorber is fully depressed.

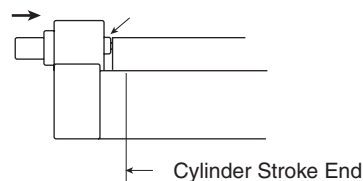

Figure 12a

Torque values for tightening stopper bolt nut and shock absorber nut.

Bore Size	Tightening Torque	
	Stopper Bolt Nut (lb-in)	Shock Absorber Nut (lb-in)
16mm	10-11	12-16
20mm	22-24	26-35
25mm	73-84	40-53
32mm	195-213	66-89
40mm	390-425	195-266
50mm	682-735	487-620
63mm	1772-1914	487-620

Sensor Selection Guide

Bore Size or Type	3m Flying Leads	10m Flying Leads	8mm Quick Connect*	8mm Quick Connect w/ 1 m Lead*	12mm Quick Connect*	Bracket
PNP Solid State Sensor						
All	P8S-GPFLX	P8S-GPFTX	P8S-GPSHX	P8S-GPSCX	P8S-GPMHX	P8S-TMA0Y
NPN Solid State Sensor						
All	P8S-GNFLX	P8S-GNFTX	P8S-GNSHX	P8S-GNSCX	P8S-GNMHX	P8S-TMA0Y
Reed Sensor						
All	P8S-GRFLX	P8S-GRFTX	P8S-GRSHX	P8S-GRSCX	P8S-GRMHX	P8S-TMA0Y

Global Drop-In Solid State Sensors  



Wiring	PNP Sensor	NPN Sensor	PNP Sensor ATEX Certified
3m Flying Leads	P8S-GPFLX	P8S-GNFLX	P8S-GPFLX/EX
10m Flying Leads	P8S-GPFTX	P8S-GNFTX	N/A
0.3m Lead with 8mm Connector	P8S-GPSHX	P8S-GNSHX	
0.3m Lead with 12mm Connector	P8S-GPMHX	P8S-GNMHX	
1m Lead with 8mm Connector	P8S-GPSCX	P8S-GNSCX	

Specifications

Switch Classification	Standard PNP or NPN	ATEX Certified PNP
Type	Electronic	
Output Function	Normally Open	
Sensor Output	PNP/NPN	PNP
Operating Voltage	10 - 30VDC	180 - 30VDC
Continuous Current	100 mA max.	70 mA max.
Response Sensitivity	28 Gauss min.	
Switching Frequency	1 KHz	
Power Consumption	10 mA max.	
Voltage Drop	2.5 VDC max.	
Ripple	10% of Operating Voltage	
Hysteresis	1.5 mm max.	
Repeatability	0.1 mm max.	
EMC	EN 60 947-5-2	
Short-circuit Protection	Yes	
Power-up Pulse Suppression	Yes	
Reverse Polarity Protection	Yes	
Enclosure Rating	IP 68	
Shock and Vibration Stress	30g, 11 ms, 10 to 55 Hz, 1 mm	
Operating Temperature Range	-25°C to +75°C (-13°F to 167°F)	-20°C to +45°C (-4°F to 113°F)
Housing Material	PA 12, Black	
Connector Cable	PVC	
Connector	PUR	—
Approval for ATEX	—	3D/3G

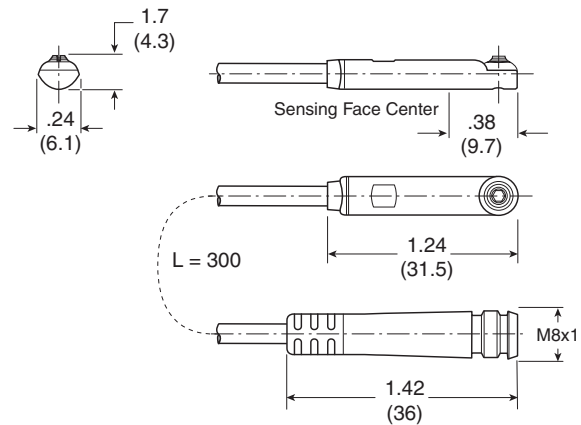

SOLID STATE SENSOR – WIRING CONNECTION

Flying Lead or 8 mm Connector (shown)

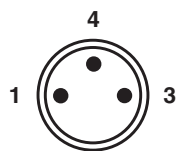

Pin	Wire	Function
1	Brown	Operating Voltage (+VDC)
4	Black	Output signal (N.O.)
3	Blue	-VDC

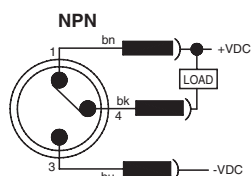
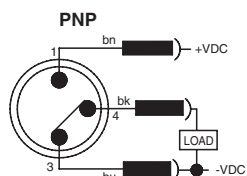

12 mm Connector

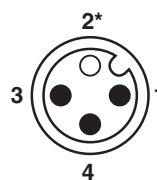

Pin	Wire	Function
1	Brown	Operating Voltage (+VDC)
4	Black	Output Signal (N.O.)
2*	White	Not Used
3	Blue	-VDC

* Pin 2 not present.

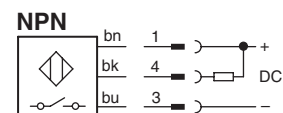
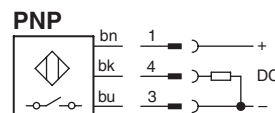

Global Drop-In Reed Sensors



Wiring	Reed Sensor
3m Flying Leads	P8S-GRFLX
10m Flying Leads	P8S-GRFTX
0.3m Lead with 8mm Connector	P8S-GRSHX
0.3m Lead with 12mm Connector	P8S-GRMHX
1m Lead with 8mm Connector	P8S-GRSCX

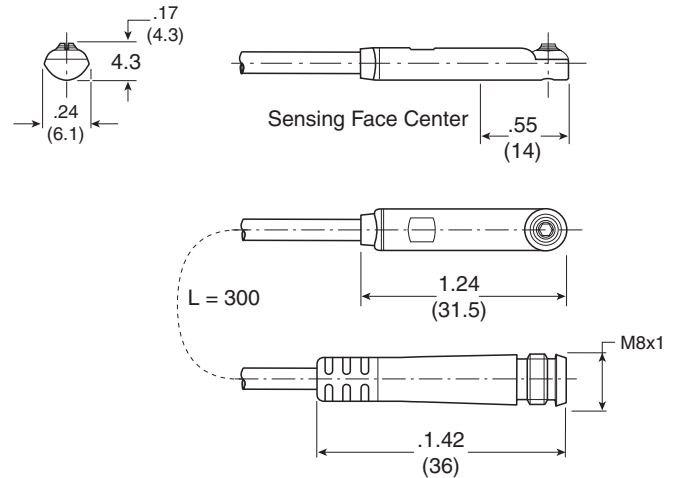

Specifications

Type	2-Wire Reed
Output Function	Normally Open
Operating Voltage	10 - 120 VAC*
	10 - 30 VDC
Switching Power	6 W/VA
Continuous Current	100 mA max.
Response Sensitivity	30 Gauss min.
Switching Frequency	400 Hz
Voltage Drop	2.5 V max.
Ripple	10% of Operating Voltage
Hysteresis	1.5 mm max.
Repeatability	0.2 mm max.
EMC	EN 60 947-5-2
Reverse Polarity Protection	Yes
Enclosure Rating	IP 68
Shock and Vibration Stress	30g, 11 ms, 10 to 55 Hz, 1 mm
Operating Temperature Range	-25°C to +75°C (-13°F to 167°F)
Housing Material	PA 12, Black
Connector Cable	PVC
Connector	PUR cable with 8 or 12 mm connector

*8mm connector rated for 50 VAC max.

REED SENSOR - WIRING CONNECTION			
Flying Lead or 8 mm Connector			
	Pin	Wire	Function
	1	Brown	Operating Voltage (+V)
	4	Black	Not Used
3	Blue	Output Signal (-V or Ground)	
12 mm Connector			
<p>* Pin 2 not present.</p>	Pin	Wire	Function
	1	Brown	Operating Voltage (+V)
	2*	White	Not Used
	3	Blue	Output Signal (-V or Ground)
4	Black	Not Used	

Circuit for Switching Contact Protection (For Inductive Loads, e.g. Solenoids, Relays)

(Required for proper operation 24V DC)

Put Diode parallel to load (CR) following polarity as shown below.

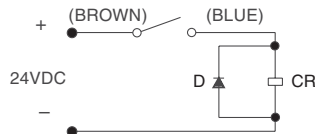

D: Diode: select a Diode with the breakdown voltage and current rating according to the load.

Typical Example – 100 Volt, 1 Amp Diode
 CR: Relay coil (under 0.5W coil rating)

(Recommended for longer life 120 VAC)

Put a resistor and capacitor in parallel with the load (CR). Select the resistor and capacitor according to the load.

Typical Example:

CR: Relay coil (under 2W coil rating)
 R: Resistor 1 KΩ - 5 KΩ, 1/4 W
 C: Capacitor 0.1 μF, 600 V

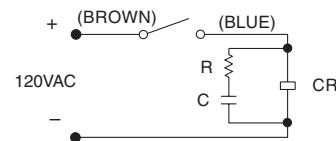

Caution

- Use an ammeter to test reed sensor current. Testing devices such as incandescent light bulbs may subject the reed sensor to high in-rush loads.
- **NOTE:** When checking an unpowered reed sensor for continuity with a digital ohmmeter the resistance reading will change from infinity to a very large resistance (2 M ohm) when the sensor is activated. This is due to the presence of a diode in the reed sensor.
- Anti-magnetic shielding is recommended for reed sensors exposed to high external RF or magnetic fields.
- The magnetic field strength of the piston magnet is designed to operate with our sensors. Other manufacturers' sensors may not operate correctly in conjunction with these magnets.

- Use relay coils for reed sensor contact protection.
- The operation of some 120 VAC PLC's (especially some older Allen-Bradley PLC's) can overload the reed sensor. The sensor may fail to release after the piston magnet has passed. This problem may be corrected by the placement of a 700 to 1K OHM resistor between the sensor and the PLC input terminal. Consult the manufacturer of the PLC for appropriate circuit.
- Sensors with long wire leads (greater than 15 feet) can cause capacitance build-up and sticking will result. Attach a resistor in series with the reed sensor (the resistor should be installed as close as possible to the sensor). The resistor should be selected such that R (ohms) > E/0.3.

Safety Guide

Safety Guide for Selecting and Using Hydraulic, Pneumatic Cylinders and Their Accessories

WARNING: ⚠ FAILURE OF THE CYLINDER, ITS PARTS, ITS MOUNTING, ITS CONNECTIONS TO OTHER OBJECTS, OR ITS CONTROLS CAN RESULT IN:

- Unanticipated or uncontrolled movement of the cylinder or objects connected to it.
- Falling of the cylinder or objects held up by it.
- Fluid escaping from the cylinder, potentially at high velocity.

THESE EVENTS COULD CAUSE DEATH OR PERSONAL INJURY BY, FOR EXAMPLE, PERSONS FALLING FROM HIGH LOCATIONS, BEING CRUSHED OR STRUCK BY HEAVY OR FAST MOVING OBJECTS, BEING PUSHED INTO DANGEROUS EQUIPMENT OR SITUATIONS, OR SLIPPING ON ESCAPED FLUID.

Before selecting or using Parker (The Company) cylinders or related accessories, it is important that you read, understand and follow the following safety information. Training is advised before selecting and using The Company's products.

1.0 General Instructions

1.1 Scope – This safety guide provides instructions for selecting and using (including assembling, installing, and maintaining) cylinder products. This safety guide is a supplement to and is to be used with the specific Company publications for the specific cylinder products that are being considered for use.

1.2 Fail Safe – Cylinder products can and do fail without warning for many reasons. All systems and equipment should be designed in a fail-safe mode so that if the failure of a cylinder product occurs people and property won't be endangered.

1.3 Distribution – Provide a free copy of this safety guide to each person responsible for selecting or using cylinder products. Do not select or use The Company's cylinders without thoroughly reading and understanding this safety guide as well as the specific Company publications for the products considered or selected.

1.4 User Responsibility – Due to very wide variety of cylinder applications and cylinder operating conditions, The Company does not warrant that any particular cylinder is suitable for any specific application. This safety guide does not analyze all technical parameters that must be considered in selecting a product. The hydraulic and pneumatic cylinders outlined in this catalog are designed to The Company's design guidelines and do not necessarily meet the design guideline of other agencies such as American Bureau of Shipping, ASME Pressure Vessel Code etc. The user, through its own analysis and testing, is solely responsible for:

- Making the final selection of the cylinders and related accessories.
- Determining if the cylinders are required to meet specific design requirements as required by the Agency(s) or industry standards covering the design of the user's equipment.
- Assuring that the user's requirements are met, OSHA requirements are met, and safety guidelines from the applicable agencies such as but not limited to ANSI are followed and that the use presents no health or safety hazards.
- Providing all appropriate health and safety warnings on the equipment on which the cylinders are used.

1.5 Additional Questions – Call the appropriate Company technical service department if you have any questions or require any additional information. See the Company publication for the product being considered or used, or call 1-800-CPARKER, or go to www.parker.com, for telephone numbers of the appropriate technical service department.

2.0 Cylinder and Accessories Selection

2.1 Seals – Part of the process of selecting a cylinder is the selection of seal compounds. Before making this selection, consult the "seal information page(s)" of the publication for the series of cylinders of interest.

The application of cylinders may allow fluids such as cutting fluids, wash down fluids etc. to come in contact with the external area of the cylinder. These fluids may attack the piston rod wiper and/or the primary seal and must be taken into account when selecting and specifying seal compounds.

Dynamic seals will wear. The rate of wear will depend on many operating factors. Wear can be rapid if a cylinder is mis-aligned or if the cylinder has been improperly serviced. The user must take seal wear into consideration in the application of cylinders.

2.2 Piston Rods – Possible consequences of piston rod failure or separation of the piston rod from the piston include, but are not limited to are:

- Piston rod and/or attached load thrown off at high speed.
- High velocity fluid discharge.
- Piston rod extending when pressure is applied in the piston retract mode.

Piston rods or machine members attached to the piston rod may move suddenly and without warning as a consequence of other conditions occurring to the machine such as, but not limited to:

- Unexpected detachment of the machine member from the piston rod.
- Failure of the pressurized fluid delivery system (hoses, fittings, valves, pumps, compressors) which maintain cylinder position.
- Catastrophic cylinder seal failure leading to sudden loss of pressurized fluid.
- Failure of the machine control system.

Follow the recommendations of the "Piston Rod Selection Chart and Data" in the publication for the series of cylinders of interest. The suggested piston rod diameter in these charts must be followed in order to avoid piston rod buckling.

Piston rods are not normally designed to absorb bending moments or loads which are perpendicular to the axis of piston rod motion. These additional loads can cause the piston rod to fail. If these types of additional loads are expected to be imposed on the piston rod, their magnitude should be made known to our engineering department.

The cylinder user should always make sure that the piston rod is securely attached to the machine member.

On occasion cylinders are ordered with double rods (a piston rod extended from both ends of the cylinder). In some cases a stop is threaded on to one of the piston rods and used as an external stroke adjuster. On occasions spacers are attached to the machine member connected to the piston rod and also used as a stroke adjuster. In both cases the stops will create a pinch point and the user should consider appropriate use of guards. If these external stops are not perpendicular to the mating contact surface, or if debris is trapped between the contact surfaces, a bending moment will be placed on the piston rod, which can lead to piston rod failure. An external stop will also negate the effect of cushioning and will subject the piston rod to impact loading. Those two (2) conditions can cause piston rod failure. Internal stroke adjusters are available with and without cushions. The use of external stroke adjusters should be reviewed with our engineering department.

The piston rod to piston and the stud to piston rod threaded connections are secured with an anaerobic adhesive. The strength of the adhesive decreases with increasing temperature. Cylinders which can be exposed to temperatures above +250°F (+121°C) are to be ordered with a non studded piston rod and a pinned piston rod to rod joint.

2.3 Cushions – Cushions should be considered for cylinder applications when the piston velocity is expected to be over 4 inches/second.

Cylinder cushions are normally designed to absorb the energy of a linear applied load. A rotating mass has considerably more energy than the same mass moving in a linear mode. Cushioning for a rotating mass application should be reviewed by our engineering department.

2.4 Cylinder Mountings – Some cylinder mounting configurations may have certain limitations such as but not limited to minimum stroke for side or foot mounting cylinders or pressure de-ratings for certain mounts. Carefully review the catalog for these types of restrictions.

Always mount cylinders using the largest possible high tensile alloy steel socket head cap screws that can fit in the cylinder mounting holes and torque them to the manufacturer's recommendations for their size.

2.5 Port Fittings – Hydraulic cylinders applied with meter out or deceleration circuits are subject to intensified pressure at piston rod end.

The rod end pressure is approximately equal to:

$$\frac{\text{operating pressure} \times \text{effective cap end area}}{\text{effective rod end piston area}}$$

Contact your connector supplier for the pressure rating of individual connectors.

3.0 Cylinder and Accessories Installation and Mounting

3.1 Installation

3.1.1 – Cleanliness is an important consideration, and cylinders are shipped with the ports plugged to protect them from contaminants entering the ports. These plugs should not be removed until the piping is to be installed. Before making the connection to the cylinder ports, piping should be thoroughly cleaned to remove all chips or burrs which might have resulted from threading or flaring operations.

3.1.2 – Cylinders operating in an environment where air drying materials are present such as fast-drying chemicals, paint, or weld splatter, or other hazardous conditions such as excessive heat, should have shields installed to prevent damage to the piston rod and piston rod seals.

3.1.3 – Proper alignment of the cylinder piston rod and its mating component on the machine should be checked in both the extended and retracted positions. Improper alignment will result in excessive rod gland and/or cylinder bore wear. On fixed mounting cylinders attaching the piston rod while the rod is retracted will help in achieving proper alignment.

3.1.4 – Sometimes it may be necessary to rotate the piston rod in order to thread the piston rod into the machine member. This operation must always be done with zero pressure being applied to either side of the piston. Failure to follow this procedure may result in loosening the piston to rod-threaded connection. In some rare cases the turning of the piston rod may rotate a threaded piston rod gland and loosen it from the cylinder head. Confirm that this condition is not occurring. If it does, re-tighten the piston rod gland firmly against the cylinder head.

For double rod cylinders it is also important that when attaching or detaching the piston rod from the machine member that the torque be applied to the piston rod end of the cylinder that is directly attaching to the machine member with the opposite end unrestrained. If the design of the machine is such that only the rod end of the cylinder opposite to where the rod attaches to the machine member can be rotated, consult the factory for further instructions.

3.2 Mounting Recommendations

3.2.1 – Always mount cylinders using the largest possible high tensile alloy steel socket head screws that can fit in the cylinder mounting holes and torque them to the manufacturer's recommendations for their size.

3.2.2 – Side-Mounted Cylinders – In addition to the mounting bolts, cylinders of this type should be equipped with thrust keys or dowel pins located so as to resist the major load.

3.2.3 – Tie Rod Mounting – Cylinders with tie rod mountings are recommended for applications where mounting space is limited. The standard tie rod extension is shown as BB in dimension tables. Longer or shorter extensions can be supplied. Nuts used for this mounting style should be torqued to the same value as the tie rods for that bore size.

3.2.4 – Flange Mount Cylinders – The controlled diameter of the rod gland extension on head end flange mount cylinders can be used as a pilot to locate the cylinders in relation to the machine. After alignment has been obtained, the flanges may be drilled for pins or dowels to prevent shifting.

3.2.5 – Trunnion Mountings – Cylinders require lubricated bearing blocks with minimum bearing clearances. Bearing blocks should be carefully aligned and rigidly mounted so the trunnions will not be subjected to bending moments. The rod end should also be pivoted with the pivot pin in line and parallel to axis of the trunnion pins.

3.2.6 – Clevis Mountings – Cylinders should be pivoted at both ends with centerline of pins parallel to each other. After cylinder is mounted, be sure to check to assure that the cylinder is free to swing through its working arc without interference from other machine parts.

4.0 Cylinder and Accessories Maintenance, Troubleshooting and Replacement

4.1 Storage – At times cylinders are delivered before a customer is ready to install them and must be stored for a period of time. When storage is required the following procedures are recommended.

4.1.1 – Store the cylinders in an indoor area which has a dry, clean and noncorrosive atmosphere. Take care to protect the cylinder from both internal corrosion and external damage.

4.1.2 – Whenever possible cylinders should be stored in a vertical position (piston rod up). This will minimize corrosion due to possible condensation which could occur inside the cylinder. This will also minimize seal damage.

4.1.3 – Port protector plugs should be left in the cylinder until the time of installation.

4.1.4 – If a cylinder is stored full of hydraulic fluid, expansion of the fluid due to temperature changes must be considered. Installing a check valve with free flow out of the cylinder is one method.

4.1.5 – When cylinders are mounted on equipment that is stored outside for extended periods, exposed unpainted surfaces, e.g. piston rod, must be coated with a rust-inhibiting compound to prevent corrosion.

4.2 Cylinder Trouble Shooting

4.2.1 – External Leakage

4.2.1.1 – Rod seal leakage can generally be traced to worn or damaged seals. Examine the piston rod for dents, gouges or score marks, and replace piston rod if surface is rough.

Rod seal leakage could also be traced to gland wear. If clearance is excessive, replace rod bushing and seal. Rod seal leakage can also be traced to seal deterioration. If seals are soft or gummy or brittle, check compatibility of seal material with lubricant used if air cylinder, or operating fluid if hydraulic cylinder. Replace with seal material, which is compatible with these fluids. If the seals are hard or have lost elasticity, it is usually due to exposure to temperatures in excess of 165°F. (+74°C). Shield the cylinder from the heat source to limit temperature to 350°F. (+177°C.) and replace with fluorocarbon seals.

4.2.1.2 – Cylinder body seal leak can generally be traced to loose tie rods. Torque the tie rods to manufacturer's recommendation for that bore size.

Excessive pressure can also result in cylinder body seal leak. Determine maximum pressure to rated limits. Replace seals and retorqued tie rods as in paragraph above. Excessive pressure can also result in cylinder body seal leak. Determine if the pressure rating of the cylinder has been exceeded. If so, bring the operating pressure down to the rating of the cylinder and have the tie rods replaced.

Pinched or extruded cylinder body seal will also result in a leak. Replace cylinder body seal and retorqued as in paragraph above.

Cylinder body seal leakage due to loss of radial squeeze which shows up in the form of flat spots or due to wear on the O.D. or I.D. – Either of these are symptoms of normal wear due to high cycle rate or length of service. Replace seals as per paragraph above.

4.2.2 – Internal Leakage

4.2.2.1 – Piston seal leak (by-pass) 1 to 3 cubic inches per minute leakage is considered normal for piston ring construction. Virtually no static leak with lipseal type seals on piston should be expected. Piston seal wear is a usual cause of piston seal leakage. Replace seals as required.

4.2.2.2 – With lipseal type piston seals excessive back pressure due to over-adjustment of speed control valves could be a direct cause of rapid seal wear. Contamination in a hydraulic system can result in a scored cylinder bore, resulting in rapid seal wear. In either case, replace piston seals as required.

4.2.2.3 – What appears to be piston seal leak, evidenced by the fact that the cylinder drifts, is not always traceable to the piston. To make sure, it is suggested that one side of the cylinder piston be pressurized and the fluid line at the opposite port be disconnected. Observe leakage. If none is evident, seek the cause of cylinder drift in other component parts in the circuit.

4.2.3 – Cylinder Fails to Move the Load

4.2.3.1 – Pneumatic or hydraulic pressure is too low. Check the pressure at the cylinder to make sure it is to circuit requirements.

4.2.3.2 – Piston Seal Leak – Operate the valve to cycle the cylinder and observe fluid flow at valve exhaust ports at end of cylinder stroke. Replace piston seals if flow is excessive.

4.2.3.3 – Cylinder is undersized for the load – Replace cylinder with one of a larger bore size.

4.3 Erratic or Chatter Operation

4.3.1 – Excessive friction at rod gland or piston bearing due to load misalignment – Correct cylinder-to-load alignment.

4.3.2 – Cylinder sized too close to load requirements – Reduce load or install larger cylinder.

4.3.3 – Erratic operation could be traced to the difference between static and kinetic friction. Install speed control valves to provide a back pressure to control the stroke.

4.4 Cylinder Modifications, Repairs, or Failed Component – Cylinders as shipped from the factory are not to be disassembled and/or modified. If cylinders require modifications, these modifications must be done at company locations or by The Company's certified facilities. The Cylinder Division Engineering Department must be notified in the event of a mechanical fracture or permanent deformation of any cylinder component (excluding seals). This includes a broken piston rod, tie rod, mounting accessory or any other cylinder component. The notification should include all operation and application details. This information will be used to provide an engineered repair that will prevent recurrence of the failure.

It is allowed to disassemble cylinders for the purpose of replacing seals or seal assemblies. However, this work must be done by strictly following all the instructions provided with the seal kits.

PARKER-HANNIFIN CORPORATION
OFFER OF SALE

1. **Definitions.** As used herein, the following terms have the meanings indicated.

Buyer:	means any customer receiving a Quote for Products from Seller.
Goods:	means any tangible part, system or component to be supplied by the Seller.
Products:	means the Goods, Services and/or Software as described in a Quote provided by the Seller.
Quote:	means the offer or proposal made by Seller to Buyer for the supply of Products.
Seller:	means Parker-Hannifin Corporation, including all divisions and businesses thereof.
Services:	means any services to be supplied by the Seller.
Software:	means any software related to the Products, whether embedded or separately downloaded.
Terms:	means the terms and conditions of this Offer of Sale or any newer version of the same as published by Seller electronically at www.parker.com/saleterms .

2. **Terms.** All sales of Products by Seller are contingent upon, and will be governed by, these Terms and, these Terms are incorporated into any Quote provided by Seller to any Buyer. Buyer's order for any Products whether communicated to Seller verbally, in writing, by electronic data interface or other electronic commerce, shall constitute acceptance of these Terms. Seller objects to any contrary or additional terms or conditions of Buyer. Reference in Seller's order acknowledgement to Buyer's purchase order or purchase order number shall in no way constitute an acceptance of any of Buyer's terms of purchase. No modification to these Terms will be binding on Seller unless agreed to in writing and signed by an authorized representative of Seller.

3. **Price; Payment.** The Products set forth in Seller's Quote are offered for sale at the prices indicated in Seller's Quote. Unless otherwise specifically stated in Seller's Quote, prices are valid for thirty (30) days and do not include any sales, use, or other taxes or duties. Seller reserves the right to modify prices at any time to adjust for any raw material price fluctuations. Unless otherwise specified by Seller, all prices are F.C.A. Seller's facility (INCOTERMS 2010). All sales are contingent upon credit approval and payment for all purchases is due thirty (30) days from the date of invoice (or such date as may be specified in the Quote). Unpaid invoices beyond the specified payment date incur interest at the rate of 1.5% per month or the maximum allowable rate under applicable law.

4. **Shipment; Delivery; Title and Risk of Loss.** All delivery dates are approximate. Seller is not responsible for damages resulting from any delay. Regardless of the manner of shipment, delivery occurs and title and risk of loss or damage pass to Buyer, upon placement of the Products with the shipment carrier at Seller's facility. Unless otherwise agreed, Seller may exercise its judgment in choosing the carrier and means of delivery. No deferment of shipment at Buyer's request beyond the respective indicated shipping date will be made except on terms that will indemnify, defend and hold Seller harmless against all loss and additional expense. Buyer shall be responsible for any additional shipping charges incurred by Seller due to Buyer's acts or omissions.

5. **Warranty.** The warranty related to the Products is as follows: (i) Goods are warranted against defects in material or workmanship for a period of twelve (12) months from the date of delivery or 2,000 hours of use, whichever occurs first; (ii) Services shall be performed in accordance with generally accepted practices and using the degree of care and skill that is ordinarily exercised and customary in the field to which the Services pertain and are warranted for a period of six (6) months from the completion of the Services by Seller; and (iii) Software is only warranted to perform in accordance with applicable specifications provided by Seller to Buyer for ninety (90) days from the date of delivery or, when downloaded by a Buyer or end-user, from the date of the initial download. All prices are based upon the exclusive limited warranty stated above, and upon the following disclaimer:

DISCLAIMER OF WARRANTY: THIS WARRANTY IS THE SOLE AND ENTIRE WARRANTY PERTAINING TO PRODUCTS. SELLER DISCLAIMS ALL OTHER WARRANTIES, EXPRESS AND IMPLIED, INCLUDING DESIGN, NONINFRINGEMENT, MERCHANTABILITY, AND FITNESS FOR A PARTICULAR PURPOSE. SELLER DOES NOT WARRANT THAT THE SOFTWARE IS ERROR-FREE OR FAULT-TOLERANT, OR THAT BUYER'S USE THEREOF WILL BE SECURE OR UNINTERRUPTED. BUYER AGREES AND ACKNOWLEDGES THAT UNLESS OTHERWISE AUTHORIZED IN WRITING BY SELLER THE SOFTWARE SHALL NOT BE USED IN CONNECTION WITH HAZARDOUS OR HIGH RISK ACTIVITIES OR ENVIRONMENTS. EXCEPT AS EXPRESSLY STATED HEREIN, ALL PRODUCTS ARE PROVIDED "AS IS".

6. **Claims; Commencement of Actions.** Buyer shall promptly inspect all Products upon receipt. No claims for shortages will be allowed unless reported to the Seller within ten (10) days of delivery. Buyer shall notify Seller of any alleged breach of warranty within thirty (30) days after the date the non-conformance is or should have been discovered by Buyer. Any claim or action against Seller based upon breach of contract or any other theory, including tort, negligence, or otherwise must be commenced within twelve (12) months from the date of the alleged breach or other alleged event, without regard to the date of discovery.

7. **LIMITATION OF LIABILITY.** IN THE EVENT OF A BREACH OF WARRANTY, SELLER WILL, AT ITS OPTION, REPAIR OR REPLACE THE NON-CONFORMING PRODUCT, RE-PERFORM THE SERVICES, OR REFUND THE PURCHASE PRICE PAID WITHIN A REASONABLE PERIOD OF TIME. IN NO EVENT IS SELLER LIABLE FOR ANY SPECIAL, INDIRECT, INCIDENTAL OR CONSEQUENTIAL DAMAGES ARISING OUT OF, OR AS THE RESULT OF, THE SALE, DELIVERY, NON-DELIVERY, SERVICING, NON-COMPLETION OF SERVICES, USE, LOSS OF USE OF, OR INABILITY TO USE THE PRODUCTS OR ANY PART THEREOF, LOSS OF DATA, IDENTITY, PRIVACY, OR CONFIDENTIALITY, OR FOR ANY CHARGES OR EXPENSES OF ANY NATURE INCURRED WITHOUT SELLER'S WRITTEN CONSENT, WHETHER BASED IN CONTRACT, TORT OR OTHER LEGAL THEORY. IN NO EVENT SHALL SELLER'S LIABILITY UNDER ANY CLAIM MADE BY BUYER EXCEED THE PURCHASE PRICE PAID FOR THE PRODUCTS.

8. **Loss to Buyer's Property.** Any designs, tools, patterns, materials, drawings, confidential information or equipment furnished by Buyer or any other items which are or become Buyer's property, will be considered obsolete and may be destroyed by Seller after two (2) consecutive years have elapsed without Buyer ordering the Products manufactured using such property. Seller shall not be responsible for any loss or damage to such property while it is in Seller's possession or control.

9. **Special Tooling.** Special Tooling includes but is not limited to tooling, jigs, fixtures and associated manufacturing equipment acquired or necessary to manufacture Products. A tooling charge may be imposed for any Special Tooling. Such Special Tooling shall be and remain Seller's property notwithstanding payment of any charges by Buyer. In no event will Buyer acquire any interest in Special Tooling belonging to Seller that is utilized in the manufacture of the Products, even if such Special Tooling has been specially converted or adapted for such manufacture and notwithstanding any charges paid by Buyer. Unless otherwise agreed, Seller has the right to alter, discard or otherwise dispose of any Special Tooling or other property in its sole discretion at any time.

10. **Security Interest.** To secure payment of all sums due, Seller retains a security interest in all Products delivered to Buyer and, Buyer's acceptance of these Terms is deemed to be a Security Agreement under the Uniform Commercial Code. Buyer authorizes Seller as its attorney to execute and file on Buyer's behalf all documents Seller deems necessary to perfect its security interest.

11. **User Responsibility.** The Buyer through its own analysis and testing, is solely responsible for making the final selection of the Products and assuring that all performance, endurance, maintenance, safety and warning requirements of the application of the Products are met. The Buyer must analyze all aspects of the application and follow applicable industry standards, specifications, and other technical information provided with the Product. If Seller provides Product options based upon data or specifications provided by the Buyer, the Buyer is responsible for determining that such data and specifications are suitable and sufficient for all applications and reasonably foreseeable uses of the Products. In the event the Buyer is not the end-user, Buyer will ensure such end-user complies with this paragraph.

12. **Use of Products; Indemnity by Buyer.** Buyer shall comply with all instructions, guides and specifications provided by Seller with the Products. **Unauthorized Uses.** If Buyer uses or resells the Products for any uses prohibited in Seller's instructions, guides or specifications, or Buyer otherwise fails to comply with Seller's instructions, guides and specifications, Buyer acknowledges that any such use, resale, or non-compliance is at Buyer's sole risk. Buyer shall indemnify, defend, and hold Seller harmless from any losses, claims, liabilities, damages, lawsuits, judgments and costs (including attorney fees and defense costs), whether for personal injury, property damage, intellectual property infringement or any other claim, brought by or incurred by Buyer, Buyer's employees, or any other person, arising out of: (a) improper selection, application, design, specification or other misuse of Products provided by Seller; (b) any act or omission, negligent or otherwise, of Buyer; (c) Seller's use of patterns, tooling, equipment, plans, drawings, designs or specifications or other information or things furnished by Buyer; (d) damage to the Products from an external cause, repair or attempted repair by anyone other than Seller, failure to follow instructions, guides and specifications provided by Seller, use with goods not provided by Seller, or opening, modifying, deconstructing or tampering with the Products for any reason; or (e) Buyer's failure to comply with these Terms. Seller shall not indemnify Buyer under any circumstance except as otherwise provided in these Terms.

13. **Cancellations and Changes.** Buyer may not cancel or modify any order for any reason, except with Seller's written consent and upon terms that will indemnify, defend and hold Seller harmless against all direct, incidental and consequential loss or damage. Seller, at any time, may change Product features, specifications, designs and availability.

14. **Limitation on Assignment.** Buyer may not assign its rights or obligations without the prior written consent of Seller.

15. **Force Majeure.** Seller does not assume the risk and is not liable for delay or failure to perform any of Seller's obligations by reason of events or circumstances beyond its reasonable control ("Events of Force Majeure"). Events of Force Majeure shall include without limitation: accidents, strikes or labor disputes, acts of any government or government agency, acts of nature, delays or failures in delivery from carriers or suppliers, shortages of materials, or any other cause beyond Seller's reasonable control.

16. **Waiver and Severability.** Failure to enforce any provision of these Terms will not invalidate that provision; nor will any such failure prejudice Seller's right to enforce that provision in the future. Invalidation of any provision of these Terms by legislation or other rule of law shall not invalidate any other provision herein and, the remaining provisions will remain in full force and effect.

17. **Termination.** Seller may terminate any agreement governed by or arising from these Terms for any reason and at any time by giving Buyer thirty (30) days prior written notice. Seller may immediately terminate, in writing, if Buyer: (a) breaches any provision of these Terms (b) appoints a trustee, receiver or custodian for all or any part of Buyer's property (c) files a petition for relief in bankruptcy on its own behalf, or one filed by a third party (d) makes an assignment for the benefit of creditors; or (e) dissolves its business or liquidates all or a majority of its assets.

18. **Ownership of Software.** Seller retains ownership of all Software supplied to Buyer hereunder. In no event shall Buyer obtain any greater right in and to the Software than a right in the nature of a license limited to the use thereof and subject to compliance with any other terms provided with the Software.

19. **Indemnity for Infringement of Intellectual Property Rights.** Seller is not liable for infringement of any patents, trademarks, copyrights, trade dress, trade secrets or similar rights ("Intellectual Property Rights") except as provided in this Section. Seller will defend at its expense and will pay the cost of any settlement or damages awarded in an action brought against Buyer based on a third party claim that one or more of the Products sold hereunder infringes the Intellectual Property Rights of a third party in the country of delivery of the Products by the Seller to the Buyer. Seller's obligation to defend and indemnify Buyer is contingent on Buyer notifying Seller within ten (10) days after Buyer becomes aware of any such claim, and Seller having sole control over the defense of the claim including all negotiations for settlement or compromise. If one or more Products sold hereunder is subject to such a claim, Seller may, at its sole expense and option, procure for Buyer the right to continue using the Products, replace or modify the Products so as to render them non-infringing, or offer to accept return of the Products and refund the purchase price less a reasonable allowance for depreciation. Seller has no obligation or liability for any claim of infringement: (i) arising from information provided by Buyer; or (ii) directed to any Products provided hereunder for which the designs are specified in whole or part by Buyer; or (iii) resulting from the modification, combination or use in a system of any Products provided hereunder. The foregoing provisions of this Section constitute Seller's sole and exclusive liability and Buyer's sole and exclusive remedy for such claims of infringement of Intellectual Property Rights.

20. **Governing Law.** These Terms and the sale and delivery of all Products are deemed to have taken place in, and shall be governed and construed in accordance with, the laws of the State of Ohio, as applicable to contracts executed and wholly performed therein and without regard to conflicts of laws principles. Buyer irrevocably agrees and consents to the exclusive jurisdiction and venue of the courts of Cuyahoga County, Ohio with respect to any dispute, controversy or claim arising out of or relating to the sale and delivery of the Products.

21. **Entire Agreement.** These Terms, along with the terms set forth in the main body of any Quote, forms the entire agreement between the Buyer and Seller and constitutes the final, complete and exclusive expression of the terms of sale. In the event of a conflict between any term set forth in the main body of a Quote and these Terms, the terms set forth in the main body of the Quote shall prevail. All prior or contemporaneous written or oral agreements or negotiations with respect to the subject matter shall have no effect. These Terms may not be modified unless in writing and signed by an authorized representative of Seller.

22. **Compliance with Laws.** Buyer agrees to comply with all applicable laws, regulations, and industry and professional standards, including those of the United States of America, and the country or countries in which Buyer may operate, including without limitation the U.S. Foreign Corrupt Practices Act ("FCPA"), the U.S. Anti-Kickback Act ("Anti-Kickback Act"), U.S. and E.U. export control and sanctions laws ("Export Laws"), the U.S. Food Drug and Cosmetic Act ("FDCA"), and the rules and regulations promulgated by the U.S. Food and Drug Administration ("FDA"), each as currently amended. Buyer agrees to indemnify, defend, and hold harmless Seller from the consequences of any violation of such laws, regulations and standards by Buyer, its employees or agents. Buyer acknowledges that it is familiar with all applicable provisions of the FCPA, the Anti-Kickback Act, Export Laws, the FDCA and the FDA and certifies that Buyer will adhere to the requirements thereof and not take any action that would make Seller violate such requirements. Buyer represents and agrees that Buyer will not make any payment or give anything of value, directly or indirectly, to any governmental official, foreign political party or official thereof, candidate for foreign political office, or commercial entity or person, for any improper purpose, including the purpose of influencing such person to purchase Products or otherwise benefit the business of Seller. Buyer further represents and agrees that it will not receive, use, service, transfer or ship any Product from Seller in a manner or for a purpose that violates Export Laws or would cause Seller to be in violation of Export Laws.



Parker Hannifin Corporation
Pneumatic Division
135 Quadral Drive
Wadsworth, OH 44281 USA
Tel: 330 336 3511
Fax: 330 334 3335
Web site: www.parker.com/pneumatics