



aerospace
climate control
electromechanical
filtration
fluid & gas handling
hydraulics
pneumatics
process control
sealing & shielding



Compact Pneumatic Cylinders P1P Series

According to ISO 21287

Catalogue PDE2660TCUK September 2013

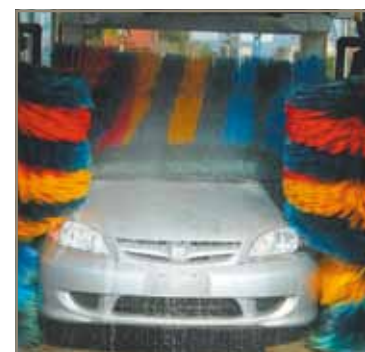

ENGINEERING YOUR SUCCESS.

ARA[®]
PNEUMATIK

53-012 Wrocław tel. 71 364 72 82
ul. Wyścigowa 38 fax 71 364 72 83

www.arapneumatik.pl



Features	3 - 4
Technical Information	
General technical data	5
Operating and environmental data	5
Material specification	5
Cylinder forces	6
Application Guide	7
Order code key	8
Standard stroke length	8
Order Codes	
Double acting with female piston rod thread	9
Double acting with guided piston rod	10
Single acting with female piston rod thread	11
Double acting through piston rod with female piston rod thread	12
Double acting low temperature with female piston rod thread	13
Double acting high temperature with female piston rod thread	14
Dimensions	
Double acting with female piston rod thread - Bore 20 - 63 mm.....	15
Double acting with guided piston rod - Bore 20 - 63 mm	15
Double acting with male piston rod thread - Bore 20 - 63 mm	15
Double acting with female piston rod thread - Bore 80 - 100 mm.....	16
Double acting with guided piston rod - Bore 80 - 100 mm	16
Double acting with male piston rod thread - Bore 80 - 100 mm	16
Mountings	
Flange	17
Foot bracket	17
Pivot bracket with rigid bearing	18
Clevis bracket MP2	18
Clevis bracket MP4	19
Clevis bracket GA	19
Pivot bracket with swivel bearing	20
Swivel eye bracket	20
Mounting kit	21
Swivel rod eye	22
Clevis	22
Flexo coupling	23
Nut	23
Accessories	
Sensors	25 - 27
Repair Kits	28
Air Quality	29

 **WARNING**

FAILURE OR IMPROPER SELECTION OR IMPROPER USE OF THE PRODUCTS AND/OR SYSTEMS DESCRIBED HEREIN OR RELATED ITEMS CAN CAUSE DEATH, PERSONAL INJURY AND PROPERTY DAMAGE.

This document and other information from Parker Hannifin Corporation, its subsidiaries and authorized distributors provide product and/or system options for further investigation by users having technical expertise. It is important that you analyze all aspects of your application including consequences of any failure, and review the information concerning the product or system in the current product catalog. Due to the variety of operating conditions and applications for these products or systems, the user, through its own analysis and testing, is solely responsible for making the final selection of the products and systems and assuring that all performance, safety and warning requirements of the application are met.

The products described herein, including without limitation, product features, specifications, designs, availability and pricing, are subject to change by Parker Hannifin Corporation and its subsidiaries at any time without notice.

Offer of Sale

The items described in this document are hereby offered for sale by Parker Hannifin Corporation, its subsidiaries or its authorized distributors. This offer and its acceptance are governed by the provisions stated on the separate page of this document entitled "Offer of Sale".



P1P Compact Cylinder according to ISO 21287

The P1P Series is a complete range of ISO 21287 compact cylinders developed to meet the highest requirements for quality and performance. The careful design in every detail provides first class function and service life properties.

Features

- ISO 21287 conformity and global availability throughout the worldwide Parker Hannifin organization.
- Bore sizes 20, 25, 32, 40, 50, 63, 80 and 100mm.
- One of the widest ranges of sizes and versions for a broad range of applications.
- Corrosion resistant design with end covers and barrel in anodised aluminium and stainless steel piston rod.
- Long service life thanks to proven high quality materials, surfaces and seal technology.
- Compact design and many installation alternatives for flexible use in narrow spaces.
- Efficient elastic cushioning absorbing residual energy facilitates high speeds and short cycle times.
- Smooth, low noise operation thanks to elastic material in end faces of the piston.
- Flush, drop in global P8S-G sensors on all side faces for flexible and compact assembly and mechanical protection of the sensors.
- P1P is suitable for processing, packaging and handling applications within the food industry thanks to the food approved grease used for the initial greasing.

High quality

Reliability and long service life are key qualities of any pneumatic cylinder. Therefore we have given P1P highest possible quality in every detail based on our 40 years of experience and extensive testing. The design is based on the following important principles.

- Proven seal design and materials throughout the cylinder. The expertise for seal technology within Parker Hannifin is the basis for leading and proven tribology solutions for all our pneumatic actuators.
- Body extrusion in anodised aluminium with extra fine and hard internal surface for optimum operational conditions.
- End covers and body extrusion with external anodisation for excellent corrosion resistance.
- Stainless steel piston rod for versatile use in corrosive environment.

Compact dimensions for versatile use

The very compact axial dimensions makes it possible to use the P1P cylinders in a broad range of applications. Note that the P1P cylinders are up to 50% shorter than ISO 15552 cylinders for the same stroke length. This is highly valuable in narrow spaces in machines or production lines. The P1P range is a truly versatile cylinder family.

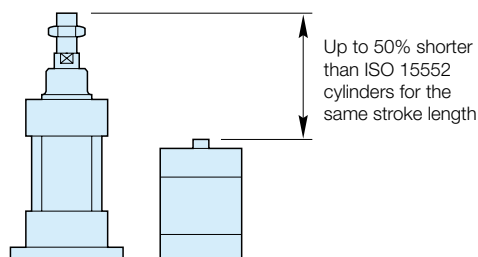

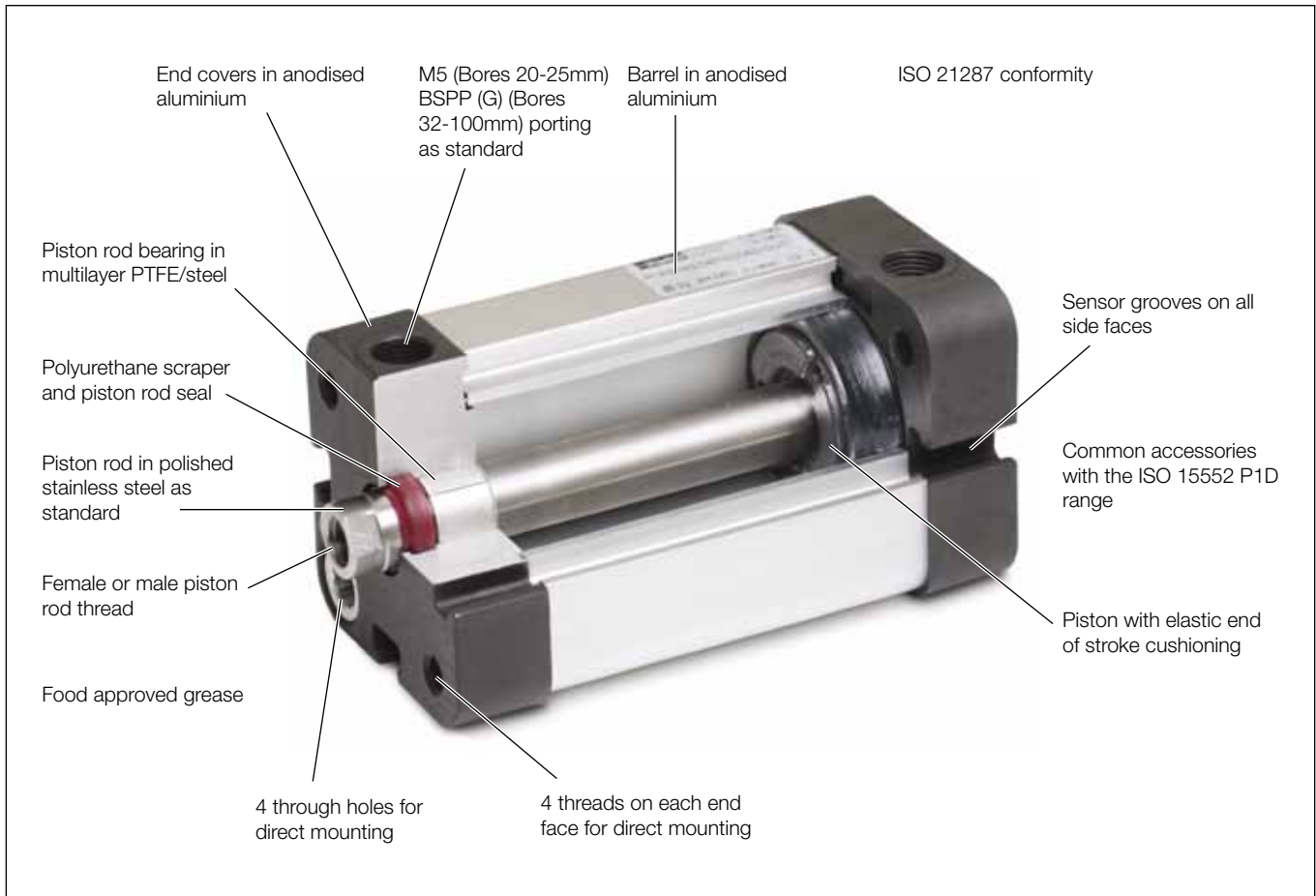

Flexible installation

The new P1P compact cylinder range offers many opportunities for mechanical installation.

- There are holes through the cylinder body. Use these to fix the cylinder with through bolts into threads in the surface behind the cylinder.
- In each end of the same through holes there are female threads. These can be used for flange mounting of the actuator from the rear or front face.
- The wide range of ISO 15552 cylinder mountings are available for use with P1P cylinders bore 20-100 mm. Examples are the foot and flange mountings, as well as MP2 and MP4 mountings for articulated applications.

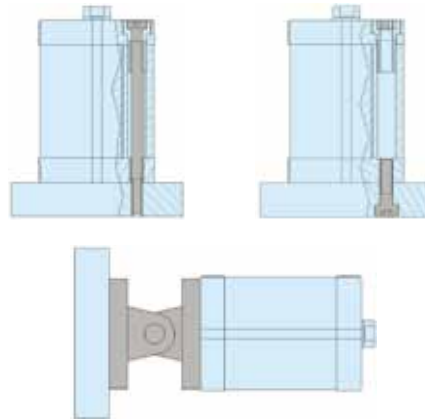

Global drop-in P8S-G sensor range

The global sensor range P8S-G fits P1P as well as most of our pneumatic cylinder families. This simplifies your ordering, stock and overall service of sensors.

The P8S-G sensors has a drop-in mounting into the sensor grooves facilitating the assembly and commissioning work. There are sensor grooves on all four side faces for maximum flexibility and adaptation to each application.

The wide range of P8S-G sensors includes both reed and solid state sensors, flying lead versions with 3 and 10 meter cable and pig tail versions with M8 and M12 connector.

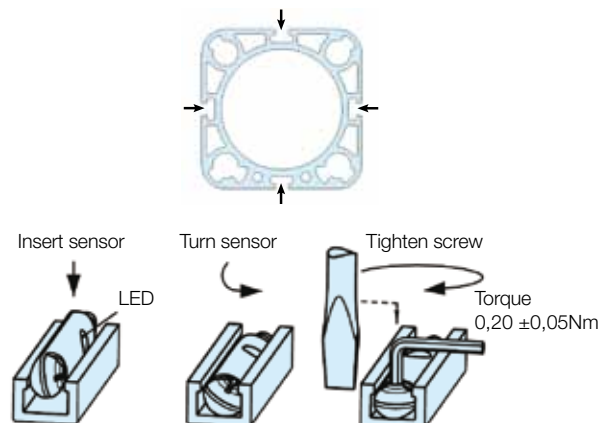

General technical data

Product type	Compact cylinder according to ISO 21287	
Bore size	20 - 100 mm	
Stroke length	1 - 500 mm	
Versions	P1PS...DS	Double acting
	P1PG...DS	Double acting with non rotating piston rod
	P1PS...SS	Single acting: Spring return (Bores 20 - 63mm)
	P1PS...TS	Single acting: Spring extended (Bores 20 - 63mm)
	P1PS...KS	Through piston rod
	P1PS...DF	High temperature
	P1PS...DL	Low temperature
Cushioning	Elastic cushioning	
Position sensing	Proximity sensor	
Installation	Direct	Through holes Female thread on front and rear end face
	Accessories	Cylinder and piston rod mountings
Mounting position	Any	

Operating and environmental data

Operating medium	For best possible service life and trouble-free operation it is recommended to use dry, filtered compressed air to ISO 8573-1:2010 quality class 3.4.3. This specifies a dew point of +3°C for indoor operation (a lower dew point should be selected for minus temperature operation and we recommend the use of an inline dryer) and is in line with the air quality from most standard compressors with a standard filter.	
Operating pressure	0.5 bar to 10 bar	
Ambient temperature	Standard version	-20°C to +80°C
	High temperature	-10°C to +120°C
	Low temperature	-40°C to +80°C
Pre-lubricated	Further lubrication is normally not necessary. If additional lubrication is introduced it must be continued.	
Corrosion resistance	High resistance to corrosion and chemicals. Materials and surface treatment have been selected for industrial applications where solvents and detergents are frequently used.	

Material specification

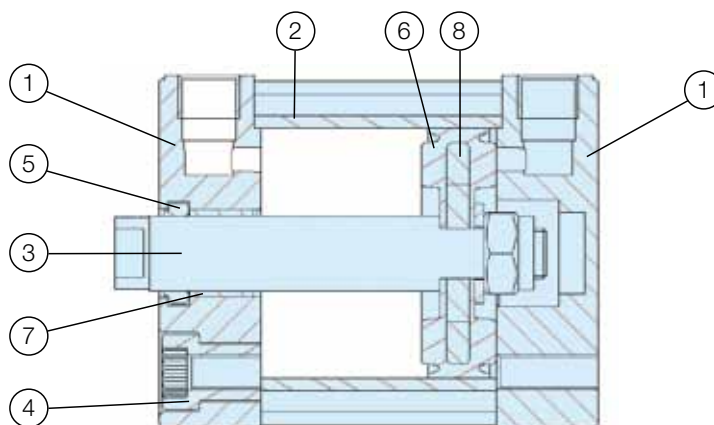

Pos	Part	Specification	
1	End covers	Anodised aluminium	
2	Cylinder barrel	Anodised aluminium	
3	Piston rod	Stainless steel, DIN X 10 CrNiS 18 9	
4	End cover screws	Zinc plated steel	
5	Piston rod seal	Standard	Polyurethane (PUR)
		High temperature	Flurocarbon rubber (FPM)
		Low temperature	Polyurethane (PUR)
6	Piston / piston seal	Standard	Aluminium / Nitrile rubber (NBR)
		High temperature	Aluminium / Hydrogenated nitrile rubber (HNBR)
		Low temperature	Aluminium / Nitrile rubber (NBR)
7	Piston rod bearing	Multilayer PTFE/steel	
8	Magnet	Plastic coated magnetic material	
	Note on materials	RoHS compliant	

Cylinder forces, double acting variants

Cylinder bore mm	Stroke	Bore mm	Piston rod mm	Max theoretical force in N (bar)											
				Area cm ²	1.0 bar	2.0 bar	3.0 bar	4.0 bar	5.0 bar	6.0 bar	7.0 bar	8.0 bar	9.0 bar	10.0 bar	
20	Double acting	+	20	10	3,1	31	63	94	126	157	188	220	251	283	314
		-	20	10	2,3	23	46	69	92	115	138	161	184	207	231
25	Double acting	+	25	10	4,9	49	98	147	196	245	295	344	393	442	491
		-	25	10	4,1	41	82	124	165	206	247	289	330	371	412
32	Double acting	+	32	12	8,0	80	161	241	322	402	483	563	643	724	804
		-	32	12	6,9	69	138	207	276	346	415	484	553	622	691
40	Double acting	+	40	12	12,6	126	251	377	503	628	754	880	1005	1131	1257
		-	40	12	11,4	114	229	343	457	572	686	800	915	1029	1144
50	Double acting	+	50	16	19,6	196	393	589	785	982	1178	1374	1571	1767	1963
		-	50	16	17,6	176	352	529	705	881	1057	1234	1410	1586	1762
63	Double acting	+	63	16	31,2	312	623	935	1247	1559	1870	2182	2494	2805	3117
		-	63	16	29,2	292	583	875	1166	1458	1750	2041	2333	2624	2916
80	Double acting	+	80	20	50,3	503	1005	1508	2011	2513	3016	3518	4021	4524	5026
		-	80	20	47,1	471	942	1414	1885	2356	2827	3299	3770	4241	4712
100	Double acting	+	100	25	78,5	785	1571	2356	3142	3927	4712	5498	6283	7069	7854
		-	100	25	73,6	736	1473	2209	2945	3682	4418	5154	5890	6627	7363

+ = Outward stroke

- = Return stroke

Note: Select a theoretical force 50-100% larger than the force required.

Technical data

Cylinder designation	Cylinder area bore		Piston rod area		Piston rod thread	Total mass		Air consumption litres ⁽¹⁾	Port size
	mm	cm ²	mm	cm ²		at 0 mm stroke kg	addition per 10 mm stroke kg		
P1PS...DS7G	Double acting with female piston rod thread								
P1PS020	20	3.1	10	0.78	M6 x 1.0	0.140	0.018	0.0405	M5
P1PS025	25	4.9	10	0.78	M6 x 1.0	0.170	0.022	0.0633	M5
P1PS032	32	8.0	12	1.1	M8 x 1.25	0.291	0.030	0.105	G1/8
P1PS040	40	12.6	12	1.1	M8 x 1.25	0.375	0.036	0.162	G1/8
P1PS050	50	19.6	16	2.0	M10 x 1.5	0.519	0.050	0.253	G1/8
P1PS063	63	31.2	16	2.0	M10 x 1.5	0.743	0.059	0.414	G1/8
P1PS080	80	50.3	20	3.1	M12 x 1.25	1.263	0.081	0.669	G1/8
P1PS100	100	78.5	25	4.9	M12 x 1.25	2.206	0.111	1.043	G1/8
P1PS...DS8G	Double acting with male piston rod thread								
P1PS020	20	3.1	10	0.78	M8 x 1.25	0.145	0.018	0.0405	M5
P1PS025	25	4.9	10	0.78	M8 x 1.25	0.179	0.022	0.0633	M5
P1PS032	32	8.0	12	1.1	M10 x 1.25	0.308	0.030	0.105	G1/8
P1PS040	40	12.6	12	1.1	M10 x 1.25	0.392	0.036	0.162	G1/8
P1PS050	50	19.6	16	2.0	M12 x 1.25	0.548	0.050	0.253	G1/8
P1PS063	63	31.2	16	2.0	M12 x 1.25	0.772	0.059	0.414	G1/8
P1PS080	80	50.3	20	3.1	M16 x 1.5	1.322	0.081	0.669	G1/8
P1PS100	100	50.3	25	4.9	M16 x 1.5	1.267	0.111	1.043	G1/8
P1PG...DS7G	Double acting with guided piston rod								
P1PG020	20	3.1	10	0.78	-	0.185	0.022	0.0405	M5
P1PG025	25	4.9	10	0.78	-	0.217	0.027	0.0633	M5
P1PG032	32	8.0	12	1.1	-	0.358	0.033	0.105	G1/8
P1PG040	40	12.6	12	1.1	-	0.455	0.039	0.162	G1/8
P1PG050	50	19.6	16	2.0	-	0.664	0.057	0.253	G1/8
P1PG063	63	31.2	16	2.0	-	0.930	0.067	0.414	G1/8
P1PG080	80	50.3	20	3.1	-	1.597	0.093	0.669	G1/8
P1PG100	100	50.3	25	4.9	-	1.679	0.123	1.043	G1/8

⁽¹⁾ Free air consumption per 10 mm stroke length for a double stroke at 6 bar

Selecting Pneumatic System Components

Cylinder to Valve: The below chart contains recommendations for selecting air valve products based on 5.5 bar with a 0.35 bar pressure drop. The values within the chart show the corresponding Cv values.

Moduflex Valve System

- Stand-alone valves, short-build valve manifold, or large valve manifold configurations available
- Cv range from 0.18 – 0.80
- Peripheral modules available— flow control, pressure regulation, P.O. check valves and vacuum generators



	20	25	32	40	50	63	80	100
50	0.01	0.02	0.03	0.04	0.06	0.10	0.16	0.26
100	0.02	0.03	0.05	0.08	0.13	0.20	0.33	0.51
150	0.03	0.05	0.08	0.12	0.19	0.30	0.49	0.77
200	0.04	0.06	0.10	0.16	0.26	0.41	0.65	1.02
250	0.05	0.08	0.13	0.20	0.32	0.51	0.82	1.28
300	0.06	0.10	0.16	0.25	0.38	0.61	0.98	1.53
350	0.07	0.11	0.18	0.29	0.45	0.71	1.15	1.79
400	0.08	0.13	0.21	0.33	0.51	0.81	1.31	2.04
450	0.09	0.14	0.24	0.37	0.58	0.91	1.47	2.30
500	0.10	0.16	0.26	0.41	0.64	1.01	1.64	2.56
	Size 1			Size 2		See Larger valve system		

Micro / ISO Valve System

- Isys Micro Cv range 0.30 – 0.35
- IsysNet system fieldbus, Turck system fieldbus, 25 pin D-sub, or low cost Moduflex fieldbus options available
- Isys ISO offers 5 sizes with Cv range 0.55 – 6.0



	20	25	32	40	50	63	80	100	Valve range
50	0.01	0.02	0.03	0.04	0.06	0.10	0.16	0.26	Isys Micro
100	0.02	0.03	0.05	0.08	0.13	0.20	0.33	0.51	HB
150	0.03	0.05	0.08	0.12	0.19	0.30	0.49	0.77	HA
200	0.04	0.06	0.10	0.16	0.26	0.41	0.65	1.02	H1
250	0.05	0.08	0.13	0.20	0.32	0.51	0.82	1.28	
300	0.06	0.10	0.16	0.25	0.38	0.61	0.98	1.53	
350	0.07	0.11	0.18	0.29	0.45	0.71	1.15	1.79	
400	0.08	0.13	0.21	0.33	0.51	0.81	1.31	2.04	
450	0.09	0.14	0.24	0.37	0.58	0.91	1.47	2.30	H2
500	0.10	0.16	0.26	0.41	0.64	1.01	1.64	2.56	

Order Code Key

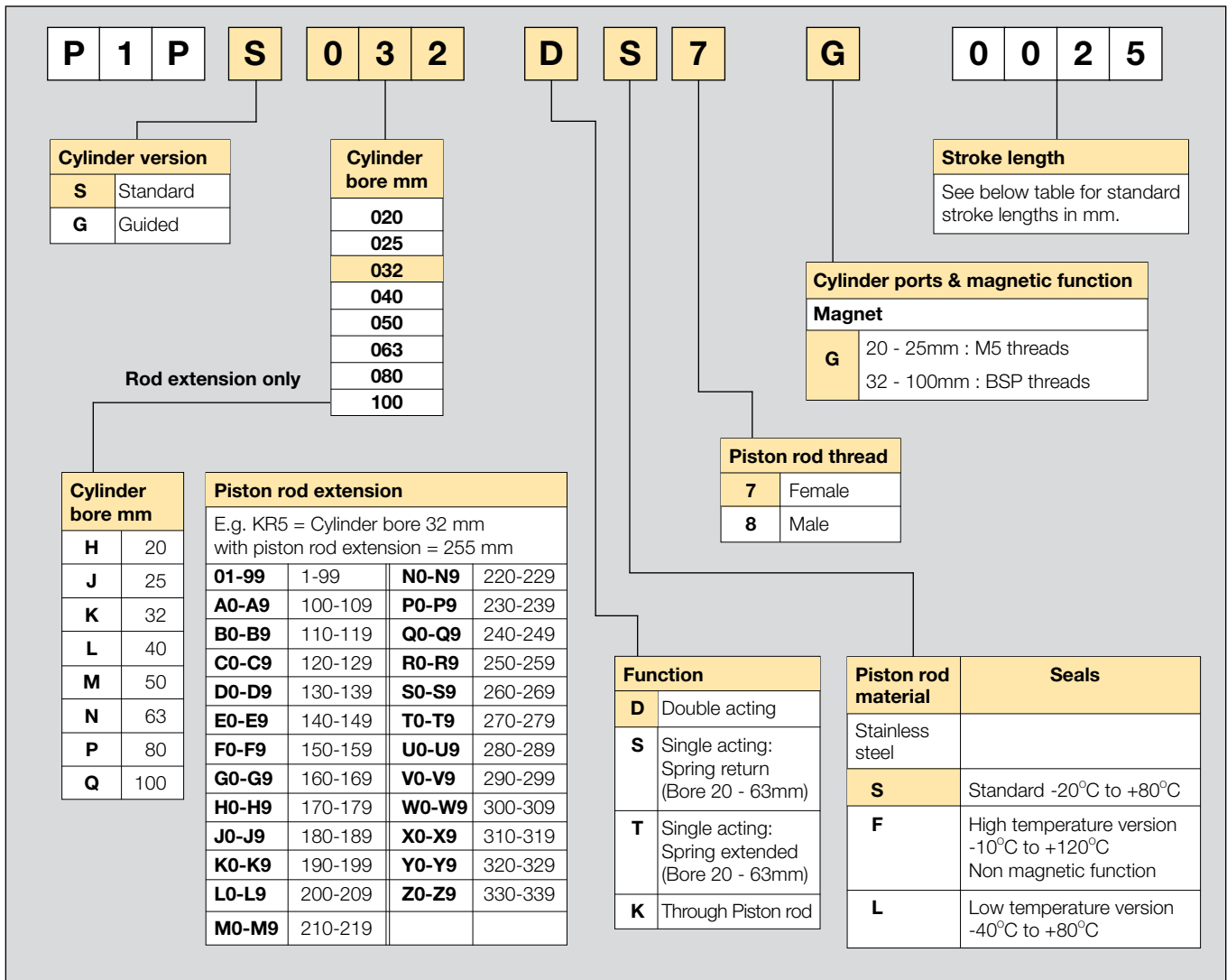

Standard stroke length

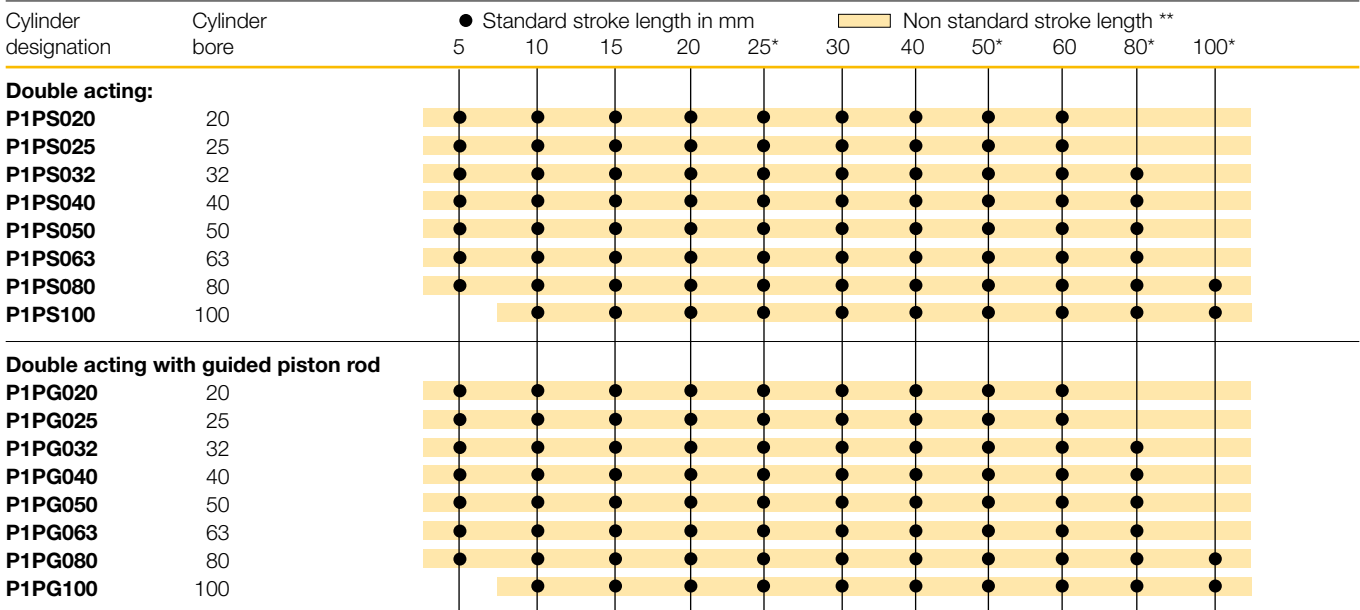

* Standard stroke lengths in mm according to ISO 4393

** Max stroke 500 mm

Double acting

The versatile high quality ISO compact cylinder range, P1P cylinders are up to 50% shorter than ISO1552 cylinders for the same stroke. Suitable for a wide range of applications.

- Bore 20 - 100 mm
- ISO 21287 conformity
- Corrosion resistant design and low weight construction
- Magnetic piston as standard
- Elastic cushioning
- Flexible direct mounting
- ISO 15552 mountings and global sensor range common with P1D



Double acting - Female threaded piston rod

Ø20mm - (M5)

Stroke mm	Order code
5	P1PS020DS7G0005
10	P1PS020DS7G0010
15	P1PS020DS7G0015
20	P1PS020DS7G0020
25	P1PS020DS7G0025
30	P1PS020DS7G0030
40	P1PS020DS7G0040
50	P1PS020DS7G0050
60	P1PS020DS7G0060

Ø25mm - (M5)

Stroke mm	Order code
5	P1PS025DS7G0005
10	P1PS025DS7G0010
15	P1PS025DS7G0015
20	P1PS025DS7G0020
25	P1PS025DS7G0025
30	P1PS025DS7G0030
40	P1PS025DS7G0040
50	P1PS025DS7G0050
60	P1PS025DS7G0060

Ø32mm - (G1/8)

Stroke mm	Order code
5	P1PS032DS7G0005
10	P1PS032DS7G0010
15	P1PS032DS7G0015
20	P1PS032DS7G0020
25	P1PS032DS7G0025
30	P1PS032DS7G0030
40	P1PS032DS7G0040
50	P1PS032DS7G0050
60	P1PS032DS7G0060
80	P1PS032DS7G0080

Ø40mm - (G1/8)

Stroke mm	Order code
5	P1PS040DS7G0005
10	P1PS040DS7G0010
15	P1PS040DS7G0015
20	P1PS040DS7G0020
25	P1PS040DS7G0025
30	P1PS040DS7G0030
40	P1PS040DS7G0040
50	P1PS040DS7G0050
60	P1PS040DS7G0060
80	P1PS040DS7G0080

Ø50mm - (G1/8)

Stroke mm	Order code
5	P1PS050DS7G0005
10	P1PS050DS7G0010
15	P1PS050DS7G0015
20	P1PS050DS7G0020
25	P1PS050DS7G0025
30	P1PS050DS7G0030
40	P1PS050DS7G0040
50	P1PS050DS7G0050
60	P1PS050DS7G0060
80	P1PS050DS7G0080

Ø63mm - (G1/8)

Stroke mm	Order code
5	P1PS063DS7G0005
10	P1PS063DS7G0010
15	P1PS063DS7G0015
20	P1PS063DS7G0020
25	P1PS063DS7G0025
30	P1PS063DS7G0030
40	P1PS063DS7G0040
50	P1PS063DS7G0050
60	P1PS063DS7G0060
80	P1PS063DS7G0080

Ø80mm - (G1/8)

Stroke mm	Order code
5	P1PS080DS7G0005
10	P1PS080DS7G0010
15	P1PS080DS7G0015
20	P1PS080DS7G0020
25	P1PS080DS7G0025
30	P1PS080DS7G0030
40	P1PS080DS7G0040
50	P1PS080DS7G0050
60	P1PS080DS7G0060
80	P1PS080DS7G0080
100	P1PS080DS7G0100

Ø100mm - (G1/8)

Stroke mm	Order code
10	P1PS100DS7G0010
15	P1PS100DS7G0015
20	P1PS100DS7G0020
25	P1PS100DS7G0025
30	P1PS100DS7G0030
40	P1PS100DS7G0040
50	P1PS100DS7G0050
60	P1PS100DS7G0060
80	P1PS100DS7G0080
100	P1PS100DS7G0100

Sensors

For sensors see page 25.

Compact ISO Cylinders - P1P Series

Double acting - Guided

This cylinder version feature twin guide rods connected to the piston rod by a large flange plate. These cylinders are ideal for clamping an moving applications where turning of the piston rod must be avoided.



Double acting - Guided

Ø20mm - (M5)

Stroke mm	Order code
5	P1PG020DS7G0005
10	P1PG020DS7G0010
15	P1PG020DS7G0015
20	P1PG020DS7G0020
25	P1PG020DS7G0025
30	P1PG020DS7G0030
40	P1PG020DS7G0040
50	P1PG020DS7G0050
60	P1PG020DS7G0060

Ø25mm - (M5)

Stroke mm	Order code
5	P1PG025DS7G0005
10	P1PG025DS7G0010
15	P1PG025DS7G0015
20	P1PG025DS7G0020
25	P1PG025DS7G0025
30	P1PG025DS7G0030
40	P1PG025DS7G0040
50	P1PG025DS7G0050
60	P1PG025DS7G0060

Ø32mm - (G1/8)

Stroke mm	Order code
5	P1PG032DS7G0005
10	P1PG032DS7G0010
15	P1PG032DS7G0015
20	P1PG032DS7G0020
25	P1PG032DS7G0025
30	P1PG032DS7G0030
40	P1PG032DS7G0040
50	P1PG032DS7G0050
60	P1PG032DS7G0060
80	P1PG032DS7G0080

Ø40mm - (G1/8)

Stroke mm	Order code
5	P1PG040DS7G0005
10	P1PG040DS7G0010
15	P1PG040DS7G0015
20	P1PG040DS7G0020
25	P1PG040DS7G0025
30	P1PG040DS7G0030
40	P1PG040DS7G0040
50	P1PG040DS7G0050
60	P1PG040DS7G0060
80	P1PG040DS7G0080

Ø50mm - (G1/8)

Stroke mm	Order code
5	P1PG050DS7G0005
10	P1PG050DS7G0010
15	P1PG050DS7G0015
20	P1PG050DS7G0020
25	P1PG050DS7G0025
30	P1PG050DS7G0030
40	P1PG050DS7G0040
50	P1PG050DS7G0050
60	P1PG050DS7G0060
80	P1PG050DS7G0080

Ø63mm - (G1/8)

Stroke mm	Order code
5	P1PG063DS7G0005
10	P1PG063DS7G0010
15	P1PG063DS7G0015
20	P1PG063DS7G0020
25	P1PG063DS7G0025
30	P1PG063DS7G0030
40	P1PG063DS7G0040
50	P1PG063DS7G0050
60	P1PG063DS7G0060
80	P1PG063DS7G0080

Ø80mm - (G1/8)

Stroke mm	Order code
5	P1PG080DS7G0005
10	P1PG080DS7G0010
15	P1PG080DS7G0015
20	P1PG080DS7G0020
25	P1PG080DS7G0025
30	P1PG080DS7G0030
40	P1PG080DS7G0040
50	P1PG080DS7G0050
60	P1PG080DS7G0060
80	P1PG080DS7G0080
100	P1PG080DS7G0100

Ø100mm - (G1/8)

Stroke mm	Order code
10	P1PG100DS7G0010
15	P1PG100DS7G0015
20	P1PG100DS7G0020
25	P1PG100DS7G0025
30	P1PG100DS7G0030
40	P1PG100DS7G0040
50	P1PG100DS7G0050
60	P1PG100DS7G0060
80	P1PG100DS7G0080
100	P1PG100DS7G0100

Sensors



For sensors see page 25.

Compact ISO Cylinders - P1P Series

Single acting

Single acting P1P cylinders are available in bore sizes 20 - 63 mm and in two versions to suit a wide range of applications. Choose between the spring return (SS) and the spring extended (TS) versions.



Single acting - Spring return - Female threaded piston rod

Ø20mm - (M5)

Stroke mm	Order code
25	P1PS020SS7G0025

Ø25mm - (M5)

Stroke mm	Order code
25	P1PS025SS7G0025

Ø32mm - (G1/8)

Stroke mm	Order code
25	P1PS032SS7G0025

Ø40mm - (G1/8)

Stroke mm	Order code
25	P1PS040SS7G0025

Ø50mm - (G1/8)

Stroke mm	Order code
25	P1PS050SS7G0025

Ø63mm - (G1/8)

Stroke mm	Order code
25	P1PS063SS7G0025



Single acting - Spring extended - Female threaded piston rod

Ø20mm - (M5)

Stroke mm	Order code
25	P1PS020TS7G0025

Ø25mm - (M5)

Stroke mm	Order code
25	P1PS025TS7G0025

Ø32mm - (G1/8)

Stroke mm	Order code
25	P1PS032TS7G0025

Ø40mm - (G1/8)

Stroke mm	Order code
25	P1PS040TS7G0025

Ø50mm - (G1/8)

Stroke mm	Order code
25	P1PS050TS7G0025

Ø63mm - (G1/8)

Stroke mm	Order code
25	P1PS063TS7G0025

Note: Within limits other stroke lengths close to above standard stroke can be realised with corresponding change of the spring force.

Sensors



For sensors see page 25.

Compact ISO Cylinders - P1P Series

Double acting - Through piston rod

The P1P through rod cylinder version is available in bore sizes 20 - 100 mm.

This cylinder type is used in many ways e.g. in applications with higher lateral forces or when performing a movement on both sides of the cylinder.



Double acting - Through piston rod - Female threaded piston rod

Ø20mm - (M5)

Stroke mm	Order code
5	P1PS020KS7G0005
10	P1PS020KS7G0010
15	P1PS020KS7G0015
20	P1PS020KS7G0020
25	P1PS020KS7G0025
30	P1PS020KS7G0030
40	P1PS020KS7G0040
50	P1PS020KS7G0050
60	P1PS020KS7G0060

Ø25mm - (M5)

Stroke mm	Order code
5	P1PS025KS7G0005
10	P1PS025KS7G0010
15	P1PS025KS7G0015
20	P1PS025KS7G0020
25	P1PS025KS7G0025
30	P1PS025KS7G0030
40	P1PS025KS7G0040
50	P1PS025KS7G0050
60	P1PS025KS7G0060

Ø32mm - (G1/8)

Stroke mm	Order code
5	P1PS032KS7G0005
10	P1PS032KS7G0010
15	P1PS032KS7G0015
20	P1PS032KS7G0020
25	P1PS032KS7G0025
30	P1PS032KS7G0030
40	P1PS032KS7G0040
50	P1PS032KS7G0050
60	P1PS032KS7G0060
80	P1PS032KS7G0080

Ø40mm - (G1/8)

Stroke mm	Order code
5	P1PS040KS7G0005
10	P1PS040KS7G0010
15	P1PS040KS7G0015
20	P1PS040KS7G0020
25	P1PS040KS7G0025
30	P1PS040KS7G0030
40	P1PS040KS7G0040
50	P1PS040KS7G0050
60	P1PS040KS7G0060
80	P1PS040KS7G0080

Ø50mm - (G1/8)

Stroke mm	Order code
5	P1PS050KS7G0005
10	P1PS050KS7G0010
15	P1PS050KS7G0015
20	P1PS050KS7G0020
25	P1PS050KS7G0025
30	P1PS050KS7G0030
40	P1PS050KS7G0040
50	P1PS050KS7G0050
60	P1PS050KS7G0060
80	P1PS050KS7G0080

Ø63mm - (G1/8)

Stroke mm	Order code
5	P1PS063KS7G0005
10	P1PS063KS7G0010
15	P1PS063KS7G0015
20	P1PS063KS7G0020
25	P1PS063KS7G0025
30	P1PS063KS7G0030
40	P1PS063KS7G0040
50	P1PS063KS7G0050
60	P1PS063KS7G0060
80	P1PS063KS7G0080

Ø80mm - (G1/8)

Stroke mm	Order code
5	P1PS080KS7G0005
10	P1PS080KS7G0010
15	P1PS080KS7G0015
20	P1PS080KS7G0020
25	P1PS080KS7G0025
30	P1PS080KS7G0030
40	P1PS080KS7G0040
50	P1PS080KS7G0050
60	P1PS080KS7G0060
80	P1PS080KS7G0080
100	P1PS080KS7G0100

Ø100mm - (G1/8)

Stroke mm	Order code
10	P1PS100KS7G0010
15	P1PS100KS7G0015
20	P1PS100KS7G0020
25	P1PS100KS7G0025
30	P1PS100KS7G0030
40	P1PS100KS7G0040
50	P1PS100KS7G0050
60	P1PS100KS7G0060
80	P1PS100KS7G0080
100	P1PS100KS7G0100

Sensors



For sensors see page 25.

Compact ISO Cylinders - P1P Series

Double acting - High temperature

Use this P1P cylinder version, available in bore sizes 20 - 100 mm, for high temperature applications with temperatures up to +120°C. The chemical resistance thanks to the design in anodised aluminium is an advantage in many high temperature applications. High temperature cylinders cannot be fitted with sensors (the magnetic field strength in high temperatures is too low to ensure correct reliable sensor function).



Double acting - High temperature - Female threaded piston rod

Ø20mm - (M5)

Stroke mm	Order code
5	P1PS020DF7G0005
10	P1PS020DF7G0010
15	P1PS020DF7G0015
20	P1PS020DF7G0020
25	P1PS020DF7G0025
30	P1PS020DF7G0030
40	P1PS020DF7G0040
50	P1PS020DF7G0050
60	P1PS020DF7G0060

Ø25mm - (M5)

Stroke mm	Order code
5	P1PS025DF7G0005
10	P1PS025DF7G0010
15	P1PS025DF7G0015
20	P1PS025DF7G0020
25	P1PS025DF7G0025
30	P1PS025DF7G0030
40	P1PS025DF7G0040
50	P1PS025DF7G0050
60	P1PS025DF7G0060

Ø32mm - (G1/8)

Stroke mm	Order code
5	P1PS032DF7G0005
10	P1PS032DF7G0010
15	P1PS032DF7G0015
20	P1PS032DF7G0020
25	P1PS032DF7G0025
30	P1PS032DF7G0030
40	P1PS032DF7G0040
50	P1PS032DF7G0050
60	P1PS032DF7G0060
80	P1PS032DF7G0080

Ø40mm - (G1/8)

Stroke mm	Order code
5	P1PS040DF7G0005
10	P1PS040DF7G0010
15	P1PS040DF7G0015
20	P1PS040DF7G0020
25	P1PS040DF7G0025
30	P1PS040DF7G0030
40	P1PS040DF7G0040
50	P1PS040DF7G0050
60	P1PS040DF7G0060
80	P1PS040DF7G0050

Ø50mm - (G1/8)

Stroke mm	Order code
5	P1PS050DF7G0005
10	P1PS050DF7G0010
15	P1PS050DF7G0015
20	P1PS050DF7G0020
25	P1PS050DF7G0025
30	P1PS050DF7G0030
40	P1PS050DF7G0040
50	P1PS050DF7G0050
60	P1PS050DF7G0060
80	P1PS050DF7G0080

Ø63mm - (G1/8)

Stroke mm	Order code
5	P1PS063DF7G0005
10	P1PS063DF7G0010
15	P1PS063DF7G0015
20	P1PS063DF7G0020
25	P1PS063DF7G0025
30	P1PS063DF7G0030
40	P1PS063DF7G0040
50	P1PS063DF7G0050
60	P1PS063DF7G0060
80	P1PS063DF7G0080

Ø80mm - (G1/8)

Stroke mm	Order code
5	P1PS080DF7G0005
10	P1PS080DF7G0010
15	P1PS080DF7G0015
20	P1PS080DF7G0020
25	P1PS080DF7G0025
30	P1PS080DF7G0030
40	P1PS080DF7G0040
50	P1PS080DF7G0050
60	P1PS080DF7G0060
80	P1PS080DF7G0080
100	P1PS080DF7G0100

Ø100mm - (G1/8)

Stroke mm	Order code
10	P1PS100DF7G0010
15	P1PS100DF7G0015
20	P1PS100DF7G0020
25	P1PS100DF7G0025
30	P1PS100DF7G0030
40	P1PS100DF7G0040
50	P1PS100DF7G0050
60	P1PS100DF7G0060
80	P1PS100DF7G0080
100	P1PS100DF7G0100

Compact ISO Cylinders - P1P Series

Double acting - Low temperature

This P1P cylinder version is developed for use in temperatures down to -40°C.

It is available in bore sizes 20 - 100 mm.

With the combination of compactness and corrosion resistance the P1P low temperature version can be used in many industries e.g.

Bus, Truck and Rail applications.



Double acting - Low temperature - Female threaded piston rod

Ø20mm - (M5)

Stroke mm	Order code
5	P1PS020DL7G0005
10	P1PS020DL7G0010
15	P1PS020DL7G0015
20	P1PS020DL7G0020
25	P1PS020DL7G0025
30	P1PS020DL7G0030
40	P1PS020DL7G0040
50	P1PS020DL7G0050
60	P1PS020DL7G0060

Ø25mm - (M5)

Stroke mm	Order code
5	P1PS025DL7G0005
10	P1PS025DL7G0010
15	P1PS025DL7G0015
20	P1PS025DL7G0020
25	P1PS025DL7G0025
30	P1PS025DL7G0030
40	P1PS025DL7G0040
50	P1PS025DL7G0050
60	P1PS025DL7G0060

Ø32mm - (G1/8)

Stroke mm	Order code
5	P1PS032DL7G0005
10	P1PS032DL7G0010
15	P1PS032DL7G0015
20	P1PS032DL7G0020
25	P1PS032DL7G0025
30	P1PS032DL7G0030
40	P1PS032DL7G0040
50	P1PS032DL7G0050
60	P1PS032DL7G0060
80	P1PS032DL7G0080

Ø40mm - (G1/8)

Stroke mm	Order code
5	P1PS040DL7G0005
10	P1PS040DL7G0010
15	P1PS040DL7G0015
20	P1PS040DL7G0020
25	P1PS040DL7G0025
30	P1PS040DL7G0030
40	P1PS040DL7G0040
50	P1PS040DL7G0050
60	P1PS040DL7G0040
80	P1PS040DL7G0050

Ø50mm - (G1/8)

Stroke mm	Order code
5	P1PS050DL7G0005
10	P1PS050DL7G0010
15	P1PS050DL7G0015
20	P1PS050DL7G0020
25	P1PS050DL7G0025
30	P1PS050DL7G0030
40	P1PS050DL7G0040
50	P1PS050DL7G0050
60	P1PS050DL7G0060
80	P1PS050DL7G0080

Ø63mm - (G1/8)

Stroke mm	Order code
5	P1PS063DL7G0005
10	P1PS063DL7G0010
15	P1PS063DL7G0015
20	P1PS063DL7G0020
25	P1PS063DL7G0025
30	P1PS063DL7G0030
40	P1PS063DL7G0040
50	P1PS063DL7G0050
60	P1PS063DL7G0060
80	P1PS063DL7G0080

Ø80mm - (G1/8)

Stroke mm	Order code
5	P1PS080DL7G0005
10	P1PS080DL7G0010
15	P1PS080DL7G0015
20	P1PS080DL7G0020
25	P1PS080DL7G0025
30	P1PS080DL7G0030
40	P1PS080DL7G0040
50	P1PS080DL7G0050
60	P1PS080DL7G0060
80	P1PS080DL7G0080
100	P1PS080DL7G0100

Ø100mm - (G1/8)

Stroke mm	Order code
10	P1PS100DL7G0010
15	P1PS100DL7G0015
20	P1PS100DL7G0020
25	P1PS100DL7G0025
30	P1PS100DL7G0030
40	P1PS100DL7G0040
50	P1PS100DL7G0050
60	P1PS100DL7G0060
80	P1PS100DL7G0080
100	P1PS100DL7G0100

Sensors



For sensors see page 25.

Dimensions - Bore 20 - 63mm

P1PS...DS7G Double acting with female piston rod thread

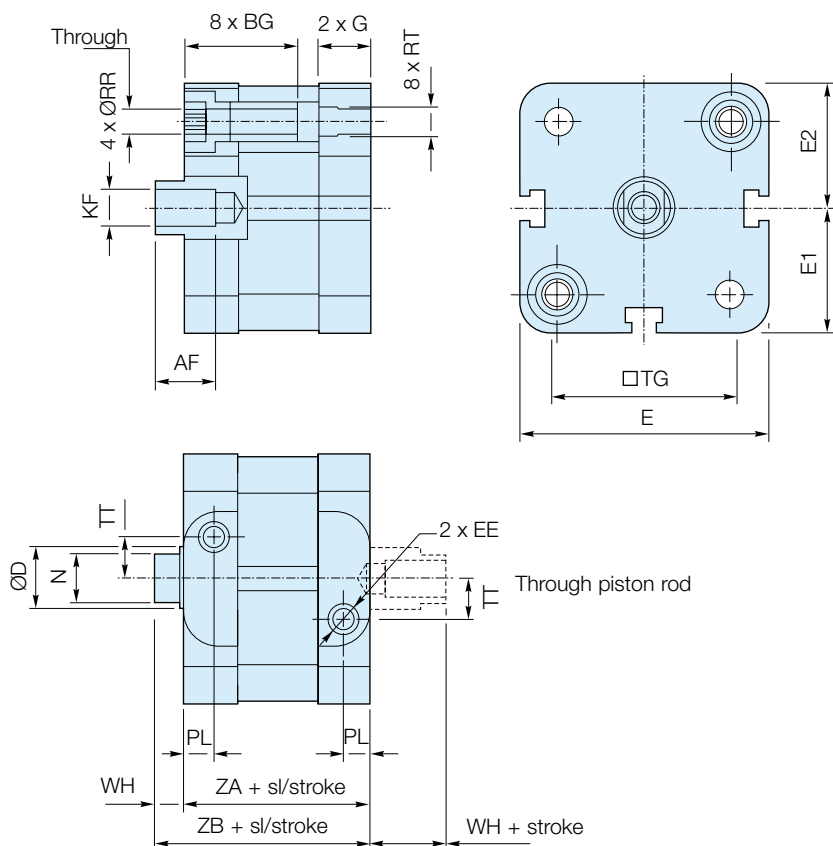

P1PG...DS Double acting with guided piston rod

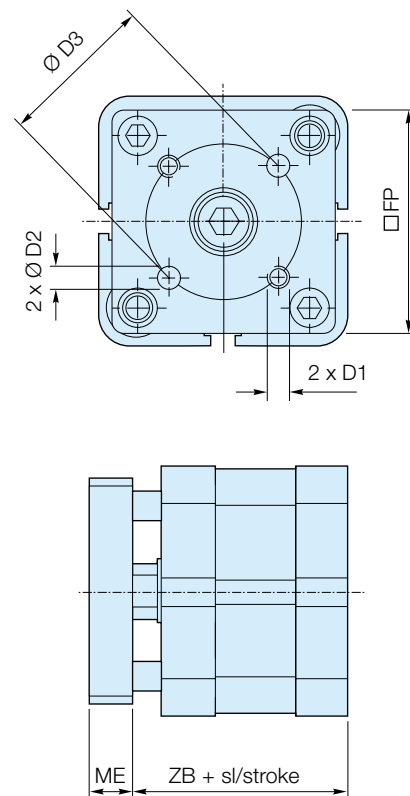

Bore size	AF min	BG min	ØD	D1	ØD2 H8	ØD3	EE	E	E1	E2	FP	G	KF	ME	N h14	PL	ØRR min	RT	TG	TT	WH	ZA ±0,3	ZB ±0,6
Ø20	10	15	10	M4	4	17	M5	38,0	19,0	19,1	35	11,60	M6	8	8	7,6	4,1	M5	22,0	4,0	6	37	43
Ø25	10	15	10	M5	5	22	M5	41,0	20,5	20,6	38	11,90	M6	8	8	7,5	4,1	M5	26,0	5,5	6	39	45
Ø32	12	16	12	M5	5	28	G1/8	49,4	24,7	24,9	45	15,25	M8	10	10	7,8	5,1	M6	32,5	6,5	7	44	51
Ø40	12	16	12	M5	5	33	G1/8	56,0	28,0	28,5	50	15,25	M8	10	10	8,0	5,1	M6	38,0	8,0	7	45	52
Ø50	16	16	16	M6	6	42	G1/8	67,0	33,5	33,7	60	14,30	M10	12	13	7,7	6,4	M8	46,5	11,0	8	45	53
Ø63	16	16	16	M6	6	50	G1/8	79,0	39,5	39,8	70	16,30	M10	12	13	8,0	6,4	M8	56,5	16,0	8	49	57

P1PS...DS8G Double acting with male piston rod thread

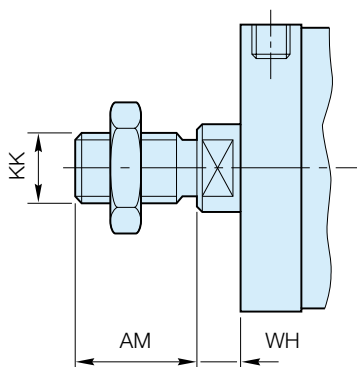

Bore size	AM	WH		KK
		nom.	tol.	
Ø20	16	6	± 1,6	M8 x 1,25
Ø25	16	6	± 1,6	M8 x 1,25
Ø32	19	7	± 1,6	M10 x 1,25
Ø40	19	7	± 1,6	M10 x 1,25
Ø50	22	8	± 1,6	M12 x 1,25
Ø63	22	8	± 1,6	M12 x 1,25

Note: Cylinders with male piston rod thread are delivered with one piston rod nut in zinc plated steel

For P1P Series product information and CAD visit www.parker.com/pde/p1p



Compact ISO Cylinders - P1P Series

Dimensions - Bore 80 - 100mm

P1PS...DS7G Double acting with female piston rod thread

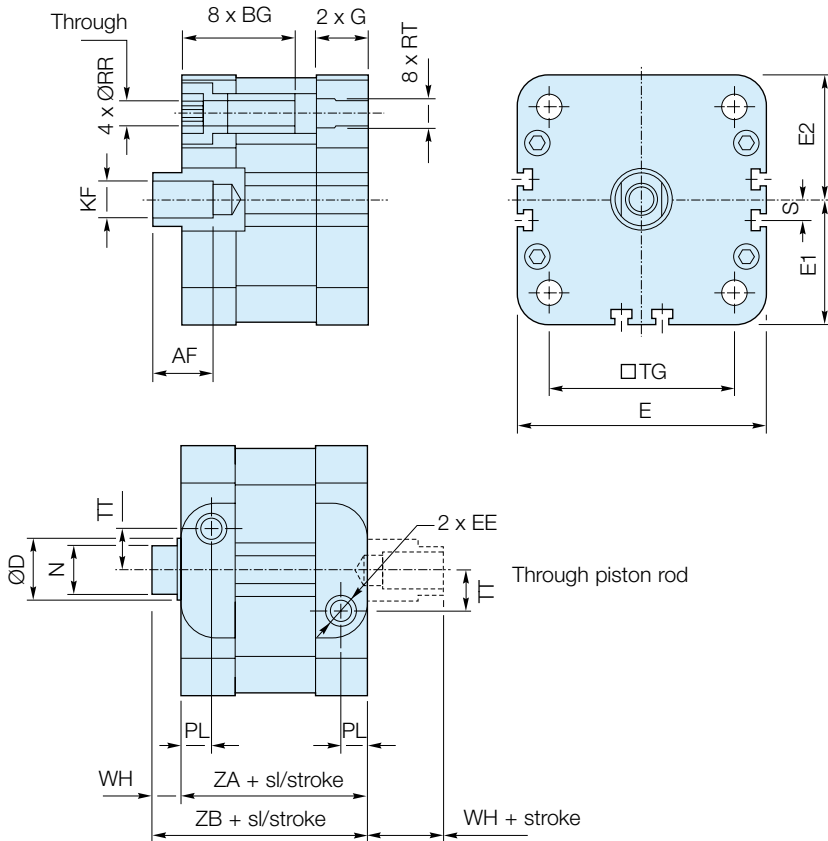

P1PG...DS Double acting with guided piston rod

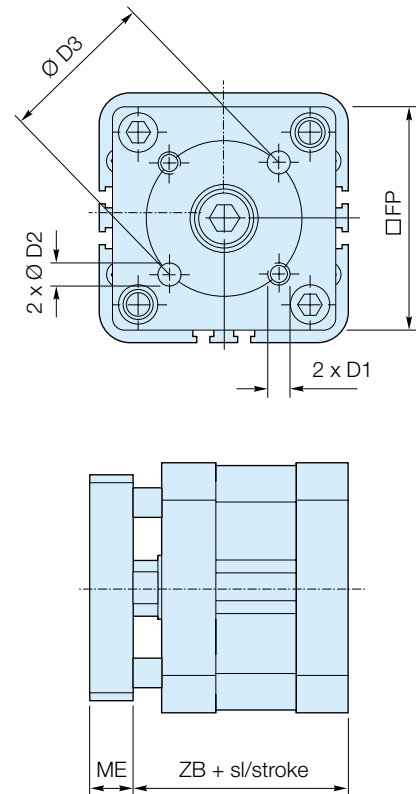

Bore size	AF min	BG min	ØD	D1	ØD2 H8	ØD3	EE	E	E1	E2	FP	G	KF	ME	N h14	PL	ØRR min	RT	S	TG	TT	WH ±0,3	ZA ±0,6	ZB
Ø80	20	17	20	M8	8	65	G1/8	96	48,0	48,2	90	17,7	M12	14	17	10,5	8,4	M10	8	72	20	10	54	64
Ø100	20	17	25	M10	10	80	G1/8	115	57,5	57,7	110	23,0	M12	14	21	12,0	8,4	M10	18,5	89	24	10	67	77

P1PS...DS8G Double acting with male piston rod thread

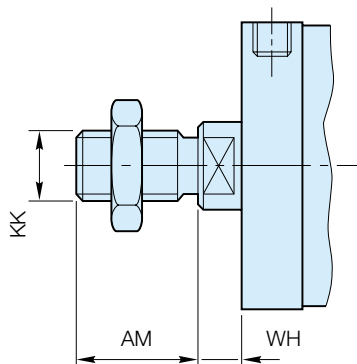

Bore size	AM	WH		KK
		nom.	tol.	
	0 -0.05			
Ø80	28	10	± 1,6	M16 x 1,5
Ø100	28	10	± 1,6	M16 x 1,5

Note: Cylinders with male piston rod thread are delivered with one piston rod nut in zinc plated steel

For P1P Series product information and CAD visit www.parker.com/pde/p1p

Compact ISO Cylinders - P1P Series

	Flange MF1 / MF2 ¹	Foot bracket MS1 ²	Pivot bracket with rigid bearing ³	Clevis bracket MP2 ⁴	Clevis bracket MP4 ⁵
Ø 20	P1P-4HMB	P1P-4HMF			P1P-4HME
Ø 25	P1P-4JMB	P1P-4JMF			P1P-4JME
Ø 32	P1C-4KMB	P1C-4KMF	P1C-4KMD	P1C-4KMT	P1C-4KME
Ø 40	P1C-4LMB	P1C-4LMF	P1C-4LMD	P1C-4LMT	P1C-4LME
Ø 50	P1C-4MMB	P1C-4MMF	P1C-4MMD	P1C-4MMT	P1C-4MME
Ø 63	P1C-4NMB	P1C-4NMF	P1C-4NMD	P1C-4NMT	P1C-4NME
Ø 80	P1C-4PMB	P1C-4PMF	P1C-4PMD	P1C-4PMT	P1C-4PME
Ø 100	P1C-4QMB	P1C-4QMF	P1C-4QMD	P1C-4QMT	P1C-4QME
	Clevis bracket GA ⁶	Pivot bracket with swivel bearing ⁷	Swivel eye bracket ⁸	Mounting kit	Swivel rod eye ¹⁰
Ø 20					P1A-4HRS
Ø 25					P1A-4HRS
Ø 32	P1C-4KMCA	P1C-4KMA	P1C-4KMSA	P1E-6KB0	P1C-4KRS
Ø 40	P1C-4LMCA	P1C-4LMA	P1C-4LMSA	P1E-6LB0	P1C-4KRS
Ø 50	P1C-4MMCA	P1C-4MMA	P1C-4MMSA	P1E-6MB0	P1C-4LRS
Ø 63	P1C-4NMCA	P1C-4NMA	P1C-4NMSA	P1E-6NB0	P1C-4LRS
Ø 80	P1C-4PMCA	P1C-4PMA	P1C-4PMSA	P1E-6PB0	P1C-4MRS
Ø 100	P1C-4QMCA	P1C-4QMA	P1C-4QMSA	P1E-6QB0	P1C-4MRS
	Clevis ¹¹	Flexo coupling ¹²	Nut (Pack of 10 off)		
Ø 20	P1A-4HRC	P1C-4HRF	P14-4HRPZ		
Ø 25	P1A-4HRC	P1C-4HRF	P14-4HRPZ		
Ø 32	P1C-4KRC	P1C-4KRF	P14-4KRPZ		
Ø 40	P1C-4KRC	P1C-4KRF	P14-4KRPZ		
Ø 50	P1C-4LRC	P1C-4LRF	P14-4LRPZ		
Ø 63	P1C-4LRC	P1C-4LRF	P14-4LRPZ		
Ø 80	P1C-4MRC	P1C-4MRF	P14-4MRPZ		
Ø 100	P1C-4MRC	P1C-4MRF	P14-4MRPZ		

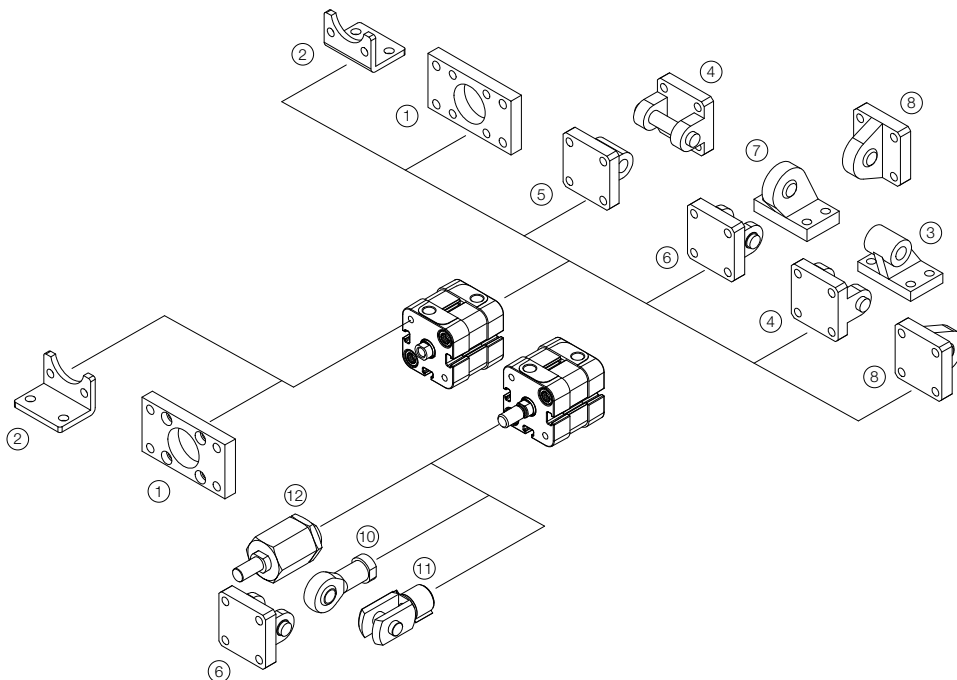

Compact ISO Cylinders - P1P Series

Cylinder mountings

Flange MF1/MF2



Intended for fixed mounting of cylinder. Flange can be fitted to front- or rear end-plates of cylinder.

Materials
 Flange: Surface-treated steel
 Mounting screws according to DIN 6912: Zinc-plated steel 8.8

Supplied complete with mounting screws for attachment to cylinder.

Ø32-100 according to ISO MF1/MF2, VDMA, AFNOR

Cyl. bore mm	d1 mm	FB mm	TG1 mm	E mm	R mm	MF mm	TF mm	UF mm	I1 mm	W mm	ZF* mm	ZB* mm
20	12,0	6,6	22,0	36	-	10,0	55,0	70	5,4	4,0	53,0	43,0
25	12,0	6,6	26,0	40	-	10,0	60,0	76	5,4	4,0	55,0	45,0
32	30,0	7,0	32,5	45	32	10,0	64,0	80	5,0	3,0	61,0	41,0
40	35,0	9,0	38,0	52	36	10,0	72,0	90	5,0	3,0	52,0	52,0
50	40,0	9,0	46,5	65	45	12,0	90,0	110	6,5	4,0	65,0	53,0
63	45,0	9,0	56,5	75	50	12,0	100,0	120	6,5	4,0	69,0	57,0
80	45,0	12,0	72,0	95	63	16,0	126,0	150	8,0	6,0	80,0	64,0
100	55,0	14,0	89,0	115	75	16,0	150,0	170	8,0	6,0	93,0	77,0

S = Stroke length

Cyl. bore Ø mm	Weight kg	Order code
20	0,17	P1P-4HMB
25	0,20	P1P-4JMB
32	0,23	P1C-4KMB
40	0,28	P1C-4LMB
50	0,53	P1C-4MMB
63	0,71	P1C-4NMB
80	1,59	P1C-4PMB
100	2,19	P1C-4QMB

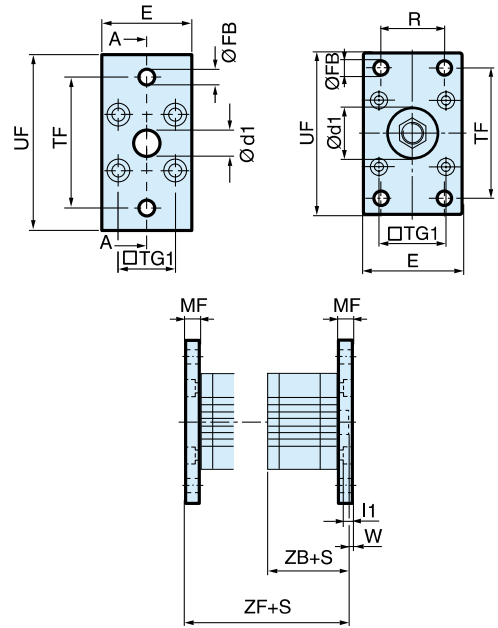

Foot bracket MS1



Intended for fixed mounting of cylinder. Angle bracket can be fitted to front- and rear end-plates of cylinder.

Materials
 Foot bracket: Surface-treated steel
 Mounting screws according to DIN 912:
 Zinc-plated steel 8.8

Supplied in pairs with mounting screws for attachment to cylinder.

Cyl. bore Ø mm	Weight kg	Order code
20	0,04**	P1P-4HMF
25	0,05**	P1P-4JMF
32	0,06**	P1C-4KMF
40	0,08**	P1C-4LMF
50	0,16**	P1C-4MMF
63	0,25**	P1C-4NMF*
80	0,50**	P1C-4PMF
100	0,85**	P1C-4QMF*

** Weight per item

Ø32-63 according to ISO MS1, VDMA, AFNOR

Cyl. bore mm	AB mm	TG1 mm	E mm	TR mm	AO mm	AU mm	AH mm	I7 mm	AT mm	I9 mm	SA** mm
20	6,6	22,0	36	26	6,0	16,0	27	22,0	4,0	17,0	69,0
25	6,6	26,0	40	26	6,0	16,0	30	23,0	4,0	19,0	71,0
32	7,0	32,5	45	32	10,0	24,0	32	30,0	4,5	17,5	92,0
40	9,0	38,0	52	36	8,0	28,0	36	30,0	4,5	18,5	101,0
50	9,0	46,5	65	45	13,0	32,0	45	36,0	5,5	25,0	109,0
63	9,0	56,5	75	50	13,0	32,0	50	35,0	5,5	27,5	113,0
80	12,0	72,0	95	63	14,0	41,0	63	49,0	6,5	40,5	136,0
100	14,0	89,0	115	75	15,0	41,0	71	54,0	6,5	43,5	149,0

S = Stroke length

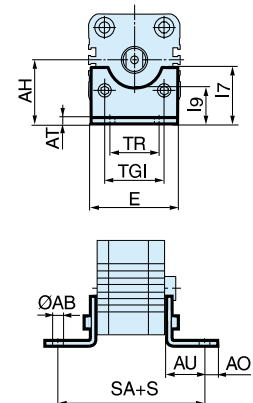

Cylinder mountings

Pivot bracket with rigid bearing



Intended for flexible mounting of cylinder. The pivot bracket can be combined with clevis bracket MP2.

Materials
 Pivot bracket: Surface-treated aluminium, black
 Bearing: Sintered oil-bronze bushing

Cyl. bore Ø mm	Weight kg	Order code
32	0,06	P1C-4KMD
40	0,08	P1C-4LMD
50	0,15	P1C-4MMD
63	0,20	P1C-4NMD
80	0,33	P1C-4PMD
100	0,49	P1C-4QMD

According to CETOP RP 107 P, VDMA, AFNOR

Cyl. bore mm	CK H9 mm	S5 H13 mm	K1 JS14 mm	K2 mm	G1 JS14 mm	G2 JS14 mm	EM mm	G3 mm	CA JS15 mm	H6 mm	R1 mm
32	10	6,6	38	51	21	18	25,5	31	32	8	10
40	12	6,6	41	54	24	22	27,0	35	36	10	11
50	12	9,0	50	65	33	30	31,0	45	45	12	13
63	16	9,0	52	67	37	35	39,0	50	50	12	15
80	16	11,0	66	86	47	40	49,0	60	63	14	15
100	20	11,0	76	96	55	50	59,0	70	71	15	19

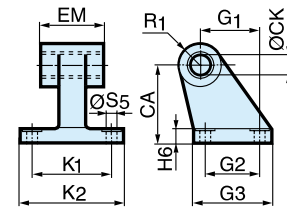

Clevis bracket MP2



Intended for flexible mounting of cylinder. Clevis bracket MP2 can be combined with clevis bracket MP4.

Materials
 Clevis bracket: Surface-treated aluminium, black
 Mounting screws according to DIN 912:
 Zinc-plated steel 8.8
 Pin: surface treated steel

Supplied complete with mounting screws for attachment to cylinder.

Cyl. bore Ø mm	Weight kg	Order code
32	0,08	P1C-4KMT
40	0,11	P1C-4LMT
50	0,14	P1C-4MMT
63	0,29	P1C-4NMT
80	0,36	P1C-4PMT
100	0,64	P1C-4QMT

According to ISO MP2, VDMA, AFNOR

Cyl. bore mm	E mm	UB h14 mm	CB H14 mm	FL ±0,2 mm	L mm	l2 mm	CD H9 mm	MR mm	XD* mm
32	45,0	45	26,0	22	13	5,5	10	10	73,0
40	52,0	52	28,0	25	16	5,5	12	12	77,0
50	65,0	60	32,0	27	16	6,5	12	12	80,0
63	75,0	70	40,0	32	21	6,5	16	16	89,0
80	95,0	90	50,0	36	22	10,0	16	16	100,0
100	115,0	110	60,0	41	27	10,0	20	20	118,0

S = Stroke length

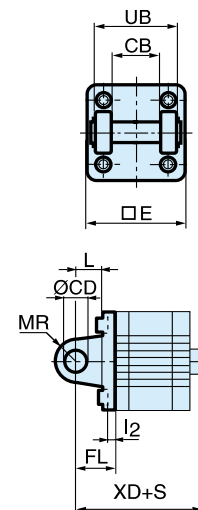

Cylinder mountings

Clevis bracket MP4

Intended for flexible mounting of cylinder. Clevis bracket MP4 can be combined with clevis bracket MP2.



Materials
 Clevis bracket: Surface-treated aluminium, black
 Mounting screws according to DIN 912: Zinc-plated steel 8.8

Supplied complete with mounting screws for attachment to cylinder.

Ø32-100 according to ISO MP4, VDMA, AFNOR

Cyl. bore mm	E mm	EW mm	FL mm	L mm	I2 mm	CD mm	MR mm	XD* mm
20	34,0	16,0	±0,2 20	14	2,6	8	8	63,0
25	38,0	16,0	20	14	2,6	8	8	65,0
32	45,0	26,0	22	13	5,5	10	10	73,0
40	52,0	28,0	25	16	5,5	12	12	77,0
50	65,0	32,0	27	16	6,5	12	12	80,0
63	75,0	40,0	32	21	6,5	16	16	89,0
80	95,0	50,0	36	22	10,0	16	16	100,0
100	115,0	60,0	41	27	10,0	20	20	118,0

S = Stroke length

Cyl. bore Ø mm	Weight kg	Order code
20	0,04	P1P-4HME
25	0,05	P1P-4JME
32	0,09	P1C-4KME
40	0,13	P1C-4LME
50	0,17	P1C-4MME
63	0,36	P1C-4NME
80	0,46	P1C-4PME
100	0,83	P1C-4QME

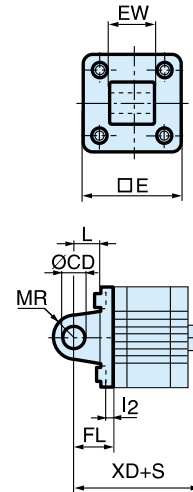

Clevis bracket GA

Intended for flexible mounting of cylinder. Clevis bracket GA can be combined with pivot bracket with swivel bearing, swivel eye bracket and swivel rod eye.



Materials
 Clevis bracket: Surface-treated aluminium, black
 Pin: Surface hardened steel
 Locking pin: Spring steel
 Circlips according to DIN 471: Spring steel
 Mounting screws acc. to DIN 912: Zinc-plated steel 8.8

Supplied complete with mounting screws for attachment to cylinder.

According to VDMA, AFNOR

Cyl. bore mm	E mm	B2 mm	B1 mm	T mm	B3 mm	R2 mm	L1 mm	FL mm	I2 mm	L mm	CN mm	R1 mm	XD* mm
32	45	34	14	3	3,3	17	11,5	±0,2 22	5,5	12	10	11	73,0
40	52	40	16	4	4,3	20	12,0	25	5,5	15	12	13	77,0
50	65	45	21	4	4,3	22	14,0	27	6,5	17	16	18	80,0
63	75	51	21	4	4,3	25	14,0	32	6,5	20	16	18	89,0
80	95	65	25	4	4,3	30	16,0	36	10,0	20	20	22	100,0
100	115	75	25	4	4,3	32	16,0	41	10,0	25	20	22	118,0

S = Stroke length

Cyl. bore Ø mm	Weight kg	Order code
32	0,09	P1C-4KMCA
40	0,13	P1C-4LMCA
50	0,17	P1C-4MMCA
63	0,36	P1C-4NMCA
80	0,58	P1C-4PMCA
100	0,89	P1C-4QMCA

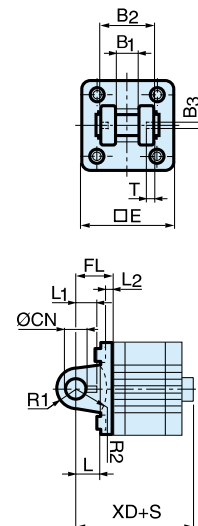

Stainless steel Pin Set GA

Materials
 Pin: Stainless steel
 Locking pin: Stainless steel
 Circlips according to DIN 471: Stainless steel

Cyl. bore Ø mm	Weight kg	Order code
32	0,05	9301054311
40	0,06	9301054312
50	0,07	9301054313
63	0,07	9301054314
80	0,17	9301054315
100	0,31	9301054316

Cylinder mountings

Pivot bracket with swivel bearing



Intended for use together with clevis bracket GA.

Material
 Pivot bracket: Surface-treated steel, black
 Swivel bearing according to DIN 648K: Hardened steel

Cyl. bore Ø mm	Weight kg	Order code
32	0,18	P1C-4KMA
40	0,25	P1C-4LMA
50	0,47	P1C-4MMA
63	0,57	P1C-4NMA
80	1,05	P1C-4PMA
100	1,42	P1C-4QMA

According to VDMA, AFNOR

Cyl. bore mm	CN H7 mm	S5 H13 mm	K1 JS14 mm	K2 mm	EU mm	G1 JS14 mm	G2 JS14 mm	EN mm	G3 mm	CH JS15 mm	H6 mm	ER mm	Z mm
32	10	6,6	38	51	10,5	21	18	14	31	32	10	16	4°
40	12	6,6	41	54	12,0	24	22	16	35	36	10	18	4°
50	16	9,0	50	65	15,0	33	30	21	45	45	12	21	4°
63	16	9,0	52	67	15,0	37	35	21	50	50	12	23	4°
80	20	11,0	66	86	18,0	47	40	25	60	63	14	28	4°
100	20	11,0	76	96	18,0	55	50	25	70	71	15	30	4°

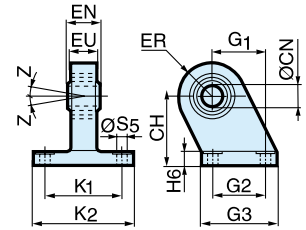

Swivel eye bracket



Intended for use together with clevis bracket GA

Material
 Bracket: Surface-treated aluminium, black
 Swivel bearing acc. to DIN 648K: Hardened steel

Supplied complete with mounting screws for attachment to cylinder.

Cyl. bore Ø mm	Weight kg	Order code
32	0,08	P1C-4KMSA
40	0,11	P1C-4LMSA
50	0,20	P1C-4MMSA
63	0,27	P1C-4NMSA
80	0,52	P1C-4PMSA
100	0,72	P1C-4QMSA

According to VDMA, AFNOR

Cyl. bore mm	E mm	B1 mm	B2 mm	EN mm	R1 mm	R2 mm	FL mm	I2 mm	L mm	CN H7 mm	XD* mm	Z mm
32	45	10,5	38	14	16	14	22	5,5	12	10	73,0	4°
40	52	12,0	44	16	18	16	25	5,5	15	12	77,0	4°
50	65	15,0	51	21	21	19	27	6,5	15	16	80,0	4°
63	75	15,0	56	21	23	22	32	6,5	20	16	89,0	4°
80	95	18,0	-	25	29	-	36	10,0	20	20	100,0	4°
100	115	18,0	-	25	31	-	41	10,0	25	20	118,0	4°

S=Stroke length

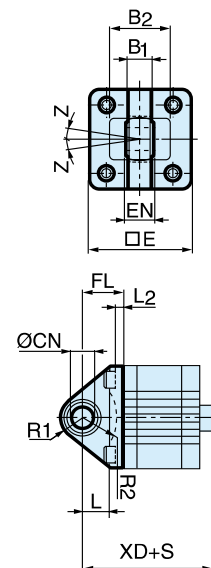

Cylinder mountings

Mounting kit



Mounting kit for back to back mounted cylinders,
3 and 4 position cylinders.

Material:
Mounting: Aluminium
Mounting screws: Zinc-plated steel 8.8

Cyl. bore mm	E mm	TG mm	ØFB mm	MF mm	A mm	ØBA mm
32	50	32,5	6,5	5	16	30
40	60	38,0	6,5	5	16	35
50	66	46,5	8,5	6	20	40
63	80	56,5	8,5	6	20	45
80	100	72,0	10,5	8	25	45
100	118	89,0	10,5	8	25	55

Cyl. bore Ø mm	Weight kg	Order code
32	0,060	P1E-6KB0
40	0,078	P1E-6LB0
50	0,162	P1E-6MB0
63	0,194	P1E-6NB0
80	0,450	P1E-6PB0
100	0,672	P1E-6QB0

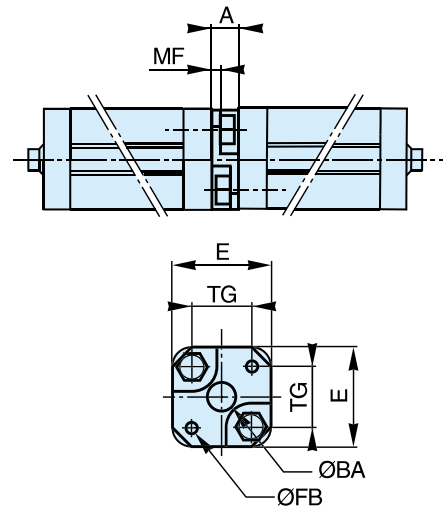

Piston rod mountings

Swivel rod eye



Swivel rod eye for articulated mounting of cylinder. Swivel rod eye can be combined with clevis bracket GA. Maintenance-free.

Materials
 Swivel rod eye: Zinc-plated steel
 Swivel bearing according to DIN 648K: Hardened steel

Stainless steel swivel rod eye



Stainless-steel swivel rod eye for articulated mounting of cylinder. Swivel rod eye can be combined with clevis bracket GA. Maintenance-free.

Materials
 Swivel rod eye: Stainless steel
 Swivel bearing according to DIN 648K: Stainless steel

Use stainless steel nut with stainless steel swivel rod eye.

Cyl. bore Ø mm	Weight kg	Order code
20 / 25	0,045	P1A-4HRS
32 / 40	0,08	P1C-4KRS
50 / 63	0,12	P1C-4LRS
80 / 100	0,25	P1C-4MRS

Cyl. bore Ø mm	Weight kg	Order code
20 / 25	0,045	P1S-4HRT
32 / 40	0,08	P1S-4JRT
50 / 63	0,12	P1S-4LRT
80 / 100	0,25	P1S-4MRT

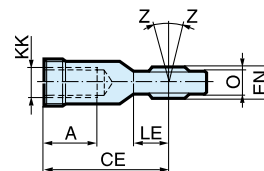
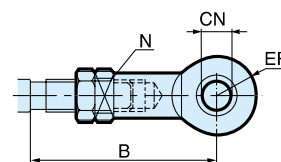

According to ISO 8139

Cyl. bore mm	A mm	B min max mm	B max mm	CE mm	CN H9 mm	EN h12 mm	ER mm	KK mm	LE mm	N min mm	O mm	Z °
20 / 25	12	40,0	45	36	8	12	12	M8x1,25	12	13	9,0	12°
32 / 40	20	48,0	55	43	10	14	14	M10x1,25	15	17	10,5	12°
50 / 63	22	56,0	62	50	12	16	16	M12x1,25	17	19	12,0	12°
80 / 100	28	72,0	80	64	16	21	21	M16x1,5	22	22	15,0	15°

Clevis



Clevis for articulated mounting of cylinder.

Material
 Clevis, clip: Galvanized steel
 Pin: Hardened steel

Cyl. bore Ø mm	Weight kg	Order code
20 / 25	0,045	P1A-4HRC
32 / 40	0,09	P1C-4KRC
50 / 63	0,15	P1C-4LRC
80 / 100	0,35	P1C-4MRC

Stainless steel clevis



Stainless-steel clevis for articulated mounting of cylinder.

Material
 Clevis: Stainless steel
 Pin: Stainless steel
 Circlips according to DIN 471: Stainless steel

Use stainless steel nut with stainless steel swivel rod eye.

Cyl. bore Ø mm	Weight kg	Order code
20 / 25	0,045	P1S-4HRD
32 / 40	0,09	P1S-4JRD
50 / 63	0,15	P1S-4LRD
80 / 100	0,35	P1S-4MRD

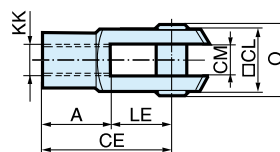
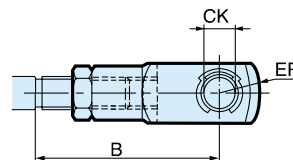

According to ISO 8140

Cyl. bore mm	A mm	B min max mm	B max mm	CE mm	CK h11/E9 mm	CL mm	CM mm	ER mm	KK mm	LE mm	O mm
20 / 25	16	36,0	41	32	8	16	8	-	M8x1,25	16	24,0
32 / 40	20	45,0	52	40	10	20	10	16	M10x1,25	20	28,0
50 / 63	24	54,0	60	48	12	24	12	19	M12x1,25	24	32,0
80 / 100	32	72,0	80	64	16	32	16	25	M16x1,5	32	41,5

Piston rod mountings

Flexo coupling



Flexo coupling for articulated mounting of piston rod. Flexo fitting is intended to take up axial angle errors within a range of $\pm 4^\circ$.

Material
Flexo coupling, nut: Zinc-plated steel

Supplied complete with galvanized adjustment nut.

Cyl. bore Ø mm	Weight kg	Order code
20 / 25	0,06	P1C-4JRF
32 / 40	0,23	P1C-4KRF
50 / 63	0,23	P1C-4LRF
80 / 100	0,65	P1C-4MRF

Cyl. bore mm	KK mm	B mm	C mm	D mm	E mm	ØF mm	SW1 mm	SW2 mm	SW3 mm	SW4 mm	SW5 mm
20 / 25	M8x1.25	16	14	55	20	12.4	7	17	17	10	13
32 / 40	M10x1.25	20	23	73	31	21	12	30	30	19	17
50 / 63	M12x1.5	24	23	77	31	21	12	30	30	19	19
80 / 100	M16x1.5	32	32	108	45	33.5	19	41	41	30	24

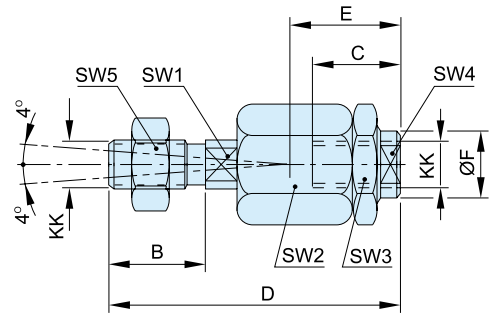

Nut



Intended for fixed mounting of accessories to the piston rod. Material: Zinc-plated steel

All P1D cylinders are delivered with a zinc-plated steel piston rod nut.

Supplied as pack of 10 off

Cyl. bore Ø mm	Weight * kg	Order code
20 / 25	0,005	P14-4HRPZ
32 / 40	0,007	P14-4KRPZ
50 / 63	0,021	P14-4LRPZ
80 / 100	0,040	P14-4MRPZ

* Weight per item

Stainless steel nut



Intended for fixed mounting of accessories to the piston rod.

Material: Stainless steel A2

All P1D cylinders are delivered with a zinc-plated steel piston rod nut.

Supplied as pack of 10 off

Cyl. bore Ø mm	Weight * kg	Order code
20 / 25	0,005	P14-4HRPS
32 / 40	0,007	P14-4KRPS
50 / 63	0,021	P14-4LRPS
80 / 100	0,040	P14-4MRPS

* Weight per item

According to DIN 439 B

Cyl. bore mm	d	M	S
20 / 25	M8x1,25		
32 / 40	M10x1,25	5,0	17
50 / 63	M12x1,25	6,0	19
80 / 100	M16x1,5	10,0	30

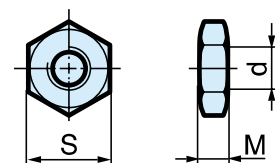

Drop-in sensors

The "drop-in" sensors can easily be installed from the side in the sensor groove, at any position along the piston stroke.

The sensors are completely recessed and thus mechanically protected. Choose between electronic or reed sensors and several cable lengths and 8 mm and M12 connectors.

The same standard sensors are used for all versions.

Please note that for low temperature applications sensors are normally specified for full performance down to -25°C only. High temperature cylinders do not have a magnetic ring in the piston and therefore cannot be used with sensors.



Electronic sensors

The electronic sensors are "Solid State", i.e. they have no moving parts at all. They are provided with short-circuit protection and transient protection as standard. The built-in electronics make the sensors suitable for applications with high on and off switching frequency, and where very long service life is required.

Reed sensors

The sensors are based on proven reed switches, which offer reliable function in many applications. Simple installation, a protected position on the cylinder and clear LED indication are important advantages of this range of sensors.

Technical data

Design	GMR (Giant Magnetic Resistance) magneto-resistive function
Installation	From side, down into the sensor groove, so-called drop-in
Outputs	PNP, normally open (also available in NPN design, normally closed, on request)
Voltage range	10-30 VDC 10-18 V DC, ATEX sensor
Ripple	max 10%
Voltage drop	max 2,5 V
Load current	max 100 mA
Internal consumption	max 10 mA
Actuating distance	min 9 mm
Hysteresis	max 1,5 mm
Repeatability accuracy	max 0,2 mm
On/off switching frequency	max 5 kHz
On switching time	max 2 ms
Off switching time	max 2 ms
Encapsulation	IP 67 (EN 60529)
Temperature range	-25 °C to +75 °C -20 °C to +45 °C, ATEX sensor
Indication	LED, yellow
Material housing	PA 12
Material screw	Stainless steel
Cable	PVC or PUR 3x0.25 mm ² see order code respectively

Technical data

Design	Reed element
Mounting	From side, down into the sensor groove, so-called drop-in
Output	Normally open , or normally closed
Voltage range	10-30 V AC/DC or 10-120 V AC/DC 24-230 V AC/DC
Load current	max 500 mA for 10-30 V or max 100 mA for 10-120 V max 30 mA for 24-230 V
Breaking power (resistive)	max 6 W/VA
Actuating distance	min 9 mm
Hysteresis	max 1,5 mm
Repeatability accuracy	0,2 mm
On/off switching frequency	max 400 Hz
On switching time	max 1,5 ms
Off switching time	max 0,5 ms
Encapsulation	IP 67 (EN 60529)
Temperature range	-25 °C to +75 °C
Indication	LED, yellow
Material housing	PA12
Material screw	Stainless steel
Cable	PVC or PUR 3x0.14 mm ² see order code respectively

Electronic sensors

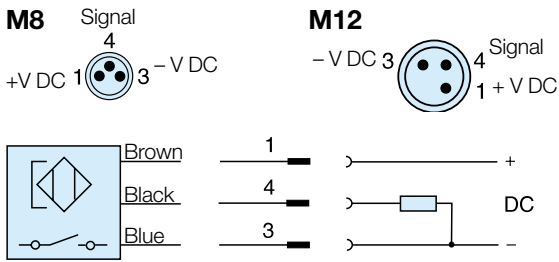

Reed sensors

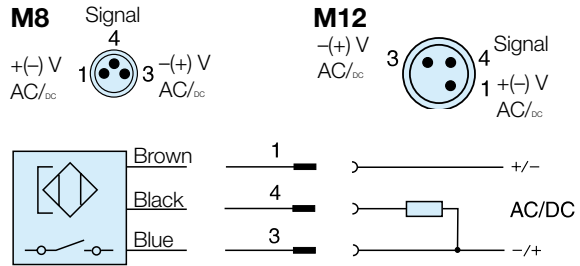

P8S-GCFPX

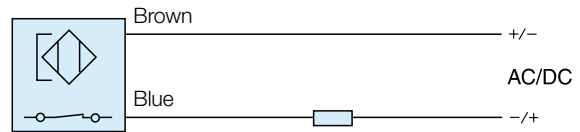

P8S-GRFLX / P8S-GRFLX2

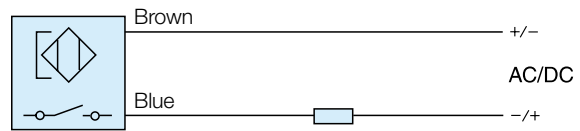

Dimensions

Sensors

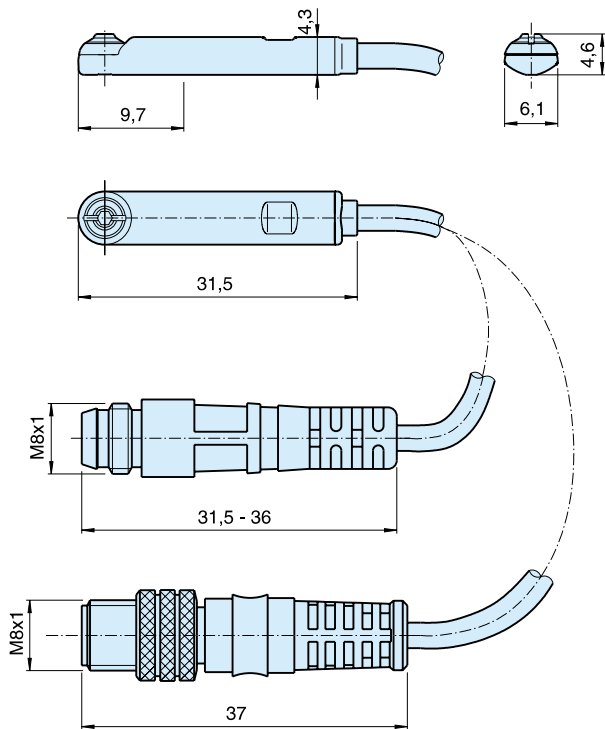

Sensor Installation

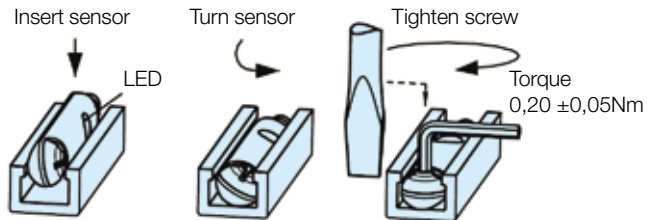

Ordering data

Output/function	Cable/connector	Weight kg	Order code
Electronic sensors , 10-30 V DC			
PNP type, normally open	0,27 m PUR-cable and 8 mm snap-in male connector	0,007	P8S-GPSHX
PNP type, normally open	0,27 m PUR-cable and M12 screw male connector	0,015	P8S-GPMHX
PNP type, normally open	3 m PVC-cable without connector	0,030	P8S-GPFLX
PNP type, normally open	10 m PVC-cable without connector	0,110	P8S-GPFTX
Reed sensors , 10-30 V AC/DC			
Normally open	0,27 m PUR-cable and 8 mm snap-in male connector	0,007	P8S-GSSHX
Normally open	0,27 m PUR-cable and M12 screw male connector	0,015	P8S-GSMHX
Normally open	3 m PVC-cable without connector	0,030	P8S-GSFLX
Normally open	10 m PVC-cable without connector	0,110	P8S-GSFTX
Normally closed	5m PVC-cable without connector ⁽¹⁾	0,050	P8S-GCFPX
Reed sensors, 10-120 V AC/DC			
Normally open	3 m PVC-cable without connector	0,030	P8S-GRFLX
Reed sensors 24-230 V AC/DC			
Normally open	3 m PVC-cable without connector	0,030	P8S-GRFLX2

1) Without LED

Connecting cables with one connector

The cables have an integral snap-in female connector.



Type of cable	Cable/connector	Weight kg	Order code
Cables for sensors, complete with one female connector			
Cable, Flex PVC	3 m 8 mm Snap-in connector	0,07	9126344341
Cable, Flex PVC	10 m 8 mm Snap-in connector	0,21	9126344342
Cable, Polyurethane	3 m 8 mm Snap-in connector	0,01	9126344345
Cable, Polyurethane	10 m 8 mm Snap-in connector	0,20	9126344346
Cable, Polyurethane	5 m M12 screw connector	0,07	9126344348
Cable, Polyurethane	10 m M12 screw connector	0,20	9126344349

Male connectors for connecting cables

Cable connectors for producing your own connecting cables. The connectors can be quickly attached to the cable without special tools. Only the outer sheath of the cable is removed. The connectors are available for M8 and M12 screw connectors and meet protection class IP 65.



Connector	Weight kg	Order code
M8 screw connector	0,017	P8CS0803J
M12 screw connector	0,022	P8CS1204J

P1P Repair Kits

Complete seal kits consist of:
 Piston (complete)
 Piston rod seal
 O rings



Material specification, see page 5

Order codes

Cyl.bore mm	P1P cylinder version		
	Std temp	High temp	Low temp
20	P1P-6HRN	P1P-6HRF	P1P-6HRL
25	P1P-6JRN	P1P-6JRF	P1P-6JRL
32	P1P-6KRN	P1P-6KRF	P1P-6KRL
40	P1P-6LRN	P1P-6LRF	P1P-6LRL
50	P1P-6MRN	P1P-6MRF	P1P-6MRL
63	P1P-6NRN	P1P-6NRF	P1P-6NRL
80	P1P-6PRN	P1P-6PRF	P1P-6PRL
100	P1P-6QRN	P1P-6QRF	P1P-6QRL

Order codes



Standard temperature	30g	9127394541
High temperature	30g	9127394521
Low temperature	30g	9127394541

For through rods variants, order two seal kits.

Example: For a P1PS...KS Ø63 through rod, standard temperature version, order 2 x **P1P-6NRN**

Seal kit

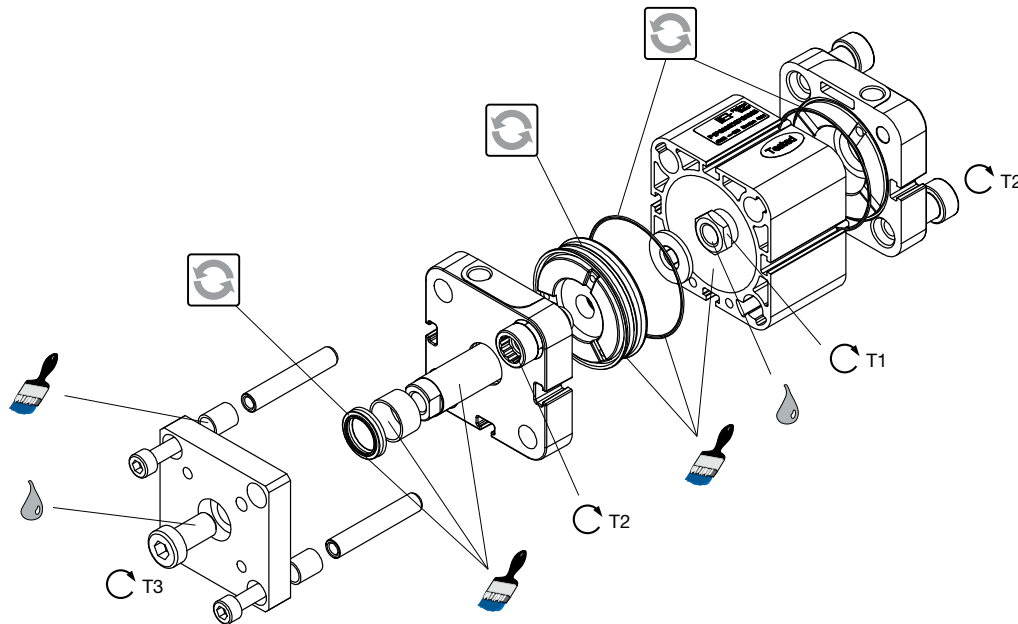

= Included in seal kit = Lubricated with grease

= Socket head = Locking fluid

= Tightening torque *Loctite 243 must be used for standard and low temperature versions.*
Loctite 270 must be used for high temperature versions

Cyl.-dia mm	Plastic piston T1 Nm	AF mm	T2 Nm	AF mm	T3 Nm	AF mm
20	3,5	8	14	7	8	4
25	3,5	8	14	7	8	4
32	8	10	20	7	20	5
40	12	13	20	7	20	5
50	20	17	40	10	40	7
63	20	17	40	10	40	7
80	35	19	14	5	70	8
100	80	24	28	6	70	8

Specifying air quality (purity) in accordance with ISO8573-1:2010, the international standard for Compressed Air Quality

ISO8573-1 is the primary document used from the ISO8573 series as it is this document which specifies the amount of contamination allowed in each cubic metre of compressed air.

ISO8573-1 lists the main contaminants as Solid Particulate, Water and Oil. The purity levels for each contaminant are shown separately in tabular form, however for ease of use, this document combines all three contaminants into one easy to use table.

ISO8573-1:2010 CLASS	Solid Particulate				Water		Oil
	Maximum number of particles per m ³			Mass Concentration mg/m ³	Vapour Pressure Dewpoint	Liquid g/m ³	Total Oil (aerosol liquid and vapour) mg/m ³
	0,1 - 0,5 micron	0,5 - 1 micron	1 - 5 micron				
0	As specified by the equipment user or supplier and more stringent than Class 1						
1	≤ 20 000	≤ 400	≤ 10	-	≤ -70 °C	-	0,01
2	≤ 400 000	≤ 6 000	≤ 100	-	≤ -40 °C	-	0,1
3	-	≤ 90 000	≤ 1 000	-	≤ -20 °C	-	1
4	-	-	≤ 10 000	-	≤ +3 °C	-	5
5	-	-	≤ 100 000	-	≤ +7 °C	-	-
6	-	-	-	≤ 5	≤ +10 °C	-	-
7	-	-	-	5 - 10	-	≤ 0,5	-
8	-	-	-	-	-	0,5 - 5	-
9	-	-	-	-	-	5 - 10	-
X	-	-	-	> 10	-	> 10	> 10

Specifying air purity in accordance with ISO8573-1:2010

When specifying the purity of air required, the standard must always be referenced, followed by the purity class selected for each contaminant (a different purity class can be selected for each contamination if required).

An example of how to write an air quality specification is shown below:

ISO 8573-1:2010 Class 1.2.1

ISO 8573-1:2010 refers to the standard document and its revision, the three digits refer to the purity classifications selected for solid particulate, water and total oil. Selecting an air purity class of 1.2.1 would specify the following air quality when operating at the standard's reference conditions :

Class 1 - Particulate

In each cubic metre of compressed air, the particulate count should not exceed 20,000 particles in the 0.1 - 0.5 micron size range, 400 particles in the 0.5 - 1 micron size range and 10 particles in the 1 - 5 micron size range.

Class 2 - Water

A pressure dewpoint (PDP) of -40°C or better is required and no liquid water is allowed.

Class 1 - Oil

In each cubic metre of compressed air, not more than 0.01mg of oil is allowed. This is a total level for liquid oil, oil aerosol and oil vapour.

ISO8573-1:2010 Class zero

- **Class 0 does not mean zero contamination.**
- **Class 0 requires the user and the equipment manufacturer to agree contamination levels as part of a written specification.**
- **The agreed contamination levels for a Class 0 specification should be within the measurement capabilities of the test equipment and test methods shown in ISO8573 Pt 2 to Pt 9.**
- **The agreed Class 0 specification must be written on all documentation to be in accordance with the standard.**
- **Stating Class 0 without the agreed specification is meaningless and not in accordance with the standard.**
- **A number of compressor manufacturers claim that the delivered air from their oil-free compressors is in compliance with Class 0.**
- **If the compressor was tested in clean room conditions, the contamination detected at the outlet will be minimal. Should the same compressor now be installed in typical urban environment, the level of contamination will be dependent upon what is drawn into the compressor intake, rendering the Class 0 claim invalid.**
- **A compressor delivering air to Class 0 will still require purification equipment in both the compressor room and at the point of use for the Class 0 purity to be maintained at the application.**
- **Air for critical applications such as breathing, medical, food, etc typically only requires air quality to Class 2.2.1 or Class 2.1.1.**
- **Purification of air to meet a Class 0 specification is only cost effective if carried out at the point of use.**

Parker Worldwide

Europe, Middle East, Africa

AE – United Arab Emirates, Dubai

Tel: +971 4 8127100
parker.me@parker.com

AT – Austria, Wiener Neustadt

Tel: +43 (0)2622 23501-0
parker.austria@parker.com

AT – Eastern Europe, Wiener Neustadt

Tel: +43 (0)2622 23501 900
parker.easteurope@parker.com

AZ – Azerbaijan, Baku

Tel: +994 50 2233 458
parker.azerbaijan@parker.com

BE/LU – Belgium, Nivelles

Tel: +32 (0)67 280 900
parker.belgium@parker.com

BY – Belarus, Minsk

Tel: +375 17 209 9399
parker.belarus@parker.com

CH – Switzerland, Etoy

Tel: +41 (0)21 821 87 00
parker.switzerland@parker.com

CZ – Czech Republic, Klecany

Tel: +420 284 083 111
parker.czechrepublic@parker.com

DE – Germany, Kaarst

Tel: +49 (0)2131 4016 0
parker.germany@parker.com

DK – Denmark, Ballerup

Tel: +45 43 56 04 00
parker.denmark@parker.com

ES – Spain, Madrid

Tel: +34 902 330 001
parker.spain@parker.com

FI – Finland, Vantaa

Tel: +358 (0)20 753 2500
parker.finland@parker.com

FR – France, Contamine s/Arve

Tel: +33 (0)4 50 25 80 25
parker.france@parker.com

GR – Greece, Athens

Tel: +30 210 933 6450
parker.greece@parker.com

HU – Hungary, Budapest

Tel: +36 1 220 4155
parker.hungary@parker.com

IE – Ireland, Dublin

Tel: +353 (0)1 466 6370
parker.ireland@parker.com

IT – Italy, Corsico (MI)

Tel: +39 02 45 19 21
parker.italy@parker.com

KZ – Kazakhstan, Almaty

Tel: +7 7272 505 800
parker.easteurope@parker.com

NL – The Netherlands, Oldenzaal

Tel: +31 (0)541 585 000
parker.nl@parker.com

NO – Norway, Asker

Tel: +47 66 75 34 00
parker.norway@parker.com

PL – Poland, Warsaw

Tel: +48 (0)22 573 24 00
parker.poland@parker.com

PT – Portugal, Leca da Palmeira

Tel: +351 22 999 7360
parker.portugal@parker.com

RO – Romania, Bucharest

Tel: +40 21 252 1382
parker.romania@parker.com

RU – Russia, Moscow

Tel: +7 495 645-2156
parker.russia@parker.com

SE – Sweden, Spånga

Tel: +46 (0)8 59 79 50 00
parker.sweden@parker.com

SK – Slovakia, Banská Bystrica

Tel: +421 484 162 252
parker.slovakia@parker.com

SL – Slovenia, Novo Mesto

Tel: +386 7 337 6650
parker.slovenia@parker.com

TR – Turkey, Istanbul

Tel: +90 216 4997081
parker.turkey@parker.com

UA – Ukraine, Kiev

Tel: +380 44 494 2731
parker.ukraine@parker.com

UK – United Kingdom, Warwick

Tel: +44 (0)1926 317 878
parker.uk@parker.com

ZA – South Africa, Kempton Park

Tel: +27 (0)11 961 0700
parker.southafrica@parker.com

North America

CA – Canada, Milton, Ontario

Tel: +1 905 693 3000

US – USA, Cleveland

Tel: +1 216 896 3000

Asia Pacific

AU – Australia, Castle Hill

Tel: +61 (0)2-9634 7777

CN – China, Shanghai

Tel: +86 21 2899 5000

HK – Hong Kong

Tel: +852 2428 8008

IN – India, Mumbai

Tel: +91 22 6513 7081-85

JP – Japan, Tokyo

Tel: +81 (0)3 6408 3901

KR – South Korea, Seoul

Tel: +82 2 559 0400

MY – Malaysia, Shah Alam

Tel: +60 3 7849 0800

NZ – New Zealand, Mt Wellington

Tel: +64 9 574 1744

SG – Singapore

Tel: +65 6887 6300

TH – Thailand, Bangkok

Tel: +662 186 7000-99

TW – Taiwan, Taipei

Tel: +886 2 2298 8987

South America

AR – Argentina, Buenos Aires

Tel: +54 3327 44 4129

BR – Brazil, Sao Jose dos Campos

Tel: +55 800 727 5374

CL – Chile, Santiago

Tel: +56 2 623 1216

MX – Mexico, Apodaca

Tel: +52 81 8156 6000

European Product Information Centre

Free phone: 00 800 27 27 5374

(from AT, BE, CH, CZ, DE, DK, EE, ES, FI, FR, IE, IL, IS, IT, LU, MT, NL, NO, PL, PT, RU, SE, SK, UK, ZA)

Catalogue PDE2660TCUK - V3 - September 2013

© 2013 Parker Hannifin Corporation. All rights reserved.



Parker Hannifin Ltd.

Tachbrook Park Drive

Tachbrook Park,

Warwick, CV34 6TU

United Kingdom

Tel.: +44 (0) 1926 317 878

Fax: +44 (0) 1926 317 855

parker.uk@parker.com

www.parker.com

ARA®

PNEUMATIK

53-012 Wrocław tel. 71 364 72 82
ul. Wyscigowa 38 fax 71 364 72 83

www.arapneumatik.pl

